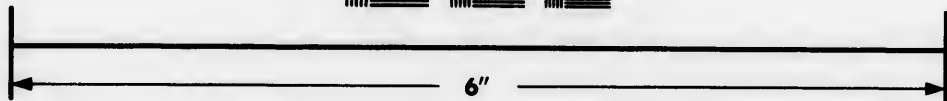
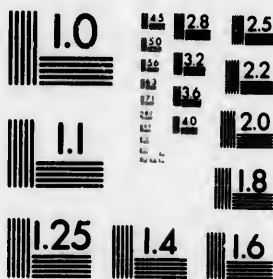

**IMAGE EVALUATION
TEST TARGET (MT-3)**



**Photographic
Sciences
Corporation**

23 WEST MAIN STREET
WEBSTER, N.Y. 14580
(716) 872-4503

**CIHM/ICMH
Microfiche
Series.**

**CIHM/ICMH
Collection de
microfiches.**



Canadian Institute for Historical Microreproductions / Institut canadien de microreproductions historiques

© 1981

Technical and Bibliographic Notes/Notes techniques et bibliographiques

The Institute has attempted to obtain the best original copy available for filming. Features of this copy which may be bibliographically unique, which may alter any of the images in the reproduction, or which may significantly change the usual method of filming, are checked below.

L'Institut a microfilmé le meilleur exemplaire qu'il lui a été possible de se procurer. Les détails de cet exemplaire qui sont peut-être uniques du point de vue bibliographique, qui peuvent modifier une image reproduite, ou qui peuvent exiger une modification dans la méthode normale de filmage sont indiqués ci-dessous.

- Coloured covers/
Couverture de couleur
- Covers damaged/
Couverture endommagée
- Covers restored and/or laminated/
Couverture restaurée et/ou pelliculée
- Cover title missing/
Le titre de couverture manque
- Coloured maps/
Cartes géographiques en couleur
- Coloured ink (i.e. other than blue or black)/
Encre de couleur (i.e. autre que bleue ou noire)
- Coloured plates and/or illustrations/
Planches et/ou illustrations en couleur
- Bound with other material/
Relié avec d'autres documents
- Tight binding may cause shadows or distortion
along interior margin/
La reliure serrée peut causer de l'ombre ou de la
distortion le long de la marge intérieure
- Blank leaves added during restoration may
appear within the text. Whenever possible, these
have been omitted from filming/
Il se peut que certaines pages blanches ajoutées
lors d'une restauration apparaissent dans le texte,
mais, lorsque cela était possible, ces pages n'ont
pas été filmées.
- Additional comments:/
Commentaires supplémentaires:

- Coloured pages/
Pages de couleur
- Pages damaged/
Pages endommagées
- Pages restored and/or laminated/
Pages restaurées et/ou pelliculées
- Pages discoloured, stained or foxed/
Pages décolorées, tachetées ou piquées
- Pages detached/
Pages détachées
- Showthrough/
Transparence
- Quality of print varies/
Qualité inégale de l'impression
- Includes supplementary material/
Comprend du matériel supplémentaire
- Only edition available/
Seule édition disponible
- Pages wholly or partially obscured by errata
slips, tissues, etc., have been refilmed to
ensure the best possible image/
Les pages totalement ou partiellement
obscurcies par un feuillet d'errata, une pelure,
etc., ont été filmées à nouveau de façon à
obtenir la meilleure image possible.

This item is filmed at the reduction ratio checked below/
Ce document est filmé au taux de réduction indiqué ci-dessous.

10X	12X	14X	16X	18X	20X	22X	24X	26X	28X	30X	32X
<input type="checkbox"/>	<input type="checkbox"/>	<input type="checkbox"/>	<input type="checkbox"/>	<input type="checkbox"/>	<input type="checkbox"/>	<input type="checkbox"/>	<input checked="" type="checkbox"/>	<input type="checkbox"/>	<input type="checkbox"/>	<input type="checkbox"/>	<input type="checkbox"/>

The copy filmed here has been reproduced thanks to the generosity of:

National Library of Canada

The images appearing here are the best quality possible considering the condition and legibility of the original copy and in keeping with the filming contract specifications.

Original copies in printed paper covers are filmed beginning with the front cover and ending on the last page with a printed or illustrated impression, or the back cover when appropriate. All other original copies are filmed beginning on the first page with a printed or illustrated impression, and ending on the last page with a printed or illustrated impression.

The last recorded frame on each microfiche shall contain the symbol \rightarrow (meaning "CONTINUED"), or the symbol ∇ (meaning "END"), whichever applies.

Maps, plates, charts, etc., may be filmed at different reduction ratios. Those too large to be entirely included in one exposure are filmed beginning in the upper left hand corner, left to right and top to bottom, as many frames as required. The following diagrams illustrate the method:

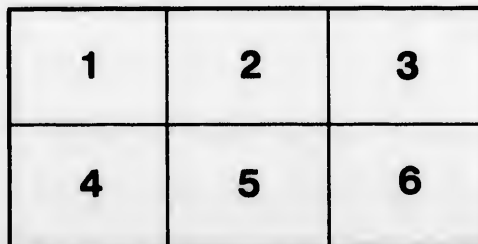
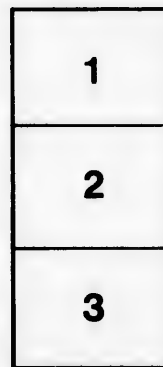

L'exemplaire filmé fut reproduit grâce à la générosité de:

Bibliothèque nationale du Canada

Les images suivantes ont été reproduites avec le plus grand soin, compte tenu de la condition et de la netteté de l'exemplaire filmé, et en conformité avec les conditions du contrat de filmage.

Les exemplaires originaux dont la couverture en papier est imprimée sont filmés en commençant par le premier plat et en terminant soit par la dernière page qui comporte une empreinte d'impression ou d'illustration, soit par le second plat, selon le cas. Tous les autres exemplaires originaux sont filmés en commençant par la première page qui comporte une empreinte d'impression ou d'illustration et en terminant par la dernière page qui comporte une telle empreinte.

Un des symboles suivants apparaîtra sur la dernière image de chaque microfiche, selon le cas: le symbole \rightarrow signifie "A SUIVRE", le symbole ∇ signifie "FIN".

Les cartes, planches, tableaux, etc., peuvent être filmés à des taux de réduction différents. Lorsque le document est trop grand pour être reproduit en un seul cliché, il est filmé à partir de l'angle supérieur gauche, de gauche à droite, et de haut en bas, en prenant le nombre d'images nécessaire. Les diagrammes suivants illustrent la méthode.

errata
to

pelure,
n à



ARTHUR

R

ARTHUR B. LEE, PRESIDENT

A. BURDETT LEE, VICE-PRESIDENT

RICE LEWIS & SON

LIMITED



ILLUSTRATED CATALOGUE
— OF —
GENERAL HARDWARE
TORONTO
CANADA

75405

R52

1898

fol.

PRINTED BY THE MAIL JOB PRINTING COMPANY, LIMITED, 110 BAY STREET

TORONTO. CANADA



compact
Tools,

glad to
by usi

a cont

TORONTO

TO THE TRADE

WE take pleasure in presenting our new Catalogue of GENERAL
HARDWARE.

We have introduced a good deal of new illustrated matter in the most compact form possible of General Hardware, Builders' Hardware, Metals, Glass, Tools, Cutlery, Guns, Ammunition, Fishing Tackle, etc.

We have retained as far as possible standard lists.

As values are constantly fluctuating, we issue no discount sheet, but shall be glad to quote prices on application. Customers will oblige us, and insure accuracy by using our catalogue numbers in ordering.

Thanking our numerous friends for their patronage in the past, and soliciting a continuance of their favors.

RICE LEWIS & SON, LIMITED,



Arthur W. Lewis

President.

TORONTO, SEPTEMBER, 1898.

Acme Fr
Adjustab
Fire
Ph
Ser
Sto
Tap
Adjuster
WI
Adze- Eve
Eye
Ha
Adzes, C
Coc
Ra
Shi
Agate Be
Agricultu
Air Cock
Rif
Alaska I
Alarm D
Til
Allen's A
Alligator
Almond
Aluminu
Car
Always I
Amateur
American
Co
Ha
Tr
Ammun
Analytic
Anchors
Angle St
Va
Angular
Bo
Anneale
Antimou
Anti Rat
Anvil To
Anvils an
Bl
Apple Pa
Arbors, C
Architec
Armstro
Arkansa
Ca

INDEX

A	PAGE	A	PAGE	A	PAGE
Acme Fry Pans	792	Ash Cans	329	Axle Clips	406
Adjustable Drawing Knives	153	Sifters	329	Grease	405
Fire Backs	797	Assay Balances	733 to 735	Pulleys	400, 470
Plunger Blocks	79	Atwater's Pipe Wrench Jaws	33	Washers	405
Scraper Planes	183	Auger Bits	104 to 107		
Stove Pipe	790	Bits in Sets	104		
Tap Wrenches	15, 17	Bit Guides	109		
Adjusters, Casement	614	Handles	202		
Window Stop	598	Augers, Boring Machine	107		
Adze Eye Hammer Handles	258	Carpenters	100		
Eye Hammers	230 to 238	Fruit	743		
Handles	250	Hollow	108		
Adzes, Carpenters	222	Post Hole	1000		
Coopers	175	Pump	107		
Railroad	222	Ship	100		
Ship	222	Automatic Drills	52, 156A		
agate Balances	737, 738	Fish Reels	1090		
Agricultural Wrenches	35	Fire Door Flxtures	401		
Air Cocks	313	Screw Drivers	155 to 157		
Rifles	901	Avery's Scales	737, 738		
Alaska Ice Breakers	702	Awl and Tool Sets	158 to 162		
Alarm Door Bells	500	Hafts	201		
Tills	721	Handles	201		
Allen's Anvil and Vise	68	Awls, Belt	279		
Alligator Wrenches	31	Brad	158		
Almond Drill Chucks	82	Harness	158		
Aluminum	320	Ice	702		
Camping Outfits	795	Peg	158		
Always Ready Wrenches	31	Saddlers	158		
Amateur Vises	70	Scratch	150		
American Chains	708	Sewing	158		
Cow Chains	714	Shoemakers	158		
Halter Chains	710	Awning Hooks	507		
Trace Chains	712	Hinges	507		
Ammunition	905 to 900	Lines	372		
Analytical Balances	733	Pulleys	355, 356		
Anchors	307	Slide Rods	507		
Angle Steel	1081	Slides	507		
Valves	307	Axe Handles	258		
Angular Bit Stocks	50	Stones	97		
Boring Machines	57	Wedges	219		
Annealed Wire	332	Axes, Bench	223		
Antimony	324	Boys'	219		
Anti Rattlers	405	Broad	221		
Anvil Tools	240, 241	Chopping	215 to 219		
Anvils and Vises Combined	68, 69	Coopers'	175		
Blacksmith	78	Double Bitted	218		
Apple Parers	723	Fireman's	220		
Arbors, Chuck	84	Handled	219		
Architects' Rules	135	Hunters'	219		
Armstrong's Stocks and Dies	28	Ship	220		
Arkansas Oil Stones	97, 99	Single Bitted	215 to 219		
Carving Tool Sets	99	Stone	244		

A
B
C
D
E
F
G
H
I
J
K
L
M
N
O
P
Q
R
S
T
U
V
W
X
Y
Z

Index

B	PAGE	B	PAGE	B	PAGE
Bar Supplies	702 to 772	Beach Drill Chucks	82	Bench Planes, Wood	178
Tin	324	Bead Planes, Adjustable	183	Screws	71
Trammell Points	105	Wood	170	Shears	41
Barbed Blind Staples	458	Beams and Channels	1081	Stops	171
Fence Wire	385	Beams, Scale	720	Vises	63 to 71
Wire Nails	424	Bear Traps	1015	Benders, Tire	267
Barber's Clippers	083	Beaters, Carpet	750	Bends, Return	304, 305
Hones	100	Egg	705	Bent Trimmers	010
Shears	000	Bed Casters	617	Bevel and Try Squares	123
Strops	808 to 000	Beef Slicers	087	Bevels, Ship Carpenters	121
Barley Forks	1018	Shavers	740	Sliding T	121
Barn Door, Bolts	500	Beer Cocks	774 to 770	Universal	120
Catches	500	Beeswax	381	Bibb Cocks, Air	313
Hangers	402 to 404	Bell Centering Punches	84	Compression	312
Hasps and Latches	505, 500	Hangers Bits	163	Bicycle, Padlocks	530
Latches, Sliding	500	Levers	587, 588	Screwplates	7, 8
Latches, Thumb	503	Pulls	588 to 501	Taps	20
Rall	407	Push Buttons	580	Wrenches	31
Stay Rollers	407	Straps, Cow	503	Binding Mitts	1004
Barometers, Cottage	255	Bellows, Blacksmith	274	Bird Cage Hooks	650, 660
Barrel Bolts	508, 500	Hand	274	Springs	600
Churns	701	Moulders	274	Bird Cages	812, 813
Crozes	177	Parlour	274	Bit and Square Levels	126
Headers	177	Bells, Alarm Door	500	Braces	52 to 50
Howels	177	Call	505	Brace Reamers	5
Nails	423	Car	501	Brace, Taps and Dies	6
Staples	458	Church	502	Gauges	160
Barrows, Baggage	710	Cow	503	Guides	160
Wheel	1071 to 1073	Door	583 to 500	Holders	6
Bars, Claw	232	Farm	502	Snaps	702
Crow	232	Gong Door	501	Stock Drills	2
Flagging	232	Hand	504	Stocks, Angular	50
Ice	231	House or Carriage	500	Wrenches	160
Shutter	000	Lever Door	580	Bits, Auger—	
Tumping	232	New Departure	505	Fostner	165
Towel	078	Rotary, Door	583 to 585	Gilmore's	161
Baseball, Bats	1035	Sheep	503	In sets	161
Gloves	1030	Sleigh	000 to 003	Irwin's	164, 165, 167
Masks	1037	Snap Shank	001	Jennings' Pattern	161
Mitts	1030	Tea	505	Rockford	161
Toeplates	1030	Team	001	Russell Jennings'	161
Baseballs	1035	Trip, Gong	501	Bits, Bridle	705
Base Knobs	576	Belt, Awls	270	Car	165
Baseman's Mitts and Gloves	1030	Fasteners	283	Centre	163
Basket Fasteners	458	Hooks	282	Countersink	163
Baskets, Clothes	757	Lacing	277, 282	Dowell	167
Fish	1034	Punches	280	Drill	2
Foot	757	Rivets	283	Gimlet	163
Tool	264	Studs	282	Horse	705
Bass Flies	1022	Tools	270	Nose	163
Bastard Files	87 to 91	Belting, Chain	276	Reamer	171
Basting Spoons, Enamelled	785	Cotton	270	Screw Driver	171
Tinned	973	Leather	277	Shell	163
Wood	750	Rubber	277	Spoon	163
Bathroom, Scales	720	Belts, Cartridge	1011	Black Diamond Files	90
Towel Racks	078	Bench Anvils	78	Lead	739
Bats, Baseball	1035	Axe Handles	258	Powder	169
Cricket	1030	Axes	223	Blacking, Boot	739
Batting Gloves	1030	Plain Irons	154	Stove	739
Baxter S Wrenches	37	Planes, Adjustable	181, 184	Blacksmiths' Anvil Tools	240 to 242, 249

Index

PAGE	B	PAGE	B	PAGE	B	PAGE
178	Blacksmiths' Anvils	78	Blowers, Roots	1070	Bolts, Wrought, Flat	508
71	Bellows	274	Blue Chalk	374	Wrought, Flush	572
41	Blowers	273, 1070	Rock Pigeons	1012	Bone Grinding Mills	742
171	Blacksmiths' Bolt Cutters	200	Rock Traps	1012	Boning Knives	1035
63 to 71	Bolt Machines	21, 23	Blunt Files	80 to 91	Books, Fly	1022
267	Cold Chisels	210 to 242	Board Rules	138	of Patterns	117
304, 305	Dies	10	Straw, Tarred	381	Boom Bands	361
910	Drills	58, 59	Boards, Bread	810	Chains	230
123	Flatters	240	Knife	794	Boot Calks	228
124	Foot Vises	200	Stove	797	Spikes	1030
124	Forges	270, 273	Wash	700	Borax	102
120	Hammers	238 to 240	Bolt Fittings, Galvanized	357 to 397	Borers, Angular Bit Stock	50
313	Hardies	210	Hooks	301	Bung	170
312	Lever Pincers	208	Nails	425	Tap	170
550	Mandrels	200	Spikes	425	Boring Machine Augers	107
7, 8	Pincers	43	Bobs, Plumb	129	Boring Machines	50, 57
20	Punches	212	Body Loops	107	Bottle Caps	772
34	Screwplates	10	Protectors	1037, 1041	Holders	770
1061	Sedges	230, 240	Boller Rivets	403	Stoppers	773
050, 060	Stocks and Dies	10	Rivets, Weight of	1087	Bottling Cocks	775
090	Swage Blocks	200	Boiler Tubes	302	Bottom Bolts	500, 570
812, 813	Taps	18	Boilers, Wash	700	Bowie Knives	880, 800
126	Tongs	43	Boker's Pocket Knives	824 to 815	Bowls, Butter	758
52 to 56	Vises	63	Skates	1014 to 1018	Scotch	1038
5	Blades, Saw—		Razors	001 to 005	Wash	787
6	Bracket	107	Bolt Clippers	200	Wood	758
100	Butchers'	214	Dies	13	Box Chisels	204
100	Compass	211, 214	Ends	304	Corners	635
6	Hack	105	Machines	21 to 23	Handles	618, 619
702	Key Hole	214	Bolts, Barrel	507, 509	Irons	630
2	Nests of	211	Bottom	509	Locks	534, 535
50	Pruning	211	Brass Flush	572, 573	Nails	423
100	Scroll	107	Carriage	382	Openers	204
	Turning	214	Chain Door	571	Rivets	402
105	Wood	214	Clip King	407	Rod Nuts	411
101	Blank Butts	445 to 447	Cupboard	508	Scrapers	204
103	Cartridges	005, 003	Elevator	307	Swivels	1033
104, 105, 107	Blanket Holders	630	Extension, Flush	574	Boxes, Auger Bits in	104
104	Blankets, Horse	080	Eye	300	Bread	801
101	Blanks, Key	517 to 521	Flint Brass	008	Cuke	801
101	Blat Gates	272	Foot	500, 570	Cash	801
705	Blasting Fuse	1001	Galvanized Hasp	508	Deed	801
105	Machines	1000	Guard	305	Folding Nail	382
103	Powder	000	Indicator, W. C.	032	Mitre	102, 103
103	Supplies	1000, 1001	Lag	305	Twine	721
107	Blind Butts, Inside	435	Machine	303	Vise	63
2	Hinges	451	Machine, Weight of	1057	Boxing Gloves	1042
103	Staples	458	Mortise, Door	572	Boxwood Rules	133 to 137
705	Block Plane Irons	154	Mortise, Flush	572 to 574	Boys' Axe Handles	258
103	Planes	181	Nut Eye	300	Axes	219
171	Tin	324	Neck	548	Forks and Knives	052
171	Blocks, Deck Halyard	357	Planer	308	Skates	1014 to 1019
103	Gin	347	Plow	305	Brace Drills	2
103	Planer	70	Shaft	302	Taps	18
00	Pulley	343 to 346	Sink	307	Braces, Bit	52 to 50
700	Snatch	347, 348, 357	Sleigh Shoe	300	Bit, Angular	56
000	Swage	200	Spring	508, 500	Drill	52 to 56
700	Tackle	347 to 349, 350, 357	Stove	307	Ratchet	52 to 55
700	Blowers, Hand	274, 1070	Tire	300	Reed's Lightning	156
000, 240 to 242, 200	Portable	270 to 273	Tower	507	Rudder	300

B
C
D
E
F
G
H
I
J
K
L
M
N
O
P
Q
R
S
T
U
V
W
X
Y
Z

Index

B	PAGE	B	PAGE	B	PAGE
Bracket Saws	100 to 108	Bread Boards	810	Bucks, Saw	207
Saw Patterns	197	Bowls	768	Budding Knives	801
Shade Rollers	080	Boxes	801	Buffing Wheels	91
Brackets, Blanket	000	Graters	741	Buggy Clips	100
Bridle	000	Knives	031	Builders' Hardware	420 to 082
Flower Pot	038	Pans	702	Hardware, Finishes of	427
Hand Roll	030	Breach Chains	713	Building Paper	381
Saddle	000	Drills	51	Bull Nose Rabbit Planes	181
Shelf	037	Strap Snaps	703	Bull Rings	700
Towel Roller	030	Strap Slides	705	Snaps	700
Vestibule	080	Breech Loading Guns	070 to 080	Bullet Moulding Sets	1006
Braid Awl Handles	201	Brick, Air	1075	Bullet Moulds	1008
Awls	158	Fire	337	Bullion Scales	735
Awls and Tools	150 to 102	Hammers	257	Bumpers, Rubber	287
Brads, Wire	424	Headers	380	Spring	287
Brass Air Cocks	313	Trowels	250	Bung Borees	170
Blbh Cocks	312	Bridle Bits	705	Starters	170
Box Swivels	1033	Bright Iron Wire	332	Bunting	823
Butts	428 to 430	Wire Screw Eyes	053 to 025	Flags	823
Cabin Hooks	010	Wire Screw Hooks	050 to 052	Burners, Lantern	822
Cased Rods	325	Broad Axe Handles	258	Burnishing Chains	818
Chair Nails	070	Axes	221	Burs, Copper	283
Cocks	300	Brass Butts	431	Rivets and	283
Cup Hooks	048	Bronze Screws	417	Iron	283
Curtain Rings	080	Brooms, Hair	380	Bush Hammers	245
Escutcheon Pins	421	Stable	301	Scythes	1055
Faucets	775, 770	Steel Wire	330	Bushel Measures	758
Ferrules	212	Brushes, Copying	381	Bushings, Malleable	333
Flush Bolts	572	Counter	380	Roller	310
Gate Hooks	050	Dundy	301	Butchers' Cleavers	750
Gun Shells	007	Horse	301	Ice Tongs	703
Head Nails	070	Household	300	Knives	1032 to 035
Hinges	428 to 445	Kalsomine	387	Meat Choppers	747 to 710
Hooks and Eyes	610, 050	Lather	800, 807	Saw Blades	211
Jack Chain	700	Marking	380	Saws	212, 213
Kettles	807, 808	Moulders'	330	Scales	727 730
Oilers	310 to 322	Paint	383 to 385	Steels	045
Ornaments	033	Painters' Dusting	380	Butler's Stove Polish	790
Pole Ends	080	Sash	384	Butt Gauges	173
Racking Cocks	775	Scratch	381	Butter Bowels	758
Rods	325	Scrub	388	Churns	701
Roll	325	Senning	380	Knives	020
Screw Rings	648	Shaving	800, 807	Ladles	758
Safety Chain	700	Shoe	380	Moulds	750
Scale Weights	738, 730	Stencil	380	Prints	750
Screw Eyes	053 to 055	Stove	388	Scales	720
Screw Hooks	618 to 052	Varnish	381, 385	Spades, Tinned	030
Screw Rings	048	Wall Paint	385	Spades, Wood	750
Screws	417	Whitewash	387	Triers	027
Spelter	324	Window	380	Trowels	020
Sheet	325	Buck Saw Blades	214	Butterfield's Reamers	5
Shoe Rivets	422	Saw Frames	207	Screw Plates	11
Shot Shells	907	Saw Rods	207	Button Head Rivets	402
Tubing	325	Saws	200, 207	Hole Punches	817
Valves	307 to 300	Shot	000	Hole Scissors	010
Wire	333	Buckets, Dinner	780	Buttons, Commode	031
Wire Cloth	330	Galvanized	791	Door	008
Brazed, Tubing	325	Buckles, Harness	705	Plyers	11
Braziers' Gasoline	45 to 47	Turn, Iron	304	Stair	082
Brazing Spelter	324	Turn, Galvanized	357	Butts, Blank	445, 417

Index

PAGE	B	PAGE	C	PAGE	C	PAGE
207	Butts, Blind	435	Caps, Military	908	Casement Window Catches	614
801	Blind, Inside	435	Car Bells	505	Cases, Carvers in	913, 914
91	Brass	431	Bits	165	Cutlery	958 to 960
400	Cabinet	428	Pushers	719	Dessert Knives and Forks in	903, 904
420 to 482	Desk	431	Card Frames	624	Fish Carvers in	900
es of	Fast Joint	431	Cards, Curry	684	Fish Knives and Forks in	904, 905
427	Loose Pin	434	Horse	684	Pocket Knife	863
381	Narrow Wrought	434	Wool	684	Razor Cases	908
181	Parliament	430	Carputhlan Silver Trays	800	Table Knives and Forks in	958
706	Refrigerator	429, 430	Carpenters' Adze Handles	250	Cash Box Locks	533
1006	Shutter	431	Adzes	222	Boxes	801
1008	Spring	412 to 417	Auger Bits	164	Casing Nails	423
725	Table	435	Augers	160	Cast Iron Feed Boxes	608
287			Boring Machines	50, 57	Hay Racks	608
170			Chalk	374	Jack Screws	342
170	Cabin Door Hooks	610	Chalk Lines	372	Pipe	301
823	Cabinet Butts	428	Chisels	115 to 140	Pipe Fittings	305
823	Catches	610	Clamps	71	Sledges	230
822	Drawer Pulls	620 to 630	Clamp Screws	74	Stable Fittings	908, 909
818	Escutcheons	632	Drawing Knives	152	Stair Plates	1075
281	Files	50, 91	Levels	125 to 128	Washers	402
281	Flush Bolts	572	Mallets	263	Cast Steel	1081
215	Hinge Plates	433	Penells	375	Casters, Bed	617
1055	Keys	519	Pincers	43	Furniture	611 to 617
758	Locks	522 to 531	Rules	133 to 137	Glass Ball	603
531	Makers' Clamps	75	Slicks	110	Truck	615
310	Rasps	89 to 91	Squares	122	Casting Leaders, Gut	1028
751	Scraper Planes	185	Wrought Rim Locks	483	Catches, Casement Window	610, 611
763	Trimmlings	432, 433	Carpet Beaters	750	Cupboard	610 to 613
932 to 935	Cabinets, Cutlery	950, 960	Felt	381	Elbow	608
747 to 749	Cable Chain, Coil	308	Stretchers	750	French Window	611
211	Wire	332	Sweepers	756	Screen Door	502
212, 213	Cage, Hooks	900	Tacks	41E, 421	Show Case	533
727 730	Springs	900	Carriage Bolts	302	Refrigerator	600
915	Cages, Bird	812, 813	Jacks	690	Transom	613
790	Cake Boxes	801	Makers' Clamps	75	Cattle Conchs	688
173	Pans	783, 791	Makers' Drawing Knives	152	Knives	835, 850, 860
758	Caliper Rules	134, 137	Malleables	100 to 111	Leaders	700
761	Calipers	107 to 111	Rivets	402	Marking Scissors	623
926	Calc Punches, Boot	228	Rugs	680	Ties, Chain	712
758	Sets, Boot	228	Step Pads	408	Ties, Rope	604
750	Calks, Boot	228	Wrenches	611	Caulking Irons	350
750	Toe	414	Carriers, Water	787	Mallets	350
730	Calls, Duck	1012	Cars, Construction	283	Ceiling Hooks	656 to 658
926	Camping Outfits	795	Cartridge Belts	1011	Cement Rubber	102
926	Stoves	795	Cartridges, Blank	905, 906	Portland	340
730	Cin Openers	707	Centre Fire	905, 906	Centre, Bead Planes, Adjustable	183
927	Candle Sticks, Miners'	249	Rim Fire	905	Bead Planes, Wood	170
926	Candy Scales	733	Shot	907, 908	Bits	103
5	Cans, Ash	320	Carvers, Collings and Wallis'	940	Clips	400, 410
11	Oil	793	Game	938 to 942	Fire Cartridges	905, 906
402	Cast Hook Handles	228	In Cases	943, 944	Gauges	116
817	Hooks	227	Rodgers	937 to 940	Reamers	5
919	Cap Screws	300	Turner's	937, 940 to 944	Centering Punches	84
631	Caps, B.B.	905	Wostenholm's	938	Centres, Neck Yoke	410
908	Bottle	772	Carving Knives and Forks	937 to 942	Sash	605
11	Dynamite	900	Carving Knives and Forks in Cases	943, 944	Transom	616, 617
682	Gun	908	Carving Tools	140 to 151	Cerite Waterproof Sheeting	381
445, 447	Hunting	1012	Casement Sash Adjusters	614		

B
C
D
E
F
G
H
I
J
K
L
M
N
O
P
Q
R
S
T
U
V
W
X
Y
Z

Index

C	C	C			
PAGE	PAGE	PAGE			
Challeng Dishes.....	800	Chilled Shot.....	000	Cleaners, Knife.....	761
Chain Belting.....	270	Chimes, Saddle.....	002, 003	Pot.....	818
Burnishers.....	818	Shaft.....	001, 002	Sidewalk.....	1051
Cow Ties.....	713 to 715	Chimney Thimbles.....	707	Tube.....	103
Dog Collars.....	1045	Chimneys, Lump.....	822	Window.....	300
Door Fasteners.....	575	China Nails.....	070	Cleaning Brushes.....	1006
Links.....	308	Chippers, Ice.....	702	Rods, Gum.....	1001, 1003
Padlocks.....	540, 550	Chisel Gouges.....	149	Clenring Rings.....	1031
Pipe Wrenches.....	30	Handles.....	200	Cleats, Line.....	362
Chains, American.....	708	Chisels, Box.....	231	Cleavers, Butchers'.....	751
Bench Show.....	711	Carving.....	149 to 151	Clevis Links.....	410
Boom.....	230	Cold.....	201	Screws.....	220
Breast.....	713	Cold, Blacksmiths'.....	240	Clevises, End.....	410
Cable.....	308	Corner.....	148	Malleable.....	410
Coil.....	308	Firmer Socket.....	148	Climax Horse Pokes.....	007
Cow Tie.....	712	Firmer Tanged.....	145	Clinch Nails.....	123
Crane.....	308	Framing.....	148	Rings.....	388
Dog.....	710	Handled.....	145 to 148	Rivets.....	281
Dredge.....	308	Ice Chipping.....	702	Tongs.....	43
German Coil.....	700	Ice Harvesting.....	31	Clip Cock Eyes.....	701
Halter.....	710	Joiners'.....	117	King Bolts.....	407
Jack.....	700	Millwright.....	140	Yokes, Axle.....	406
Kennel.....	710	Turning.....	140	Clippers, Toilet.....	083
Key.....	1047	Paring.....	145 to 148	Bolt.....	200
Log.....	230	Chippendale Cases.....	088	Dehorn'ng.....	214
Lumber.....	230	Choppers, Butchers'.....	751	Horse.....	083, 081
Picture.....	081	Meat.....	745 to 749	Sheep Too.....	1000
Post.....	712	Chopping Axes.....	215 to 219	Clipping Shears.....	208
Safety.....	700	Bowls.....	758	Clips and Rings.....	409
Sash.....	371	Knives.....	745, 031	Axle.....	406
Steel Wire.....	707	Trays.....	758	Buggy.....	406, 407
Trace.....	712	Chucks, Drill.....	80 to 81	Cutter.....	406
Transom.....	011	Chucking Runners.....	3	Hame.....	705
Chair Nails.....	070	Church Bells.....	502	Paper.....	720
Chalk, Carpenters'.....	371	Churns.....	700, 701	Singletree.....	400, 410
Crayon.....	371	Cider Press Screws.....	77	Spring Bar.....	406
Lines.....	372	Cigar Knives.....	929	Clocks, Control.....	1078
Lump.....	374	Circular Planes.....	183	Closers, Shell.....	1005
Chambers, Enamelled.....	787	Saws.....	200	Closet Indicator Bolts.....	432
Chamois Skins.....	818	Shears.....	44	Cloth, Emery.....	103
Champering Knives.....	175	Snips.....	44	Wire, Hardware.....	330
Champagne Nippers.....	707	Cistern Pumps.....	202, 203	Wire Screen.....	331
Taps.....	773	Clamp Heads.....	71	Wire Strainer.....	330
Champion Seales.....	726	Screws.....	75 to 77	Clothes Bars.....	078
Horse Pokes.....	007	Clamps, Carpenters'.....	71	Baskets.....	757
Chandelier Hooks.....	050 to 058	Cabinet Makers'.....	71 to 70	Line Cleats.....	362
Chasers.....	20	Carriage Makers'.....	75, 76	Line Hooks.....	061
Check Loops.....	411	Door.....	71	Line Pulleys.....	351
Valves.....	300	Game Trap.....	70	Lines.....	370
Checks, Door.....	1077	Hose.....	288	Pins.....	757
Cheese Press Screws.....	77	Lathe Dog.....	70	Reel Irons.....	1070
Scoops.....	1000	Quill Frame.....	77	Washing Machines.....	751
Triers.....	027	Ciew Bars.....	232	Wringers.....	752, 753
Cherry Stoners.....	743	Hatchets.....	221	Clothing, Hunters'.....	1011
Chest Handles.....	010	Claws, Nail.....	201	Glout Nail.....	420
Keys.....	510	Tack.....	231	Club Skates.....	1014 to 1019
Locks.....	532 to 535	Clay, Fire.....	337	Clubs, Golf.....	1028
Chests, Tool.....	100, 101	Cleaners, Drain.....	1007	Indian.....	1040
Children's Knives and Forks.....	051, 002	File.....	80	Conch Screws.....	305
Sets Plated.....	002	Gun.....	1003	Conchmakers' Drawing Knives.....	152

Index

PAGE	C	PAGE	C	PAGE	C	PAGE
761	Coachmakers' Vises.....	61, 65	Compression Hose Bibs.....	312	Corn Hooks.....	1058
818	Coal Barrows.....	1073	Gauge Cocks.....	312	Huskars.....	1063, 1061
1051	Hods.....	704	Water Gauges.....	315	Knives.....	1058
103	Pick Handles.....	259	Conductors' Lanterns.....	819	Planters.....	1063
389	Shovels.....	798	Punches.....	281	Poppers.....	765
1006	Sieves.....	328	Cone Head Rivets.....	402	Razors.....	901
1001, 1006	Scoops.....	1008, 1009	Confectioners' Scales.....	733, 739	Corner Chisels, Socket.....	118
1031	Coat and Hat Hooks.....	606 to 677	Cook Stoves.....	705	Feed Boxes.....	698
362	Coats, Hunting.....	1011	Cookers, Rice, Enamelled.....	781	Hay Racks.....	698
751	Cobblers Economy.....	717	Cooks' Forks.....	636	Irons.....	636
410	Cock Eyes.....	704	Knives.....	635, 693	Trowels.....	1001
229	Stop Boxes.....	312	Coolers, Water.....	810	Corrugated Brass Hinges.....	420
410	Cocks, Air.....	313	Coopers' Adzes.....	175	Steel Hinges.....	453
110	Beer.....	770	Axes.....	175	Sheet Iron.....	327
697	Bibb, Compression.....	312	Backing Shaves.....	175	Corundum Wheels.....	91
123	Bottling.....	775	Champering Knives.....	175	Cottage Barometers.....	255
308	Brass.....	309	Crozes.....	177	Thumb Latches.....	502
281	Gas.....	310, 311	Drivers.....	176	Cotters, Spring.....	404
31	Gauge.....	313	Dowel Machines.....	177	Cotton Bag Twine.....	372
701	Iron.....	309	Hammers.....	170	Bed Cords.....	370
497	Racking.....	775	Head Floats.....	177	Belting.....	276
409	Steam.....	309	Heading Shaves.....	175	Chalk Lines.....	372
683	Stop and Waste.....	312	Hollowing Shaves.....	175	Clothes Lines.....	370
269	Coffee Machines.....	898	Hoop Shaves.....	175	Duck.....	373
211	Mills.....	710 to 742	Howels.....	177	Hose.....	287
683, 681	Pots, Enamelled.....	781	Inshaves.....	176	Rope.....	370 to 372
1039	Pots, Tinned.....	798	Jointers.....	177	Sash Cord.....	371
268	Spoons.....	976, 978	Knives.....	175	Twine.....	372
409	Coil Chain.....	707 to 709	Levelers.....	177	Waste.....	286
106	Springs.....	335	Nails.....	421	Counter Brushes.....	389
306, 107	Coke Barrows.....	1073	Raising Irons.....	176	Scales.....	727 to 738
406	Cold Chisels.....	201	Rivets.....	403	Counters, Registering.....	139
765	Chisels, Blacksmiths'.....	210	Scrapers.....	170	Countersink Bits.....	163
729	Collar Washers.....	405	Spoke Shaves.....	170	Drills.....	5
409, 110	Collars, Dog.....	1014, 1015	Tools.....	175 to 177	Rivets.....	402
106	Stove Pipe.....	799	Truss Hoops.....	177	Countersinks.....	5, 170, 171
1078	Collapsible Drinking Cups.....	811	Vises.....	176	Couplers, Dog.....	711
1065	Combination Gauges.....	173, 171	Copper, Bar.....	324	Couplings, Hose.....	288
432	Glass Cutters.....	378	Boat Nails.....	420	Malleable Iron.....	301
41	Pipe Stocks.....	27	Hammers.....	239	Pump Rods.....	303
339	Pocket Knives.....	838 to 840,	Ingot.....	324	Shaft.....	323
331	850 to 853, 861, 880		Nail.....	420	Whiffletree.....	109
339	Planes.....	183, 184	Rivets and Burs.....	283	Covers, Dish.....	895
678	Pliers.....	37	Tacks.....	420	Gun.....	1010
757	Saws.....	298	Wire.....	333	Hatchet.....	1011
392	Try Squares and Bevels.....	124	Coppered Iron Rivets.....	283, 281	Rifle.....	1010
691	Vises.....	60, 68, 69	Iron Wire.....	332	Cow Bell Straps.....	593
351	Wrenches.....	32, 33	Steel Oilers.....	320 to 322	Bells.....	593
370	Combs, Cattle.....	688	Steel Spring Wire.....	332	Ties, Chain.....	713 to 715
757	Curry.....	685 to 688	Copperine.....	324	Ties, Rope.....	691
1070	Mane.....	681	Coppers, Soldering.....	48	Tie Out Chains.....	712
754	Commodore Buttons.....	631	Cord, Cotton.....	370 to 372	Cracks, Nut, Plated.....	970
752, 753	Comparative Lists—		Picture, Wire.....	681	Cradle Fingers.....	1053
1011	Cabinet Locks.....	539	Sash.....	371	Seythes.....	1055
420	Rules.....	133	Sash, Irons.....	601	Cradles, Grain.....	1073
1014 to 1019	Compass Pencil Holder.....	105	Cork Lined Faucets.....	771	Crane Chain.....	398
1028	Saw Blades.....	214	Floats.....	1033	Cranks, Grindstone.....	95
1040	Saws.....	211	Pullers.....	782	Crate Hasps.....	455
385	Compasses, Pencil.....	199	Screws.....	778 to 782	Crayons, Metal Workers'.....	374
Knives.....	Pocket.....	250, 251	Corks, Bottle.....	772	School.....	374

C
D
E
F
G
H
I
J
K
L
M
N
O
P
Q
R
S
T
U
V
W
X
Y
Z

Index

C	PAGE
Cricket Balls	1030
Butts	1030
Cross Cut Saw Handles	205
Cut Saws	202 to 205
Rim Wrenches	18
Crosses, Malleable	304
Cast Iron	305
Crow Bars	232
Crozes, Coopers'	177
Crucibles	340
Crumb Knives, Plated	672
Crown Ice Chippers	702
Cuffs, Hand	1046
Cullenders	788
Cultivator Steel	1081
Cup Hooks	048
Cupboard Bolts	610 to 613
Buttons	608
Catches	611, 612
Locks	530 to 532
Turns	613
Cups, Collapsible	811
Enamelled	783
Curling Irons	810
Curry Cards	684
Combs	685 to 688
Curtain Pins	618
Rings	680
Cushman Chucks	80 to 84
Cuspidors	793
Cut Lacing	277
Nails	423
Spikes	423
Tacks	418
Cutlery Cabinets	950, 000
Pocket	824 to 884
Table	037 to 000
Cutter Clips	400
Cutters, Band	1058
Expansive Bit	105
Feed Box	1003
Glass	379
Gummer	180
Lace	270
Meat	746, 747
Milling	4
Pipe	20
Plug	170
Slotting	4
Stone	245
Straw	1003
Thistle	1050
Tobacco	722
Vegetable	704
Wad	1002
Washer	270
Wire	37 to 42
Cutting Nippers	41, 42
Pliers	37 to 42
Cylinder Chest Locks	535

C	PAGE
Cylinder Cupboard Locks	531, 532
Drawer Locks	520, 527
Front Door Locks	498, 504
Lubricators	316, 317
Oil Pumps	316
Rim Night Latches	475 to 477
Wardrobe Locks	532
Cylinders, Pump	204
D	PAGE
D Fork Handles	1053
Shovel Handles	1053
Spade Handles	1053
Tops, Malleable	1053
Dado Planes, Adjustable	183, 184
Planes, Wood	179
Daggers	880, 800
Dairy Churns	700, 761
Pails	780
Pans	789
Thermometers	253 to 255
Dampers, Stove Pipe	707
Dandelion Spnds	1050
Dash Lamps	819
Dasher Churns	760
Daubers, Shoe	388
Dead Locks, Mortise	400
Rim Locks	483
Store Door Locks	408
Deck Blocks	357
Irons	364
Pipes	364
Decoy Ducks	1012
Deed Boxes	801
Deerlick Stones	97 to 100
Dehorning Clippers	214
Saws	213
Description of Finishes of Builders'	
Hardware	427
Desk Butts	431
Locks	529
Rulers	137
Dessert Forks	975 to 977
Knives	952 to 961
Knives and Forks	949 to 961, 963
Spoons	975 to 977
Detonators	900
Diamonds, Glaziers'	378
Die Guides	13
Dies and Taps	6 to 20
Blacksmiths'	6 to 16
Inserting	358
Pipe Thread	21 to 28
Stocks and, Blacksmiths'	7 to 16
Stocks and, Pipe	25 to 28
Dinner Pails	780
Plates	783
Dippers	787, 700
Dirk Knives	887 to 800

D	PAGE
Dirk Knives, Spring Back	887
Disks for China Nails	670
Jenkins'	307
Disgorgers	1031
Dish Covers	805
Pans	788
Dishes, Bacon	805
Baking	806
Chafing	806
Pudding	785
Soap	787
Ditching Scrapers	1071
Spades	1069
Dividers	100 to 110
Dog Chains	710, 711
Couplers	711
Collar Padlocks	541
Collars	1044, 1045
Leads	711
Muzzles	711
Whips	711
Dogs Lathe	79
Door Bells	583 to 586
Bolts	500 to 571
Buttons	608
Butts	428 to 447
Catches	610
Catches, Barn	566
Catches, Screen	652
Checks	1077
Clamps	71
Fasteners, Chain	575
Fixtures, Fire	461
Hangers, Barn	462 to 464
Hangers, House	465, 466
Holders	526, 1077
Hooks, Cabin	649
Keys	517 to 519
Knobs	511 to 511
Pulls	577 to 579
Push Plates	580
Rail, Barn	467
Rail, House	467, 468
Rollers, Barn	467
Sheaves	468
Springs	459
Stays, Barn	467
Stops	576, 1077
Door Latches—	
Barn	505, 506
Sliding	508, 509
Store	557 to 561
Thumb	563 to 565
Door Locks—	
Dead Mortise	400
Dead Rim	480 to 489
Mortise	400 to 510
Store, and Handles	557 to 559
Store, Mortise	490
Store, Rim	488

Index

PAGE
 k 887
 679
 307
 1031
 805
 788
 805
 806
 806
 785
 787
 1071
 1009
 100 to 110
 710, 711
 711
 544
 1014, 1045
 711
 711
 71
 583 to 586
 508 to 571
 608
 128 to 417
 010
 506
 652
 1077
 71
 575
 461
 402 to 464
 465, 466
 523, 1077
 619
 517 to 519
 511 to 511
 577 to 579
 580
 407
 467, 468
 407
 468
 450
 407
 576, 1077
 505, 506
 508, 509
 557 to 561
 503 to 505
 490
 486 to 489
 490 to 510
 557 to 559
 490
 488

D	PAGE
Doors, Hand of.....	420
Screen.....	331
Double Barrel Shot Guns.....	980 to 986
Bitted Axe Handles.....	258
Bitted Axes.....	218
Pointed Tacks.....	421
Dowel Bits.....	107
Forus.....	177
Machines.....	177
Drain Cleaners.....	1007
Spades.....	1007
Drum Flasks.....	811
Drawer Handles.....	625 to 630
Knobs.....	607, 632
Locks.....	522 to 528
Pulls.....	620 to 630
Drawers, Money.....	721
Drawing Knives.....	152, 153
Pins.....	679
Drawn Rods.....	1080
Dressers, Emery Wheel.....	86
Dried Beef Shavers.....	740
Drifting Pick Handles.....	250
Picks.....	247
Drill Braces.....	51 to 56
Chucks.....	82 to 84
Sockets.....	1
Drilling Machines.....	58, 59
Drills—	
Automatic.....	52, 156A
Bench.....	58, 59
Bit Stock.....	2
Blacksmith.....	58, 59
Breast.....	51
Hand.....	50 to 52
Straight Shank.....	1, 2
Taper Shank.....	1
Twist.....	1, 2
Drinking Cups.....	783, 811
Dripping Pans.....	792
Drive Well Points.....	205
Drivers, Coopers'.....	176
Drinking Fountains.....	300
Drivers, Screw.....	154 to 157
Drop Drawer Pulls.....	625 to 630
Handles.....	630
Druggit Pins.....	679
Dry Measures.....	758
Duck Calls.....	1012
Cotton.....	373
Ducks, Decoy.....	1012
Dudgeon's Tube Expanders.....	103
Dumb Waiter Fixtures.....	472
Walter Pulleys.....	471
Duplex Die Stocks.....	14, 27
Dust Pans.....	703
Dusters, Feather.....	300
Painters'.....	380
Dynamite.....	900
Caps.....	900

E	PAGE
Economy Cobblers.....	717
Edgers, Turf.....	1050
Elevator Bolts.....	397
Egg Beaters.....	705
Elbow Catches.....	608
Elbows, Cast Iron.....	305
Malleable Iron.....	304
Speaking Tube.....	802
Stove Pipe.....	793
Electric Blasting Supplies.....	1000, 1001
Push Buttons.....	580
Emery.....	92
Cloth.....	93
Grinders.....	95
Knife Sharpeners.....	100
Paper.....	93
Scythe Stones.....	100
Stones.....	98
Wheels.....	94
Wheel Dressers.....	86
Enamel, Stove.....	790
Enameline.....	790
Enamelled Graniteware.....	783 to 787
Signs.....	1077
End Clevises.....	229, 410
Ends, Bolt.....	394
Pole, Brass.....	680
Engineers' Fillers.....	322
Hammers.....	230
Oilers.....	319 to 322
Wrenches.....	36
Erasing Knives.....	803
Escutcheon Pins.....	421
Escutcheons, Cabinet.....	632
Door.....	515, 516
Evener Clevises.....	230
Eureka Saw Tools.....	188
Exercisers, Home.....	1043
Exhausters and Blowers.....	275
Expanders, Tube.....	103
Expansive Bits.....	165
Expert Traps.....	1012
Extension Flush Bolts.....	574
Extractors, Shell.....	1003
Extras, Iron.....	1080
Eye Shields.....	253
Eyes, Cock.....	724
Hooks and.....	650
Screw.....	653 to 655
Stair Rod.....	682

F	PAGE
Farm Bells.....	592
Farriers' Hammers.....	228
Knives.....	802
Pincers.....	43
Fasteners, Belt.....	283
Chain Door.....	575
Sash.....	500 to 601
Faucets, Brass.....	775, 770
Cork Lined.....	774
Petroleum.....	770
Self Measuring.....	777
Wood.....	774
Feather Dusters.....	390
Feed Boxes.....	758, 608
Pans.....	758
Felloe Plates.....	406
Webbs.....	214
Felt Buffing Wheels.....	91
Carpet.....	381
Turred.....	381
Fence Nails.....	123, 424
Staples.....	458
Wire.....	332, 335
Wire Stretchers.....	1070
Fencing Body Protectors.....	1041
Foil.....	1041
Gloves.....	1041
Masks.....	1041
Woven Wire.....	331
Ferrules and Hooks.....	230
and Rings.....	406
Brass.....	202
Fork.....	1053
Hoe.....	1053
Peavey Socket.....	228
Pike Pole.....	1053
Rake.....	1053
Rod.....	1043
Singletree.....	402
Field Hoes.....	1050
Figures, Steel.....	245
Stencil.....	245
File Cleaners.....	86
Handles.....	201
Files and Rasps.....	87 to 91
Nails.....	894
Paper.....	720
Stubs'.....	91
Swiss.....	91
Fillers, Engineers.....	322
Filester Planes—	
Adjustable.....	184
Wood.....	179
Filters.....	810
Fingers, Cradle.....	1053
Finishes, Builders Hardware.....	427
Finishing Nails.....	423, 421
Fire Backs, Stove.....	707
Brick.....	337
Clay.....	337

C
D
E
F
G
H
I
J
K
L
M
N
O
P
Q
R
S
T
U
V
W
X
Y
Z

Index

F	PAGE	F	PAGE	F	PAGE
Fire Door Fixture.....	404	Flue Stops.....	706	Fruit Augers.....	713
Door Hangers.....	404	Flash Bolts, Brass.....	572, 573	Gatherers.....	1000
Door Track.....	407	Cabinet.....	610	Knives.....	987
Shovels.....	708	Extension.....	574	Presses.....	742, 750
Fireman's Axes.....	220	Mortise.....	572	Fry Pans.....	783, 792
Firmer Chisel Handles.....	200	Flush Chest Handles.....	619	Fullers, Blacksmiths'.....	241
Chisels, Socket.....	148	Drawer Handles.....	625	Funnels.....	787
Chisels, Tanged.....	145	Rings, Brass.....	624	Furnace Scoops.....	1008
Firmer Gouges, Tanged.....	140	Sash, Lefts.....	603	Furnaces, Gasoline.....	15
Fish Baskets.....	1034	Trap Door Rings.....	619	Furnished Fish Lines.....	1028
Carvers.....	900	Fluted Reamers.....	3	Furniture Casters.....	611 to 617
Carvers in Cases.....	901	Fly Books.....	1022	Nails.....	679
Hooks.....	1020, 1021	Traps.....	705	Fuse, Safety.....	1001
Knives and Forks.....	904, 905	Fog Horns.....	359	Fuses, Electric.....	1001
Line Sinkers.....	1034	Foils, Fencing.....	1041		
Line Swivels.....	1033	Foot Balls.....	1040	G	
Lines.....	1028	Ball Shinguards.....	1040	Galvanized Ash Barrels.....	329
Fishing Poles.....	1031, 1032	Scrapers.....	1075	Boat Fittings.....	350 to 363
Reels.....	1029, 1030	Valves.....	308	Hasp Bolts.....	568
Rods.....	1031, 1032	Vises.....	209	Iron Pipe.....	392
Tackle.....	1020 to 1034	Folding Anchor.....	307	Pails.....	791
Fittings, Cast Iron.....	305, 306	Pocket Scissors.....	922	Pipe Fittings.....	301
Malleable.....	303, 304	Force Pumps.....	233	Poultry Netting.....	331
Pipe.....	300 to 315	Fore Plane Handles.....	250	Sheet Iron.....	327
Fixtures, Dumb Waiter.....	472	Planes, Adjustable.....	182	Wire.....	332
Fire Door.....	404	Planes, Wood.....	178, 182	Wire Clothes Lines.....	370
Grindstone.....	95	Forges, Portable.....	270 to 272	Wire Fencing.....	334
Stable.....	608, 609	Fork Bars, Ice.....	231	Wire Rope.....	300
Stall.....	714	Ferrules.....	1053	Game Bags.....	1011
Toilet.....	682	Handles.....	1053	Carvers.....	938 to 942
Flagging Bars.....	232	Pulleys, Hay.....	352	Trap Clamps.....	76
Flag Poles and Holders.....	823	Forks, Barley.....	1048	Traps.....	1013
Flags, Bunting, Etc.....	823	Boys'.....	1048	Garden Hoes.....	1050
Flange Unions.....	303	Cooks.....	936	Hooks.....	1062
Flaps, Shutter.....	431	Dessert.....	973 to 977	Hose.....	287
Flasks.....	811	Flesh.....	936	Lines.....	372
Flat Bar Iron.....	1080	Hay.....	1048	Rakes.....	1052
Bar Steel.....	1080	Manure.....	1048, 1049	Reels.....	1062
Head Rivets.....	402	Potato, Digging.....	1019	Rollers.....	1057
Head Screws.....	415 to 417	Salad.....	971	Sets.....	1051
Head Stove Bolts.....	307	Sardine.....	970	Shears.....	1059
Flatters, Blacksmiths'.....	240	Spading.....	1049	Trowels.....	1061
Flax Twine.....	372	Table.....	973 to 977	Wheelbarrows.....	1072
Fleams, Horse.....	892	Forins, Dowel.....	177	Gardner Governors.....	298, 299
Flesh Forks.....	936	Foundry Brushes.....	336	Garnet Paper.....	43
Flexible Speaking Tube.....	804	Facings.....	340	Gas Pipe.....	302
Flies, Trout and Bass.....	1022	Riddles.....	328	Pipe Fittings.....	303, 310, 311
Flint, Paper.....	93	Wire Cloth.....	330	Pipe Pliers.....	37, 38
Floats, Cork.....	1033	Fountains.....	300, 1062	Pipe Tonges.....	30
Flobert Rifles.....	987	Frames, Card.....	624	Pipe Wrenches.....	30 to 33
Floor Borders, Register.....	800	Hack Saw.....	194, 105	Gasoline Forges.....	45 to 47
Door Stops.....	570	Wood Saw.....	207	Gate Hinges.....	400, 401
Hooks.....	303	Framing Chisel Handle.....	200	Gate Hooks and Eyes.....	650
Planes.....	185	Chisels, Socket.....	148	Latches.....	450
Scrubbers.....	388	Freezers, Ice Cream.....	701	Valves.....	308
Flooring Nails.....	423, 424	French Cooks' Knives.....	633	Gates' Blast.....	272
Flour Sieves.....	328	Window Catches.....	610, 611	Molasses.....	77
Sifters.....	705	Window Locks.....	494	Oil.....	77
Flower Pot Brackets.....	638	Friction Drills.....	49	Gauge Tubes, Glass.....	315
Flue Scrapers.....	103	Front Door Locks.....	484, 498 to 507		

Index

PAGE
 713
 1000
 107
 742, 750
 783, 792
 211
 787
 1068
 45
 1028
 611 to 617
 679
 1001
 1001
 320
 356 to 363
 508
 302
 791
 304
 334
 791
 332
 332
 370
 334
 300
 1011
 938 to 942
 76
 1013
 1059
 1002
 287
 372
 1052
 1002
 1057
 1051
 1059
 1061
 1072
 298, 299
 93
 302
 303, 310, 311
 37, 38
 30
 30 to 33
 45 to 47
 490, 491
 659
 459
 308
 272
 777
 771
 315

G	PAGE
Gauges, Auger Bit	109
Butt	173
Caliper	118
Centre	116
Chisel	149
Depth	118
Jointer	193
Lumber	139
Marking	173, 174
Micrometer	117
Mortise	173, 174
Of Sheet Iron	1085
Pitch	116
Scratch	116
Surface	115
Thread	116
Timber	139
Wire	113
Gauging Rods	137
Trowels	256
Geese, Tailors'	755
German Coil Chain	700
Gimlet Bits	163
Halters	710
Screw Plates	15
Gimlet Bits	163
Gimlets	162
Girthing Tapes	110
Girths	689
Gimp Tacks	418
Glass Cutters	378
Window	379, 380
Glasses, Eye	253 and 1047
Field	252
Gauge	315
Level	128
Magnifying	250
Storm	255
Glaziers' Diamonds	378
Points, Zinc	420
Globe Valves	307
Globes, Lantern	822
Gloves, Baseball	1030
Boxing	1042
Cricket	1039
Fencing	1041
Husking	1063, 1064
Glue, Liquid	102
Marine	102
Pots	102
Sheet, etc.	102
Goggles	253
Gold Pans	248
Scales	249
Golf Balls	1038
Sticks	1038
Gongs, Alarm	500
Chimes	500
Engineers	501
Table	500

G	PAGE
Gongs, Trip	591
Gouges, Carving	149 to 151
Finer	146
Millwrights'	147
Paring	147
Turning	147
Grab Hooks	229
Grain Cradle Fingers	1053
Cradles	1053
Scoops	1068
Scythes	1055
Granite Ware	783 to 787
Grape Scissors	970
Seeders	743
Graphite	310
Grappling Irons	391
Grass Hooks	1055
Scythes	1055
Shears	1059
Graters, Nutmeg	744
Vegetable	744
Grates, Cesspools and	699
Gratings, Vault Light	1075
Gravy Ladles	972
Grease, Axle	405
Green River Screw Plates	8 to 11
River Dies	13
Grinders, Drill	95
Emerywheel	95
Grindstone Cranks	95
Fixtures	95, 96
Grindstones	96
Kitchen	96
Mounted	96
Weight of	96
Grommets and Washers	358
Grommet Rings	358
Groovers, Hand	185
Grooving Planes, Adjustable	184
Planes, Wood	178
Grub Hoes	246
Guides, Die	13, 14
Gunner Cutters	189
Gummers, Saw	189
Gun Caps	908
Cleaners	1003, 1004
Covers	1010
Implements	1003 to 1005
Lock	1002
Hammers	1002
Powder	999
Sights	1008, 1009
Wad Cutters	1002
Wads	1002
Worms	1002
Guns, Breech-Loading	970 to 986
Muzzle-Loading	970
Shot	970 to 886
Gut Leaders	1028
Gutters, Stable	699

H	PAGE
Hack Saw Blades	105
Saw Frames	104, 105
Hacking Knives	928
Hafts, Awl	291
Hair Clippers	883
Curling Irons	810
Wire	333
Halter Chains	710
Halters, Rings	701
Rope	694
Web	694
Ham Slicing Knives	937
Hame Clips	705
Staples	705
Hammer Handles	258
Hammerless Guns	982 to 986
Rifles	691
Hammers, Blacksmiths'	238
Brick	257
Coopers	176
Copper	239
Engineers'	239
Farriers'	238
Gun	1002
Hand, Blacksmiths'	238
Machinists'	239
Nail	230, 237
Napping	243
Riveting	235
Steak, Beef	745
Striking	243
Tack	234
Tinners'	235
Upholsterers'	235
Hammock Hooks	602, 603
Hammocks	1043
Hand Benders	185
Bellows	274
Bells	594
Blowers	1079
Cu.Ts	1046
Drills	52
Hammers, Blacksmiths'	238
Of Doors	426
Pumps	292, 293
Pinches	296
Rail Brackets	639
Rail Screws	610
Saw Handles	250
Saws	298 to 210
Screws	75
Shears, Tinners'	44
Taps	19
Vises	72, 73
Handled Axes	219
Brad Awls	158
Handles, Adze	250
Auger	292
Awl	291
Awl and Tool	291

F
G
H
I
J
K
L
M
N
O
P
Q
R
S
T
U
V
W
X
Y
Z

Index

H	PAGE	H	PAGE	H	PAGE
Handles, Axe	258	Hasp Bolts, Galvanized	508	Hoe Ferrules	1033
Bench Axe	258	Hasps and Staples	455, 450	Handles	1033
Boys' Axe	258	Basket	457	Hoes and Rakes, Weeding	1050
Brad Awl	201	Crate	455	Carrot	1050
Brass Lifting	625	Hinge	451 to 457	Field	1050
Brass Ring	624	Hooks and Staples	450	Garden	1050
Broad Axe	258	Hat and Coat Hooks	600 to 677	Grob	246
Cant Hook	228	Rack Hooks	675 to 677	Ladies'	1050
Chest	619	Hatchet Covers	1011	Mortar	1051
Chisel	200	Handles	258	Turnip	1050
Compass Saw	211	Hatchets, Bench	223	Weeding	1050
Cross Cut Saw	205	Claw	224	Hog Ringers	716
Double Bitted Axe	258	Hunters'	219	Rings	716
Drifting Pick	250	Lathing	225, 226	Tongs	716
Door	577 to 579	Shingling	224	Hoisting Tongs, Ice	703
Drawer	620 to 630	Hay Fork Handles	1053	Winches	315
File	201	Fork Pulleys	352	HOLDERS, Bit Brace	6
Flush Chest	619	Knives	1058	Blanket	680
Fork	1053	Rakes	1053	Door	1077
Hammer	258	Head Floats	177	Flag Pole	823
Hand Saw	250	Headers, Cast Iron	300	Glass	709
Hatchet	258	Heading Shaves	175	Pencil, Compass	105
Hoe	1053	Heads, Clamp	74	Hollow Augers	108
Malleable D	1053	Clothes Reel	1070	Hollowing Shaves	175
Mattock	250	Sprinkler	280, 290	Hollows and Rounds	170, 183
Panel Saw	250	Wheel	700	Home Cobblers	717
Peavey	228	Whitewash	387	Exercisers	1033
Pick	250	Heaters, Curling Iron	800, 816	Hones, Razor	100
Pit and Ice Saw	201	Hedge Shears	1050	Hoof Nippers	43
Plane	250	Heel Buttons, Skate	1019	Purrs	43
Rake	1053	Plates	1030	Hook and Eye Hinges	451
Sad Iron	755	Hemp Twine	372	And Strap Hinges	451
Saw	205, 250	Hexagon Nuts	400, 401	Hooks and Eyes	619, 650
Screw Driver	201	Hindustan Stones and Slips	97, 99	And Eyes, Tent	358
Shovel	1053	Hinge Hasps	454 to 457	And Staples	455, 456
Sledge	258	Hinges and Latches	450 to 461	Awning	507
Spade	1053	Blind, Inside	431	Belt	282
Store Door and Latch	559 to 561	Blind, Outside	431	Bird Cage	650, 699
Store Door and Lock	557, 558	Brass	428 to 431	Boat	300
Handy Trucks	718	Corrugated	420	Brass Cup	618
Hangers, Barn Door	462 to 464	Double Acting	414 to 446	Brass Screw	648, 651, 652
Fire Door	404	Gate	460, 461	Bright Screw	651, 652
Grindstone	95	Hook and Eye	454	Cabin Door	619
House Door	405, 406	Refrigerator	420, 430	Cant	227
Shafting	323	Saloon Door	447	Ceiling	600, 607
Hanks, Jib	301	Screen Door	442 to 447	Chain	229
Hardies	240	Screw Hook and	454	Chandelier	450 to 458
Hardware, Builders'	420 to 682	Shutter	431	Clothes Line	661
Builders' Finishes of	426	Spring	442 to 447	Coat and Hat	600 to 677
Wire Cloth	330	Strap	452 to 453	Corn	1058
Harness Awls	158	T	452, 453	Corner	619
Blacking	700	Table	435	Cup	618
Buckles	705	Trunk	433	Drapery	618
Hooks	671	Hitching Rings	701	Fish	1020, 1021
Menders	283	Posts	607	Floor	303
Rings	701	Weights	607	Garden	1002
Snaps	702, 703	Hockey Pucks	1019	Gas Pipes	658
Hartshorn Shade Rollers	689	Skates	1016 to 1019	Gate	456
Harvest Mitts	1004	Sticks	1019	Grab	228
Harvesting Tools	1048	Hods, Coal	704	Grass	1055

Index

	H	H	I	
PAGE	PAGE		PAGE	PAGE
1053	Hooks, Hammock.....082, 083	Hose, Suction.....287	Bench Screw.....75	
1053	Harness.....071	Washers.....280	Body Valves.....307, 308	
1050	Hasps and Staples.....455, 456	Hot Air Registers.....800	Corrugated.....327	
1050	Hay Fork.....383	House Pulleys.....353	Fittings, Pipe.....303 to 304	
1050	Laup.....050	Water Plates.....805	Galvanized.....327, 1085	
1050	Manure.....1049	Water Bacon Dishes.....805	Gas Pipe.....302	
216	Mat.....818	Hotel Trucks.....718	Gas Pipe Fittings, 303 to 304,	
1050	Meat.....064, 065	House Bells.....583 to 590	310, 311	
1051	Moulding.....081	Door Hangers.....465, 466	Gate Valves.....308	
1050	Paper File.....720	Door Track.....467	Gauges of.....1083	
1050	Picture.....081	Door Numbers.....583	Globe Valves.....307	
716	Potato.....1049	Howels, Coopers'.....177	Hoops.....1080, 1083	
716	S.....301, 064	Hungarian Nails.....422	Jack Chain.....700	
763	School House.....069	Hunters' Hatchets.....210	Levels.....125	
315	Screw.....051, 052	Hunting Caps.....1012	Machine Screws.....308	
6	Singletree.....230, 400	Coats.....1011	Malleables.....100 to 111	
089	Spoon.....1023 to 1027	Knives.....885 to 890	Norway.....1080	
1077	Tent and Eyes.....358	Pants.....1011	Notes on.....1080	
823	Tenter.....065	Vests.....1011	Planes.....181 to 185	
709	Trolling.....1023 to 1027	Husking Gloves.....1064	Rivets.....402, 403	
105	Wardrobe.....067	Mitts.....1064	Screws.....410	
168	Whiffletree.....230, 400	Pins.....1064	Sheet, Corrugated.....327	
175	Holsters, Revolver.....1011	Huskers, Corn.....1083, 1084	Sheet, Galvanized.....327	
170, 183	Hoop Iron.....1080	Hydraulic Jacks.....341	Sheet, Gauges of.....1085	
717	Iron Weight of.....1083	Rams.....201	Sheet, Planished.....327	
1043	Drivers.....170	Hydrants.....301	Sheet, Weight of.....1085	
100	Nails.....421		Snatch Blocks.....317, 318	
43	Shaves.....175		Squares.....122	
43	Hoops, Mast.....358	I	Tea.....1081	
451	Truss.....177	Ice Awls.....702	Swedes.....1080	
451	Horns, Fog.....359	Bars.....231	Weights of.....1083, 1084	
019, 050	Horse Bits.....705	Chisels.....231	Wire.....332	
358	Blankets.....089	Chippers.....702	Irons, Caulking.....350	
455, 456	Brushes.....301	Cream Freezers.....701	Clothes Reel.....1070	
507	Cards.....084	Forks.....231	Coopers' V.....176	
282	Clippers.....083, 084	Hooks.....231	Corner.....030	
050, 069	Clipping Shears.....923	Markers.....231	Curling.....810	
306	Fleams.....802	Picks.....702	Deck.....304	
048, 051, 052	Nails.....114	Ploughs.....231	Grappling.....306	
051, 052	Pokes.....067	Saws.....201	Malleable.....100 to 411	
019	Shoeing Hammers.....238	Scoops.....770	Neck Yoke.....410	
227	Shoeing Pinchers.....43	Shredders.....703	Pinking.....818	
000, 067	Shoes.....412, 413	Skates.....1014 to 1019	Plane.....154	
229	Singers.....081	Tongs.....703	Polishing.....755	
050 to 058	Tie Weights.....007	Ideal Reloading Tools.....1007	Raising.....176	
091	Tooth Rasps.....86	Implements, Gun.....1063 to 1065	Sad.....755	
000 to 077	Troughs.....300	Rifle.....1003 to 1008	Sash Cord.....001	
1058	Hose Bib Cocks.....312	Inclinometers.....110, 120	Singletree.....400	
619	Clamps.....288, 289	Indian Clubs.....1010	Soldering.....48	
618	Brewers'.....287	Indicator Bolts W.C.....432	Spoke Shave.....153	
618	Cotton.....287	Indicators, Speed.....104, 105	Tailors'.....755	
1020, 1021	Couplings.....288	Ingot Copper.....324	Troy Polishing.....755	
202	Garden.....287	Injectors.....200, 207	Tuyere.....208, 1070	
1062	Menders.....280	Inshaves, Coopers'.....170	Waving.....816	
638	Nozzles.....288	Inserting Dies.....358	Ivory Rules.....137	
456	Reels.....290	Insulating Tape.....1001		
228	Rubber.....287	Iron, Angle.....1081, 1083	J	
1055	Steam.....287	Band.....1080	Jack Chain.....700	
	Strap Pliers.....289	Bar.....1080	Screws.....341, 342	
	Straps.....280	Bar, Weight of.....1083, 1084		

I
J
K
L
M
N
O
P
Q
R
S
T
U
V
W
X
Y
Z

Index

J	PAGE
Jacks, Carriage.....	000
Waggon.....	000
Jail Padlocks.....	551
Jam Spoons.....	071
Jelly Cake Plates.....	791
Cake Pans.....	783
Cups.....	791
Moulds.....	791
Presses.....	750
Jigger's Liquor.....	770
"Jobs, Odd," Stanley's.....	128
Jointers, Coopers.....	177
Saw Tooth.....	188
Tucking.....	257

K	
Kalsomine Brushes.....	387
Kettles, Brass.....	808
Glue.....	102
Table.....	807, 808
Preserving.....	785
Windsor.....	786
Key Blanks.....	517 to 521
Chains.....	1047
Escutcheons, Cabinet.....	632
Escutcheons, Door.....	515, 516
Rings.....	1047
Key-Hole Saw Blades.....	211
Saw Pads.....	211
Saws.....	211
Keys.....	483, 517 to 521
King Bolts.....	407
Kitchen Grind Stones.....	96
Forks.....	936
Knives.....	930
Saws.....	213
Knife Boards.....	704
Cleaning Machines.....	704
Polish.....	92
Purses.....	803
Knitting Needles.....	885
Knives and Forks.....	910 to 952, 963, 964
Carving.....	937 to 944
Carving, in Cases.....	943, 944
Children's.....	951, 962
Dessert.....	901, 963, 964
Fish.....	965
Table.....	950 to 952
Knives, Adjustable Drawing.....	153
Band.....	1058
Bowie.....	880, 880
Bread.....	931
Butchers'.....	932 to 935
Butter.....	926
Butter, Plated.....	908, 909
Cattle.....	835, 819, 859, 869
Chaff.....	1003
Champering.....	175
Chopping.....	934

K	PAGE
Knives, Cigar.....	930
Coach Makers' Drawing.....	153
Cooks'.....	930
Coopers'.....	175
Corn.....	1058
Crumb.....	972
Dessert.....	910 to 961
Dirk, Spring Back.....	886, 887
Drawing.....	152, 153
Erasing.....	837, 833
Farriers'.....	872
Fish and Forks.....	964, 965
French Cooks'.....	936
Fruit, Plated.....	907
Hacking.....	928
Ham Slicing.....	937
Hay.....	1058
Hoop.....	175
Hunting.....	885 to 890
Kitchen.....	929, 930
Lemon.....	907
Mincing.....	745
Palette.....	929
Paper Hangers'.....	929
Pic, Plated.....	972
Pocket.....	824 to 884
Pork.....	935
Pruning.....	881
Putty.....	927, 928
Saw.....	213
Shackle.....	885
Shoe.....	929
Skinning.....	932 to 934
Slicing.....	937
Splitting.....	934
Spring Back.....	880, 887
Steak.....	935
Sticking.....	932 to 934
Table.....	940 to 961
Table, in Cases.....	958
Table, Plated.....	961
Knob Screws.....	515
Spindles.....	515
Knob Latches—	
French Window.....	494
Mortise.....	491, 492
Knob Locks—	
French Window.....	494
Front Door.....	498
Mortise.....	485, 494 to 507
Rim.....	478 to 485
Wrought Iron.....	483
Knobs, Drawer.....	607

L	
Lace Cutters, Leather.....	279
Cutters, Scissors.....	914 to 916
Lacing, Cut.....	277
Lacrosse Balls.....	1037

L	PAGE
Lacrosse Sticks.....	1037
Ladders, Step.....	769
Ladles, Butter.....	758
Cream.....	972
Gravy.....	972
Lead.....	48
Melting.....	48
Oyster.....	972
Soup.....	972
Lag Screws.....	395
Lamp Burners.....	822
Chimneys.....	822
Hooks.....	650
Wick.....	822
Lamps, Hand.....	249
Miners'.....	249
Landing Nets.....	1032
Lantern Burners.....	822
Globes.....	822
Wick.....	822
Lanterns, Conductors'.....	819
Police.....	820
Railroad.....	819
Tubular.....	819, 820
Lard Presses.....	750
Larding Pins.....	708
Lap Robes.....	689
Latches, Barn Door.....	565, 566
Cottage.....	562
French Window.....	491
Gate.....	459
Mortise Knob.....	491 to 493
Night, Mortise.....	493
Night, Rim.....	474 to 477
Refrigerator.....	609
Rim Knob.....	473
Sliding Barn Door.....	596
Sliding House Door.....	508, 509
Store Door and Handles.....	559 to 561
Thumb.....	563
Lath Hatchets.....	225, 226
Yarn.....	370
Lathe Tools.....	79
Lathes and Saws.....	196 to 199
Iron.....	85
Lasts, Shoe.....	717
Lava Tips.....	311
Lawn Edgers.....	1050
Mowers.....	1050, 1057
Rakes.....	1052
Rollers.....	1057
Seythes.....	1055
Sprinklers.....	289, 290
Vases.....	1062
Bowls.....	1038
Tennis Balls.....	1037
Tennis Markers.....	1038
Tennis Nets.....	1038
Tennis Poles.....	1038
Tennis Rackets.....	1037

Index

PAGE	L	PAGE
1037	Lead, Bar	324
700	Black.....	709
758	Ladles.....	48
072	Pencils.....	375 to 377
972	Pig.....	324
48	Pipe.....	325
48	Red and White.....	380
972	Sinkers.....	1034
972	Leaders, Cattle	706
395	Gut.....	1028
822	Leads, Dog	711
822	Leaning Knives	935
050	Leather Belting	277
822	Lace.....	277
249	Washers.....	405
249	Leg Guards	1030, 1040
1032	Leggings	1012
822	Lemon Knives	907
822	Squeezers.....	700
822	Letter Box Plates	581, 582
819	Scales.....	729
820	Letters, Metallic	205
819	Steel.....	205
810, 820	Level Glasses	128
750	Sights.....	120
708	Levelers, Coopers'	177
689	Levels, Bench	125 to 128
505, 506	Bit and Square.....	120
562	Carpenters'.....	120
491	Machinists'.....	125, 126
459	Plumb and.....	125 to 128
491 to 493	Pocket.....	125
493	Lever Cork Pullers	782
474 to 477	Door Bells.....	580
609	Jacks.....	312
473	Punches.....	200
506	Life Buoys and Jackets	373
508, 509	Lifters, Stove	798
559 to 561	Transom.....	615 to 617
563	Lifting Handles, Brass	625
225, 226	Jacks.....	341, 312
370	Lifts, Sash	602, 603
79	Lightning Braces	156
106 to 109	Taps and Dies.....	9 to 13
85	Screw Plates.....	7 to 12
717	Lignum Vitæ	1075
311	Line, Cleats	362
1050	Hooks, Clothes.....	601
1050, 1057	Pulleys, Clothes.....	351
1052	Reels, Clothes.....	1070
1057	Reels, Fish.....	1028
1055	Lines, Chalk	372
280, 290	Clothes.....	370
1062	Fish.....	1028
1038	Trolling.....	1028
1037	Wire Clothes.....	370
1038	Lining Nails	670
1038	Links, Clevis	229
1038	Repair.....	308
1037	Liquid Glue	102

L	PAGE
Liquid Measures	787, 793
Putz.....	92
Liquor, Jiggers	770
Pumps.....	777
Lists, Cabinet Lock	530
Loaded Paper Shells	907, 908
Loaders, Shell	1003
Lock Nuts, Malleable	301
Strikes.....	479, 483
Locks, Box	530
Cabinet.....	522 to 530
Cabinet, List of.....	530
Carpenter's Rim.....	483
Cash Box.....	533
Chest.....	532, 531, 535
Cupboard.....	530 to 532
Dead Rim.....	483, 480 to 480
Drawer.....	522 to 528
Front Door.....	408 to 500, 503 to 507
Gun.....	1002
Mortise, Knob 404 to 407, 501 to 503	
Oar.....	363
Pad.....	544 to 555
Post Office.....	530
Row.....	383
Sash and Lift.....	603
Sash.....	500 to 601
Ship, Brass.....	485
Sliding Door.....	510
Store Door.....	498, 557, 558
Store Door Rim.....	487 to 480
Trunk.....	537 to 542
Wardrobe.....	530 to 532
Log Chains	230
Rules.....	138
Loops, Check	411
Shaft and Body.....	407
Loose Pin Butts	434 to 441
Lubricators, Cylinder	316
Lumber Chains	230
Pencils.....	374
Lumbering Tools	227 to 230
Lump Chalk	374

M

Machine Augers	107
Bits.....	2, 107
Bolts.....	303
Bolts, Weight of.....	1087
Oilers.....	319 to 322
Screws, Iron.....	308
Screw Taps.....	18
Machinery Steel	1081
Machines, Blasting	1000
Bolt Cutting.....	21 to 23
Boring.....	57
Coffee.....	808
Dowel.....	177
Drill Grinding.....	95

M	PAGE
Machines, Drilling	58, 50
Knife Cleaning.....	704
Punching.....	200
Turning.....	85
Washing.....	754
Machinists' Drills	1, 2
Hammer Handles.....	258
Hammers.....	238
Levels.....	125
Magnets	1047
Magnifying Glasses	250
Magnetic Tack Hammers	234
Malleable Clevises	410
D Handles.....	1033
Gas Pipe Fittings.....	303, 304
Hooks and Eyes.....	649
Irons.....	400 to 411
Wrenches.....	411
Malleables, Carriage	400 to 411
Mallets, Carpenters'	202, 203
Carving.....	283
Caniking.....	350
Stone Cutters'.....	203
Tinnets'.....	203
Mandrels, Blacksmiths'	200
Mane Combs	681
Mangers	608
Mangles	754
Manicure Scissors	921, 922
Manilla Rope	370
Manure Fork Handles	1053
Forks.....	1049
Hooks.....	1049
Marline Spikes	350
Mariners' Compasses	250, 251
Glasses.....	252
Markers, Ice	231
Lawn Tennis.....	1038
Marking Awls	150
Brushes.....	380
Gauges.....	173, 174
Letters and Figures.....	205
Scissors, Cattle.....	923
Mashers, Potato	750
Masks, Baseball	1037
Fencing.....	1041
Masons' Hammers	244
Lines.....	372
Plumb Bobs.....	120
Plumbs and Levels.....	128
Stone Picks.....	245
Tools.....	245
Trowels.....	256
Mast Hoops	358
Mat Hooks	818
Masticators, Meat	745
Mathematical Sets	112
Mattock Handles	250
Mattocks	246
Mauls, Post	230

J
K
L
M
N
O
P
Q
R
S
T
U
V
W
X
Y
Z

Index

M	PAGE	M	PAGE	N	PAGE
Mauls, Railroad	243	Morse Twist Drills	1, 2	Nails, Hungarian	422
Ship	244	Mortars and Pestles	248	Lining	421, 679
Spike	243, 244	Mortar Hoes	1061	Number to the Pound	1087
Steak	745	Mortise Locks	485, 490 to 510	Picture	679
Measures, Dry	758	Door Knobs	511 to 514	Shingle	423
Enamelled	787	Gauges	173, 174	Shoe	422
Liquid	793	Knob Latches	491 to 493	Slating	424
Powder and Shot	1004	Night Latches	493	Trunk	420
Wood	758	Sash Locks	590	Upholsterers'	679
Measuring Faucets	777	Window Bolts	601	Wire	424
Tapes	140 to 144	Moulds, Bullet	1008	Napping Hammers	243
Meat Choppers	740 to 751	Moulding Sets, Bullet	1006	Narrow Brass Butts	431
Cutters	740 to 751	Moulders' Bellows	274	Wrought Butts	431
Hooks	604, 605	Brushes	336	Neck Yoke Irons	110
Juice Presses	742	Shovels	1008	Needles, Collar	365
Saws	212, 213	Tools	338, 339	Knitting	365
Stuffers	750	Moulding Hooks	681	Packing	365
Melting Ladles	48	Planes	178 to 180	Sail	365
Menders, Harness	283	Moulds, Butter	759	Upholsterers'	365
Hose	288, 289	Cake	792	Nest of Saws	211
Metal, Babbit	324	Jelly	791	Nets, Landing	1032
Polish	92	Mounted Grindstones	90	Tennis	1038
Slitting Saws	4	Oil Stones	97	Netting Poultry	331
Workers' Crayons	374	Mouse Traps	814, 815	Newmarket Horse Clippers	684
Metallic Letters and Figures	265	Mowers, Lawn	1056, 1057	Night Latches, Mortise	463
Metals	324	Muffin Pans	792	Latches, Rim	474 to 477
Micrometer Calipers	117	Music Wire	333	Nippers, Champagne	707
Military Cartridges	606	Muzzle Loading Guns	979	Cutting	41 to 43
Milk Boilers	784	Muzzles, Dog	711	Hoof	43
Pails	789			Nail	891
Strainers	788, 789			Police	1016
Millboard	280			Nipples, Wrought Pipe	363
Milling Cutters	4			Norway Iron	1080
Mills, Coffee	740 to 742			Nosing Planes	179
Paint	880			Notes on Iron and Steel	1086
Millwrights' Chisels and Gouges	146, 147			Nozzles, Hose	288
Mincing Knives	745			Numbers, House	583
Miners' Candle Sticks	249			Nut Augers	106
Fuse Capping Pliers	38			Cracks	970
Gold Pans	248			Picks	970
Gold Scales	249			Wrenches	18, 32 to 37, 411
Lamps	240			Nutmeg Graters	744
Magnifying Glasses	250			Nuts, Box Rod	411
Pick Handles	259			Hexagon	400, 401
Picks	247, 248			Square	400
Mining Hammers	243			Thumb	304, 411
Mirror Hinges	634			Waste	306
Supports	634				
Mitre Boxes	192, 193				
Rods	257				
Squares	119 to 124				
Mitts, Baseball	1036				
Binding	1064				
Harvest	1064				
Husking	1064				
Moits	951				
Molasses Gates	770, 777				
Money Drawers	721				
Mop Sticks	757				
Morse Screw Plates	15				

Index

	O		P																																																																																																																																																																																																																																																																																																																																																		
<table border="0" style="width: 100%;"> <tr><td style="text-align: right;">PAGE</td><td></td></tr> <tr><td style="text-align: right;">422</td><td>Oil Gates</td></tr> <tr><td style="text-align: right;">421, 679</td><td> Pumps</td></tr> <tr><td style="text-align: right;">1087</td><td> Slips</td></tr> <tr><td style="text-align: right;">679</td><td> Stones</td></tr> <tr><td style="text-align: right;">423</td><td> Stove Wicks</td></tr> <tr><td style="text-align: right;">422</td><td>Oilers, Brass</td></tr> <tr><td style="text-align: right;">421</td><td> Copperized Steel</td></tr> <tr><td style="text-align: right;">420</td><td> Engineers'</td></tr> <tr><td style="text-align: right;">679</td><td> In Sets</td></tr> <tr><td style="text-align: right;">421</td><td> Glass</td></tr> <tr><td style="text-align: right;">243</td><td> Mowing Machine</td></tr> <tr><td style="text-align: right;">431</td><td> Sight Feed</td></tr> <tr><td style="text-align: right;">434</td><td> Zinc</td></tr> <tr><td style="text-align: right;">410</td><td>Open Links</td></tr> <tr><td style="text-align: right;">365</td><td>Openers, Box</td></tr> <tr><td style="text-align: right;">365</td><td> Can</td></tr> <tr><td style="text-align: right;">365</td><td> Oyster</td></tr> <tr><td style="text-align: right;">365</td><td>Ornaments, Cast Brass</td></tr> <tr><td style="text-align: right;">211</td><td>Oval Slide Vises</td></tr> <tr><td style="text-align: right;">1082</td><td>Ox Balls</td></tr> <tr><td style="text-align: right;">1088</td><td>Oyster Ladles</td></tr> <tr><td style="text-align: right;">331</td><td> Knives</td></tr> <tr><td style="text-align: right;">681</td><td> Openers</td></tr> </table>	PAGE		422	Oil Gates	421, 679	Pumps	1087	Slips	679	Stones	423	Stove Wicks	422	Oilers, Brass	421	Copperized Steel	420	Engineers'	679	In Sets	421	Glass	243	Mowing Machine	431	Sight Feed	434	Zinc	410	Open Links	365	Openers, Box	365	Can	365	Oyster	365	Ornaments, Cast Brass	211	Oval Slide Vises	1082	Ox Balls	1088	Oyster Ladles	331	Knives	681	Openers	<table border="0" style="width: 100%;"> <tr><td style="text-align: right;">770, 777</td><td></td></tr> <tr><td style="text-align: right;">310, 777, 703</td><td></td></tr> <tr><td style="text-align: right;">98, 00</td><td></td></tr> <tr><td style="text-align: right;">97 to 00</td><td></td></tr> <tr><td style="text-align: right;">822</td><td></td></tr> <tr><td style="text-align: right;">310 to 322</td><td></td></tr> <tr><td style="text-align: right;">320 to 322</td><td></td></tr> <tr><td style="text-align: right;">320 to 322</td><td></td></tr> <tr><td style="text-align: right;">322</td><td></td></tr> <tr><td style="text-align: right;">317, 318</td><td></td></tr> <tr><td style="text-align: right;">310</td><td></td></tr> <tr><td style="text-align: right;">317</td><td></td></tr> <tr><td style="text-align: right;">310</td><td></td></tr> <tr><td style="text-align: right;">308</td><td></td></tr> <tr><td style="text-align: right;">204</td><td></td></tr> <tr><td style="text-align: right;">707</td><td></td></tr> <tr><td style="text-align: right;">708</td><td></td></tr> <tr><td style="text-align: right;">633</td><td></td></tr> <tr><td style="text-align: right;">68</td><td></td></tr> <tr><td style="text-align: right;">700</td><td></td></tr> <tr><td style="text-align: right;">972</td><td></td></tr> <tr><td style="text-align: right;">708</td><td></td></tr> <tr><td style="text-align: right;">708</td><td></td></tr> </table>	770, 777		310, 777, 703		98, 00		97 to 00		822		310 to 322		320 to 322		320 to 322		322		317, 318		310		317		310		308		204		707		708		633		68		700		972		708		708		<table border="0" style="width: 100%;"> <tr><td style="text-align: right;">PAGE</td><td></td></tr> <tr><td style="text-align: right;">783, 792</td><td>Pans, Roasting</td></tr> <tr><td style="text-align: right;">780</td><td> Sauce</td></tr> <tr><td style="text-align: right;">792</td><td> Stove</td></tr> <tr><td style="text-align: right;">381</td><td>Paper, Asbestos</td></tr> <tr><td style="text-align: right;">382</td><td> Bags</td></tr> <tr><td style="text-align: right;">381</td><td> Building</td></tr> <tr><td style="text-align: right;">381</td><td> Carpet</td></tr> <tr><td style="text-align: right;">720</td><td> Clips</td></tr> <tr><td style="text-align: right;">382</td><td> Cutters</td></tr> <tr><td style="text-align: right;">03</td><td> Emery</td></tr> <tr><td style="text-align: right;">720</td><td> Files</td></tr> <tr><td style="text-align: right;">03</td><td> Garnet</td></tr> <tr><td style="text-align: right;">929</td><td> Hangers' Knives</td></tr> <tr><td style="text-align: right;">382</td><td> Roll</td></tr> <tr><td style="text-align: right;">03</td><td> Sand</td></tr> <tr><td style="text-align: right;">900, 010</td><td> Shears</td></tr> <tr><td style="text-align: right;">107, 108</td><td> Shot Shells</td></tr> <tr><td style="text-align: right;">082</td><td> Toilet</td></tr> <tr><td style="text-align: right;">382</td><td> Wrapping</td></tr> <tr><td style="text-align: right;">319</td><td>Paragon Oilers</td></tr> <tr><td style="text-align: right;">723</td><td>Parers, Apple</td></tr> <tr><td style="text-align: right;">030</td><td>Paring Knives</td></tr> <tr><td style="text-align: right;">430</td><td>Parliament Butts</td></tr> <tr><td style="text-align: right;">271</td><td>Parlor Bellows</td></tr> <tr><td style="text-align: right;">405, 400</td><td> Door Hangers</td></tr> <tr><td style="text-align: right;">406, 407</td><td> Door Track</td></tr> <tr><td style="text-align: right;">02</td><td>Paste, Burnishine</td></tr> <tr><td style="text-align: right;">02</td><td> Putz</td></tr> <tr><td style="text-align: right;">1010</td><td>Parts of Spring Skates</td></tr> <tr><td style="text-align: right;">205</td><td>Pattern Letters and Figures</td></tr> <tr><td style="text-align: right;">228</td><td>Peavy Handles</td></tr> <tr><td style="text-align: right;">227</td><td>Peaveys</td></tr> <tr><td style="text-align: right;">201</td><td>Peg Awl Hafts</td></tr> <tr><td style="text-align: right;">158</td><td> Awls</td></tr> <tr><td style="text-align: right;">105, 100</td><td>Pencil Compasses</td></tr> <tr><td style="text-align: right;">105, 374</td><td> Holders</td></tr> <tr><td style="text-align: right;">375</td><td>Pencils, Carpenters'</td></tr> <tr><td style="text-align: right;">376, 377</td><td> Lead</td></tr> <tr><td style="text-align: right;">374</td><td> Lumber</td></tr> <tr><td style="text-align: right;">374</td><td> Metal Workers'</td></tr> <tr><td style="text-align: right;">008</td><td>Percussion Caps</td></tr> <tr><td style="text-align: right;">770</td><td>Perfection Faucets</td></tr> <tr><td style="text-align: right;">327</td><td>Perforated Zinc</td></tr> <tr><td style="text-align: right;">248</td><td>Pestles and Mortars</td></tr> <tr><td style="text-align: right;">770</td><td>Petroleum Oil Faucets</td></tr> <tr><td style="text-align: right;">641</td><td>Philadelphia Casters</td></tr> <tr><td style="text-align: right;">046</td><td>Piano Casters</td></tr> <tr><td style="text-align: right;">259</td><td>Pick Handles</td></tr> <tr><td style="text-align: right;">240</td><td> Mattocks</td></tr> <tr><td style="text-align: right;">247</td><td>Picks, Drifting</td></tr> <tr><td style="text-align: right;">702</td><td> Ice</td></tr> <tr><td style="text-align: right;">970</td><td> Nut</td></tr> <tr><td style="text-align: right;">248</td><td> Poll</td></tr> <tr><td style="text-align: right;">248</td><td> Prospectors'</td></tr> <tr><td style="text-align: right;">247</td><td> Railroad</td></tr> <tr><td style="text-align: right;">245</td><td> Stone</td></tr> <tr><td style="text-align: right;">681</td><td>Picture Chains</td></tr> <tr><td style="text-align: right;">681</td><td> Cord</td></tr> <tr><td style="text-align: right;">681</td><td> Hooks</td></tr> <tr><td style="text-align: right;">067</td><td> Knobs</td></tr> </table>	PAGE		783, 792	Pans, Roasting	780	Sauce	792	Stove	381	Paper, Asbestos	382	Bags	381	Building	381	Carpet	720	Clips	382	Cutters	03	Emery	720	Files	03	Garnet	929	Hangers' Knives	382	Roll	03	Sand	900, 010	Shears	107, 108	Shot Shells	082	Toilet	382	Wrapping	319	Paragon Oilers	723	Parers, Apple	030	Paring Knives	430	Parliament Butts	271	Parlor Bellows	405, 400	Door Hangers	406, 407	Door Track	02	Paste, Burnishine	02	Putz	1010	Parts of Spring Skates	205	Pattern Letters and Figures	228	Peavy Handles	227	Peaveys	201	Peg Awl Hafts	158	Awls	105, 100	Pencil Compasses	105, 374	Holders	375	Pencils, Carpenters'	376, 377	Lead	374	Lumber	374	Metal Workers'	008	Percussion Caps	770	Perfection Faucets	327	Perforated Zinc	248	Pestles and Mortars	770	Petroleum Oil Faucets	641	Philadelphia Casters	046	Piano Casters	259	Pick Handles	240	Mattocks	247	Picks, Drifting	702	Ice	970	Nut	248	Poll	248	Prospectors'	247	Railroad	245	Stone	681	Picture Chains	681	Cord	681	Hooks	067	Knobs	<table border="0" style="width: 100%;"> <tr><td style="text-align: right;">PAGE</td><td></td></tr> <tr><td style="text-align: right;">679</td><td>Picture Nails</td></tr> <tr><td style="text-align: right;">072</td><td>Pie Knives</td></tr> <tr><td style="text-align: right;">783, 791</td><td> Pintes</td></tr> <tr><td style="text-align: right;">324</td><td>Pig Lead</td></tr> <tr><td style="text-align: right;">710</td><td> Ringers</td></tr> <tr><td style="text-align: right;">710</td><td> Rings</td></tr> <tr><td style="text-align: right;">324</td><td> Tin</td></tr> <tr><td style="text-align: right;">43</td><td>Pincers, Blacksmiths'</td></tr> <tr><td style="text-align: right;">43</td><td> Carpenters'</td></tr> <tr><td style="text-align: right;">43</td><td> Farriers'</td></tr> <tr><td style="text-align: right;">43</td><td> Horse Shoe</td></tr> <tr><td style="text-align: right;">43</td><td> Shoemakers'</td></tr> <tr><td style="text-align: right;">381</td><td>Pine Tar</td></tr> <tr><td style="text-align: right;">227</td><td>Pike Poles</td></tr> <tr><td style="text-align: right;">818</td><td>Pinking Irons</td></tr> <tr><td style="text-align: right;">757</td><td>Pins, Clothes</td></tr> <tr><td style="text-align: right;">404</td><td> Cotter</td></tr> <tr><td style="text-align: right;">018</td><td> Curtain</td></tr> <tr><td style="text-align: right;">421</td><td> Escutcheon</td></tr> <tr><td style="text-align: right;">1000</td><td> Husking</td></tr> <tr><td style="text-align: right;">305</td><td> Knitting</td></tr> <tr><td style="text-align: right;">708</td><td> Larding</td></tr> <tr><td style="text-align: right;">750</td><td> Rolling</td></tr> <tr><td style="text-align: right;">121</td><td> Sash</td></tr> <tr><td style="text-align: right;">073</td><td> Towel</td></tr> <tr><td style="text-align: right;">301</td><td>Pipe, Cast Iron</td></tr> <tr><td style="text-align: right;">700</td><td> Collars</td></tr> <tr><td style="text-align: right;">29</td><td> Cutters</td></tr> <tr><td style="text-align: right;">707</td><td> Dampers, Stove</td></tr> <tr><td style="text-align: right;">25 to 28</td><td> Dies</td></tr> <tr><td style="text-align: right;">700</td><td> Elbows, Stove</td></tr> <tr><td style="text-align: right;">304, 305</td><td> Fittings</td></tr> <tr><td style="text-align: right;">302</td><td> Gas</td></tr> <tr><td style="text-align: right;">305</td><td> Hooks</td></tr> <tr><td style="text-align: right;">325</td><td> Lead</td></tr> <tr><td style="text-align: right;">37, 38</td><td> Pliers, Gas</td></tr> <tr><td style="text-align: right;">20</td><td> Reamers</td></tr> <tr><td style="text-align: right;">800</td><td> Registers</td></tr> <tr><td style="text-align: right;">25 to 28</td><td> Stocks and Dies</td></tr> <tr><td style="text-align: right;">700</td><td> Stove</td></tr> <tr><td style="text-align: right;">205</td><td> Strainers</td></tr> <tr><td style="text-align: right;">20</td><td> Taps</td></tr> <tr><td style="text-align: right;">707</td><td> Thimbles, Stove</td></tr> <tr><td style="text-align: right;">21 to 28</td><td> Threading Machines</td></tr> <tr><td style="text-align: right;">30</td><td> Tongs, Gas</td></tr> <tr><td style="text-align: right;">60, 61</td><td> Vises</td></tr> <tr><td style="text-align: right;">30 to 33</td><td> Wrenches, Gas</td></tr> <tr><td style="text-align: right;">302</td><td> Wrought Iron</td></tr> <tr><td style="text-align: right;">288</td><td>Pipes, Hose</td></tr> <tr><td style="text-align: right;">304</td><td> Chain Deck</td></tr> <tr><td style="text-align: right;">905</td><td>Pistol Cartridges</td></tr> <tr><td style="text-align: right;">1040</td><td>Pitching Shot</td></tr> <tr><td style="text-align: right;">292</td><td>Pitcher Spout Pumps</td></tr> <tr><td style="text-align: right;">787</td><td>Pitchers, Water</td></tr> <tr><td style="text-align: right;">201</td><td>Pit Saws</td></tr> <tr><td style="text-align: right;">250</td><td>Plane Handles</td></tr> <tr><td style="text-align: right;">154</td><td> Irons</td></tr> <tr><td style="text-align: right;">183</td><td>Planes, Adjustable Scraper</td></tr> <tr><td style="text-align: right;">181, 182</td><td> Bailey's</td></tr> <tr><td style="text-align: right;">170, 183</td><td> Beading</td></tr> </table>	PAGE		679	Picture Nails	072	Pie Knives	783, 791	Pintes	324	Pig Lead	710	Ringers	710	Rings	324	Tin	43	Pincers, Blacksmiths'	43	Carpenters'	43	Farriers'	43	Horse Shoe	43	Shoemakers'	381	Pine Tar	227	Pike Poles	818	Pinking Irons	757	Pins, Clothes	404	Cotter	018	Curtain	421	Escutcheon	1000	Husking	305	Knitting	708	Larding	750	Rolling	121	Sash	073	Towel	301	Pipe, Cast Iron	700	Collars	29	Cutters	707	Dampers, Stove	25 to 28	Dies	700	Elbows, Stove	304, 305	Fittings	302	Gas	305	Hooks	325	Lead	37, 38	Pliers, Gas	20	Reamers	800	Registers	25 to 28	Stocks and Dies	700	Stove	205	Strainers	20	Taps	707	Thimbles, Stove	21 to 28	Threading Machines	30	Tongs, Gas	60, 61	Vises	30 to 33	Wrenches, Gas	302	Wrought Iron	288	Pipes, Hose	304	Chain Deck	905	Pistol Cartridges	1040	Pitching Shot	292	Pitcher Spout Pumps	787	Pitchers, Water	201	Pit Saws	250	Plane Handles	154	Irons	183	Planes, Adjustable Scraper	181, 182	Bailey's	170, 183	Beading
PAGE																																																																																																																																																																																																																																																																																																																																																					
422	Oil Gates																																																																																																																																																																																																																																																																																																																																																				
421, 679	Pumps																																																																																																																																																																																																																																																																																																																																																				
1087	Slips																																																																																																																																																																																																																																																																																																																																																				
679	Stones																																																																																																																																																																																																																																																																																																																																																				
423	Stove Wicks																																																																																																																																																																																																																																																																																																																																																				
422	Oilers, Brass																																																																																																																																																																																																																																																																																																																																																				
421	Copperized Steel																																																																																																																																																																																																																																																																																																																																																				
420	Engineers'																																																																																																																																																																																																																																																																																																																																																				
679	In Sets																																																																																																																																																																																																																																																																																																																																																				
421	Glass																																																																																																																																																																																																																																																																																																																																																				
243	Mowing Machine																																																																																																																																																																																																																																																																																																																																																				
431	Sight Feed																																																																																																																																																																																																																																																																																																																																																				
434	Zinc																																																																																																																																																																																																																																																																																																																																																				
410	Open Links																																																																																																																																																																																																																																																																																																																																																				
365	Openers, Box																																																																																																																																																																																																																																																																																																																																																				
365	Can																																																																																																																																																																																																																																																																																																																																																				
365	Oyster																																																																																																																																																																																																																																																																																																																																																				
365	Ornaments, Cast Brass																																																																																																																																																																																																																																																																																																																																																				
211	Oval Slide Vises																																																																																																																																																																																																																																																																																																																																																				
1082	Ox Balls																																																																																																																																																																																																																																																																																																																																																				
1088	Oyster Ladles																																																																																																																																																																																																																																																																																																																																																				
331	Knives																																																																																																																																																																																																																																																																																																																																																				
681	Openers																																																																																																																																																																																																																																																																																																																																																				
770, 777																																																																																																																																																																																																																																																																																																																																																					
310, 777, 703																																																																																																																																																																																																																																																																																																																																																					
98, 00																																																																																																																																																																																																																																																																																																																																																					
97 to 00																																																																																																																																																																																																																																																																																																																																																					
822																																																																																																																																																																																																																																																																																																																																																					
310 to 322																																																																																																																																																																																																																																																																																																																																																					
320 to 322																																																																																																																																																																																																																																																																																																																																																					
320 to 322																																																																																																																																																																																																																																																																																																																																																					
322																																																																																																																																																																																																																																																																																																																																																					
317, 318																																																																																																																																																																																																																																																																																																																																																					
310																																																																																																																																																																																																																																																																																																																																																					
317																																																																																																																																																																																																																																																																																																																																																					
310																																																																																																																																																																																																																																																																																																																																																					
308																																																																																																																																																																																																																																																																																																																																																					
204																																																																																																																																																																																																																																																																																																																																																					
707																																																																																																																																																																																																																																																																																																																																																					
708																																																																																																																																																																																																																																																																																																																																																					
633																																																																																																																																																																																																																																																																																																																																																					
68																																																																																																																																																																																																																																																																																																																																																					
700																																																																																																																																																																																																																																																																																																																																																					
972																																																																																																																																																																																																																																																																																																																																																					
708																																																																																																																																																																																																																																																																																																																																																					
708																																																																																																																																																																																																																																																																																																																																																					
PAGE																																																																																																																																																																																																																																																																																																																																																					
783, 792	Pans, Roasting																																																																																																																																																																																																																																																																																																																																																				
780	Sauce																																																																																																																																																																																																																																																																																																																																																				
792	Stove																																																																																																																																																																																																																																																																																																																																																				
381	Paper, Asbestos																																																																																																																																																																																																																																																																																																																																																				
382	Bags																																																																																																																																																																																																																																																																																																																																																				
381	Building																																																																																																																																																																																																																																																																																																																																																				
381	Carpet																																																																																																																																																																																																																																																																																																																																																				
720	Clips																																																																																																																																																																																																																																																																																																																																																				
382	Cutters																																																																																																																																																																																																																																																																																																																																																				
03	Emery																																																																																																																																																																																																																																																																																																																																																				
720	Files																																																																																																																																																																																																																																																																																																																																																				
03	Garnet																																																																																																																																																																																																																																																																																																																																																				
929	Hangers' Knives																																																																																																																																																																																																																																																																																																																																																				
382	Roll																																																																																																																																																																																																																																																																																																																																																				
03	Sand																																																																																																																																																																																																																																																																																																																																																				
900, 010	Shears																																																																																																																																																																																																																																																																																																																																																				
107, 108	Shot Shells																																																																																																																																																																																																																																																																																																																																																				
082	Toilet																																																																																																																																																																																																																																																																																																																																																				
382	Wrapping																																																																																																																																																																																																																																																																																																																																																				
319	Paragon Oilers																																																																																																																																																																																																																																																																																																																																																				
723	Parers, Apple																																																																																																																																																																																																																																																																																																																																																				
030	Paring Knives																																																																																																																																																																																																																																																																																																																																																				
430	Parliament Butts																																																																																																																																																																																																																																																																																																																																																				
271	Parlor Bellows																																																																																																																																																																																																																																																																																																																																																				
405, 400	Door Hangers																																																																																																																																																																																																																																																																																																																																																				
406, 407	Door Track																																																																																																																																																																																																																																																																																																																																																				
02	Paste, Burnishine																																																																																																																																																																																																																																																																																																																																																				
02	Putz																																																																																																																																																																																																																																																																																																																																																				
1010	Parts of Spring Skates																																																																																																																																																																																																																																																																																																																																																				
205	Pattern Letters and Figures																																																																																																																																																																																																																																																																																																																																																				
228	Peavy Handles																																																																																																																																																																																																																																																																																																																																																				
227	Peaveys																																																																																																																																																																																																																																																																																																																																																				
201	Peg Awl Hafts																																																																																																																																																																																																																																																																																																																																																				
158	Awls																																																																																																																																																																																																																																																																																																																																																				
105, 100	Pencil Compasses																																																																																																																																																																																																																																																																																																																																																				
105, 374	Holders																																																																																																																																																																																																																																																																																																																																																				
375	Pencils, Carpenters'																																																																																																																																																																																																																																																																																																																																																				
376, 377	Lead																																																																																																																																																																																																																																																																																																																																																				
374	Lumber																																																																																																																																																																																																																																																																																																																																																				
374	Metal Workers'																																																																																																																																																																																																																																																																																																																																																				
008	Percussion Caps																																																																																																																																																																																																																																																																																																																																																				
770	Perfection Faucets																																																																																																																																																																																																																																																																																																																																																				
327	Perforated Zinc																																																																																																																																																																																																																																																																																																																																																				
248	Pestles and Mortars																																																																																																																																																																																																																																																																																																																																																				
770	Petroleum Oil Faucets																																																																																																																																																																																																																																																																																																																																																				
641	Philadelphia Casters																																																																																																																																																																																																																																																																																																																																																				
046	Piano Casters																																																																																																																																																																																																																																																																																																																																																				
259	Pick Handles																																																																																																																																																																																																																																																																																																																																																				
240	Mattocks																																																																																																																																																																																																																																																																																																																																																				
247	Picks, Drifting																																																																																																																																																																																																																																																																																																																																																				
702	Ice																																																																																																																																																																																																																																																																																																																																																				
970	Nut																																																																																																																																																																																																																																																																																																																																																				
248	Poll																																																																																																																																																																																																																																																																																																																																																				
248	Prospectors'																																																																																																																																																																																																																																																																																																																																																				
247	Railroad																																																																																																																																																																																																																																																																																																																																																				
245	Stone																																																																																																																																																																																																																																																																																																																																																				
681	Picture Chains																																																																																																																																																																																																																																																																																																																																																				
681	Cord																																																																																																																																																																																																																																																																																																																																																				
681	Hooks																																																																																																																																																																																																																																																																																																																																																				
067	Knobs																																																																																																																																																																																																																																																																																																																																																				
PAGE																																																																																																																																																																																																																																																																																																																																																					
679	Picture Nails																																																																																																																																																																																																																																																																																																																																																				
072	Pie Knives																																																																																																																																																																																																																																																																																																																																																				
783, 791	Pintes																																																																																																																																																																																																																																																																																																																																																				
324	Pig Lead																																																																																																																																																																																																																																																																																																																																																				
710	Ringers																																																																																																																																																																																																																																																																																																																																																				
710	Rings																																																																																																																																																																																																																																																																																																																																																				
324	Tin																																																																																																																																																																																																																																																																																																																																																				
43	Pincers, Blacksmiths'																																																																																																																																																																																																																																																																																																																																																				
43	Carpenters'																																																																																																																																																																																																																																																																																																																																																				
43	Farriers'																																																																																																																																																																																																																																																																																																																																																				
43	Horse Shoe																																																																																																																																																																																																																																																																																																																																																				
43	Shoemakers'																																																																																																																																																																																																																																																																																																																																																				
381	Pine Tar																																																																																																																																																																																																																																																																																																																																																				
227	Pike Poles																																																																																																																																																																																																																																																																																																																																																				
818	Pinking Irons																																																																																																																																																																																																																																																																																																																																																				
757	Pins, Clothes																																																																																																																																																																																																																																																																																																																																																				
404	Cotter																																																																																																																																																																																																																																																																																																																																																				
018	Curtain																																																																																																																																																																																																																																																																																																																																																				
421	Escutcheon																																																																																																																																																																																																																																																																																																																																																				
1000	Husking																																																																																																																																																																																																																																																																																																																																																				
305	Knitting																																																																																																																																																																																																																																																																																																																																																				
708	Larding																																																																																																																																																																																																																																																																																																																																																				
750	Rolling																																																																																																																																																																																																																																																																																																																																																				
121	Sash																																																																																																																																																																																																																																																																																																																																																				
073	Towel																																																																																																																																																																																																																																																																																																																																																				
301	Pipe, Cast Iron																																																																																																																																																																																																																																																																																																																																																				
700	Collars																																																																																																																																																																																																																																																																																																																																																				
29	Cutters																																																																																																																																																																																																																																																																																																																																																				
707	Dampers, Stove																																																																																																																																																																																																																																																																																																																																																				
25 to 28	Dies																																																																																																																																																																																																																																																																																																																																																				
700	Elbows, Stove																																																																																																																																																																																																																																																																																																																																																				
304, 305	Fittings																																																																																																																																																																																																																																																																																																																																																				
302	Gas																																																																																																																																																																																																																																																																																																																																																				
305	Hooks																																																																																																																																																																																																																																																																																																																																																				
325	Lead																																																																																																																																																																																																																																																																																																																																																				
37, 38	Pliers, Gas																																																																																																																																																																																																																																																																																																																																																				
20	Reamers																																																																																																																																																																																																																																																																																																																																																				
800	Registers																																																																																																																																																																																																																																																																																																																																																				
25 to 28	Stocks and Dies																																																																																																																																																																																																																																																																																																																																																				
700	Stove																																																																																																																																																																																																																																																																																																																																																				
205	Strainers																																																																																																																																																																																																																																																																																																																																																				
20	Taps																																																																																																																																																																																																																																																																																																																																																				
707	Thimbles, Stove																																																																																																																																																																																																																																																																																																																																																				
21 to 28	Threading Machines																																																																																																																																																																																																																																																																																																																																																				
30	Tongs, Gas																																																																																																																																																																																																																																																																																																																																																				
60, 61	Vises																																																																																																																																																																																																																																																																																																																																																				
30 to 33	Wrenches, Gas																																																																																																																																																																																																																																																																																																																																																				
302	Wrought Iron																																																																																																																																																																																																																																																																																																																																																				
288	Pipes, Hose																																																																																																																																																																																																																																																																																																																																																				
304	Chain Deck																																																																																																																																																																																																																																																																																																																																																				
905	Pistol Cartridges																																																																																																																																																																																																																																																																																																																																																				
1040	Pitching Shot																																																																																																																																																																																																																																																																																																																																																				
292	Pitcher Spout Pumps																																																																																																																																																																																																																																																																																																																																																				
787	Pitchers, Water																																																																																																																																																																																																																																																																																																																																																				
201	Pit Saws																																																																																																																																																																																																																																																																																																																																																				
250	Plane Handles																																																																																																																																																																																																																																																																																																																																																				
154	Irons																																																																																																																																																																																																																																																																																																																																																				
183	Planes, Adjustable Scraper																																																																																																																																																																																																																																																																																																																																																				
181, 182	Bailey's																																																																																																																																																																																																																																																																																																																																																				
170, 183	Beading																																																																																																																																																																																																																																																																																																																																																				

M
N
O
P
Q
R
S
T
U
V
W
X
Y
Z

Index

P	PAGE	P	PAGE	P	PAGE
Planes, Bench	178, 182	Pliers, Round Nose	30, 42	Pots, Glue	102
Block	181	Plow Bolts	305	Tea	781, 798
Bull Nose Rabbit	181	Planes	180, 183, 184	Potts' Sad Irons	755
Circular	183	Plows, Ice	211	Poultry Netting	331
Combination	183, 184	Plug Cutter	170	Netting Staples	458
Dado	183, 184	Taps	18, 19	Powder and Shot Measures	1001
Fillester	170, 181	Plugs, Malleable	303	Black	900
Floor	185	Plumb Bobs	120	Blasting	900
Hand Beader	185	Plumbago	340	Oakley's Plate	92
Hollows and Rounds	170, 183	Plumbers' Solder	324	Smokeless	909
Match	178	Plumbs and Levels	125 to 129	Preserving Kettles	785
Moulding	178 to 182	Plyers. See Pliers.		Presses, Fruit, etc	742, 759
Nosing	170	Pocket Compasses	250, 251	Meat Juice	742
Ogee	180	Cork Screws	778	Vegetable	701
Plow	180, 183, 184	Gold Seal	240	Prick Punches	172
Quarter Round	180	Knives	821 to 884	Primers	908
Rabbit	178, 181	Levels	125	Prints, Butter	750
Reedling	183	Telescopes	252	Protectors, Body	1030, 1041
Router	185	Measuring Tapes	140	Eye	744
Sash	180	Scissors	910, 917, 918	Prospectors' Picks	748
Scotch	178	Thermometers	253	Magnifying Glasses	250
Scotia	180	Wrenches	31	Protractors' Bevel	120
Scraper	183	Pointers, Spoke	100	Pruners, Tree	1059
Slitting	183	Pointing Trowels	250	Pruning Knives	801
Stanleys	181, 183	Points, Drive Well	295	Saw Blades	211
Table	180	Glaziers' Zine	420	Saws	211
Tonguing	184	Tailors'	010, 010	Shears	1000
Tooth	183	Trammel	105	Pucks, Hockey	1019
Veneer Scraper	183	Pokes, Horse	607	Pudding Pans	785, 790
Wood Bench	178	Pole Ends, Brass	080	Pullers, Nail	201
Planer Blocks	70	Poles, Fishing	1031, 1032	Pulley Taps	19
Planters, Corn	1063	Pike	227	Pulleys, Awning	355, 356
Planished Sheet Iron	327	Tennis Net	1038	Axle	100, 470
Plastering Trowels	257	Police Lanterns	820	Brass Screw	354
Plate, Castors	011, 044	Nippers	1040	Clothes Line	351
Plated Ware, Flat	007 to 078	Polish, Knife	92	Differential	315
Plates, Escutcheon, Cabinet	632	Metal	92	Dumb Waiter	471
Escutcheon Door	515, 516	Silver	92	Hay Fork	352
Felloe	406	Stove	709	Hot House	353
Heel	1030	Polishing Irons	755	Hyper-Acme	343
Hinge	033	Paste	92	Sash	400 to 471
Hook	305	Supplies	92	Screw	354
Hot Water	805	Poll Pick Handles	250	Side	353
Letter Box	581, 582	Picks	258	Split	278
Lettered, Enamelled	1077	Pomade, Putz	92	Tackle	355, 356
Pie	783, 791	Poppers, Corn	705	Upright	353
Push	580	Porcelain Head Nails	679	Pulls, Door	578, 579
Sash	005	Portable Blowers	270 to 273, 1079	Drawer	620 to 630
Screw	7 to 16	Forges	270 to 272	Sash	005
Stair	082, 1075	Post Chains	712	Screen Door	578, 579
Toe	1030	Hole Augers	1000	Pump Augers	167
Transom	005	Hole Spades	1006	Cylinders	204
Wall	300	Hole Spoons	1067	Makers' Stocks and Dies	12
Whiffletree	400	Postal Scales	720	Roamers	107
Platform Scales	724 to 727	Posts, Hitching	607	Rod Couplings	303
Pliers, Combination	37	Pot Cleaners	818	Strainers	245
Cutting	39 to 42	Potato Hooks	1049	Tools	167
Flat Nose	39 to 42	Potato Mashers	750	Pumps, Cistern	202, 203
Gas	37, 38	Scoops	1050	Cylinder	316
Hose, Strap	280	Pots, Coffee	784, 798		

Index

PAGE	P	PAGE	R	PAGE	R	PAGE
102	Pumps, Force	201	Railroad Trucks	251, 718	Return Bends, Malleable	304
784, 798	Liquor or Oil	777	Raisin Seeders	743	Revolver Holsters	1011
755	Spray	200	Rake Ferrules	1053	Revolvers	992 to 1004
334	Punch and Shear Combined	208	Handles	1033	Revolving Clothes Reels	1070
458	Punches, Belt	200	Rakes and Hoes, Weeding	1050	Punches	290
1000	Blacksmiths'	242	Garden	1052	Ribbon Sash Cord	371
1000	Boot Calk	228	Hay	1051	Rifles, Veterinary	80
1000	Button Hole	817	Lawn	1052	Rice Boilers	784
92	Centre	172	Rans, Hydraulic	201	Riddles, Foundry	828
1000	Centring	81	Rasps, Cabinet	89 to 91	Wire	328
785	Conductors'	281	Horse	87, 90, 91	Rifle Cartridges	905, 906
742, 750	Lever, Hand	208	Horse Tooth	86	Covers	1010
742	Prick	172	Shoe	90, 91	Implements	1006 to 1008
761	Revolving	290	Wood	80 to 91	Sights	1008, 1009
172	Rivet	172	Rat Traps	814, 815	Rifles	989 to 990
908	Spring	280	Ratchet Braces	53 to 55	Air	901
759	Ticket	281	Drills	2, 40, 50	Rim Dead Locks	483, 480
1000, 1041	Punching Presses	200	Pipe Stocks	27	Door Locks	478 to 480
23	Purses, Pocket Knife	803	Screw Drivers	155 to 156	Fire Cartridges	605
78	Push Buttons	580	Rattlers, Anti	405	Knobs, Door	511 to 514
250	Plates	580	Razor Cases	908	Knob Latches	473
120	Pushers, Car	719	Hones	100	Knob Locks	478 to 484
1050	Putty	380	Strops	808 to 900	Night Latches	474 to 477
891	Knives	927, 928	Strapping Machines	900	Store Locks	487 to 480
211	Putz, Liquid	92	Razors	901 to 908	Ring Drawer Pulls	630
211	Pomade	92	Corn	901	Ringers, Hog	716
1000			Safety	901	Rings and Staples	701
1019			Reamers, Brace	5, 171	Brass, Screw	648
785, 790			Pipe	20	Bull	700
261	Q		Shell	4	Clearing	1034
19	Quartz	92	Solid	3	Clineh	425
355, 350	Quicksilver	240	Recappers	1068	Curtain	680
100, 470	Quilt Frame Clamps	76, 77	Red Chalk	374	Flush, Brass	624
351	Quilts	1040	Lead	380	Grommets	358
351			Reducers, Malleable	304	Halter	701
345	R		Reducing Elbows	304, 305	Harness	701
471	Rabbit Planes	178, 181, 183	Tees	304, 305	Hitching	700, 701
344	Rack Hooks, Hat	675 to 677	Reeling Planes	183	Hog and Pig	716
352	Rackets, Tennis	1037	Reels, Clothes Line	1070	Key	1047
353	Racking Cocks	775	Fishing	1020, 1030	Locker	624
343	Racks, Towel	678	Garden	1062	Malleable	701
400 to 471	Whip	600	Hose	200	Pack	701
354	Rail, Barn Door	467	Trolling Line	1028	Stovepipe	790
353	Brackets, Hand	630	Refrigerator Catches	609	Trap Door, Flush	619
278	House Door	467, 468	Hinges	429, 430	Rip Saws	208 to 210
355, 356	Screws, Hand	640	Register Borders	800	Rivet Sets	284
353	Spikes, Tram	425	Faces	800	Riveting Hammers	235
578, 579	T	1082	Registering Calipers	111	Rivets and Burs	283
620 to 630	Tongs	233	Counters	139	Rivets, Belt	283
605	Railroad Adze Handles	250	Turnstiles	1076	Boiler	403
578, 579	Adzes	222	Registers, Hot Air	800	Carriage	402
167	Bolts	425	Stovepipe	800	Countersunk Head	402
201	Lantern Globes	822	Tally	139	Clinch, Slotted	284
nd Dies	Lantern Wicks	822	Reloading Tools	1007, 1008	Coopers'	403
167	Lanterns	810	Resizing Tools	1008	Copper	283
303	Pick Handles	250	Remington Guns	979, 982, 983	Coppered Iron	283
205	Picks	247	Rifles	989	Iron	402, 403
167	Spike Mauls	243	Repair Links	368	Tinners'	403
292, 293	Spikes	425	Repeating Rifles	980 to 991	Weights of	1087
310	Track Tools	232, 233	Shot Guns	982	Roasting Pans	783, 792

P
Q
R
S
T
U
V
W
X
Y
Z

Index

R	PAGE	R	PAGE	S	PAGE
Robes, Lap	089	Rules, Boxwood	134 to 136	Sash Tools	584
Rod Couplings, Pump	303	Caliper	134, 137	Weights	601
Ferrules	1033	Chesterman's	132	Sauce Pans	786
Nuts, Wagon Box	411	Comparative Numbers of	133	Saucers	783
Rods, Brass	680	Folding	131	Sausage Stuffers	750
Drawn	1080	Gunther's Slide	134	Saw Blades, Bracket	179
Fishing	1031, 1032	Ivory	137	Blades, Butchers'	211
Gauging	137	Key Seat	131	Blades, Compass	211
Gun Cleaning	1005, 1006	Log	138	Blades, Hack	105
Saw	207	Machinists'	130, 131	Blades, Key-Hole	211, 211
Stair	682	Steel	130 to 132	Blades, Nest of	211
Wantage	137	Rulers, Desk	137	Blades, Pruning	211
Roll, Brass	325	Russia Sheet Iron (Imitation)	327	Blades, Scrolling	167
Roller, Bushings	348			Blades, Turning	211
Buckles	705			Blades, Wood	211
Snaps	703			Buck's	207
Rollers, Barn Door	467			Clamps	106
Sash	606			Files	87 to 91
Shade	680			Frames, Hack	194, 195
Stay	407			Frames, Wood	207
Towel	630			Gauges	188, 189
Rolling Pins	750			Gummers	189
Roofing, Corrugated	327			Gummer Cutters	189
Nails	423			Handles, Compass	211
Roofing Paper	381			Handles, Cross-Cut	205
Root Baskets	757			Handles, Hand	259
Root's Blowers	1070			Handles, Panel	259
Rope Clips	300			Knives	213
Cotton	370			Rods	207
Galvanized Wire	360			Screws	207
Halters	604			Sets	180, 187
Manilla	370			Swages	187
Sisal	370			Tools	180 to 189
Snaps	702, 703			Vises	72
Sockets	300			Webbs	211
Steel Wire	300			Saws, Back	210
Strength of	309			Band	209
Weight of	309			Buck	206, 207
Wire	300			Butchers'	212, 213
Rose Chucking Reamers	3			Circular	200
Rose and Escutcheons	516			Combination	208
Rosin	381			Compass	211
Round Head Screws	410, 417			Cross Cut	202 to 205
Head Stove Bolts	397			Dehorning	213
Nose Pliers	39, 42			Hack	104, 105
Point Shovels	1005			Hand	208 to 210
Router Planes	185			Ice	201
Rcw Locks	303			Key-Hole	211
Rubber Belting	277			Kitchen	213
Cement	102			Meat	212, 213
Foot Balls	1040			Nest of	211
Hose	287			Pad	211
Solution	102			Panel	208 to 210
Spring Bumpers	287			Pit	201
Tubing	287			Pork Packers'	213
Window Cleaners	300			Pruning	211
Rudder Braces	300			Rip	208 to 210
Rules, Architects'	135			Scroll and Lathes	197 to 199
Blacksmiths'	132			Slitting	1
Board	138			Turning	211

Index

PAGE

S

PAGE

S

PAGE

S

PAGE

Saws, Whip 201
 Wood 206, 207
 Scale Weights 738, 739
 Scales, Avery's 737, 738
 Bathroom 723
 Butchers' 727 to 730
 Butter 730
 Candy 736
 Champion 723
 Counter 726 to 738
 Dispensing 736
 Druggists' 735, 736
 Fish 725
 Gold 249, 735
 Letter 729
 Tea 730, 737, 738
 Scandinavian Padlocks 544, 551
 School Crayons 374
 House Bells 532
 House Hooks 669
 Seissors, Bankers' 909, 910
 Barbers' 909
 Button-Hole 919
 Grape 970
 In Cases 923 to 925
 Manicure 921, 922
 Nail 920 to 922
 Paper Hangers 909
 Pocket 910, 917, 918, 920
 Tailors' 911
 Scoops, Coal 1068, 1069
 Cheese 969
 Furnace 1068
 Grain 1068, 1069
 Scotch Bowls 1038
 Planes 178, 179
 Scraper Planes 183
 Scrapers, Box 204
 Deck 359
 Drag 1074
 Coopers' 176
 Foot 1075
 Road 1074
 Ship 359
 Vencer 183
 Scraping Knives 928
 Scratch Awls 150
 Brushes 336
 Gauges 116
 Screen Door Catches 562
 Door Hinges 442, 447
 Door Pulls 578, 579
 Door Springs 450
 Doors 331
 Wire Cloth 331
 Screens, Sand 328
 Window 330
 Screw Clamps 75, 70
 Cock Eyes 70
 Driver Bits 171

Screw Drivers 155 to 157
 Driver Handles 201
 Eyes 653 to 655
 Hitching Rings 700
 Hook and Strap Hinges 454
 Hooks and Eyes 650
 Hooks, Brass 618
 Hooks, Wire 651, 652
 Plates 5 to 16
 Pulleys 354
 Rings, Brass 648
 Slotting Cutters 4
 Screws, Bench 71
 Brass 417
 Cap 390
 Clamp 74
 Cheese Press 77
 Cider Press 77
 Coach 385
 Cork 778 to 782
 Hand 75
 Hand Rail 640
 Iron 416
 Jack 341, 342
 Knob 515
 Machine 388
 Saw 297
 Set 399
 Vise E x 63
 Scribes, Timber 130, 853
 Scribing Blocks 114
 Scroll Saws and Lathes 197 to 199
 Scroll Saw Blades 197
 Scrub Brushes 388
 Scythe, Snaths 1054
 Stones 100, 101
 Scythes 1055
 Seaming Brushes 386
 Searchers 892
 Seats, Store 1070
 Seeders, Raisin 743
 Self Measuring Faucets 777
 Servers 890
 Salad 971
 Set, Collars 323
 Screws 399
 Sets, Auger Bit 164
 Awl and Tool 159 to 162
 Carving 943, 944
 Carving Tool 149, 151
 Child's, Plated 962
 Fish Carver 966
 Garden 1051
 Gun Implements 1005
 Mathematical 112
 Nail 172
 Oiler 322
 Rivet 284
 Saw 186, 187
 Work Box 805

Sewing Awl Hafts 201
 Awls 158
 Machine Oilers 319
 Machine Pliers 40
 Shackles, Chain 391
 Shade Roller Brackets 680
 Rollers 680
 Shaft, Chimes 691, 692
 Collars 323
 Coupling 323
 Shafting 323
 Shuffling Hangers 323
 Shakers, Spun 770
 Shavers, Dried Beef 746
 Shaves, Backing 175
 Heading 175
 Hoop 175
 Spoke 153, 154, 176
 Shaving Brushes 896, 897
 Soap 896
 Shears, Bankers' 909, 910
 Barbers 909
 Bench 41
 Grasping 1060
 Grass 1059
 Hand 44
 Horse Clipping 923
 Paper 909, 910
 Pruning 1069
 Sheep 1061
 Tailors 911
 Tinnern 44
 Sheath Knives 888
 Sheathing Paper 381
 Sheaves, Iron 350, 351
 Shutter 468
 Sliding Door 468
 Sheep Bells 593
 Shears 1061
 Toe Trimmers 1060
 Sheet Aluminum 324
 Brass 325
 Decarbonized Steel 1081
 Glue 102
 Iron, Black 1081, 1085
 Iron, Galvanized 327, 1085
 Iron, Gauges of 1085
 Iron, Planished 327
 Russia Iron 327, 1085
 Steel or Iron 1081
 Zinc 327
 Shelf Brackets 637
 Shell Extractors 1003
 Loaders 1003, 1005
 Reamers 4
 Shells, Loaded 997, 998
 Shot 997, 998
 Shields, Eye 253
 Shingle Nails 423, 424

R
S
T
U
V
W
X
Y
Z

Index

S	PAGE	S	PAGE	S	PAGE
Shingling Hatchet Handles	258	Singers, Horse	684	Snaps, Harness	702, 703
Hatchets	224	Silk Flags	823	Rope	694, 702
Ship Adze Handles	250	Silver-Plated Knives and Forks	961	Swivel	701
Adzes	222	Polish	92	Snatch Blocks	347, 348, 357
Augers	166	Solder	200	Snaths, Scythe	1054
Axes	220	Trays, Carpathian	806	Snips, Tinnerns'	44
Carpenters' Bevels	124	Singletree Ferrules	400	Snow Shovels	1039
Lanterns	821	Hooks	400	Soap Dishes	787
Mauls	244	Tongues	409	Sockets, Drill	1
Scrapers	359	Singletrees, Ironed	230	Sash Pull	605
Shoe Brushes	388, 389	Sink Bolts	307	Whip	636
Daubers	388	Sinkers, Lead	1034	Soft Brass, Sheet	325
Hammers	235	Sinks, Steel	708	Brass Wire	833
Iron, Horse	1080	Sisal Bed Cord	370	Copper Wire	333
Knives	929	Rope	370	Solder, Silver	290
Lasts	717	Skate Straps	1019	Tinnerns'	324
Nails, Horse	414	Wrenches	1019	Soldering Coppers	48
Pincers	43	Skates, Hockey	1016 to 1019	Furnaces	45 to 47
Rasps	87, 90, 91	Ice	1014 to 1019	Sets	48
Steel, Sleigh	1081	Parts of	1019	Solid Bolt Dies	43
Thread	372	Racing	1017, 1018	Box Vises	63
Shoeing Hammers	238	Skew Rabbet Planes	178	Dies and Taps	15
Shoemakers' Awls	158	Skewers	708	Reamers	3
Hammers	235	Skidding Tongs	230	Soup Ladles	972
Shoes, Horse	412, 413	Skinning Knives	932 to 934	Plates	783
Shot, Buck	909	Skins, Chamois	818	Spade Handles	1053
Cartridges	995	Slab Zinc	324	Lifters	1053
Chilled	900	Slating Nails	423	Spades and Shovels	1065
Gun Covers	1010	Sledge Handles	258	Butter, Tinned	926
Guns	979 to 986	Sledges, Blacksmiths'	230, 240	Butter, Wood	759
Measures	1004, 1005	Cast Iron	230	Clay	1066
Pitching	1040	Stone	245	Ditching	1066
Shells	979 to 986	Sleeves, Socket	1	Draining	1067
Split	1034	Sleigh Bells	990 to 993	Post Hole	1066
Shovel Handles	1053	Shoe Bolts	396	Spading Forks	1049
Shovels, Fire	798	Shoe Steel	1081	Spalling Hammers	251
Moulders'	1068	Slicers, French Cook	936	Speaking Tubes	802, 804
Sand	1068	Ham	937	Tube Collars	804
Snow	1069	Slicks, Carpenters'	149	Tube Elbows	802
Spades and	1065	Slide Head Nails	679	Tube Whistles	803
Show-case Catches	533	Slides, Breast Strap	705	Specific Gravities	1088
Locks	533	Sliding Door Hangers	462 to 466	Spectacles	1017
Shrinkage of Castings	1088	Latches	508, 509	Speed Indicators	104, 105
Shrinkers, Tire	267	Locks, Mortise	510	Spelter	321
Shredders, Ice	703	Rail	468	Spice Mills	740 to 742
Shutter Bars	666	Rollers	467	Spike Mauls	243, 241
Butts	431	Sheaves	468	Spikes, Bolt	425
Knobs	607	Track	467	Boot	228, 1039
Sheaves	468	T Bevels	124	Cut	423
Sickles, Grass	1055	Slips, Axe	97	Marline	359
Sidewalk Cleaners	1051	Oil	98, 99	Railroad	425
Sieves and Riddles	328	Slitting Saws	4	Wire	421
Flour	328	Slotted Rivets	284	Spindles, Knob	515
Sand	328	Smoked Beef Shavers	746	Spinners, Brass	1023 to 1027
Seed	328	Smokeless Cartridges	906	Trout	1027
Sifters, Ash	329	Powder	900	Spiral Screw Drivers	155 to 159
Flour	765	Shells	908	Spittoons	793
Sights, Level	126	Snaps, Bag	704	Splicing Clamps	90
Rifle	1008, 1009	Bit	702	Spint Baskets	757
Signs, Enamelled	1077	Bull	706	Split Shot	1034

Index

S

PAGE

Split Pulleys	278
Splitters, Beef	751
Splitting Knives	934
Spoke Pointers	160
Shave Irons	154
Shaves	153, 154
Spoiled Wire	333
Spoon Baits	1023 to 1027
Bits	163
Spoons, Bar, Plated	772
Basting	785, 973
Coffee	976, 978
Dessert	973 to 977
Jam	971
Post Hole	1067
Sterling Silver	977
Silver-Plated	975 to 977
Sugar, Plated	971
Table	973 to 977
Tea	973 to 977
Telegraph	1007
Tinned	973
Trolling	1023 to 1027
Wood	759
Spouts, Sap	794
Spray Pumps	290
Spring Buck Knives	888, 887
Bolts	567, 570
Bumpers	287
Butts	445, 440
Calipers	107
Catches	610
Dividers	107
Hinges	442 to 447
Punch Tubes	280
Punches	280
Steel	1081
Tapes	140 to 143
Window Bolts	601
Wire	332, 333
Springs, Bird Cage	660
Door	448 to 450
Seat	335
Wire	335
Sprinklers, Lawn	288 to 290
Sprocket Wheels	276
Spuds, Dandelion	1050
Square Nuts	400
Point Shovels	1065
Reamers	171
Square Shank Drills	2
Squares, Centre	121
Iron	122
Nickel-Plated	122
Steel	121, 122
Try and Bevel	119 to 124
Try, Combination	119
Squeezers, Lemon	766
Stable Brooms	391
Fixtures	608, 609

S

PAGE

Stair Plates	682, 1075
Rail Screws	640
Rods	682
Stall Fixtures	714
Staples, Barbed Blind	458
Barrel	458
Bed	458
Fence	458
Hame	705
Hasps and	455
Hooks and	455, 456
Hooks, Hasps and	456
Poultry Netting	458
Rings and	701
Wrought	458
Star Safety Razors	901
Starters, Bung	170
Stay Rollers	407
Steak Hammers	745
Steam Cocks	300
Gauges	314
Packing	365
Steamboat Oiler Sets	322
Steamers, Pieced	789
Steel, Bar	1080
Breast Chains	713
Chains, Surveyors'	143, 144
Figures	265
Heads	1081
Horse Shoes	413
Letters	295
Nuts on	1086
Machinery	1081
Measuring Tapes	140, 144
Oilers	319 to 322
Plate	1081
Rules	130 to 132
Scrapers, Drag	1074
Shafting	323
Sheet	1081
Sinks	708
Skates	1014 to 1019
Sleigh Shoe	1081
Sockets	1
Spring	1081
Squares	121, 122
Stubs, Cast	333
Tire	1081
Toe Calk	1081
Toe Calks	414
Traps	1013
Trays	809
Weights of	1080
Wheelbarrows	1073
Wire	332, 333
Wool	290
Steels, Butchers'	945
Table	946 to 948
Steelyards	720
Steepers, Tea	784

S

PAGE

Stencil Alphabets	245
Step Ladders	700
Sterling Silver Spoons and Forks	977
Sticking Knives	1022 to 934
Sticks, Candle, Miners'	240
Fencing	1041
Golf	1038
Hockey	1010
Lacrosse	1037
Mop	757
Single	1041
Yard	137
Stocks and Dies, Bolt	7 to 16
and Dies, Pipe	25 to 28
Angular, Bit	56
Drill	49
For Screw Plates	12
Stone Axes	244
Cutters' Mallets	263
Masons' Hammers	244, 245
Picks	245
Sledges	245
Stoners, Cherry	743
Stones, Axe	97
Grind, Kitchen	96
Grind, Loose	96
Grind, Mounted	96
Oil	97 to 99
Scythe	100, 101
Table	100
Stop and Waste Cocks	312
Cock Boxes	312
Stoppers, Bottle	773
Stops, Bench	174
Door	576
Floor	576
Flue	796
Sash, Adjustable	598
Store Door Dead Locks	487 to 489
Door Handles and Latches,	557 to 561
Door Handles and Locks	557, 558
Door Keys	517, 518
Door Locks, Mortise	498
Door Locks, Rim	487 to 489
Seats	1076
Storm Glasses	255
Stove Backs	797
Boards	797
Bolt Taps	18
Bolts	397
Brushes	388
Enamel	799
Lifters	798
Pipe	790
Pipe Collars	790
Pipe Dumpers	797
Pipe Elbows	796
Pipe Registers	800
Pipe Thimbles	797

Index

S	S	T
PAGE	PAGE	PAGE
Stove Polish	Swivel Vises	Tanged Turning Gouges
700	60, 47	146
Shovels	Swivels, Brass Box	Tap Borers
708	1033	170
Varnish	Double	Wrenches
709	704	15, 17
Wick	Hook and Spring	Tape, Insulating
822	1033	1001
Stoves, Cook	Syringes, Garden	Lines
705	200	140 to 144
Pocket		Taper Reamers
806		3, 5
Straight Shank Drills		Saw Files
1		89 to 94
Trimmers		Shank Drills
910		1
Way Valves		Taps
308		18 to 20
Strainer Cloth		Tapes, Girthing
330		149
Pails		Measuring
789		140 to 144
Strainers, Julp		Pocket
771		140
Milk, Stamped		Tailors'
788		140
Suction Pipes		Taps and Dies
205		6 to 28
Strap and T Hinges		Champagne
452, 453		773
Hinges, Screw		Liquor
454		774 to 777
Straps, Cow Bell		Pipe
503		20
Hose		Plug
280		18, 19
Pipe		Taper
306		18 to 20
Razor		Tar, Coal
898 to 900		381
Skate		Target Pigeons
1019		1012
Speaking Tube		Traps
802		1012
Straw Board		Tarred Felt
381		381
Stretchers, Carpet		Tea Bells
756		594
Wire		Kettles
1070		784, 790
Strikes, Rim Lock		Pots
470, 483		784, 798
Striking Bag Bladders		Scales
1043		737, 738
Bags		Spoons
1042		973 to 977
Gloves		Steepers
1042		781
Hammers		Trays
243		809
String, Bag, etc		Team Bells
372		691
Strips, Weather		Tea Steel
598		1081
Stropping Machines		Tees, Branch
900		306
Strops, Razor		Cast Iron
898 to 900		305
Stub's Cast Steel		Malleable
333		304
Files		Teeth, Threshing Machine
91		401
Screw Plates		Telegraph Spoons
15		1067
Wire Gauges		Vises
113		73
Studs, Belt		Telescopes
282		252
Iron		Tennis Balls
309		1037
Stuffers, Sausage		Markers
750		1038
Suction Hose		Nets
257		1038
Pipe Strainers		Poles
205		1038
Sugar Spoons		Rackets
971		1037
Tongs		Tenon Saws
972		210
Surcingles or Girths		Tent Hooks and Eyes
689		358
Surface Gauges		Tents
114, 115		373
Surveyor's Chains		Testing Machines, Iron
144		387
Pins		Thermometers
144		254, 255
Swabs, Gum		Thimbles, Chimney
1004		797
Swage Blocks		Galvanized Rope
209		390
Swages, Blacksmiths'		Thistle Spuds
241		1050
Saw		Thread Chasers
187		20
Swedes, Iron		Shoe
1080		372
Iron Tacks		Threshing Machine Teeth
418		404
Sweepers, Carpet		Thumb Latches
750		563 to 565
Swiss Files		Nuts
91		304, 411
Swivel Pulleys		Screws
355		304
Snaps		Ticket Punches
704		281
Spindles		Tie Chains
515		712

Index

PAGE
 es..... 116
 170
 15, 17
 1001
 140 to 141
 3, 5
 89 to 91
 1
 18 to 20
 110
 140 to 141
 110
 110
 6 to 28
 773
 774 to 777
 20
 18, 19
 18 to 20
 381
 1012
 1012
 381
 591
 784, 790
 784, 798
 737, 738
 973 to 977
 781
 809
 991
 1081
 306
 305
 303
 ine..... 401
 1067
 73
 252
 1037
 1038
 1038
 1037
 210
 358
 373
 337
 254, 255
 797
 300
 1050
 29
 372
 h..... 401
 563 to 565
 394, 411
 394
 281
 712

T	PAGE
Tie Chains, Cow.....	713 to 715
Ropes.....	604
Tighteners, Wire Fence.....	1070
Till Keys.....	510
Lecks.....	522 to 528
Tills, Alarm.....	721
Tin, Bar.....	324
Ingot.....	324
Tinned Carpet Tacks.....	418
Wire.....	332, 333
Tinners' Cutting Nippers.....	41
Hammers.....	235
Mallets.....	203
Rivet Sets.....	284
Shears, Bench.....	44
Solder.....	324
Soldering Coppers.....	48
Tinware.....	788 to 793
Timber Gauges.....	130
Girthing Tapes.....	140
Grapples.....	230
Scribes.....	130, 853
Tips, Lava.....	311
Tire Benders.....	207
Bolt Holders.....	6
Bolts.....	306
Measuring Wheels.....	6
Steel.....	1081
Shrinkers.....	207
Upsetters.....	207
Tobacco Cutters.....	722
Toe Calk Steel.....	1081
Calks.....	414
Plates.....	1036
Toilet Clippers.....	683
Fixtures.....	682
Paper.....	682
Tongs, Blacksmiths'.....	43
Cinch.....	43
Curling.....	816
Hog.....	716
Ice.....	793
Pipe, Gas.....	30
Rail.....	233
Skidding.....	230
Sugar.....	972
Timber.....	230
Tonguing and Grooving Planes—	
Adjustable.....	183, 184
Wood.....	178
Tool Baskets.....	204
Chests.....	190, 191
Steel.....	1082
Tools, Awls and.....	150 to 162
Belt.....	279
Blacksmith's.....	241, 242, 209
Carving.....	149 to 151
Coopers.....	175 to 177
Draining.....	1007
Harvesting.....	1048

T	PAGE
Tools, Ice.....	231
Loading.....	1003 to 1005
Lumbering.....	227 to 230
Pump.....	167
Reloading.....	1007
Sash.....	384
Saw.....	188, 189
Track.....	232, 233
Tooth Gauges, Saw.....	188, 189
Plane Irons.....	154
Rasps, Horse.....	86
Toothing Planes.....	183
Tops, Malleable D.....	1053
Torches, Gasoline.....	45 to 47
Towel Pins.....	673
Racks.....	678
Rollers.....	639
Tower Bolts.....	567
Trace Chains.....	712
Tracing Wheels.....	817
Track, Barn Door.....	467
Sliding Door.....	407, 468
Tools.....	232, 233
Trolleys.....	317
Trammel Points.....	105
Trancon Catches.....	613
Centres.....	605
Chains.....	614
Lifters.....	615 to 617
Trap Clamps, Bear.....	76
Door Rings and Staples.....	101
Door Rings, Flush.....	619
Traps, Bear.....	1013
Blue Rock.....	1012
Fly.....	765
Game.....	1012
Mouse.....	814, 815
Rat.....	814, 815
Steel.....	1013
Target, Pigeon.....	1012
Trays, Tea.....	809
Tree Pruners.....	1059
Triers, Butter.....	927
Cheese.....	927
Trimmers' Bent.....	910
Hedge.....	1059
Sheep Toe.....	1059
Spoke.....	167
Straight.....	910
Trimnings, Cabinet.....	620 to 635
Trimo Chain Wrenches.....	30
Pipe Wrenches.....	31, 32
Trip Gongs.....	591
Trolley Barn Door Hangers.....	464
Fire Door Hangers.....	464
House Hangers.....	463
Trolleys, Track.....	347
Trolling Baits.....	1023 to 1027
Lines.....	1028
Spoons.....	1023 to 1027

T	PAGE
Trolling Reels.....	1028
Troughs, Horse.....	300
Trout Flies.....	1022
Trowel Shank Carvers.....	937
Trowels, Brick.....	256
Corner.....	1061
Garden.....	1061
Gauging.....	256
Plastering.....	257
Pointing.....	256
Troy Polishing Irons.....	755
Truck Casters.....	645
Trucks, Bag.....	718
Factory.....	718, 719
Handy.....	718
Hotel.....	718
Railroad.....	718, 719
Store.....	718
Trunk Catches.....	542, 543
Hinges.....	433
Key Blanks.....	521
Locks.....	537 to 542
Rollers.....	600
Truss Hoops.....	177
Try Squares.....	110 to 121
Tube Cleaners.....	163
Skates.....	1018
Speaking.....	802
Whistles.....	803
Boiler.....	392
Glass, Gauge.....	315
Punch, Spring.....	280
Tubing, Brass.....	325
Copper.....	325
Lead Pipe.....	325
Rubber.....	287
Tubular Lanterns.....	819, 820
Lantern Burners.....	822
Lantern Globes.....	822
Lantern Wick.....	822
Tueking Jointers.....	257
Tugs Hame Clip.....	705
Turf Edgers.....	1050
Turkey Emery.....	92
Feather Dusters.....	390
Turnbuckles, Iron.....	394
Galvanized.....	357
Turn Screws.....	155 to 156
Turn Screw Handles.....	261
Turning Chisels.....	140
Gauges.....	147
Hammers.....	240
Webs.....	214
Turnstiles, Registering.....	1076
Turns, Cupboard.....	612, 613
Tuyere Irons.....	288, 1079
Tweezers.....	805
Twine Boxes.....	721
Cotton.....	372
Flax.....	372

Index

T	V	W
PAGE	PAGE	PAGE
Twine, Hemp	Vises, Oval Slide	Welds, Turning
372	68	211
Jute	Parkers'	Wedges, Axe
372	67	219
Wrapping	Pipe	Stone
372	60, 61, 69	212
Twist Drills	Planer	Wood Choppers
1	62	212
Twisters, Police	Saw Filers	Weed Cutters
1046	82	1050
	Simpson's	Weeding Hoes and Rakes
	68, 70	1050
	Sold Box	Weights and Tables
	63	1083 to 1089
	Swivel	Weights, Hitching
	60, 67	607
		Of Bar Iron
		1081
		Of Bolts
		1087
		Of Circular Heads
		1085
		Of Floor Glass
		1086
		Of Metals
		1088
		Of Precision
		739
		Of Rope
		309
		Of Sheet Iron
		1085
		Of Windows
		604
		Sash
		604
		Scale
		738, 739
		Well Points, Drive
		235
		Pumps
		293
		Wheels
		351
		Wheel Barrows
		1071 to 1073
		Wheel Heads
		709
		Wheels, Barrow
		1072
		Buffing
		94
		Cast Iron
		350
		Emery
		94
		Sprocket
		276
		Tire Measuring
		6
		Tracing
		817
		Well
		351
		Whetstones
		101
		Whiffletree Centre Irons
		410
		Clevises
		410
		Clips
		410
		Couplings
		409
		End Irons
		230
		Ferrules
		409
		Hooks
		409
		Tongues
		409
		Whip Racks
		696
		Saws
		201
		Sockets
		696
		Whips, Dog
		711
		Driving
		695
		Egg
		705
		Whistle Valves, Steam
		313
		Whistles, Speaking Tube
		803
		Steam
		313
		White Lead
		380
		Whitewash Brushes
		387
		Winches, Hoisting
		345
		Wicks, Lamp
		822
		Lantern
		822
		Oil Stove
		822
		Wicket Gauntlets
		1039
		Wickets, Cricket
		1039
		Winchester Rifles
		989
		Shot Guns
		982

Index

W	PAGE
.....	211
.....	219
.....	242
pers.	242
.....	1050
d Rakes	1050
es	1083 to 1080
g	697
.....	1081
.....	1087
Heads	1085
ss	1086
.....	1088
.....	730
.....	330
n	1085
.....	604
.....	604
.....	738, 739
.....	205
.....	203
.....	351
.....	1071 to 1073
.....	709
.....	1072
.....	94
.....	350
.....	94
.....	276
ng	6
.....	817
.....	351
.....	101
Irons	410
.....	410
.....	410
.....	409
.....	230
.....	409
.....	400
.....	400
.....	400
.....	696
.....	201
.....	696
.....	711
.....	695
.....	765
eam	313
Tube	303
.....	313
.....	380
s	387
.....	345
.....	822
.....	822
.....	822
.....	1039
.....	1030
.....	989
.....	982

W	PAGE
Window Bolts, Spring	601
Brushes	330
Catches, Casement	614
Catches, French	610, 611
Chains	614
Cleaners, Rubber	330
Cord	371
Glass	379, 380
Locks	601
Screens	330
Stop Adjusters	598
Weights	604
Windows, Weight of	694
Windsor Sauce Pans	780
Wing Calipers	110
Dividers	110
Wipers, Gun	1003, 1004
Wire, Annealed	332
Barbed	335
Belt Lacing	282
Brads	424
Brass	333
Bright, Iron	332
Cable	369
Cloth, Hardware Grade	330
Cloth Screen	331
Cloth Strainer	330
Clothes Line	370
Coat and Hat Hooks	606 to 608
Coil Chain	707
Connecting	1001
Copper	333
Coppered Steel Spring	332
Cutting Nippers	37, 41, 42
Cutting Pliers	37, 41, 42
Door Springs	450
Fence Staples	458
Fence Tighteners	1070
Fencing, Woven	334
Galvanized	332
Gauges	113
Hair	333
Music	333
Nails	424
Picture Cord	681
Poultry Netting	334
Poultry Netting Staples	458
Rings and Clips	360

W	PAGE
Wire Rope Clips	300
Rope Sockets	300
Rope	309
Screw Eyes	653 to 655
Screw Hooks	648 to 652
Springs	335
Steel	332
Strainer, Cloth	330
Stretchers	1070
Stub's, Steel	333
Tinned	332, 333
Wood Bench Screws	74
Bowls	758
Choppers' Wedges	242
Faucets	771
Hand Screws	75
Ladles	758
Measures	758
Planes	178 to 182
Rakes	1053
Rasps	89 to 91
Saw Blades	214
Saw Bucks	207
Saw Frames	207
Saw Rods	207
Saws	200, 207
Screw Boxes and Taps	174
Screws	415 to 417
Screws, Discount off	415
Split Pulleys	278
Spokeshaves	154
Spoons	759
Tackle Blocks	355
Wool Cards	684
Steel	286
Work Box Sets	805
Worms, Gun	1002
Woven Wire Fencing	334
Wrapping Paper	382
Twine	372
Wrenches, Agricultural	35
Alligator	31
Always Ready	31
Baxter S	37
Bicycle	34
Bit	160
Carriage	411
Chain Pipe	30

W	PAGE
Wrenches, Coe's	35
Combination	32, 33
Engineers	30
Gas Pipe	30
Lathe Dog	79
Malleable	411
Pipe	30 to 33
Pocket	34
Skate	1019
S	30, 37
Stillson's	32
Tap	15, 17
Vulcan	30
Wescott's	33
Wringers, Clothes	753
Wrought Butts, Brass	431
Butts, Steel	434, 435
Chest Handles	619
Hasps and Staples	456
Hinge Hasps, Brass	457
Hinge Hasps, Steel	454, 455
Hooks and Staples	455, 456
Iron Nipples	303
Iron Padlocks	552 to 550
Iron Pipe	332
Staples	458
Washers	401

X

"X" Screw Plates	7
------------------	---

Y

Yachtsman's Knife	853
Yale Casters	644
Yard Sticks	137
Yarn, Lath	370
Yoke, Axle Clip	406
Yokes, Neck	230
York Eye Term Bulls	691

Z

Zinc, Glazier Points	420
Oilers	319
Slab	324
Sheet	327

T
U
V
W
X
Y
Z

Diamet
Length
Price, e

Diamet
Length
Price, e

Diamet
Length
Price, e

F



N
e
e

Diamete
Length
Price, ea
Price, pe

Diamete
Length
Price, ea
Price, pe

Nos.
Length,
Price, ea
Price, pe

Nos.
Length,
Price, ea
Price, pe

THE MORSE TWIST DRILL AND MACHINE CO'S

TAPER SHANK DRILLS

No. 102



Diameter	1/4	5/32	3/16	11/32	3/8	13/32	7/16	15/32	1/2	17/32	9/16	19/32	5/8	21/32	11/16 inch.
Length	6 1/2	6 1/2	6 1/2	6 1/2	6 1/2	6 1/2	7 1/4	7 1/2	7 1/2	8	8 1/2	8 1/2	8 1/2	9	9 1/2
Price, each	\$0.60	0.65	0.70	0.75	0.80	0.85	0.90	0.95	1.00	1.10	1.20	1.30	1.40	1.50	1.60

Diameter	23/32	3/4	25/32	13/16	27/32	7/8	29/32	15/16	31/32	1	1 1/32	1 1/16	1 1/8	1 1/4	1 1/2 inch.
Length	9 1/2	9 1/2	9 1/2	10	10 1/2	10 1/2	10 1/2	10 1/2	10 1/2	11	11 1/4	11 1/2	11 1/2	11 1/2	12
Price, each	\$1.70	1.85	2.00	2.15	2.30	2.45	2.60	2.75	2.90	3.00	3.20	3.40	3.60	3.80	4.20

Diameter	1 1/4	1 3/16	1 3/8	1 7/16	1 1/2	1 9/16	1 5/8	1 15/16	1 3/4	1 13/16	1 7/8	1 15/16	1 1 1/16	2 inch.
Length	12 1/2	14 1/2	14 1/2	14 1/2	14 1/2	15 1/2	15 1/2	15 1/2	16	16 1/2	16 1/2	16 1/2	16 1/2	16 1/2
Price, each	\$1.50	4.80	5.20	5.60	6.00	6.00	6.00	7.20	7.80	8.10	8.80	9.20	9.50	9.80

The above we furnish in 6ths if ordered—at one size advance on list.

STEEL SOCKETS FOR MORSE TAPER SHANK DRILLS

No. 100



No. 1	Hold Drills 1/4 to 1 1/8 inclusive, each	\$1.25
" 2	" " " 1/2 " 1 1/4 " " "	1.90
" 3	" " " 3/4 " 1 3/4 " " "	2.65
" 4	" " " 1 1/2 " 2 " " "	4.20

STEEL SOCKET SLEEVES

No. 100 B



No. 1	Fitted to No. 2 or 3 Socket, each	\$1.90
" 2	" " " 3 " " "	2.50
" 3	" " " 4 " " "	3.15
" 4	" " " 1 " " "	3.15

STRAIGHT SHANK TWIST DRILLS

No. 105



Diameter	1/16	7/64	3/32	7/64	1/8	9/64	5/32	11/64	3/16	13/64	7/32	15/64	1/4	17/64	9/32 inch.
Length	2 1/2	2 1/2	2 1/2	2 1/2	3	3 1/4	3 1/4	3 1/4	3 1/2	3 3/8	3 1/2	3 3/4	4	4 1/4	4 1/2
Price, each	\$0.09	0.10	0.11	0.12	0.13	0.15	0.16	0.18	0.20	0.21	0.23	0.26	0.28	0.30	0.32
Price, per doz.	\$1.00	1.10	1.20	1.30	1.45	1.60	1.80	2.00	2.20	2.40	2.65	2.90	3.15	3.40	3.65

Diameter	19/64	5/16	21/64	11/32	23/64	3/8	25/64	13/32	27/64	7/16	29/64	15/32	31/64	1/2 inch.
Length	4 1/2	4 1/2	4 1/2	4 1/2	4 1/2	5	5 1/2	5 1/2	5 1/2	5 1/2	5 1/2	5 1/2	5 1/2	6
Price, each	\$0.35	0.37	0.40	0.42	0.45	0.48	0.50	0.53	0.55	0.59	0.63	0.65	0.67	0.70
Price, per doz.	\$3.90	4.20	4.50	4.80	5.10	5.40	5.70	6.00	6.40	6.80	7.20	7.50	7.75	8.00

Straight Shank Drills over 1/2 inch, same list as Taper Shank.

STRAIGHT SHANK TWIST DRILLS

No. 107

Stub's Steel Wire Gauge sizes.

No.	1 to 5	6 to 10	11 to 15	16 to 20	21 to 25	26 to 30
Length, inch	4	3 1/4	3 1/2	3 1/4	3 1/8	2 1/4
Price, each	\$0.22	0.21	0.20	0.19	0.17	0.15
Price, per doz.	\$2.35	2.25	2.10	1.95	1.75	1.55

No.	31 to 35	36 to 40	41 to 45	46 to 50	51 to 60	61 to 70
Length, inch	2 3/8	2 7/8	2 1/2	2 1/8	1 3/4	1 1/2
Price, each	\$0.14	0.12	0.10	0.09	0.09	0.08
Price, per doz.	\$1.40	1.25	1.10	0.95	0.95	0.90

See page 113 for corresponding Wire Gauge and Decimal sizes.

STRAIGHT SHANK DRILLS

No. 112



With Shanks $\frac{1}{2}$ inch Diameter.

Diameter.....	$\frac{1}{8}$	$\frac{5}{32}$	$\frac{3}{16}$	$\frac{7}{32}$	$\frac{1}{4}$	$\frac{9}{32}$	$\frac{5}{16}$	$\frac{11}{32}$	$\frac{3}{8}$	$\frac{13}{32}$	inch.
Length.....	5 $\frac{1}{2}$	5 $\frac{3}{4}$	5 $\frac{3}{4}$	5 $\frac{3}{4}$	6	6	6	6	6	6	"
Price, each....	\$0.45	0.45	0.50	0.55	0.60	0.65	0.70	0.73	0.75	0.78	
Diameter.....	$\frac{7}{16}$	$\frac{15}{32}$	$\frac{1}{2}$	$\frac{17}{32}$	$\frac{9}{16}$	$\frac{19}{32}$	$\frac{5}{8}$	$\frac{21}{32}$	$\frac{11}{16}$	$\frac{3}{4}$	inch.
Length.....	6	6	6	6	6	6	6	6	6	6	"
Price, each....	\$0.80	0.83	0.85	0.88	0.90	1.00	1.05	1.10	1.15	1.25	

STRAIGHT SHANK MACHINE BITS FOR WOOD

No. 108



Diameter.....	$\frac{1}{8}$	$\frac{5}{32}$	$\frac{3}{16}$	$\frac{7}{32}$	$\frac{1}{4}$	$\frac{9}{32}$	$\frac{5}{16}$	$\frac{11}{32}$	$\frac{3}{8}$	$\frac{13}{32}$	$\frac{7}{16}$	$\frac{15}{32}$	$\frac{1}{2}$	inch.
Length.....	3	3 $\frac{1}{4}$	3 $\frac{1}{4}$	3 $\frac{3}{4}$	4	4 $\frac{1}{2}$	4 $\frac{1}{2}$	4 $\frac{3}{4}$	5	5 $\frac{1}{2}$	5 $\frac{1}{2}$	5 $\frac{3}{4}$	6	"
Price, each....	\$0.25	0.30	0.40	0.45	0.50	0.55	0.63	0.70	0.80	0.88	0.95	1.00	1.06	
Diameter.....	$\frac{17}{32}$	$\frac{9}{16}$	$\frac{5}{8}$	$\frac{11}{16}$	$\frac{3}{4}$	$\frac{13}{16}$	$\frac{7}{8}$	$\frac{15}{16}$	1	$\frac{11}{16}$	$\frac{13}{8}$	$\frac{13}{16}$	$\frac{13}{4}$	inch.
Length.....	6 $\frac{1}{2}$	6 $\frac{1}{2}$	6 $\frac{1}{2}$	7	7 $\frac{1}{2}$	8	8 $\frac{1}{2}$	9	9 $\frac{1}{2}$	11 $\frac{1}{2}$	11 $\frac{3}{4}$	12	12 $\frac{1}{2}$	"
Price, each....	\$1.20	1.25	1.45	1.70	2.10	2.45	2.90	3.30	3.75	4.50	5.00	5.50	6.00	

The above we can furnish if ordered with Morse Taper or half inch Diameter Shanks.

BIT STOCK DRILLS FOR METAL OR WOOD

No. 109



Diameter.....	$\frac{1}{16}$	$\frac{3}{32}$	$\frac{1}{8}$	$\frac{5}{32}$	$\frac{3}{16}$	$\frac{7}{32}$	$\frac{1}{4}$	$\frac{9}{32}$	inch.
Price, each....	\$0.14	0.16	0.20	0.24	0.29	0.33	0.38	0.43	
Price, per doz.	\$1.50	1.65	2.10	2.60	3.10	3.00	4.10	4.70	
Diameter.....	$\frac{5}{16}$	$\frac{11}{32}$	$\frac{3}{8}$	$\frac{13}{32}$	$\frac{7}{16}$	$\frac{15}{32}$	$\frac{1}{2}$	$\frac{5}{8}$	inch.
Price, each....	\$0.48	0.54	0.62	0.68	0.75	0.82	0.87	1.35	
Price, per doz.	\$5.40	6.30	7.20	8.00	8.80	9.60	10.30	16.20	

TAPER SQUARE SHANK DRILLS FITTING RATCHETS

No. 109 E



With Shanks $\frac{3}{8}$ in. by $\frac{3}{8}$ in. and $1\frac{1}{2}$ in. long, and Shanks $\frac{1}{2}$ in. by $\frac{1}{2}$ in. and $1\frac{1}{2}$ in. long.

Diameter.....	$\frac{1}{4}$	$\frac{5}{16}$	$\frac{3}{8}$	$\frac{7}{16}$	$\frac{1}{2}$	$\frac{5}{8}$	$\frac{3}{4}$	$\frac{7}{8}$	1	$1\frac{1}{8}$	$1\frac{1}{4}$	inch.
Length.....	5	5	6	6 $\frac{1}{2}$	6 $\frac{1}{2}$	6 $\frac{1}{2}$	6 $\frac{1}{2}$	7 $\frac{1}{2}$	8 $\frac{1}{2}$	9	9	"
Price, each....	\$1.25	1.40	1.50	1.55	1.65	1.75	1.95	2.55	3.20	3.90	4.55	

In ordering Taper Square Shank Drills, please furnish drawing showing the square of the Shank and its length.

SOLID REAMERS

No. 118



1 1/16 inch.
0
0.78
3/4 inch.
0
1.25

Diameter.....	1/4	5/16	3/8	7/16	1/2	9/16	5/8	11/16	3/4	13/16	7/8	15/16	1	1 1/16	inch.
Flute, length...	2 7/8	2 1/2	2 3/4	2 7/8	2 7/8	2 3/4	2 3/4	2 3/4	3	3 3/4	3 1/2	3 1/2	3 3/4	3 3/4	"
Price, each....	\$1.95	2.10	2.25	2.40	2.55	2.70	2.85	3.10	3.30	3.50	3.75	4.05	4.35	4.65	

Diameter.....	1 1/8	1 1/16	1 1/4	1 5/16	1 3/8	1 7/16	1 1/2	1 9/16	1 5/8	1 11/16	1 3/4	1 13/16	1 7/8	2	inch.
Flute, length...	4	4 1/4	4 1/2	4 3/4	5	5 1/4	5 1/2	5 3/4	5 3/4	5 3/4	6	6 1/4	6 1/2	6 3/4	"
Price, each....	\$4.95	5.25	5.55	5.85	6.15	6.65	7.10	7.80	8.55	9.30	10.05	10.65	11.45	12.45	

TAPER REAMERS

No. 118

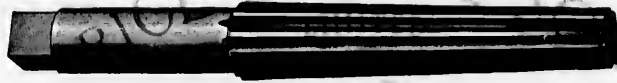

1 5/16 1/2 inch.
5 3/4 0
1.00 1.08
1 1/16 1 1/4 inch.
12 12 1/2
5.50 6.00

MORSE TAPER

No. 0	Length of Flute	2 1/2 inch, tapers	.375 to	.258	each	\$2.40
" 1	"	3 1/2 "	.5415 "	.365	"	3.00
" 2	"	4 1/2 "	.797 "	.572	"	3.90
" 3	"	5 "	1.025 "	.775	"	5.10
" 4	"	5 1/2 "	1.303 "	1.021	"	6.30

ROSE CHUCKING REAMERS

No. 120



3/82 inch.
0.43
4.70
5/8 inch.
1.35
4.55

Diameter.....	1/4	5/16	3/8	7/16	1/2	9/16	5/8	11/16	3/4	13/16	7/8	15/16	1	inch.
Full Length...	6	6	7	7	8	8	9	9	9 1/2	9 1/2	10	10	10 1/2	"
Flute, length...	1 1/2	1 1/2	1 3/4	1 3/4	2	2	2 1/4	2 1/4	2 1/2	2 1/2	2 3/4	2 3/4	2 3/4	"
Price, each....	\$1.20	1.35	1.50	1.65	1.80	1.95	2.10	2.25	2.40	2.55	2.70	2.95	3.15	

Diameter.....	1 1/16	1 1/8	1 3/16	1 1/4	1 5/16	1 3/8	1 7/16	1 1/2	1 9/16	1 5/8	1 3/4	1 7/8	2	inch.
Full Length...	10 1/2	11	11	11 1/2	11 1/2	12	12	12 1/2	12 1/2	13	13 1/2	14	14	"
Flute, length...	2 3/4	2 3/4	2 3/4	3	3	3 1/4	3 1/4	3 1/2	3 1/2	3 3/4	4	4 1/4	4 1/4	"
Price, each....	\$3.40	3.60	3.85	4.05	4.30	4.50	4.75	5.00	5.20	5.40	5.85	6.35	6.90	

FLUTED CHUCKING REAMERS

No. 119



1/4 inch.
9
4.55

Diameter.....	1/4	5/16	3/8	7/16	1/2	9/16	5/8	11/16	3/4	13/16	7/8	15/16	1	inch.
Full Length...	6	6	7	7	8	8	9	9	9 1/2	9 1/2	10	10	10 1/2	"
Flute, length...	1 1/2	1 1/2	1	1	1 1/4	1 1/4	1 1/2	1 1/2	1 3/4	1 3/4	1 3/4	1 3/4	1 3/4	"
Price, each....	\$1.35	1.50	1.65	1.80	1.95	2.10	2.25	2.40	2.55	2.80	3.00	3.25	3.45	

Diameter.....	1 1/16	1 1/8	1 3/16	1 1/4	1 5/16	1 3/8	1 7/16	1 1/2	1 9/16	1 5/8	1 3/4	1 7/8	2	inch.
Full Length...	10 1/2	11	11	11 1/2	11 1/2	12	12	12 1/2	12 1/2	13	13 1/2	14	14	"
Flute, length...	1 1/2	1 1/2	1 1/2	1 3/4	1 3/4	2	2	2 1/4	2 1/4	2 1/2	2 1/2	2 3/4	2 3/4	"
Price, each....	\$3.70	3.90	4.10	4.35	4.60	4.80	5.00	5.25	5.50	5.70	6.35	6.90	7.50	

The above Reamers are finished .005 of an inch under Standard, and are slightly tapered on end of Flute.

MORSE ADJUSTABLE REAMERS

No. 120 E



Diameter.....	$\frac{3}{4}$	$\frac{7}{16}$	$\frac{3}{8}$	$\frac{15}{16}$	1	$\frac{1}{16}$	$\frac{1}{8}$	$\frac{1}{4}$	$\frac{1}{2}$	$\frac{5}{8}$	$\frac{3}{4}$	$\frac{7}{8}$	$\frac{15}{16}$	$\frac{1}{2}$ inch.
Price, each....	\$6.00	7.50	7.95	8.40	8.85	9.35	9.75	10.20	10.65	11.10	11.70	12.30	12.90	

Adjustable Reamers are not furnished smaller than $\frac{3}{4}$ inches diameter.

SHELL REAMERS

No. 117



Diameter.....	$\frac{1}{4}$	$\frac{5}{16}$	$\frac{3}{8}$	$\frac{7}{16}$	$\frac{1}{2}$	$\frac{9}{16}$	$\frac{5}{8}$	$\frac{11}{16}$	$\frac{3}{4}$	$\frac{13}{16}$	$\frac{7}{8}$	$\frac{15}{16}$	1 inch.
Length.....	$1\frac{1}{2}$	$1\frac{1}{2}$	$1\frac{1}{2}$	$1\frac{1}{2}$	2	2	$2\frac{1}{2}$	$2\frac{1}{2}$	$2\frac{1}{2}$	$2\frac{1}{2}$	$2\frac{1}{2}$	$2\frac{1}{2}$	$2\frac{1}{2}$
Diam. of Hole	$\frac{1}{8}$	$\frac{3}{16}$	$\frac{1}{4}$	$\frac{5}{16}$	$\frac{3}{8}$	$\frac{1}{2}$	$\frac{5}{8}$	$\frac{3}{4}$	$\frac{7}{8}$	$\frac{15}{16}$	$\frac{1}{2}$	$\frac{3}{4}$	$\frac{1}{2}$
Price, each....	\$1.05	1.05	1.80	1.95	2.10	2.25	2.40	2.40	2.40	2.40	2.55	2.55	2.70

Diameter....	$\frac{1}{16}$	$\frac{1}{8}$	$\frac{1}{4}$	$\frac{1}{2}$	$\frac{3}{4}$	$\frac{1}{2}$	$\frac{1}{4}$	$\frac{1}{8}$	$\frac{1}{16}$	$\frac{1}{8}$	$\frac{1}{4}$	$\frac{1}{2}$	$\frac{3}{4}$	1 inch.
Length.....	$2\frac{1}{2}$	$2\frac{1}{2}$	$2\frac{1}{2}$	$2\frac{1}{2}$	$2\frac{1}{2}$	$2\frac{1}{2}$	$2\frac{1}{2}$	$2\frac{1}{2}$	$2\frac{1}{2}$	$2\frac{1}{2}$	$2\frac{1}{2}$	$2\frac{1}{2}$	$2\frac{1}{2}$	$2\frac{1}{2}$
Diam. of Hole	$\frac{1}{8}$	$\frac{3}{16}$	$\frac{1}{4}$	$\frac{5}{16}$	$\frac{3}{8}$	$\frac{1}{2}$	$\frac{5}{8}$	$\frac{3}{4}$	$\frac{7}{8}$	$\frac{15}{16}$	$\frac{1}{2}$	$\frac{3}{4}$	$\frac{1}{2}$	$\frac{3}{4}$
Price, each....	\$2.70	2.85	3.00	3.30	3.60	3.90	4.20	4.50	4.80	5.25	5.70	6.15	6.70	

Diameter.....	$\frac{1}{8}$	$\frac{1}{4}$	$\frac{1}{2}$	$\frac{3}{4}$	$\frac{1}{2}$	$\frac{1}{4}$	$\frac{1}{8}$	$\frac{1}{16}$	$\frac{1}{8}$	$\frac{1}{4}$	$\frac{1}{2}$	$\frac{3}{4}$	1 inch.
Length.....	$3\frac{1}{2}$	$3\frac{1}{2}$	$3\frac{1}{2}$	$3\frac{1}{2}$	$3\frac{1}{2}$	$3\frac{1}{2}$	$3\frac{1}{2}$	$3\frac{1}{2}$	$3\frac{1}{2}$	$3\frac{1}{2}$	$3\frac{1}{2}$	$3\frac{1}{2}$	$3\frac{1}{2}$
Diam. of Hole	1	1	1	1	1	1	1	1	1	1	1	1	1
Price, each....	\$7.05	7.50	7.80	8.10	8.40	8.70	9.00	9.60	10.20	11.00	12.00	13.20	14.40

Shell Reamers, any Length or Diameter, made to Order.



MILLING OR SLOTTING CUTTERS WITH TEETH STRAIGHT OR SPIRAL

No. 126



Width of Face.....	$\frac{1}{8}$	$\frac{3}{16}$	$\frac{1}{4}$	$\frac{5}{16}$	$\frac{3}{8}$	$\frac{7}{16}$	$\frac{1}{2}$	$\frac{5}{8}$	$\frac{3}{4}$	1	$1\frac{1}{4}$	$1\frac{1}{2}$	$1\frac{3}{4}$	2	$2\frac{1}{2}$	3	inch.	
Diam. of Cutter....	$2\frac{1}{2}$	$2\frac{1}{2}$	$2\frac{1}{2}$	$2\frac{1}{2}$	$2\frac{1}{2}$	$2\frac{1}{2}$	$2\frac{1}{2}$	$2\frac{1}{2}$	$2\frac{1}{2}$	$2\frac{1}{2}$	$2\frac{1}{2}$	$2\frac{1}{2}$	$2\frac{1}{2}$	$2\frac{1}{2}$	$2\frac{1}{2}$	$2\frac{1}{2}$	$2\frac{1}{2}$	
Price, each.....	\$1.82	1.82	1.93	2.10	2.25	2.52	2.66	2.94	3.22	3.92	4.20	4.35	4.75	5.18	5.75	6.30		

The above sizes have Holes 1 in. diameter, Cutters of 1 in. face and larger have spiral teeth, unless otherwise ordered. In ordering carefully state diameter of Cutter and size of Hole desired.

METAL SLITTING SAWS

No. 132

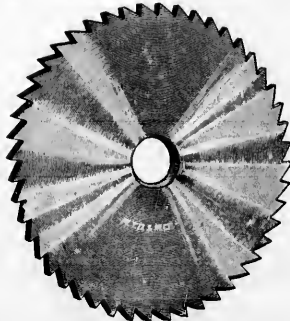

$2\frac{1}{2}$ in. Diameter,	$\frac{1}{8}$ in. Hole,	$\frac{1}{8}$ or $\frac{3}{16}$ in. Face.....	each	\$1.40
$2\frac{3}{4}$ "	"	$\frac{1}{8}$ or $\frac{3}{16}$ "	"	1.25
3 "	1 "	$\frac{3}{16}$ or $\frac{1}{4}$ "	"	1.75
3 "	1 "	$\frac{1}{8}$ or $\frac{3}{16}$ "	"	1.40
4 "	1 "	$\frac{3}{16}$ or $\frac{1}{4}$ "	"	2.00
4 "	1 "	$\frac{1}{8}$ or $\frac{3}{16}$ "	"	1.70

SCREW SLOTTING CUTTERS

No. 131

$1\frac{1}{2}$ in. Diameter,	.006 to .020 in. Thick,	$\frac{1}{8}$ or $\frac{3}{16}$ in. Hole.....	each	\$0.15
$2\frac{1}{2}$ "	.008 " .032 "	$\frac{3}{16}$ " "	"	0.20
$2\frac{3}{4}$ "	.006 " .057 "	$\frac{1}{4}$ " "	"	0.20

THE WILEY & RUSSELL MFG. CO'S

LIGHTNING TAPER REAMERS FOR BIT BRACE USE

No. 460



The sizes are arranged to follow each other from the smallest to the largest, so that with a set of these useful tools any size from $\frac{1}{8}$ to $1\frac{1}{2}$ inch may be accurately made. Each Reamer leaves a round, true cut hole.

Sizes	$\frac{1}{8}$	$\frac{3}{16}$	$\frac{1}{4}$	$\frac{5}{16}$	$\frac{3}{8}$	$\frac{7}{16}$	$\frac{1}{2}$	$\frac{9}{16}$	$\frac{5}{8}$	$1\frac{1}{16}$
Price, each	\$0.08	0.75	0.73	0.80	1.05	1.20	1.35	1.58		
Sizes	$\frac{3}{4}$	$1\frac{1}{16}$	$\frac{7}{8}$	$1\frac{1}{16}$	1	1$\frac{1}{8}$	1$\frac{1}{4}$			
Price, each	\$1.80	2.10	2.40	2.75	3.00	3.38	3.00			

BUTTERFIELD & CO'S TAPER REAMERS FOR BIT BRACE USE

Diameter..	$\frac{1}{4}$	$\frac{5}{16}$	$\frac{3}{8}$	$\frac{7}{16}$	$\frac{1}{2}$	$\frac{9}{16}$	$\frac{5}{8}$	$\frac{3}{4}$
Price, each	\$0.27	0.35	0.40	0.47	0.55	0.68	0.82	1.08

LIGHTNING TAPER REAMERS

With Shanks $\frac{1}{2}$ inch in diameter.

No. 470



Sizes	$\frac{1}{4}$	$\frac{5}{16}$	$\frac{3}{8}$	$\frac{7}{16}$	$\frac{1}{2}$	$\frac{9}{16}$	$\frac{5}{8}$	$1\frac{1}{16}$
Price, each	\$0.83	0.90	0.98	1.05	1.13	1.28	1.50	1.80
Sizes	$\frac{3}{4}$	$1\frac{1}{16}$	$\frac{7}{8}$	$1\frac{1}{16}$	1	1$\frac{1}{8}$	1$\frac{1}{4}$	
Price, each	\$2.10	2.40	2.70	3.00	3.38	3.90	4.50	

NEW CENTRE REAMER



Accurately made of the best steel, and of the most approved form.

No. 530— $\frac{1}{4}$ in. Shank, cuts $\frac{3}{8}$	each	\$0.38
" 531— $\frac{3}{8}$ " " " " $\frac{1}{2}$	"	0.45
" 532— $\frac{1}{2}$ " " " " $\frac{3}{4}$	"	0.90

LIGHTNING COUNTERSINKS

Round Shanks, $\frac{1}{2}$ and $\frac{3}{4}$ inch in diameter.



60 or 80 Degrees for Bolt or Screw Heads.

No. 500—Regular size, $\frac{3}{8}$ in. diam., $\frac{3}{8}$ in. cut. each \$0.75

No. 510—Large size, $\frac{1}{2}$ in. diam., $\frac{3}{8}$ in. cut. " 1.13

Give style of Shank and Degrees wanted.

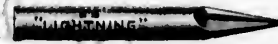

No. 520—25 Degrees for Sleigh Shank Bolts.

Bit Stock or $\frac{1}{2}$ inch Shank
 each | \$0.75 |

Give style of Shank wanted

LIGHTNING COUNTERSINK AND DRILL COMBINED.

No. 540



Can furnish these for using Straight Fluted Drills or Twist Drills, as may be preferred.

Each tool carries only one size of drill. Supplied with shanks $\frac{1}{2}$ in. diameter, for sizes $\frac{1}{8}$ to $\frac{3}{16}$;—with shanks $\frac{3}{4}$ in. diameter for sizes $\frac{1}{4}$ to $\frac{1}{2}$ in.

Price of Tools, without Drills	each	\$2.25
Extra Countersinking Cutters	"	0.30

LIGHTNING HOLDERS

No. 581



Chucks or Holders, for use in the bit brace, to take drills and other tools having round shanks, $\frac{1}{2}$ inch or $\frac{3}{4}$ inch in diameter. We can also supply these holders with $\frac{1}{2}$ inch and $\frac{3}{4}$ inch round shanks, instead of brace shanks. Price..... each \$1.13

THE WILEY & RUSSELL MFG. CO'S

TIRE MEASURING WHEELS

DROP FORGED

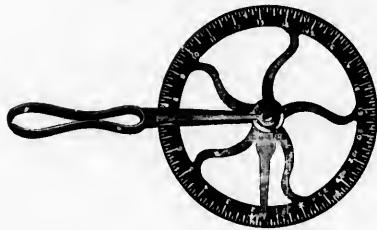

No. 606—Graduatedeach \$2.25

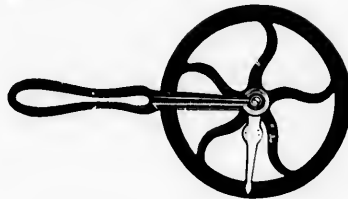

No. 607—Plain.....each \$1.88

TIRE BOLT HOLDER

No. 603



No. 603—Tire Bolt Holder.....each \$1.15

STEARN'S TIRE BOLT HOLDER

WITH STEEL SCREW, HARDENED POINT

Each..... \$0.90

HOLDERS FOR BIT BRACE AND MACHINE USE

No. 278



Showing Guide ahead.

No. 279



Showing face of Die ahead.

No. 278—Elastic Holder with Shank for use in Bit Brace, or No. 279 with Round Shank $\frac{1}{2}$ in. diameter. For X Dies $\frac{3}{8}$ in. outside diameter, admitting thread 1 inch long. Price.....each \$0.75

No. 280—Elastic Holder for use in Bit Brace or with $\frac{1}{2}$ inch diameter shank. For No. O Dies, $\frac{7}{8}$ inch outside diameter admitting thread $1\frac{1}{8}$ inch longeach 1.15

No. 282—Elastic Holder for use in Bit Brace or with $\frac{1}{2}$ inch diameter Shank, to take Dies $1\frac{1}{8}$ in. outside diameter, admitting thread $2\frac{3}{8}$ inch long.each 1.15

No. 284—Elastic Holders for use in Bit Brace or with $\frac{1}{2}$ inch diameter Shank, to take Dies $2\frac{1}{8}$ inches outside diameter, admitting thread $3\frac{1}{8}$ inches longeach 2.25

When using Plate Dies in these Holders they should be held with guide side out, but unless wanted specially to hold Plate Dies we would recommend dies to cut from face, but made in other respects like Plate Dies.

THE LIGHTNING TAPS, DIES AND HOLDERS

FOR USE IN THE BIT BRACE
STYLE B

Making perfect threads at a single cut. Sizes, $\frac{1}{8}$ in. to $\frac{1}{4}$ inch.

No. 286



Size	$\frac{3}{16}$	$\frac{1}{4}$	$\frac{5}{16}$	$\frac{3}{8}$	$\frac{7}{16}$
Die, Tap and Holder complete	\$2.85	2.85	2.93	3.38	3.53
Die only	\$1.50	1.50	1.50	1.50	1.73

Holder separatelyeach \$1.08

Taps only, see page 18.

Will send above set $\frac{1}{2}$ oversize and threads, unless otherwise ordered.

THE WILEY & RUSSELL MFG. CO'S

"X" SCREW PLATE

(Adjustable Dies, $\frac{1}{8}$ inch diameter.)
(Without Guides.)



- No. 350—Case containing Stock, Tap Wrench (fitted in stock) and 5 sizes of Taps and Diesper case \$6.00
- No. 352—Case containing Stock, Tap, Wrench (fitted in stock) and 7 sizes of Taps and Diesper case 8.90
- No. 354—Case containing Stock Tap Wrench (fitted in stock) and 10 sizes of Taps and Diesper case 11.65
- No. 358—Case containing Stock, Tap Wrench (fitted in stock) and 15 sizes of Taps and Diesper case 17.05



Form of Tap furnished with all of our "X," "X Full-Mounted" and No. C sets. For price see page 18.

Prices of Single Parts of "X" Sets.

Stock, $\frac{5}{16}$ inches long.....	each	\$0.60
Dies (regular sizes).....	"	0.60
Taps. See page 18.		
Tap Wrench (fitting in Stock).....	each	0.60
Cases, separate, 5 sizes.....	"	0.55
" " 7 ".....	"	0.65
" " 10 ".....	"	0.65
" " 15 ".....	"	1.00

"X FULL-MOUNTED" SCREW PLATE

(A Stock with Each Die.)
(Adjustable Dies, $\frac{1}{8}$ inch diameter.)



- No. 374—Case containing Tap Wrench and 5 sizes of Stocks, Dies and Tapsper case \$9.38
- No. 376—Case containing Tap Wrench and 7 sizes of Stocks, Dies and Tapsper case 12.38
- No. 378—Case containing Tap Wrench and 10 sizes of Stocks, Dies and Tapsper case 17.25
- No. 380—Case containing Tap Wrench and 12 sizes of Stocks, Dies and Tapsper case 20.25



Stock furnished with "X Full-Mounted" Sets.

These are always ready without the trouble and delay of fitting up. Several sizes may be in use at the same time. Each Stock has an accurate guide for its Die.

Prices of Single Parts of "X Full-Mounted" Sets.

Stocks (without Dies).....	each	\$0.60
Dies (regular sizes).....	"	0.60
Taps. See page 18.		
Tap Wrench, including Stock, complete.....	each	1.20
Cases, separate, 5 sizes.....	"	0.55
" " 7 ".....	"	0.65
" " 10 ".....	"	0.65
" " 12 ".....	"	0.85

REGULAR SIZES OF DIES AND TAPS CARRIED IN STOCK FOR ABOVE SETS FOR BICYCLE WORK IN THREADING SPOKES AND NIPPLES.

Wire Gauge Sizes—Nos. 11⁵⁰, 12⁵⁰, 13⁵⁰, 14⁵⁰, 15⁵⁰, 16⁵⁰, 17⁵⁰.

Machine Screw Sizes—Nos. 2⁵⁰, 3⁴⁸, 4⁴⁰, 6³², 8³², 10²⁴, 12²⁴, 14²⁰, 14²⁴, 16¹⁸, 16¹⁸, 18²⁰, 18¹⁸, 18²⁰, 20¹⁶, 24¹⁰.

Fractional Sizes—Nos. $\frac{1}{16}$ ⁴⁰, $\frac{5}{16}$ ⁶⁰, $\frac{3}{16}$ ⁴⁸, $\frac{7}{16}$ ⁴⁴, $\frac{1}{8}$ ⁴⁰, $\frac{1}{4}$ ⁴⁰, $\frac{5}{32}$ ³², $\frac{11}{64}$ ³⁰, $\frac{8}{16}$ ²⁴, $\frac{3}{16}$ ³², $\frac{13}{64}$ ³², $\frac{7}{32}$ ²⁸, $\frac{15}{64}$ ²⁸, $\frac{1}{4}$ ²⁰, $\frac{1}{4}$ ²⁴, $\frac{17}{64}$ ²⁰, $\frac{9}{32}$ ²⁰.

THE WILEY & RUSSELL MFG. CO'S

BICYCLE SCREW PLATES

(Adjustable Dies with Guides.)

These sets are supplied with exact sizes, V Thread, and Taper Taps. Will substitute Plug Taps, if preferred.

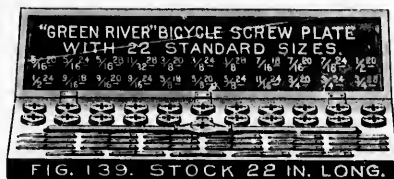

FIG. 139. STOCK 22 IN. LONG.

- No. **133**—Case containing Stock 10 inches long and 7 sizes of Taps, Dies and Guides, 1-4²⁴, 5-10²⁴, 5-10³², 3-8³², 3-8²⁴, 7-10²⁰, 7-10²⁴. Price, complete.....\$17.25
- No. **134**—Same as No. 133, except with Adjustable Tap Wrench No. 2..... 20.75
- No. **135**—Case containing Stock 22 inches long and 6 sizes of Taps, Dies and Guides, 5-10²⁴, 3-8²⁴, 7-10²⁴, 1-2²⁴, 5-8²⁴, 3-4²⁴. Price, complete..... 19.50
- No. **136**—Same as No. 135, except with Adjustable Tap Wrench No. 3..... 21.00
- No. **137**—Case containing Stock 22 inches long and 14 sizes of Taps, Dies and Guides, 5-10²⁴, 3-8²⁰, 3-8²⁴, 7-10²⁰, 7-10²⁴, 1-2²⁰, 1-2²⁴, 9-10²⁰, 9-10²⁴, 5-8²⁰, 5-8²⁴, 3-1²⁰, 3-4²⁴, 3-4²⁴. Price, complete..... 42.75
- No. **138**—Same as No. 137, except with Adjustable Tap Wrench No. 3..... 47.25
- No. **139**—Case containing Stock 22 inches long and 22 sizes of Taps, Dies and Guides, 5-10²⁴, 5-10³², 5-10²⁰, 11-32²⁴, 3-8²⁰, 3-8²⁴, 7-10²⁴, 7-10²⁰, 7-10²⁴, 1-2²⁰, 1-2²⁴, 9-10¹⁸, 9-10²⁴, 3-8²⁴, 5-8²⁰, 5-8²⁴, 11-10²⁴, 3-4²⁰, 3-4²⁴, 3-4²⁴. Price, complete..... 62.25
- No. **140**—Same as No. 139, except with Adjustable Tap Wrench No. 3..... 66.75
- Outside Diameter of Dies for No. 133, 1¹⁶/₈; Nos. 134 to 140, 2¹⁶/₈ inches.
- No. **141**—Case containing 18 sizes. Two Stocks and Taps, Dies and Guides, Birmingham ("Stubs") Wire Gauge sizes, Nos. 10⁵⁰, 15⁵⁰, 14⁵⁰, 13⁴⁸, 13⁵⁰, 12⁴⁸, 12⁵⁰, 12⁵⁰, 11⁵⁰, and Fractional sizes, 9-64⁴⁰, 5-32³⁰, 3-16²⁴, 7-32²⁴, 1-4²⁴, 5-16²⁴, 3-8²⁴, 7-16²⁴ and Tap Wrench fitting in small stock to take the 15 smallest taps. Price, complete..... 28.85
- Diameter of Dies in this set $\frac{1}{8}$ in., and under, is $\frac{1}{16}$ inch; $\frac{3}{16}$ in., and over, is $1\frac{1}{16}$ inches.
- No. **142**—As above, with Adjustable Tap Wrench..... 32.40



FIG. 143 STOCKS 6 IN. AND 22 IN. LONG.

- No. **143**—Case containing 21 sizes. Two Stocks and Taps, Dies and Guides, Birmingham ("Stubs") Wire Gauge sizes, Nos. 10⁵⁰, 15⁵⁰, 14⁵⁰, 13⁴⁸, 13⁵⁰, 12⁴⁸, 12⁵⁰, 12⁵⁰, 11⁵⁰ and Fractional sizes, 9-64⁴⁰, 5-32³⁰, 3-16²⁴, 7-32²⁴, 1-4²⁴, 5-16²⁴, 3-8²⁴, 7-10²⁴, 1-2²⁴, 5-8²⁴, 3-4²⁴ and Tap Wrench fitting in small stock to take the 15 smallest taps. Price, complete.....\$40.15
- Diameter of Dies in this set $\frac{1}{8}$ in., and under, is $\frac{1}{16}$ inch; $\frac{3}{16}$ in., and over, is $2\frac{1}{16}$ inches.
- No. **144**—As above, with Adjustable Tap Wrench. 44.65
- In sizes $\frac{1}{8}$ and larger in above sets we regularly send Taper Taps, but will substitute Plug Taps, if preferred.



FIG. 145 STOCKS 6 IN. AND 22 IN. LONG.

- No. **145**—Case containing 38 sizes. Two Stocks and Taps, Dies and Guides, Birmingham ("Stubs") Wire Gauge sizes, Nos. 10⁵⁰, 15⁵⁰, 14⁵⁰, 13⁴⁸, 13⁵⁰, 12⁴⁸, 12⁵⁰, 12⁵⁰, 11⁵⁰, and Fractional sizes 9-64⁴⁰, 5-32³⁰, 3-16²⁴, 7-32²⁴, 1-4²⁴, 9-32²⁴, 5-16²⁴, 5-16²⁴, 5-16²⁴, 11-32²⁴, 3-8²⁰, 3-8²⁴, 3-8²⁴, 7-10²⁴, 7-10²⁴, 1-2²⁰, 1-2²⁴, 9-10¹⁸, 9-10²⁴, 9-10²⁴, 5-8¹⁸, 5-8²⁰, 5-8²⁴, 11-10²⁴, 3-4²⁰, 3-4²⁴, 3-4²⁴, and Tap Wrench fitting in small stock to take the 16 smallest taps. Price, complete..... 81.00
- Diameter of Dies in this set $\frac{1}{8}$ in., and under, is $\frac{1}{16}$ inch; $\frac{3}{16}$ in., and over, is $2\frac{1}{16}$ inches.
- No. **146**—As above, with Adjustable Tap Wrench No. 3..... 88.50

Prices of Dies and Guides Singly.

For Sizes having Dies 1¹⁶/₈ and 2¹⁶/₈ inches outside Diameter.

Sizes	$\frac{1}{4}$	$\frac{3}{16}$	$\frac{1}{2}$	$\frac{5}{8}$	$\frac{3}{4}$	$\frac{1}{2}$	$\frac{9}{16}$	$\frac{5}{8}$	$\frac{1}{4}$	$\frac{3}{4}$ inch.
1 ¹⁶ / ₈ Outside Diameter, each	\$1.50	1.50	1.50	1.50	1.50	2.25	2.25	2.40	2.03	3.00
2 ¹⁶ / ₈ " " "	\$1.88	1.88	1.88	1.88	2.25	2.25	2.40	2.03	2.85	3.00

Guides for 1¹⁶/₈ Dies, each \$0.30; for 2¹⁶/₈ Dies, each \$0.38.

Price of Taps, see Machinists' Hand Taps, page 19; Stocks, see page 12; Dies and Guides, $\frac{1}{8}$ diameter, see page 9.

THE WILEY & RUSSELL MFG. CO'S

No. 0 LIGHTNING SCREW PLATE

(Adjustable Dies, $\frac{1}{4}$ inch Diameter.
Case Hardened Guides.)

EXPLANATION OF DIE

Used in "Lightning" Plates Nos. 0 and A.



The cut shows a Die and Guide complete; also a Die taken apart to show the mechanism. The cup-headed screw on the right holds the halves together as a hinge, while the size is regulated by the wedge-shaped screw on the left, the Die being clamped in the Elastic Stock. It is readily adjusted.

$\frac{1}{4}$ inch diameter, Case-hardened Guides.



No. 150—Case containing Stock, Tap Wrench (fitted in Stock) and 5 sizes Taps, Dies and Guides. per case \$ 8.25

No. 152—Case containing Stock, Tap Wrench (fitted in Stock) and 7 sizes Taps, Dies and Guides. per case 10.50

No. 154—Case containing Stock, Tap Wrench (fitted in Stock) and 10 sizes Taps, Dies and Guides. per case 14.65

No. 158—Case containing Stock, Tap Wrench (fitted in Stock) and 15 sizes Taps, Dies and Guides. per case 20.65

Regular sizes of Dies and Taps carried in stock for above sets.

Bicycle Sizes for Threading Spokes and Nipples.

Wire Gauge Sizes, Nos. 11⁰⁰, 12⁰⁰, 12⁵⁰, 13⁰⁰, 13⁵⁰, 14⁰⁰, 15⁰⁰, 16⁰⁰, 17⁰⁰.

Machine Screw Sizes, Nos. 2⁵⁰, 3⁴⁸, 4⁵⁰, 6⁵⁰, 8⁵⁰, 10⁵⁰, 12⁵⁰, 14⁵⁰, 16⁵⁰, 18⁵⁰.

Fractional Sizes, $\frac{5}{16}$ ⁰⁰, $\frac{3}{32}$ ⁴⁸, $\frac{7}{64}$ ⁴¹, $\frac{1}{8}$ ⁴⁰, $\frac{9}{64}$ ⁴⁰, $\frac{5}{32}$ ³⁰, $\frac{11}{64}$ ⁴⁰, $\frac{3}{16}$ ³², $\frac{13}{64}$ ³², $\frac{7}{32}$ ²¹, $\frac{15}{64}$ ²⁰, $\frac{1}{4}$ ²⁰, $\frac{17}{64}$ ²⁰, $\frac{9}{32}$ ²⁰.

Prices of Single Parts of No. "O" Sets.

Die, Guide and Tap (regular sizes)	each	\$1.50
Dies, regular sizes	"	0.00
Guides	"	0.25
Taps, regular sizes. See page 18.		
Tap Wrench (fitting in stock)	"	0.75
Stock	"	1.15

LIGHTNING SCREW PLATES

With Standard Threads.
(Adjustable Dies with Guides.)

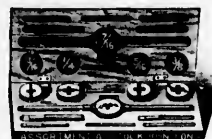

No. 180—Set A— $\frac{1}{8}$ to $\frac{1}{4}$ inch; Stock 10 inches long and 5 sizes Taps, Dies and Guides, $\frac{1}{8}$, $\frac{1}{16}$, $\frac{3}{16}$, $\frac{7}{16}$ inch. per case \$12.00

Diameter of Dies in this set $1\frac{1}{16}$ inches.

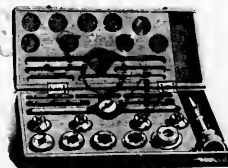

No. 186—Set A 1— $\frac{1}{8}$ to $\frac{1}{4}$ inch. Stock 10 inches long, Bit Brace Holder and Nut Wrenches. 5 sizes Taps, Dies, Guides and Nut Wrenches, $\frac{1}{8}$, $\frac{1}{16}$, $\frac{3}{16}$, $\frac{7}{16}$ inches. . . per case 15.00

Diameter of Dies in this set, $1\frac{1}{16}$ inch.

Prices of Single Parts for Sets A and A 1.

Dies, all regular sizes	each	1.50
Guides	"	0.30
Stocks (10 inches long)	"	2.25
Holders for use in bit brace.	"	1.15
Holders for use in lathe	"	1.15
Nut Wrenches to fit in stock or holders.	"	0.30
Taps. See Hand Taps, page 10.		



No. 190—Set AA— $\frac{1}{8}$ to $\frac{1}{4}$ inch. Stock 18 inches long. 6 sizes, $\frac{1}{8}$, $\frac{1}{16}$, $\frac{3}{16}$, $\frac{7}{16}$, $\frac{1}{2}$ inch Taps, Dies and Collets per case 20.25

Diameter of Collets in this set, $2\frac{1}{8}$ inches.



No. 192—Set B— $\frac{1}{4}$ to $\frac{3}{4}$ inch. Stock 23 inches long. 7 sizes, $\frac{1}{4}$, $\frac{1}{2}$, $\frac{3}{4}$, $\frac{1}{2}$, $\frac{3}{4}$, $\frac{1}{2}$, $\frac{3}{4}$ inch Taps, Dies and Collets. Price, complete. 25.00

Diameter of Collets in this set, $2\frac{1}{8}$ inches.

No. 193—Set B—As above, with Adjustable Tap Wrench No. 3 30.40

Will send above sets $\frac{1}{2}$ oversize, V thread, unless otherwise ordered.

THE WILEY & RUSSELL MFG. CO'S LIGHTNING SCREW PLATES



No. 194—Set C— $\frac{1}{4}$ to 1 inch. Stock 20 in. long, 5 sizes, $\frac{1}{8}$, $\frac{3}{16}$, $\frac{1}{4}$, $\frac{5}{16}$, $\frac{3}{8}$, 1 inch Taps, Dies and Collets. Price, complete \$27.75
Diameter of Collets in this set, $2\frac{1}{2}$ inches.

No. 195—Set C— $\frac{1}{4}$ to 1 inch, as above, with Adjustable Tap Wrench No. 4..... 33.75



No. 198—Set C— $\frac{1}{4}$ to 1 inch. Stock 20 inches long. 9 sizes, $\frac{1}{8}$, $\frac{1}{16}$, $\frac{3}{16}$, $\frac{1}{4}$, $\frac{5}{16}$, $\frac{3}{8}$, $\frac{1}{2}$, 1 in. Taps, Dies and Collets. Price, complete 38.25
Diameter of Collets in this set, $2\frac{3}{4}$ inches.

No. 199—Set C— $\frac{1}{4}$ to 1 inch, as above, with Adjustable Tap Wrenches Nos. 2 and 4..... 47.80



No. 200—Set D— $\frac{1}{4}$ to $1\frac{1}{2}$ inch. Stock 53 inches long. 6 sizes, $\frac{1}{4}$, 1, $1\frac{1}{4}$, $1\frac{1}{2}$, $1\frac{3}{4}$, $1\frac{1}{2}$ inch Taps, Dies and Collets. Price, complete 67.50
Diameter of Collets in this set, $4\frac{1}{2}$ inches.

For price of Adjustable Tap Wrench, size 5, see page 17.



No. 203—Set L— $\frac{1}{4}$ to 1 inch. Two Stocks, one 18 inches long, and one 20 inches long. 9 sizes, $\frac{1}{8}$, $\frac{1}{16}$, $\frac{3}{16}$, $\frac{1}{4}$, $\frac{5}{16}$, $\frac{3}{8}$, $\frac{1}{2}$, 1 inch Taps, Dies and Collets. Price, complete..... \$41.25
Diameter of Collets in this set, $\frac{7}{8}$ in. and under, $2\frac{1}{8}$ inches; $\frac{1}{2}$ in. and over, $2\frac{1}{4}$ inches.

For prices of Adjustable Tap Wrenches, sizes 2 and 4, see page 17.

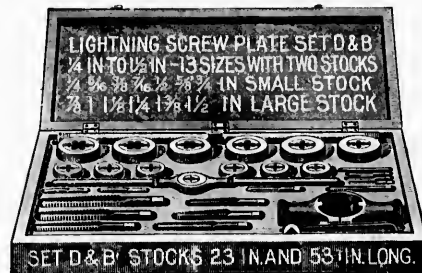

No. 205—Set D & B— $\frac{1}{4}$ to $1\frac{1}{2}$ inch. Two Stocks, one 23 inches long, and one 53 inches long. 13 sizes, $\frac{1}{8}$, $\frac{1}{16}$, $\frac{3}{16}$, $\frac{1}{4}$, $\frac{5}{16}$, $\frac{3}{8}$, $\frac{1}{2}$, 1, $1\frac{1}{4}$, $1\frac{1}{2}$, $1\frac{3}{4}$ inch Taps, Dies and Collets. Price, complete 91.50
Diameter of Collets in this set, $\frac{3}{4}$ in., and under, $2\frac{3}{4}$ inches; $\frac{1}{2}$ in., and over, $4\frac{1}{2}$ inches.

For prices of Adjustable Tap Wrenches, sizes 3 and 5, see page 17.

THE GREEN RIVER SCREW PLATE



No. 100—Set No. 1— $\frac{1}{16}$ to $\frac{1}{8}$ inch. Stock 10 inches long, with both Stock and Brace Holder for Dies. 5 sizes, $\frac{1}{16}$, $\frac{1}{8}$, $\frac{3}{16}$, $\frac{1}{4}$, $\frac{5}{16}$ inch Taps, Dies and Guides. Complete, in case..... \$12.25
Diameter of Dies in this set, $1\frac{1}{8}$ inches.

No. 122—Set. No. 1, as above, with Adjustable Tap Wrench No. 2..... 15.00



No. 101—Set No. $1\frac{1}{4}$ — $\frac{3}{8}$ to $\frac{1}{2}$ in. Stock 18 inches long. 6 sizes, $\frac{1}{8}$, $\frac{1}{4}$, $\frac{3}{8}$, $\frac{1}{2}$, $\frac{5}{8}$, $\frac{3}{4}$ inch Taps, Dies and Guides. Complete, in case \$14.10
Diameter of Dies in this set, $2\frac{1}{8}$ inches.

No. 102—Set No. $1\frac{1}{4}$, as above, with Adjustable Tap Wrench No. 2..... 17.85

Will send above sets $\frac{1}{2}$ oversize, V thread, unless otherwise ordered.

THE WILEY & RUSSELL MFG. CO'S

GREEN RIVER SCREW PLATES



No. 103—Set No. 1 $\frac{1}{2}$ — $\frac{1}{4}$ to $\frac{3}{8}$ inch. Stock 22 inches long. 7 sizes, $\frac{1}{4}$, $\frac{7}{16}$, $\frac{1}{2}$, $\frac{9}{16}$, $\frac{5}{8}$, $\frac{11}{16}$, $\frac{3}{4}$ inch. Taps, Dies and Guides. Complete, in case \$16.65
Diameter of Dies in this set, 2 $\frac{1}{16}$ inches.

No. 104—Set No. 1 $\frac{1}{2}$, as above, with Adjustable Tap Wrench, No. 3. Complete, in case ... 21.40



No. 107—Set No. 3— $\frac{1}{2}$ to 1 inch. Stock 20 inches long. 5 sizes, $\frac{1}{2}$, $\frac{5}{8}$, $\frac{3}{4}$, $\frac{7}{8}$, 1 inch Taps, Dies and Guides. Complete, in case 21.25
Diameter of Dies in this set, 2 $\frac{1}{8}$ inches.

No. 108—Set No. 3, as above, with Adjustable Tap Wrench, No. 4. Complete, in case 23.15



No. 111—Set No. 5— $\frac{1}{4}$ to 1 inch. Stock 20 inches long. 9 sizes, $\frac{1}{8}$, $\frac{1}{16}$, $\frac{3}{16}$, $\frac{1}{4}$, $\frac{5}{16}$, $\frac{3}{8}$, $\frac{7}{16}$, $\frac{1}{2}$, 1 inch Taps, Dies and Guides. Complete, in case. 29.40
Diameter of Dies in this set, 2 $\frac{1}{8}$ inches.

No. 112—Set No. 5, as above, with Adjustable Tap Wrenches, Nos. 2 and 4. Complete, in case. 39.45

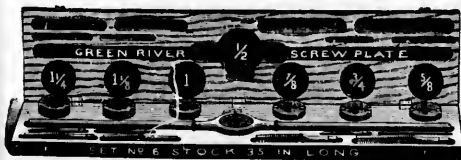

No. 113—Set No. 8— $\frac{1}{4}$ to 1 $\frac{1}{2}$ inch. Stock 35 inches long. 7 sizes, $\frac{1}{4}$, $\frac{5}{8}$, $\frac{3}{4}$, $\frac{7}{8}$, 1, 1 $\frac{1}{4}$, 1 $\frac{1}{2}$ inch Taps, Dies and Guides. Complete, in case \$33.30
Diameter of Dies in this set, 2 $\frac{1}{8}$ inches.

For prices of Adjustable Tap Wrenches, sizes Nos. 3 and 5, see page 17.



No. 115—Set No. 8— $\frac{1}{4}$ to 1 $\frac{1}{2}$ inch. Stock 35 inches long. 11 sizes, $\frac{1}{4}$, $\frac{5}{8}$, $\frac{3}{4}$, $\frac{7}{8}$, $\frac{1}{2}$, $\frac{3}{4}$, $\frac{7}{8}$, 1, 1 $\frac{1}{4}$, 1 $\frac{1}{2}$ inch Taps, Dies and Guides. Complete, in case \$43.50

Diameter of Dies in this set, 2 $\frac{1}{8}$ inches.

For prices of Adjustable Tap Wrenches, sizes Nos. 3 and 5, see page 17.



No. 119—Set No. 16— $\frac{1}{4}$ to 1 $\frac{1}{2}$ inch, 11 sizes. Two Stocks, one 22 inches long and one 35 inches long, and $\frac{1}{8}$, $\frac{1}{16}$, $\frac{3}{16}$, $\frac{1}{4}$, $\frac{5}{16}$, $\frac{3}{8}$, $\frac{7}{16}$, $\frac{1}{2}$, 1, 1 $\frac{1}{4}$, 1 $\frac{1}{2}$ inch Taps, Dies and Guides. Complete, in case 46.15

Diameter of Dies in this set, $\frac{7}{16}$ in. and under, 2 $\frac{3}{16}$ inches; $\frac{1}{2}$ in. and over, 2 $\frac{1}{8}$ inches.



No. 120—Set No. 25— $\frac{1}{4}$ to 1 $\frac{1}{2}$ inch, 13 sizes. Two Stocks, one 22 inches long and one 53 inches long, and $\frac{1}{8}$, $\frac{1}{16}$, $\frac{3}{16}$, $\frac{1}{4}$, $\frac{5}{16}$, $\frac{3}{8}$, $\frac{7}{16}$, $\frac{1}{2}$, $\frac{3}{4}$, 1, 1 $\frac{1}{4}$, 1 $\frac{1}{2}$, 1 $\frac{3}{4}$ inch Taps, Dies and Guides. Complete, in case 67.85

Diameter of Dies in this set $\frac{7}{16}$ inch and under, 2 $\frac{3}{16}$ inches; $\frac{1}{2}$ in. and over, 3 $\frac{1}{16}$ inches.

For prices of Adjustable Tap Wrenches, sizes 3 and 5, see page 17.

Will send above sets $\frac{1}{16}$ oversize, V thread, unless otherwise ordered.

THE WILEY & RUSSELL MFG. CO'S

THE NEW FULL-MOUNTED LIGHTNING SCREW PLATES

A Stock to each Die.



- No. 216— $\frac{1}{8}$ to $\frac{1}{2}$ inch. A Stock to each Die. 6 sizes, $\frac{1}{8}$, $\frac{1}{4}$, $\frac{3}{8}$, $\frac{1}{2}$, $\frac{3}{4}$, 1 inch Taps, Dies and Stocks. Complete, in case \$18.00
- No. 217—Same as No. 216, but with Adjustable Tap Wrench No. 2. Complete, in case..... 21.55



- No. 218— $\frac{1}{4}$ to $\frac{3}{4}$ inch. A Stock to each Die. 5 sizes, $\frac{1}{4}$, $\frac{3}{8}$, $\frac{1}{2}$, $\frac{3}{4}$ inch Taps, Dies and Stocks. Complete, in case..... 18.75
- No. 219—Same as No. 218, but with Adjustable Tap Wrench No. 3. Complete, in case.... 23.25
- No. 222—Set BB— $\frac{1}{4}$ to $\frac{3}{4}$ inch. A Stock to each Die. 7 sizes, $\frac{1}{4}$, $\frac{3}{8}$, $\frac{1}{2}$, $\frac{3}{4}$, 1 inch Taps, Dies and Stocks. Complete, in case 24.00
- No. 224—Set CE— $\frac{1}{2}$ to 1 inch. A Stock to each Die. 5 sizes, $\frac{1}{2}$, $\frac{3}{4}$, 1 inch Taps, Dies and Stocks. Complete, in case 27.75
- No. 226—Set CC— $\frac{3}{4}$ to 1 inch. A Stock to each Die. 7 sizes, $\frac{3}{4}$, 1 inch Taps, Dies and Stocks. Complete, in case..... 33.00
- No. 228—Set CCC— $\frac{1}{2}$ to 1 inch. A Stock to each Die. 9 sizes, $\frac{1}{2}$, $\frac{3}{4}$, 1 inch Taps, Dies and Stocks. Complete, in case 38.25

PUMPMAKERS' LIGHTNING DIES AND STOCKS

Double Stock with $\frac{3}{8}$ and $\frac{7}{16}$ inch Dies.



- No. 900—Double Stock, with one Die each, $\frac{3}{8}$ " and $\frac{7}{16}$ ". Complete \$4.50

Prices of Dies.

- Size $\frac{3}{8}$ " for Double Stock 1.50
" $\frac{7}{16}$ " " " 1.75

In ordering Dies separately be sure to state whether wanted for Single or Double Stock.

Will send above sets $\frac{1}{2}$ oversize, V thread, unless otherwise ordered.

STOCKS FOR LIGHTNING AND GREEN RIVER SCREW PLATES



The above cut shows Patent Elastic Stock used with all of our Screw Plates, excepting the Full-Mounted, Pipe and X Plates.

Prices of Stocks.

Length 10 in., for $1\frac{1}{8}$ in. diameter Dies	each	\$2.25
" 18 " $2\frac{1}{8}$ " " " " "	"	3.00
" 22 " $2\frac{3}{8}$ " " " " "	"	3.00
" 23 " $2\frac{1}{2}$ " " " " "	"	3.00
" 29 " $2\frac{3}{4}$ " " " " "	"	3.00
" 35 " $2\frac{7}{8}$ " " " " "	"	6.00
" 53 " $3\frac{1}{8}$ " " " " "	"	9.00



- No. 176—No. 0 Stock, length 6 inches, for $\frac{1}{4}$ in diameter Dies.....each 1.15



- No. 177—No. 0 Stock with one handle. For use in threading or sizing rods or wire in lathe. Takes any of the $\frac{1}{4}$ inch diameter Dies in No. 0 Sets. Price, without Die 1.15



- No. 178—No. X Stock, length $5\frac{1}{2}$ inches, for $\frac{1}{4}$ in. diameter Dies.....each 0.90

NEW FULL-MOUNTED STOCKS



Size for	$\frac{1}{4}$	$\frac{3}{8}$	$\frac{1}{2}$	$\frac{3}{4}$	1 inch.
Without Die .	\$0.75	0.75	0.85	0.90	1.05
Size for	$\frac{5}{8}$	$\frac{3}{4}$	$\frac{7}{8}$	1	$1\frac{1}{4}$ inch.
Without Die .	\$1.30	1.35	1.65	1.90	2.65

THE WILEY & RUSSELL MFG. CO'S

LIGHTNING DIES

USED IN A, B AND C SETS

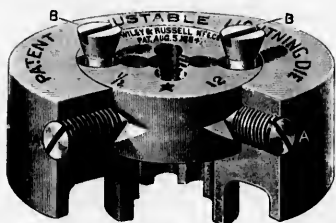

The Taper-Headed Screws, B B, regulate the size. Two Binding Screws, not shown in cut, are placed opposite the two shown, A A.

In adjusting the Die, the binding screws, A A, are first slackened, and the size required fixed by moving the taper-headed screws, B B, in or out; after which the binding screws, A A, are set very tight the last thing.

Prices of Dies and Collets for Lightning Screw Plates.

Size.....	3/16	1/4	5/16	3/8	7/16	1/2	inch.
Dies, each	\$1.50	1.50	1.50	1.75	1.95	2.25	
Size.....	7/16	5/8	3/4	7/8	1	inch.	
Dies, each	\$2.40	2.65	3.00	3.75	4.50		
Collets, each							75c.

Prices of Dies and Collets for Lightning Screw Plate D.

Size.....	7/8	1	1 1/8	1 1/4	1 1/2	1 3/4	inch.
Dies, each	\$3.75	4.50	5.25	6.00	6.75	7.50	
Collets, each							\$1.50

W. & R. SOLID ROUND BOLT DIES.

FOR MACHINE USE.



Size.	Diameter.	Price each.
1/4 in.	1 1/8 x 3/8 in.	\$1.50
5/16 "	1 1/8 x 3/8 "	1.50
3/8 "	1 1/8 x 3/8 "	1.50
7/16 "	1 1/8 x 3/8 "	1.50
1/2 "	1 1/8 x 3/8 "	2.25
5/8 "	1 1/8 x 3/8 "	2.65
3/4 "	2 1/8 x 1 1/8 "	3.00
7/8 "	2 1/8 x 1 1/8 "	3.75
1 "	2 1/8 x 1 1/8 "	4.50

GREEN RIVER DIES

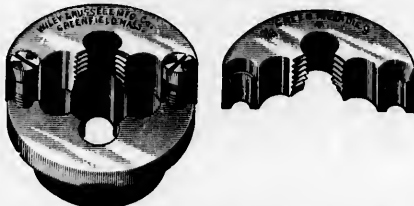

The cut above shows a "Green River" Die and Guide taken apart to show the mechanism. The cup-headed screw on the right holds the halves firmly together, acting as a hinge, while the size is regulated by the wedge-shaped (taper head) screw on the left, the whole being clamped in the elastic stock.

For cutting close up to a shoulder, use the face side of Die after starting the thread with the other side.

Prices of Dies and Guides for Green River Screw Plates.

Size.....	3/16	1/4	5/16	3/8	7/16	inch.
Dies, each	\$1.88	1.88	1.88	2.25	2.25	
Size.....	1/2	5/16	3/8	3/4	7/8	inch.
Dies, each	\$2.25	2.40	2.65	3.00	3.75	
Size.....	1	1 1/8	1 1/4	1 1/2	1 3/4	inch
Dies, each	\$4.50	5.25	6.00	6.75	7.00	
Guides, each						38c.

For Price of Plate Taps, see Hand Taps, page 10.

SOLID SQUARE BOLT DIES.

FOR SETS ON PAGE 15

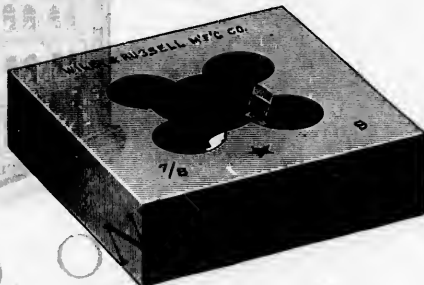

Size of Die.	Threads per in.	Size of Square.	Price each.	Size of Square.	Price each.
1/4 in.	20	1 in.	\$0.90	1 1/4 in.	\$1.25
5/16 "	18	1 " "	0.90	1 1/2 " "	1.25
3/8 "	16	1 " "	0.90	1 3/4 " "	1.25
7/16 "	14	1 " "	0.90	2 " "	1.25
1/2 "	12	1 1/4 " "	1.25	1 1/2 " "	1.35
9/16 "	12	1 1/4 " "	1.25	1 3/4 " "	1.35
5/8 "	11	1 1/2 " "	1.25	2 " "	1.35
3/4 "	10	1 3/4 " "	1.35	2 1/4 " "	2.00
7/8 "	9	2 " "	2.00	2 1/2 " "	2.75
1 "	8	2 " "	2.00	2 3/4 " "	2.75
1 1/8 "	7	2 1/2 " "	2.75	3 " "	3.50
1 1/4 "	7	2 1/2 " "	2.75	3 1/4 " "	3.50
1 3/8 "	6	3 " "	3.50		
1 1/2 "	6	3 " "	3.50		

Will send above 3/32 oversize unless otherwise ordered.

REECE'S SCREW PLATES



- Size A—Case containing Stock 22 in. long, Adjustable Tap Wrench, Taps, Dies and Collets, cutting $\frac{1}{8}$, $\frac{3}{16}$, $\frac{1}{4}$ and $\frac{5}{16}$ in. Complete, in case \$12.00
- Size B—Case containing Stock 20 in. long, Adjustable Tap Wrench, Taps, Dies and Collets, cutting $\frac{1}{8}$, $\frac{3}{16}$, $\frac{1}{4}$ and $\frac{5}{16}$ in. Complete, in case 17.50
- Size C—Case containing Stock 20 in. long, Adjustable Tap Wrench, Taps, Dies and Collets, cutting $\frac{1}{8}$, $\frac{3}{16}$, $\frac{1}{4}$, $\frac{5}{16}$, $\frac{3}{8}$ and $\frac{7}{16}$ in. Complete, in case 16.00
- Size D—Case containing Stock 26 in. long, Adjustable Tap Wrench, Taps, Dies and Collets, cutting $\frac{1}{8}$, $\frac{3}{16}$, $\frac{1}{4}$, $\frac{5}{16}$ and $\frac{3}{8}$ in. Complete, in case 22.00
- Size E—Case containing Stock 26 in. long, Adjustable Tap Wrench, Taps, Dies and Collets, cutting $\frac{1}{8}$, $\frac{3}{16}$, $\frac{1}{4}$ and $\frac{5}{16}$ in. Complete, in case 25.00
- Size F—Case containing Stock 53 in. long, Adjustable Tap Wrench, Taps, Dies and Collets, cutting $\frac{1}{8}$, $\frac{1}{4}$, $\frac{3}{8}$ and $\frac{1}{2}$ in. Complete, in case 37.50

Stocks, separate, 22 in. long, \$2.00 each; 40 in., \$5.00 each; 53 in., \$7.00 each.

REECE'S SCREW PLATE DIES AND COLLETS

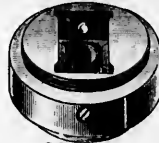

COLLET



DIE

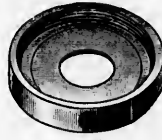

CAP

Size of Die.....	$\frac{1}{4}$ & $\frac{5}{16}$	$\frac{3}{8}$ & $\frac{7}{16}$	$\frac{1}{2}$ & $\frac{9}{16}$	$\frac{5}{8}$	$\frac{3}{4}$	$\frac{7}{8}$ & 1	$1\frac{1}{4}$ & $1\frac{1}{2}$	$1\frac{3}{4}$ & $1\frac{1}{2}$ inch.
Dies, per pair.....	\$1.00	1.25	1.50	1.75	2.00	2.75	4.00	5.00

Collets for 22 and 26 in. Stocks, \$0.50 each; for 40 and 53 in. Stocks, \$1.50 each.

Caps only, for Collets, 22 and 26 in Stocks, \$0.20 each; for 40 and 53 in. Stocks, \$0.50 each.

B. & C. BICYCLE SCREW PLATES



- No. 151—Case containing 5 sizes Taps, Dies and Guides, with Adjustable Tap Wrench per case \$6.30
 - No. 153—Case containing 6 sizes Taps, Dies and Guides, with Adjustable Tap Wrench per case 7.10
 - No. 157—Case containing 10 sizes Taps, Dies and Guides, with Adjustable Tap Wrench per case 10.20
- Regular Wire Gauge sizes of Dies and Taps carried in stock,
Nos. 11^{ss}, 12^{ss}, 13^{ss}, 13^{ss}, 14^{ss}, 15^{ss}, 16^{ss}, 17^{ss}.

Prices of Single Parts

Stocks, 6 inches long.....	each	\$1.00
Dies, $\frac{1}{8}$ inch diameter.....	"	0.40
Guides for Dies.....	"	0.20
Taps, see Machine Screw Taps, page 18; Wrenches, see page 17.	"	0.40
Cases.....	"	0.40

DUPLIX DIE STOCK



Can be opened and taken off without turning back, and instantly reset again for cut, thereby doing one-third more work than any other Die. Dies can be taken out and sharpened on grindstone and reset to desired size without trial.

A quarter turn of face-plates will instantly release or lock Dies firmly in position. No wrench or screw-driver needed for any adjustment.

FOR MACHINISTS AND MODEL MAKERS		
AA	$\left\{ \begin{array}{ccccccc} \frac{1}{32} & \frac{1}{24} & \frac{1}{20} & \frac{1}{18} & \frac{1}{16} & \frac{1}{14} & \frac{1}{12} \\ \text{Put up in case with 7 Taps and 7 sets of Dies..} & \dots & \dots & \dots & \dots & \dots & \dots \end{array} \right.$	\$22.50
A	$\left\{ \begin{array}{ccccccc} \frac{1}{20} & \frac{1}{18} & \frac{1}{16} & \frac{1}{14} & \frac{1}{12} & \frac{1}{11} & \frac{1}{10} \\ \text{Put up in case with 8 Taps and 7 sets of Dies..} & \dots & \dots & \dots & \dots & \dots & \dots \end{array} \right.$	30.00
FOR BLACKSMITHS AND CARRIAGE MAKERS		
AA	$\left\{ \begin{array}{cccc} \frac{1}{8} \& \frac{1}{16} & \frac{1}{8} \& \frac{1}{16} & \frac{3}{8} \& \frac{1}{16} & \frac{1}{2} \\ \text{Put up in case with 7 Taps and 4 sets of Dies..} & \dots & \dots & \dots & \dots & \dots & \dots \end{array} \right.$	18.00
A	$\left\{ \begin{array}{cccc} \frac{1}{8} \& \frac{1}{16} & \frac{3}{8} \& \frac{1}{16} & \frac{1}{2} \& \frac{1}{16} & \frac{3}{8} \& \frac{1}{16} \\ \text{Put up in case with 8 Taps and 4 sets of Dies..} & \dots & \dots & \dots & \dots & \dots & \dots \end{array} \right.$	25.50
Price of Extra Dies for Bolts		
No. AA, per single set		1.50
" A, " " "		1.90

MORSE TWIST DRILL AND MACHINE CO'S SCREW PLATES AND DIES

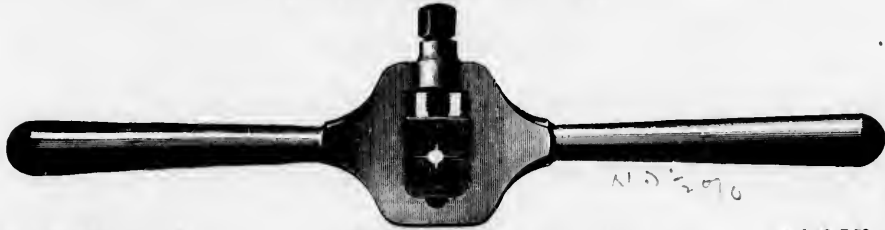

DIES FOR SCREW PLATES

Size A, with 3 pair Dies, cutting $\frac{1}{8}$, $\frac{3}{16}$, $\frac{1}{4}$ inch	each	\$ 7.50	\$1.50
" B, " 4 " " "	"	12.00	1.00
" C, " 4 " " "	"	15.00	2.00
" D, " 4 " " "	"	19.50	3.00
" E, " 6 " " "	"	54.45	4.95

TAPS EXTRA.

Other sizes in standard Dies can be supplied with above sets.

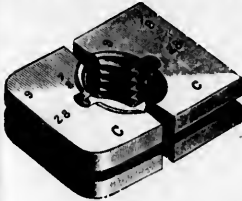

No. 1 SCREW PLATE AND DIES



MORSE'S ADJUSTABLE TAP WRENCH No. 0



No. 0 Wrench, fitting Taps from $\frac{1}{8}$ to $\frac{1}{2}$ inch inclusive, entire length $5\frac{1}{2}$ inches \$2.40
Fitting Squares from $\frac{1}{8}$ to $\frac{3}{8}$ inch inclusive.

For the use of Model Makers and Jewellers, cutting $\frac{1}{8}$, $\frac{3}{16}$, $\frac{1}{4}$, $\frac{5}{16}$, $\frac{3}{8}$, $\frac{7}{16}$, $\frac{1}{2}$ inch.
No. 1 Screw Plate, with 5 pairs of Dies and 5 Taps, as above \$6.75
Single pair of Dies 0.60

SCREW PLATES AND TAPS WITH SOLID DIES

Set A, cutting $\frac{1}{8}$, $\frac{3}{16}$, $\frac{1}{4}$ and $\frac{5}{16}$ inch	per set	\$5.00
" B, " $\frac{1}{8}$, $\frac{3}{16}$, $\frac{1}{4}$ and $\frac{5}{16}$ inch	"	8.75
" C, " $\frac{1}{8}$, $\frac{3}{16}$, $\frac{1}{4}$, $\frac{5}{16}$ and $\frac{3}{8}$ inch	"	10.00
" D, " $\frac{1}{8}$, $\frac{3}{16}$ and $\frac{1}{4}$ inch	"	5.75
" E, " $\frac{3}{8}$, $\frac{1}{2}$ and 1 inch	"	8.50
" F, " $\frac{1}{2}$, 1, 1 $\frac{1}{4}$ and 1 $\frac{1}{2}$ inch	"	14.75
" G, " 1 $\frac{1}{2}$, 1 $\frac{3}{4}$, 1 $\frac{1}{2}$ and 1 $\frac{1}{4}$ inch	"	22.00

For Price of Dies separate, see page 13.



No. 181A

"STUBS" SCREW PLATES AND TAPS SOLID PLATES.

No. 179, cutting 7 sizes from $\frac{1}{8}$ to $\frac{1}{4}$ inch	each	\$1.45
" 179, " 8 " " " "	"	1.65
" 179, " 10 " " " "	"	2.25
" 181, " 10 " " " "	"	2.25
" 181A, " 10 notched sizes from $\frac{1}{4}$ to $\frac{1}{2}$ in.	"	3.20
" 181A, " 10 " " " "	"	4.50

GERMAN SCREW PLATES AND TAPS

ON CARDS.



No. 847—6 inch, adjustable, cutting 5 sizes, $\frac{1}{8}$ to $\frac{1}{4}$ inch each \$1 90
" 847—8 " " " " 6 " $\frac{1}{8}$ to $\frac{1}{4}$ " " " " 2 15

BLACKSMITHS' STOCKS, DIES AND TAPER TAPS

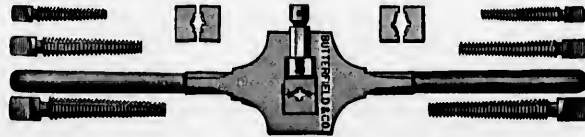

- 2 1/2 70

Number.	Size Right Hand.	Threads to the Inch.	Size Left Hand.	Threads to the Inch.	Number of Taps.	Number of Dies.	Price each.
7	1 1/4 to 1 in.	8 and 10	1 1/4 to 1 in.	8	6	3	\$12.00
17	1 " "	9 and 12	1 " "	9	6	3	9.00
19	1 " "	9, 12 and 14	1 " "	9	6	3	9.00
25	3/4 " "	10 and 16	3/4 " "	10	6	3	6.50
27	3/4 " "	10, 12 and 16	3/4 " "	10	6	3	6.50
45	3/4 " "	12 and 16	3/4 " "	12	6	3	5.50
47	3/4 " "	12, 14 and 18	3/4 " "	12	6	3	5.50
49	3/4 " "	14 and 18	3/4 " "	14	6	3	4.50
51	3/4 " "	14, 18 and 22	3/4 " "	14	6	3	4.50



- 2 1/2 70

Number.	Size Right Hand.	Threads to the Inch.	Size Left Hand.	Threads to the Inch.	Number of Taps.	Number of Dies.	Price each.
21	1 to 3/4 in.	9 and 12	1 to 3/4 in.	9	4	3	\$6.00
23	1 " "	9, 10 and 14	1 " "	9	3	3	5.00
32	1 " "	10 and 14	1 " "	10 and 14	4	4	5.00
34	3/4 " "	10, 12 and 16	3/4 " "	10 and 14	3	3	4.50
35	3/4 " "	10 and 14	3/4 " "	10 and 14	2	2	4.00
37	3/4 " "	14, 18 and 22	3/4 " "	14	6	3	4.25
41	3/4 " "	16, 20 and 26	3/4 " "	14	6	3	3.25
42	3/4 " "	14 and 20	3/4 " "	14	6	3	3.50
53	3/4 " "	16, 20 24 and 32	3/4 " "	14	4	4	2.75

EXTRA BLACKSMITHS' DIES

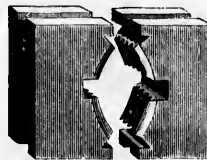

- 2 1/2 70

	Price per Full Set.	Price Per Pair.		Price per Full Set.	Price Per Pair.
For No. 7 Stock	\$4.40	\$1.50	For Nos. 25, 27, 32, 45 and 47 Stock	\$2.80	\$0.95
For Nos. 17 and 19 Stock	3.15	1.05	For Nos. 34, 49 and 51 Stock	2.50	0.95
For No. 21 Stock	2.50	1.05	For Nos. 35, 37, 41 and 42 Stock	1.90	0.95

In ordering new dies the best way is to send us an old die by mail.

THE WILEY & RUSSELL MFG. CO'S LIGHTNING ADJUSTABLE TAP WRENCHES

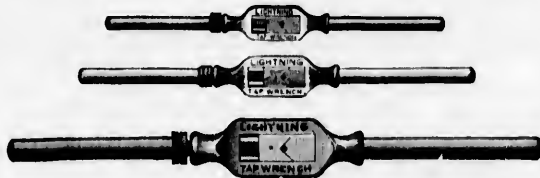

They will be found extremely convenient and their use is a great saving of taps.
They are made in the very best manner and of the very best material.

No. 330—Size A, length 10½ inches, for Taps ⅝ in. to ⅞ in.....	each	\$4.50
“ 331— “ B “ 15 “ “ ⅞ “ 1 “	“	5.25
“ 332— “ C “ 20 “ “ 1 “ 1 ½ “	“	7.50

These Wrenches are light, strong and durable.

GREEN RIVER ADJUSTABLE TAP WRENCHES

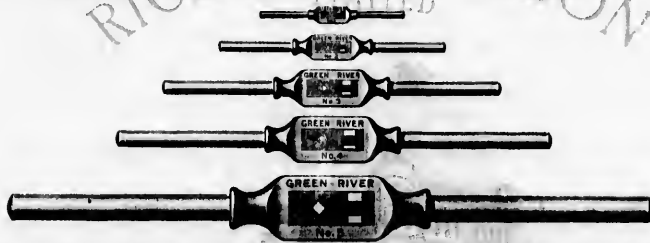

The handles are hollow for sake of lightness, and both are firmly fixed, the motion to the jaws being given through an independent knurled nut. The jaws, of ample size, are made of fine tool steel, and run on gibs full length, true and strong.

The stock is drop-forged, and the whole thoroughly made in every particular, complete and durable.

No. 335—Size No. 1, length 7 inches, for Taps ⅜ inch and smaller.....	each	\$2.63
“ 336— “ 2 “ 11 “ “ ½ to ¾ inch inclusive	“	3.53
“ 337— “ 3 “ 16 “ “ “ “	“	4.50
“ 338— “ 4 “ 19 “ “ “ “	“	6.00
“ 339— “ 5 “ 31 “ “ “ “	“	12.00

ADJUSTABLE TAP WRENCHES



Size A, Fitting Taps from ¼ to ½ inch inclusive, length 13 inches.....	price, each	\$1.50
“ B, “ “ “ ½ “ “ “ “ “ “ 18 “	“	6.00
“ C, “ “ “ “ 1 ¼ “ “ “ “ “ “ 23 “	“	7.50

SOLID TAP WRENCHES

ADJUSTABLE TAP WRENCHES



No. 0—5 inches long, for Taps ⅛ to ¼ in.....	each	\$1.00
“ 1—8 “ “ “ ¼ “ “ “ “ “ “	“	1.50
“ 2—12 “ “ “ “ “ “ “ “ “	“	2.00
“ 3—14 “ “ “ “ “ “ “ “ “	“	3.00
“ 4—19 “ “ “ “ “ “ “ “ “	“	4.00

No. 11—Holds ⅛, ¼ and ¾ in. Taps.....	each	\$0.40
“ 12— “ “ “ “ “ “ “ “ “	“	0.75
“ 13— “ “ “ “ “ “ “ “ “	“	1.00
“ 14— “ “ “ “ “ “ “ “ “	“	1.50

Number Dies,	Price each,
3	\$12.00
3	9.00
3	9.00
3	0.50
3	6.50
3	5.50
3	5.50
3	4.50
3	4.50

Number Dies,	Price each,
3	\$6.00
4	5.00
4	5.00
4	4.50
3	4.00
3	4.25
3	3.25
3	3.50
4	2.75

Price per Full Set,	Price Per Pair,
\$2.80	\$0.05
2.50	0.05
1.90	0.05

THE WILEY & RUSSELL MFG. CO'S

GREEN RIVER PATENT RIM WRENCH

No. 600



FOR NUTS ON THE TIRE BOLTS INSIDE THE FELLOE.

No. 600—This is a labor-saving tool for taking off and putting on nuts in an awkward place inside carriage felloe. It is adapted for use on Nuts $\frac{1}{2}$, $\frac{3}{8}$, $\frac{1}{2}$ inch. Price \$2.25

LIGHTNING NUT WRENCHES FOR BIT BRACE USE



FOR SQUARE AND HEXAGON NUTS.

No. 002—Set of 5 Wrenches for Nuts $\frac{1}{2}$, $\frac{3}{8}$, $\frac{1}{2}$, $\frac{3}{4}$ and $\frac{1}{2}$ inch. Price \$1.15

CROSS RIM WRENCH



No. 601—For Nuts $\frac{3}{8}$, $\frac{1}{2}$, $\frac{3}{4}$ and $\frac{1}{2}$ inch each \$0.38

BLACKSMITHS' TAPER AND PLUG TAPS



RIGHT OR LEFT HAND.

Size.	Threads to the Inch.	Price, each Tap.	Size.	Threads to the Inch.	Price, each Tap.
3/16 inch.	18, 20, 22, 24 and 26	\$0.30	9/16 inch.	12 and 14	\$0.50
1/4 "	14, 16, 18, 20, 22 and 24	0.30	5/8 "	10, 12, 14 and 16	0.50
5/16 "	14, 16, 18, 20 and 22	0.30	3/4 "	8, 9, 10, 12 and 14	0.65
3/8 "	12, 14, 16, 18 and 20	0.35	7/8 "	9 and 10	0.80
7/16 "	12, 14, 16, 18 and 20	0.40	1 "	7, 8 and 9	1.25
1/2 "	10, 12, 14, 16 and 18	0.40	1 1/4 "	6, 7, 8 and 9	1.75

MACHINE SCREW TAPS



Number	2	4	6	8	10	12	14	16	18	20	24 inch.
Price, each	\$0.25	0.35	0.35	0.35	0.35	0.35	0.38	0.38	0.38	0.45	0.45

WILEY & RUSSELL SCREW PLATE TAPS



FOR X, X FULL-MOUNTED AND No. O SETS.

Price for regular sizes as enumerated with sets on pages 7 and 9.....each \$0.10

STOVE BOLT TAPS



Size.....	5/32	3/16	7/32	1/4	5/16	3/8 inch.
Price, each..	\$0.55	0.35	0.35	0.38	0.38	0.45

BIT BRACE TAPS



Size.....	3/16	1/4	5/16	3/8	7/16	1/2 inch.
Price, each..	\$0.50	0.50	0.55	0.60	0.70	0.80

TAPS PULLEY TAPS



PRICE EACH.

Sizes	No. of Threads to Inch.	6	8	10	12	14	16	18	20	22	24
		Inch.	Inch.	Inch.	Inch.	Inch.	Inch.	Inch.	Inch.	Inch.	Inch.
3/8	11	\$0.80	0.00	1.10	1.30	1.40	1.00	1.80
7/16	11	\$0.00	1.00	1.20	1.40	1.50	1.70	1.00
1/2	12	\$1.00	1.30	1.40	1.50	1.00	1.80	2.00	2.20
9/16	12	\$1.10	1.35	1.45	1.55	1.70	1.85	2.10	2.30	2.50
5/8	11	\$1.20	1.40	1.50	1.60	1.75	1.90	2.20	2.40	2.60	2.80

STAY BOLT TAPS THREAD



PRICE EACH.

Diameter, Inch.	16	18	21	24	27	30	33	36	39	42	48	54
3/4, 13/16, 7/8	\$ 5.00	7.20	8.00	8.80	10.40	13.00	14.00	15.00	16.50	18.00	19.00	21.00
15/16, 1	\$ 6.00	8.50	9.35	10.20	12.25	14.25	15.40	16.50	18.00	19.75	21.00	22.25
1 1/16, 1 1/8	\$ 7.00	9.50	10.35	11.20	13.25	15.25	16.40	17.50	20.00	22.00	23.50	25.00
1 3/16, 1 1/4	\$ 8.00	10.50	12.00	12.75	14.75	16.50	18.00	19.50	22.00	24.00	25.50	27.00
1 5/16, 1 3/8	\$11.00	12.50	14.00	15.00	17.00	18.50	20.00	21.50	24.00	26.00	28.00	30.00
1 7/16, 1 1/2	\$13.00	14.50	16.00	17.00	19.00	20.00	22.00	23.50	26.00	28.00	30.00	32.00

All orders for these Taps should give exact diameter and number of threads per inch, also length of parts A, B, C, D and E. Unless otherwise ordered, we shall send these Taps with twelve threads to the inch, exact size.

MACHINE, OR NUT TAPS

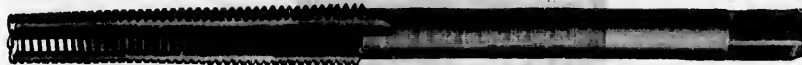

Price, each Tap.
..... \$0.50
..... 0.50
..... 0.65
..... 0.80
..... 1.25
..... 1.75

Diameter.....	3/16	1/4	5/16	3/8	7/16	1/2	9/16	5/8	11/16	3/4	13/16	inch.
No. of Threads	24	20	18	10	14	12	12	11	11	10	10	
Price, each....	\$1.00	0.60	0.70	0.80	0.90	1.00	1.15	1.30	1.45	1.60	1.80	
Diameter.....	7/8	15/16	1	1 1/8	1 1/4	1 1/2	1 5/8	1 3/4	1 7/8	2	2 1/4	inch.
No. of Threads	0	0	8	7	7	6	6	5	5	5	4 1/2	
Price, each....	\$2.10	2.40	2.80	3.20	3.70	4.20	4.70	5.30	6.00	6.80	7.70	

These will be sent $\frac{1}{16}$ or $\frac{1}{8}$ oversize unless otherwise ordered.

MACHINISTS' HAND TAPS



Taper.

Diameter.....	3/16	1/4	5/16	3/8	7/16	1/2	inch.
No. of Threads.	24	20	18	16	14	12	
Price, each....	\$0.45	0.45	0.50	0.55	0.60	0.70	



Plug.

Diameter.....	9/16	5/8	3/4	7/8	1	1 1/8	inch.
No. of Threads.	12	11	10	9	8	7	
Price, each....	\$0.80	0.90	1.20	1.00	2.00	2.25	



Bottoming.

Diameter.....	1 1/4	1 3/4	1 1/2	1 5/8	1 7/8	2	inch.
No. of Threads.	7	6	5	5	5	4 1/2	
Price, each....	\$2.00	3.00	3.50	5.00	5.80	6.70	

In ordering mention if exact, $\frac{1}{16}$ or $\frac{1}{8}$ oversize, and say whether Taper, Plug or Bottoming is wanted.

THE WILEY & RUSSELL MFG. CO'S

BICYCLE TAPER TAPS FOR REPAIRERS

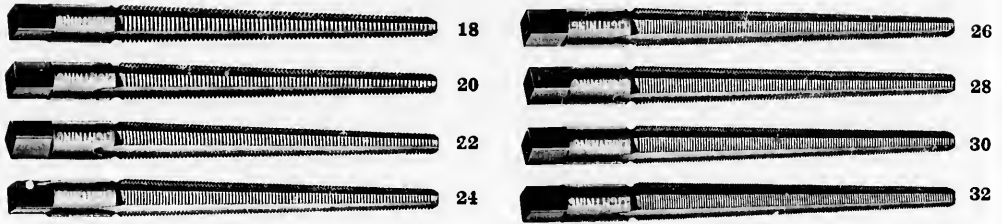

No. 1	Size $\frac{1}{16}$	tapering to $\frac{3}{16}$	4 inches long, Threads 18 to 32.....	each	\$1.00
" 2	" $\frac{1}{8}$	" $\frac{3}{8}$	4 " " " 18 to 32.....	"	1.30
" 3	" $\frac{1}{4}$	" $\frac{3}{4}$	4 " " " 18 to 32.....	"	1.65

Finely made, machine relieved with very gradual taper.

B. & CO'S BICYCLE TAPER TAPS FOR REPAIRERS

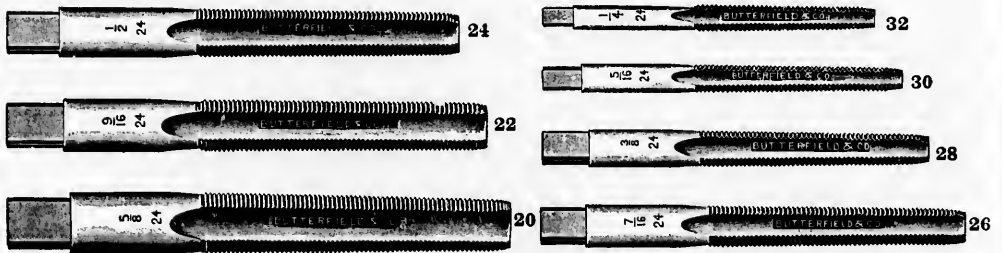

Diameter $\frac{1}{4}$	Threads 20 to 32.....	each	\$0.45	Diameter $\frac{1}{2}$	Threads 20 to 32.....	each	\$0.70
" $\frac{3}{8}$	" 20 to 32.....	"	0.50	" $\frac{3}{8}$	" 20 to 32.....	"	0.80
" $\frac{1}{2}$	" 20 to 32.....	"	0.55	" $\frac{1}{2}$	" 20 to 32.....	"	0.90
" $\frac{3}{4}$	" 20 to 32.....	"	0.60				

The "Diameter" given in this table is that of the largest part of the Tap.

INSIDE AND OUTSIDE CHASERS



Chasers for cutting standard pitches, 3 to 8	each	\$1.15
" " " 9 to 30	"	0.80

PIPE TAPS AND REAMERS



Size	$\frac{1}{4}$	$\frac{1}{2}$	$\frac{3}{4}$	1	$1\frac{1}{4}$	$1\frac{1}{2}$	2	$2\frac{1}{2}$	3 inch.
Pipe Taps	\$1.12	1.25	1.50	1.87	2.50	3.12	3.75	4.62	6.25 10.50 15.00
Pipe Reamers	\$1.12	1.25	1.50	1.87	2.50	3.12	3.75	4.62	6.25 10.50 15.00

Pipe Taps with Right or Left Hand Threads and Reamers having taper $\frac{1}{4}$ inch per foot, also Plug Pipe Taps, are kept in stock.

THE WILEY & RUSSELL MFG. CO'S

HAND BOLT-CUTTER AND NUT-TAPPER No. 0

No. 750

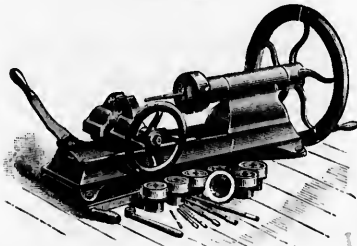

Made to be bolted to the bench or table. Fitted with 7 sizes, from $\frac{1}{4}$ inch to $\frac{3}{4}$ inch. Usual assortment, $\frac{1}{4}$, $\frac{3}{8}$, $\frac{1}{2}$, $\frac{5}{8}$ and $\frac{3}{4}$ inch.

No. 750—Price, with Taps, Dies in Collets, Tap Chuck, Wrench, etc., complete, with balance wheel.....\$75.00

No. 751—As above, but without balance wheel... 70.50
Shanks of Collets, 2 inches in diameter. Weight, 200 pounds.

When desired, we furnish $\frac{1}{4}$ inch Tap, Die and Collet with this machine, charging \$6.15 extra, but recommend the No. 20 or No. 10 Machine for sizes larger than $\frac{1}{4}$ inch.

The cut represents the Machine with a balance-wheel attached. We can recommend the wheel as a decided improvement, it being very handy in running back fast after finishing a screw. Pulley for belt can be furnished instead of the balance-wheel. when desired, at the same price, making a very handy and efficient machine for light work by power.

No. 755

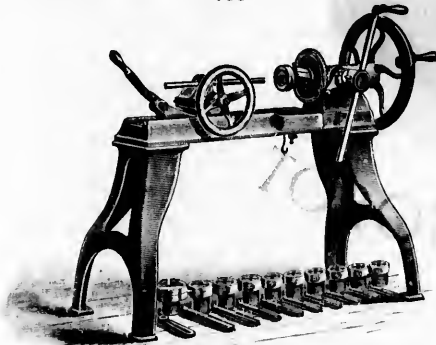

No. 20, MOUNTED.

For the bench or mounted. Fitted with 9 sizes, $\frac{1}{2}$ inch to 1 inch. Usual assortment, $\frac{1}{2}$, $\frac{5}{8}$, $\frac{3}{4}$, $\frac{7}{8}$, $\frac{15}{16}$, $\frac{1}{2}$, $\frac{3}{4}$ and 1 inch.

No. 754—Price, with Taps, Dies in Collets, Chuck, Wrenches, etc., complete for the bench.....\$105.00

No. 755—Mounted, with iron legs..... 115.50
Shanks of Collets are 2 inches in diameter.
Price of Collets, each..... 1.35

For Prices of Taps and Dies separately, see pages 13 and 19.

BOLT-CUTTER, NUT-TAPPER AND PIPE-THREADER No. 10

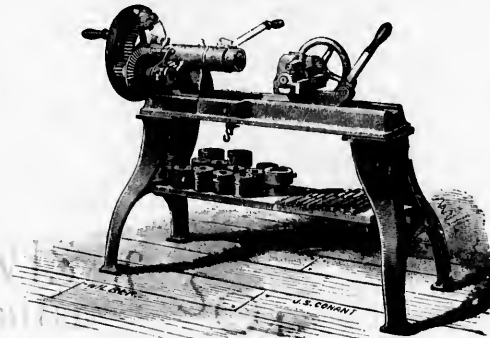

MOUNTED.

The capacity of this machine is, for bolts and nuts, $\frac{3}{8}$ inch to $1\frac{1}{2}$ inch, and for pipe, $\frac{1}{2}$ inch to 2 inch. Any crooked or odd-shaped pieces may be threaded without straightening. The engraving shows a $\frac{1}{2}$ inch staple in the vise. The spindle is hollow, and bolts of any length may be cut. Bolts and nuts, say $\frac{3}{4}$ inch and under, are rapidly done, with the gears out, by the handle on the balance-wheel, in which wheel, moreover, the crank may be placed when desired. For large work the gearing multiplies the direct force of the crank at the side of the machine between six and seven-fold, and the arrangement is such that the Die being run sufficiently far on the work, the gears may instantly be thrown out and the Die whirled swiftly back off the thread by means of the balance-wheel.

Extra steel dogs are attached to the vise to secure large smooth pipe which might sometimes slip in the jaws.

The oil poured on the work is drained into a basin under the chuck, and can be used again.

The remarkably great range of this machine makes it a favorite—it being equally excellent on very large, very small, crooked or straight bolts (with nuts), and on pipe.

Weight of Bench Machine, boxed, 450 pounds; Mounted Machine, 600 pounds.

We subjoin two different assortments or sizes of Taps and Dies, with prices.

No. 758—Assortment 1—Machine complete, with Taps and Dies in Collets for bolts and nuts, $\frac{1}{4}$, $\frac{3}{8}$, $\frac{1}{2}$, $\frac{5}{8}$, $\frac{3}{4}$, $\frac{7}{8}$, $\frac{15}{16}$, 1, 1 $\frac{1}{4}$, 1 $\frac{1}{2}$, 1 $\frac{3}{4}$ and 1 $\frac{1}{2}$ inch Chuck, Wrenches, etc., for bench. Price.....\$206.25

No. 759—Same as above, mounted on iron legs. Price..... 217.50

No. 762—Machine complete, with Adjustable Dies and Collets for pipe, right-hand, $\frac{1}{2}$, $\frac{3}{4}$, 1, 1 $\frac{1}{4}$, 1 $\frac{1}{2}$ and 2 inch, for bench. (No Tap Chuck.) Price..... 145.50

No. 763—Same as above, mounted on iron legs. Price..... 156.75

Pipe Set—Can supply Adjustable Pipe Dies and Collets right hand, $\frac{1}{2}$ to 2 inches, 9 sizes, with assortment No. 1, at extra... 45.00

For Prices of Taps and Dies, see pages 13 and 19.

Holders supplied for using common solid Pipe Dies with this Machine, when desired, at \$1.50 each. Shanks of Collets for Dies are 3 inches in diameter.

Will send the Taps and Dies for above $\frac{3}{4}$ oversize, V thread, unless otherwise ordered.

26
28
30
32
each \$1.00
1.30
1.65
32
30
28
26
each \$0.70
0.80
0.90
each \$1.15
0.80

3 inch.
15.00
15.00
Pipe Taps, are

THE WILEY & RUSSELL MFG. CO'S

GREEN RIVER BOLT-CUTTER, NUT-TAPPER AND PIPE-THREADER

No. 42

Showing Plain Countershaft.

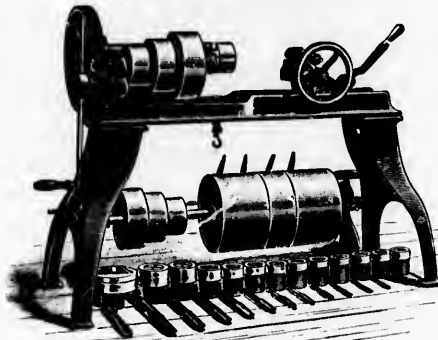

For Power or Hand Use.

The capacity of this machine is for $\frac{1}{4}$ to $1\frac{1}{2}$ inch bolts and nuts and $\frac{1}{4}$ to 2 inch pipe. It does equally well straight or crooked work. Has three changes of speed; takes 3 in. belt; hollow spindle; hole through spindle $1\frac{1}{2}$ inch. Collets have 3 inch shanks.

The vise is made to center and hold properly the various sizes, and to take work of irregular shapes. The attachment to enable this machine to be used by hand is frequently of service on repair work at times when power is not available. It can be thrown out of gear when not in use.

Speed of countershaft should be 125 revolutions per minute. Weight of machine complete, 650 lbs.

No. 780—Assortment 1—Machine complete, with Chuck and Wrenches and Plain Countershaft, having tight and loose pulleys 12 inches in diameter, and Taps, Dies and Collets for bolts and nuts $\frac{1}{4}$, $\frac{1}{2}$, $\frac{3}{4}$, 1 , $1\frac{1}{2}$ and $1\frac{3}{4}$ in \$225.00

No. 781—Assortment 2—Machine complete, with Chuck and Wrenches and Plain Countershaft, having tight and loose pulleys 12 inches in diameter, and Taps, Dies and Collets for bolts and nuts, $\frac{1}{4}$, $\frac{1}{2}$, $\frac{3}{4}$, 1 , $1\frac{1}{2}$ and $1\frac{3}{4}$ in 205.50

No. 782—Assortment 3—For Pipe. Machine complete (no tap chuck), with Wrenches and Plain Countershaft, having tight and loose pulleys 12 inches in diameter, and one right-hand Adjustable Pipe Die and Collet, each $\frac{1}{4}$, $\frac{1}{2}$, $\frac{3}{4}$, 1 , $1\frac{1}{2}$ and 2 in. 105.75

Can supply Adjustable Pipe Dies and Collets, right-hand, $\frac{1}{4}$ to 2 inches, nine sizes, with Assortments Nos. 1 and 2 (Patent Adjustable Dies), at extra 45.00

Extra for $1\frac{1}{2}$ inch Tap, Die and Collet (for bolts and nuts) 11.25

Extra for $1\frac{1}{4}$ inch Tap, Die and Collet (for bolts and nuts) 12.75

Will send the Dies and Taps, for bolts and nuts, for this Machine $\frac{1}{2}$ oversize, V thread, unless otherwise ordered.

GREEN RIVER BOLT-CUTTER, NUT-TAPPER AND PIPE-THREADER

No. 45

Shown with Patent Friction Countershaft

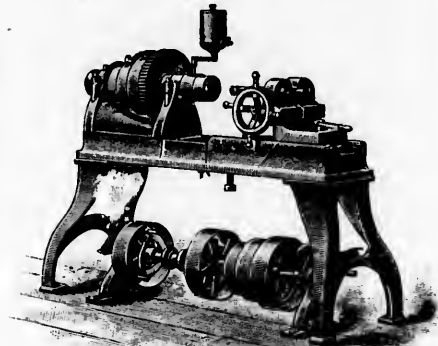

For Power Only.

The capacity is for bolts and nuts $\frac{1}{4}$ to 2 inches, and pipe $\frac{1}{4}$ to 2 inches. It is powerfully back-gear. The gears can be thrown out, as in an engine lathe, for small work and also in running back after cutting screws. Has 6 changes of speed; takes $3\frac{1}{2}$ inch belt. The chips and oil are caught in bed, and the oil can be strained and used again. Has oil reservoir; hollow spindle; hole through spindle, $2\frac{1}{2}$ inches; collets have 3 inch shank. The vise is the best one we make, and will hold properly the various shapes and sizes of iron, the jaws having 3 changes to enable iron, large or small, to be properly grasped. The great advantage of this, in keeping the jaws sharp and in good order, will be appreciated.

Speed of countershaft should be 125 revolutions per minute. Weight of Machine, complete, 1000 pounds.

No. 785—Assortment 1—Machine complete, with Chuck and Wrenches and Patent Friction Countershaft, 12 inches in diameter, and Taps, Dies and Collets for bolts and nuts $\frac{1}{4}$, $\frac{1}{2}$, $\frac{3}{4}$, 1 , $1\frac{1}{2}$, $1\frac{3}{4}$, $1\frac{1}{2}$ inches \$300.00

No. 786—Assortment 2—Machine complete with Chuck and Wrenches and Patent Friction Countershaft, 12 inches in diameter, and Taps, Dies and Collets for bolts and nuts $\frac{1}{4}$, $\frac{1}{2}$, $\frac{3}{4}$, 1 , $1\frac{1}{2}$, $1\frac{3}{4}$ inches 330.00

No. 787—Assortment 3—For Pipe. Machine complete (no Tap Chuck) with Wrenches, Patent Friction Countershaft, 12 inches in diameter, and one right-hand Adjustable Pipe Die and Collet, each $\frac{1}{4}$, $\frac{1}{2}$, $\frac{3}{4}$, 1 , $1\frac{1}{2}$ and 2 inches 307.50

Can supply Adjustable Pipe Dies and Collets, right-hand, $\frac{1}{4}$ to 2 inches, 9 sizes, with Assortments Nos. 1 and 2, at extra 45.00

Extra for $1\frac{1}{2}$ inch Tap, Die and Collet (for bolts and nuts) 22.15

Extra for 2 inch Tap, Die and Collet (for bolts and nuts) 27.00

Will send the Dies and Taps, for bolts and nuts, for this Machine $\frac{1}{2}$ oversize, V thread, unless otherwise ordered.

If Plain Countershaft, having tight and loose pulleys, 12 inches in diameter, is wanted, instead of our Patent Friction Countershaft, we can reduce price on above assortments by \$10.50

THE WILEY & RUSSELL MFG. CO'S

GREEN RIVER PATENT OPENING DIES, HOLDERS AND CARRIAGE

SUPPLIED WITH BOLT CUTTER, No. 50

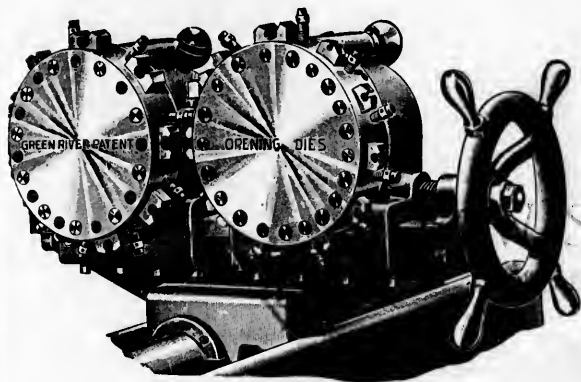

The Dies do not need to be adjusted, but stand always ready for work. With Opening-Dies, bolts or pipe are instantly released when threaded, without running backwards over the screw, thereby saving nearly half the time, and also much wear on the Dies. By simply turning the hand wheel the Dies separate, and the work can be taken out.

We know of no Opening-Die arrangement which can approach ours for quickness and convenience in threading bolts or pipe. It is very simple and strong, so that workmen of ordinary skill can use it with good results and without the danger of breaking.

THE DIES are secured in two equal wheels (Die-Holders), set side by side and controlled by a right and left screw, each Die being divided, the half in one wheel opposite to the half in the other, in such a manner that a complete working Die is made by bringing the wheels together, and the finished screw released by separating them, thus saving running back over the threads.

Each Die has independent stop-pins controlling its cut, which can be either shortened or lengthened, enabling a perfect adjustment to be maintained, all the different Dies standing ready for use, so that any size may at once be brought into line by turning the wheels to the proper places, thereby making it possible to thread a lot of bolts of different sizes almost as quickly as if all were of the same size. Each Die cuts a full thread at one operation, and the hollow spindle allows a screw of any desired length to be cut.

Machine only, including Chuck and Nut-Holders.....	\$232.50
Plain Countershaft, having one light and loose pulley, 12 in. diameter, 3½ in. face, for cutting right-hand threads only.....	22.50
Set for Pipe—Consisting of one pair of Die-Holders (Disks), and Pipe Dies (right-hand), adjusted, of following sizes: ¼, ½, ¾, 1, 1¼, 1½, 2 inches.....	75.75
Set for Bolts—Consisting of one pair of Die-Holders (Disks), and Dies and Taps, adjusted, of the following sizes: ¾, 1, 1¼, 1½, 1¾, 2 inches, for bolts and nuts.....	77.63
No. 50—Complete as above.....	\$408.38

Capacity is for pipe ¼ to 2 inches, and bolts and nuts ¼ to 2 inches.

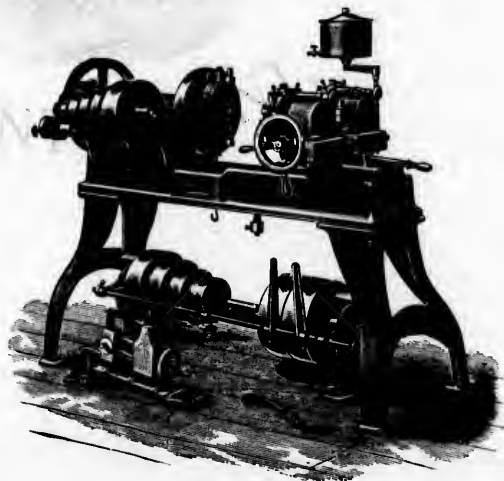

No. 50.

FORBES' PATENT DIE STOCKS

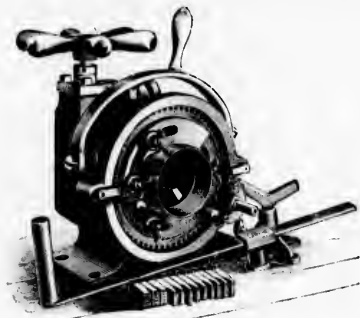

Front View.



Back View.

Hand Machine.

The above cuts illustrate the front and back views of the Nos. 30 and 34 Forbes' Patent Die Stocks. The Dies are set by turning the face plate to the proper graduation, and any variation in the fittings may be allowed for, and the pipe cut either over or under standard size.

- No. 30—Hand Machine; Threads $\frac{1}{4}$, $\frac{3}{8}$, $\frac{1}{2}$, $\frac{3}{4}$, 1, $1\frac{1}{4}$, $1\frac{1}{2}$ and 2 inch pipe, both Right and Left. Weight, 80 lbs.
 Price, with Opening and Adjustable Dies, complete..... \$95.00
- No. 34—Hand Machine; Threads 1, $1\frac{1}{4}$, $1\frac{1}{2}$, 2, $2\frac{1}{2}$ and 3 inch pipe, Right Hand, and 1, $1\frac{1}{4}$, $1\frac{1}{2}$ and 2 inch pipe, Left Hand. Weight, 115 lbs. Price, with Opening and Adjustable Dies, complete..... 150.00

SAUNDERS' PIPE-CUTTING AND THREADING MACHINE

FOR PIPE.

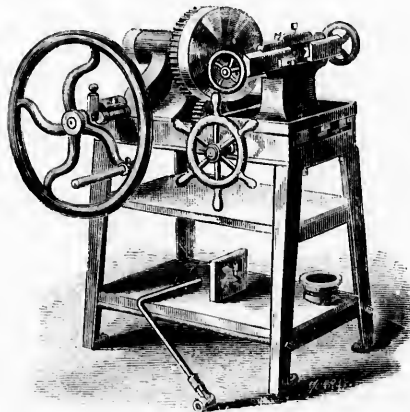

No. 1

Hand Machine.

Cutting and threading pipe from $\frac{1}{4}$ inch to 2 inches in diameter, with universal chuck, fly wheel and solid dies, right hand, also a set of sockets for making nipples $\frac{1}{4}$ to 2 inches, complete..... \$216.00

Power and Hand Machine.

Cutting and threading pipe from $\frac{1}{4}$ inch to 2 inches in diameter, with universal chuck, cone pulleys, countershaft and solid dies, right hand, also a set of sockets for making nipples $\frac{1}{4}$ to 2 inches, complete, 270.00

Speed of Countershaft, 150 revolutions per minute.
 Diameter of Pulleys, 11 inches, two loose, each 7 inch face, one fast $3\frac{1}{2}$ inch face.
 Weight of Hand Machine, 550 lbs.
 Weight of Power Machine, 700 lbs.

THE WILEY & RUSSELL MFG. CO'S

LIGHTNING SCREW PLATES

FOR PIPE



No. 250—Set C, consisting of Stock 35 inches long and 5 sizes of Dies (right or left), and Guides for $\frac{1}{4}$, $\frac{1}{2}$, $\frac{3}{4}$ and 1 inch pipe. Complete, as above, in substantial case...\$18.00

$\frac{1}{4}$ inch supplied with this set, extra 2.65

Parts separately

Stock 35 inches long.....each 5.25
Dies....." 2.25
Guides....." 0.38

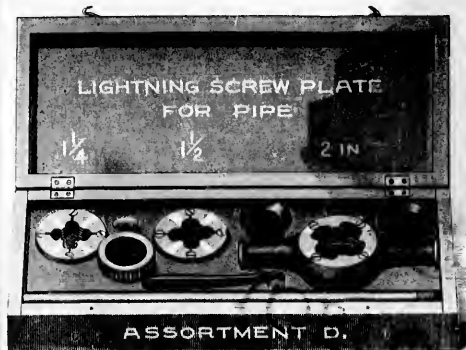

No. 251—Set D, consisting of Stock 53 inches long with a Leader Screw and 3 sizes of Dies (right or left) and Guides for 1, $1\frac{1}{2}$ and 2 inch pipe. Complete, as above, in substantial case\$30.00

Size 1 inch, if ordered with this set (including bushing and guide), extra 4.50

Parts Separately

Stock 53 inches long.....each 10.50
Dies....." 6.00
Guides....." 0.75

No. 252—Sets C and D combined with Dies and Guides, cutting $\frac{1}{4}$ to 2 inch pipe. Complete, in case 48.00

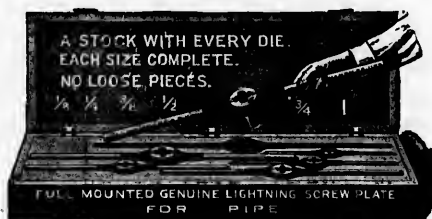

Full Mounted.

No. 260—Set of 5 sizes, $\frac{1}{4}$ to 1 inch. A Stock to each Die, for $\frac{1}{4}$, $\frac{1}{2}$, $\frac{3}{4}$, 1 inch pipe. 5 Stocks and 5 Dies complete, without case...\$18.00

No. 261—Same as 260, but with case 21.75

No. 262—Set of 6 sizes, $\frac{1}{4}$ to 1 inch. A Stock to each Die, $\frac{1}{4}$, $\frac{1}{2}$, $\frac{3}{4}$, 1 inch. 6 Stocks and 6 Dies, complete, without case 20.65

No. 263—Same as 262, but with case 24.38

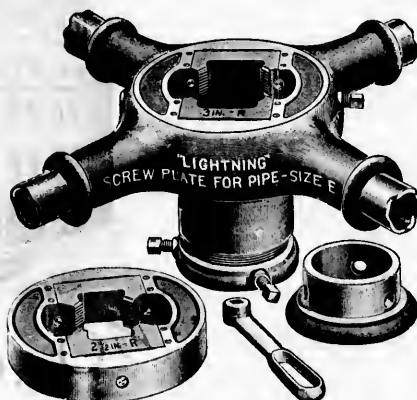

No. 253—Set E, consisting of Stock with Leader Screw, and 2 sizes of Dies (right or left), Collets, Guide and Wrench. Sizes $2\frac{1}{2}$ and 3 inches. Complete as above (no case)..... \$60.00

Outside diameter of Collets, $7\frac{1}{2}$ inches.

Parts Separately

Stock.....each 30.00
Dies....." 11.25
Collets....." 3.75
Guide....." 1.50
Wrench....." 0.38

These Dies are always ready for use, like solid Dies. Adjustable for irregular sizes of fittings and for wear.

JARECKI PATENT SCREW PLATE AND PIPE CUTTER

No. 567

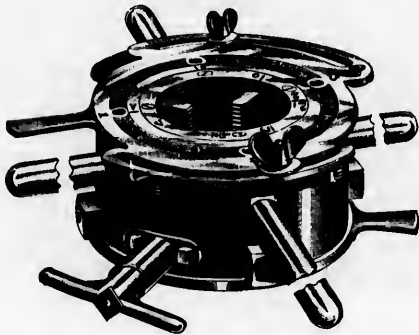

The Nos. 1, 2, 3 and 3½ have Two Handles.
Nos. 4A and 4B have Four Handles.
Nos. 5 and 5A have Five Handles.



Has Adjustable Self-Centering Dies and Guides. The Dies and Pipe-Cutting Knife are easily removed and sharpened by grinding.

No. 1—Threads and cuts $\frac{1}{4}$, $\frac{3}{8}$, $\frac{1}{2}$ and $\frac{3}{4}$ inch Pipe.....	price	\$14.00						
" 2 " " " $\frac{1}{2}$, $\frac{3}{4}$, 1 and 1½ "	"	16.00						
" 3 " " " 1, 1½, 1¾ and 2 "	"	20.00						
" 3½ " " " $\frac{1}{2}$, $\frac{3}{4}$, 1, 1½, 1¾ and 2 "	"	22.50						
" 4A " " " 1½, 2, 2½ and 3 "	"	35.00						
" 4B " " " 2½, 3, 3½ and 4 "	"	50.00						
" 5 " " " 4½, 5 and 6 "	"	75.00						
" 5A " " " 6, 7 and 8 "	"	125.00						
Nos.	1	2	3	3½ (2 sets)	4A	4B	5	5A
Dies, per set, right or left hand.....	\$2.00	2.00	2.00	4.00	3.00	3.00	6.00	6.00
Knives.....	\$0.40	0.40	0.40	0.40	0.50	0.50	0.60	0.60

JARECKI RATCHET SCREW PLATE WITH LEADER SCREW

No. 570

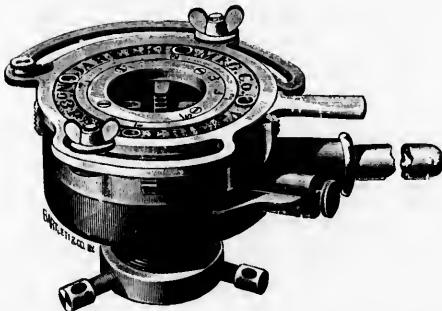

For Threading Pipe in corners and ditches.

In ordering this style be careful to state Ratchet Plate, otherwise you might receive the ordinary kind.



No. 3—Ratchet Screw Plate threads and cuts 1, 1½, 1¾ and 2 inch Pipe.....	price	\$20.00	
" 4B " " " " " " 2½, 3, 3½ and 4 "	"	60.00	
" 5 " " " " " " 4½, 5 and 6 "	"	90.00	
Extra Dies, per set.....	No. 3—\$2.00	No. 4B—\$3.00	No. 5—\$6.00

UTTER

andles.

ily removed and

..... price \$14.00
 " 16.00
 " 20.00
 " 22.50
 " 35.00
 " 50.00
 " 75.00
 " 125.00

5 5A
 6.00 6.00
 0.00 0.60

ditches.

ce Ratchet Plate,
 binary kind.

..... price \$20.00
 " 60.00
 " 90.00
 No. 5—\$6.00

DUPLEX DIE STOCK

FOR PIPE

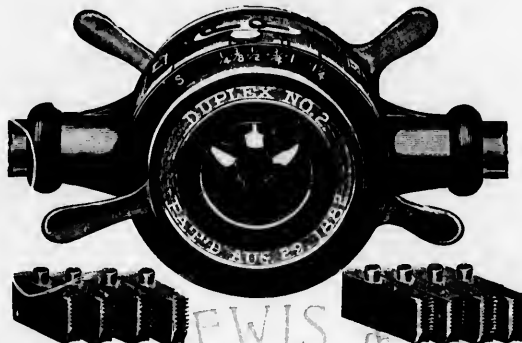

No turning back over the threads after it is once cut, is a prominent feature of the "Duplex."

All mechanics agree that the turning back against the cutting edge injures the Dies much more than the actual cutting. When the "Duplex" Dies become dull by cutting, they can readily be renewed by sharpening on a grindstone, thus making the life of these Dies longer, at least by four-fold, than any other made, and at the same time avoiding the common occurrence of stripping or weakening the thread, and rendering the work worthless.

The Cut-off is an adjustable attachment for cutting pipe, doing away with a pipe cutter, especially on large sizes, saving this extra tool.

No. 1 threading	Without Cut Off	With Cut Off
1/2, 3/4, 1, 1 1/4 inch pipe	\$13.00	\$16.00
2 " "	17.00	20.00
3 " "	22.00	25.00
3 1/2 " "	25.00	28.00
4 " "	40.00	45.00
5 " "	55.00	60.00

Prices of Extra Dies

No. 1 Per Single Set (4 pieces), right or left hand	Price
2 " " " " " "	\$2.40
3 " " " " " "	2.80
3 1/2 " " " " " "	3.20
4 " " " " " "	3.20
4 1/2 " " " " " "	5.00
5 " " " " " "	6.40
Extra Cut-off Knives, 1, 2, 3 and 3 1/2	each 0.80
" " " " 4 " 5	" 1.20

COMBINATION PIPE STOCK

With Loose Dies



Sizes and Prices

No. 00 cuts 1/2, 3/4 and 1 inch	each 8.00
" 0 " 1/2, 3/4 and 1 inch	" 9.00
" 0 Extra Dies, right or left, 1 1/2 inches square by 1/2 inch	" 1.00
" 0 " " " 2 1/2 " " " 1/2 "	" 1.50

RATCHET STOCKS

With Shield Covering Ratchet Wheel.



Price Without Dies

No. 1—Length 20 inch for Dies 2 1/2 x 2 1/2 x 1/2	each \$ 9.00
" 2— " 30 " " 4 x 4 x 1/2	" 13.00

These Ratchets will work either right or left hand.

SOLID DIE PLATES FOR PIPE



Nos. 0 to 1

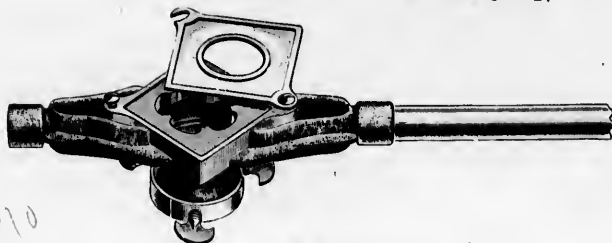

Nos. 2 and 3

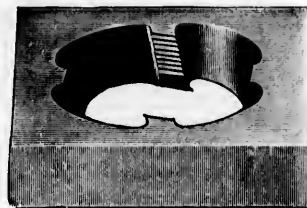

SOLID PIPE DIE

Numbers	0	1	1 1/4	1 1/2	2	3
Dies furnished with each Plate	1 to 1/2	1 to 1	1, 1 & 1 1/4	1, 1 1/4 & 1 1/2	1 1/4, 1 1/2 & 2	2 1/2 & 3
Dimensions of Dies	2 x 1/2	2 1/2 x 3/4	3 x 3/4	3 x 3/4	4 x 3/4	5 x 1 1/4
Die Plates with R. H. Dies complete	\$9.50	15.00	13.50	13.50	20.00	43.00
Die Plates without Dies	\$3.50	5.00	6.00	6.00	9.50	25.00
Extra Dies, Right or Left Hand	\$1.50	2.00	2.50	2.50	3.50	9.00
Extra Bushings	\$0.25	0.35	0.45	0.45	0.60	1.10
Die Frames	"	0.30	0.40	0.40	0.50	0.90

Nos. 2 and 3 have Leader Screws.

ARMSTRONG'S ADJUSTABLE STOCK AND DIES FOR THREADING IRON AND BRASS PIPE AND BOLTS

- No. 1 Stock, 4 Right Hand Pipe Dies, cutting 1/4, 1/2, 3/4 and 1 inch Pipe, complete in case \$ 9.00
- No. 2 Stock, 5 Right Hand Pipe Dies, cutting 1/2, 3/4, 1, 1 1/4 and 1 inch Pipe, complete in case 12.00
- No. 2 Stock, 7 Bolt Dies, cutting 1/2, 3/4, 1, 1 1/4 and 1 1/2 Bolts, complete in case 20.00
- No. 2 Stock, 5 Brass Pipe Dies, cutting 3/4, 1, 1 1/4 and 1 1/2 Pipe, complete in case 15.00

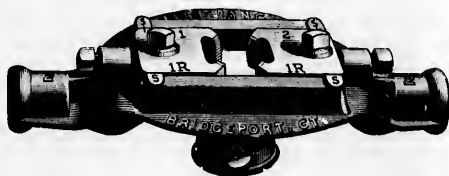

Prices of Separate Parts

No. 1 Stock, with Screws, Handle and Wrench, each	\$3.25	No. 2 Bolt Dies, Right or Left Hand, 1/2 to 1, each	\$2.00
" 2 " " " " " " " "	4.00	" 2 " " " " " " " " " 1 1/4 and 1 1/2 "	2.25
" 1 Pipe Dies, Right or Left Hand	1.25	" 2 Brass Pipe Dies, 3/4 to 1 1/2 "	2.00
" 2 " " " " " " " " "	1.50	" 2 Bushings	0.25

ARMSTRONG'S SECTIONAL STOCK AND DIES FOR PIPE

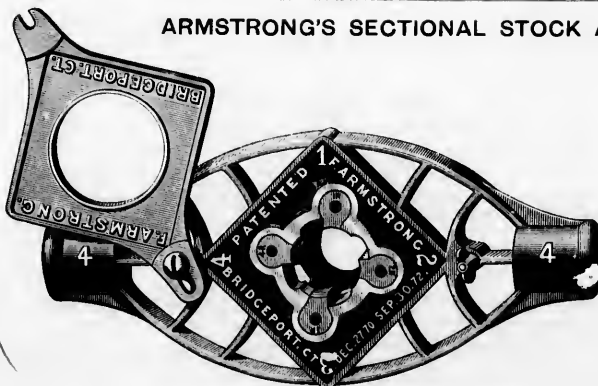

No.	Description	EACH
No. 4	Stock, 3 Dies, 1 1/2, 1 3/4 and 2 in.	\$18.00
" 4	" " " 1, 1 1/4, 1 1/2 and 2 in.	21.00
" 4	Blocks, with Cutter, right or left	3.00
" 4	Bushings	0.50
" 4	Cutters, right or left	0.50

PIPE CUTTERS

IMPROVED THREE-WHEEL PIPE CUTTER

No. 27



Nos.	1	2	3	4
Cuts Pipe.....	1/4 to 1 1/4	3/8 to 2	1 to 3 1/2	1 to 4 inch
Price.....each	\$4.50	6.00	10.00	15.00
Extra Cutters.....	\$0.25	0.30	0.40	0.50

IMPROVED ROLLER PIPE CUTTER

No. 29



Nos.	1	2	3	4
Cuts Pipe.....	1/4 to 1 1/4	1/2 to 2	1 1/2 to 3	2 to 4 inch.
Price.....each	\$4.50	6.75	10.00	20.00
Extra Cutters.....	\$0.25	0.30	0.40	0.50

SAUNDERS' ROLLER PIPE CUTTER



Nos.	1	2	3
Cuts Pipe.....	1/4 to 1	1 to 2	2 to 3 inch.
Price.....each	\$3.00	4.50	14.00
Extra Cutters.....	\$0.24	0.32	0.60

STANWOOD'S PIPE CUTTER



Nos.	1	2	3
Cuts Pipe.....	1/4 to 1	1 to 2	2 to 3 inch
Price.....each	\$2.25	3.40	10.50
Extra Cutters.....	\$0.20	0.30	0.40



E DIE

2	3
1 1/2 x 2	2 1/2 x 3
4 x 4	5 x 1 1/2
20.00	43.00
3.50	25.00
3.50	0.00
0.00	1.00
0.50	0.00



1/2 to 1, each	\$2.00
and 1 1/2	2.25
"	2.00
"	0.25



and 2 in. ...	EACH \$18.00
and 2 in. ...	21.00
right or left	3.00
.....	0.50
.....	0.50

PIPE TONGS

BROWN'S PATENT ADJUSTABLE PIPE TONGS

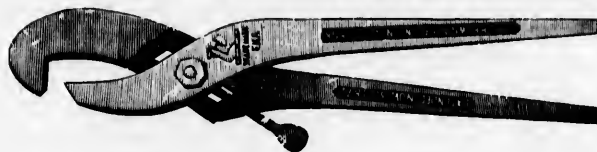

Nos.	1	1½	2	3	4
Takes Pipe	¼ to ¾	½ to 1	¾ to 1½	1 to 2	1½ to 3 inch.
Each	\$0.80	0.00	1.20	1.75	4.00

PATENT ADJUSTABLE PIPE TONGS

No. 25



Nos.	1	2	3
Takes Pipe	¼ to ¾	½ to 1½	¾ to 2½ inch.
Each	\$3.00	4.00	5.30

VULCAN CHAIN PIPE WRENCHES

Drop Forge from Bar Steel. All Parts are Interchangeable.



WRENCH WITH FLAT LINK CHAIN

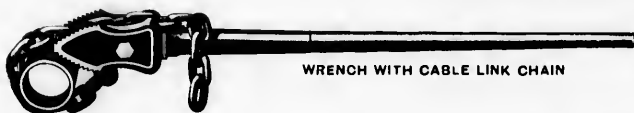

WRENCH WITH CABLE LINK CHAIN

Size, Nos.	10	11	12	13	13½	14	15
Capacity, Size of Pipe	¼ to ¾	¼ to 1½	½ to 2½	¾ to 4	1 to 6	1½ to 8	2 to 12 in
Length	13½	20	27	37	41½	50½	64½ "
Weight, pounds	1½	4½	8½	16	21	29	49
Price, with Flat Link	\$2.85	3.85	5.65	7.90	10.15	12.40	20.25
Price, with Cable Link	\$2.55	3.65	5.10	7.00	8.75	10.70	18.00
Extra Flat Link Chains	\$ 0.85	1.15	1.70	2.80	3.05	4.50	6.75
" Cable Link Chains	\$ 0.50	0.85	1.15	2.00	2.25	2.85	4.50
" Jaws, pair	\$ 1.15	2.00	3.10	4.50	5.35	6.20	8.45

When ordering, state if Flat or Cable Link Chain is wanted.

TRIMO CHAIN PIPE WRENCHES



Nos.	2	3	4	5
Each	\$6.00	8.00	10.00	15.00
Takes Pipe	¾ to 3	1 to 4	2 to 6	2½ to 10 inch.
Length	27	37	50	64 "
Extra Jaws, per pair	\$1.75	2.25	2.75	3.50

PIPE WRENCHES

ALLIGATOR WRENCHES

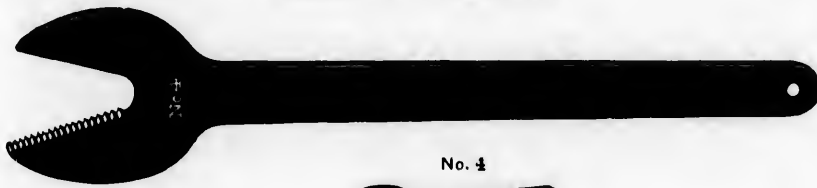

No. 1



POCKET

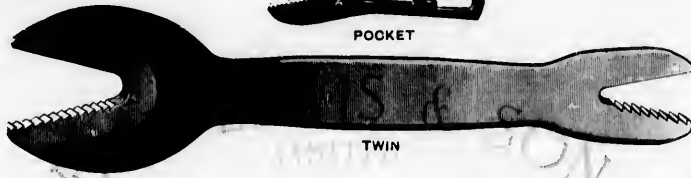

TWIN

Size No.	1	2	3	4	5	Twin	Pocket	
	1 to 2	2 to 3	3 to 4	4 to 5	5 to 6	6 to 7	1 to 2	2 to 3
Holds Pipe	1/2 to 1	3/4 to 1 1/4	1 to 1 1/2	1 1/2 to 2	2 to 3	1 to 1 1/2	1/4 to 1/2	1/4 to 1/2
Length	5 1/2	10	16	22	27	10	1	5 1/2
Each	\$0.35	1.00	2.00	3.00	4.50	1.50	0.35	0.45

4
1 1/2 to 3 inch.
4.00

3
1/2 to 2 1/2 inch.
5.30

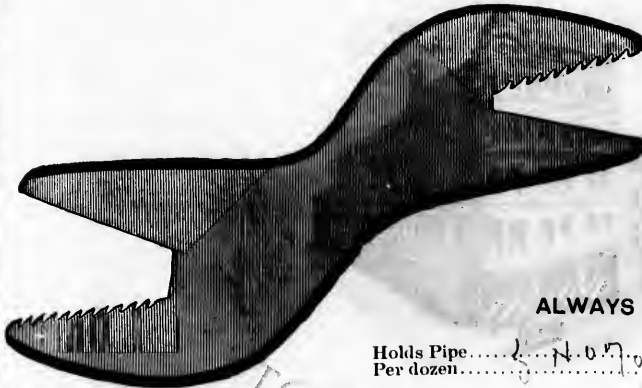

ALWAYS READY WRENCH

	No. 1	No. 2
Holds Pipe	1/2 to 3/4	1/2 to 1 1/2 inch.
Per dozen	\$5.75	7.75

THE CURTIS WRENCH

Length	9	15
Holds Pipe	1/4 to 3/4	1/2 to 1 1/2
Each	\$2.25	2.75

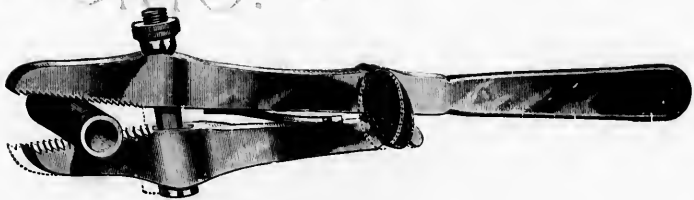

THE EAGLE WRENCH

Made of Drop Forged Steel and Malleable Iron, with Wood Handles.

No. 1—16 inch	takes Pipe 1/4 to 1 inch	each	\$3.50
No. 2—22 "	" " " 3/4 to 2 inch	"	0.50



5
15.00
2 1/2 to 10 inch.
04 "
3.50

PIPE WRENCHES

TRIMO PIPE WRENCHES



Length, Open.....	6	8	10	14	18	24	36	inch.
Holds Pipe.....	$\frac{1}{4}$ to $\frac{1}{2}$	$\frac{1}{2}$ to $\frac{3}{4}$	$\frac{3}{4}$ to 1	1 to $1\frac{1}{2}$	$1\frac{1}{2}$ to 2	2 to $2\frac{1}{2}$	$2\frac{1}{2}$ to 3	"
Each.....	\$2.00	2.00	2.25	3.00	4.00	6.00	12.00	
Jaws, each.....	\$0.75	0.75	0.85	1.15	1.50	2.25	4.50	

STILLSON PIPE WRENCHES



Length, Open.....	6	8	10	14	18	24	36	inch.
Holds Pipe.....	$\frac{1}{4}$ to $\frac{1}{2}$	$\frac{1}{2}$ to $\frac{3}{4}$	$\frac{3}{4}$ to 1	1 to $1\frac{1}{2}$	1 to 2	1 to $2\frac{1}{2}$	$\frac{3}{4}$ to $3\frac{1}{2}$	"
Each.....	\$2.00	2.00	2.25	3.00	4.00	6.00	12.00	
Jaws.....	\$0.75	0.75	0.85	1.15	1.50	2.25	4.50	

These Wrenches have wood handles from 6 to 14 inch. — 18 to 36 inch are all steel.

DONOHUE'S COMBINATION ENGINEERS' WRENCHES

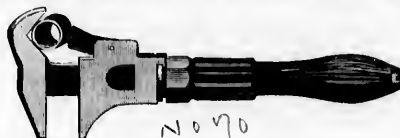

Long Sleeve Nut				Short Nut					
Size.....	10	12	15	inch.	Size.....	10	12	15	inch.
Holds Pipe.	$\frac{1}{2}$ to 1	$\frac{1}{2}$ to $1\frac{1}{2}$	$\frac{1}{2}$ to 2	"	Holds Pipe.	$\frac{1}{2}$ to 1	$\frac{1}{2}$ to $1\frac{1}{2}$	$\frac{1}{2}$ to 2	"
Each.....	\$2.40	2.70	3.80		Each.....	\$2.20	2.15	3.50	

TRIMO COMBINATION ENGINEERS' WRENCHES



Nos.....	1	2	3	
Holds Pipe.....	$\frac{1}{4}$ to 1	$\frac{1}{4}$ to $1\frac{1}{2}$	$\frac{1}{4}$ to 2	inch.
Each.....	\$2.40	2.70	3.85	

WRENCHES

BEMIS & CALL'S PIPE WRENCH No. 3

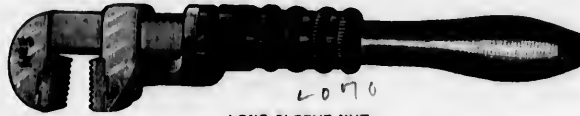

LONG SLEEVE NUT

Size.....	10	12	15 inch.
Holds Pipe.....	1 to 1 1/2	1 1/2 to 1 3/4	1 3/4 to 2 "
Price.....each	\$2.40	2.05	3.35

36 inch.
1/2 to 3/4
12.00
4.50

BEMIS & CALL'S COMBINATION PIPE WRENCH



LONG SLEEVE NUT

Size.....	10	12	15 inch.
Holds Pipe.....	1 to 1 1/2	1 1/2 to 1 3/4	1 3/4 to 2 "
Price.....each	\$2.40	2.70	3.80

36 inch.
1/2 to 3/4
12.00
4.50

WESTCOTT ADJUSTABLE WRENCH

No. 1—FOR BOLTS

No. 2—FOR PIPE



Size.....	8	10	12	14	inch.	Size.....	8	10	12	14	inch.
Opens.....	1	1 1/4	1 3/4	2	"	Holds pipe....	1 to 1 1/4	1 1/4 to 1 1/2	1 1/2 to 1 3/4	1 3/4 to 1 1/2	"
Per dozen.....	\$11.25	15.00	18.75	21.25		Per dozen.....	\$18.75	22.50	30.00	37.50	

15 inch.
1/2 to 2
3.50

ATWATER'S PIPE WRENCH JAW



Can be instantly attached to any ordinary Monkey Wrench.

No.....	1	2	3
Will fit Wrenches.....	0 and 8	10 to 18	15 to 21 inch.
Each.....	\$0.10	0.50	0.75
In Sets of one each, Nos. 1, 2, and 3 in a box.....			per set \$1.05

3 inch.
1/4 to 2
3.85

ADJUSTABLE POCKET WRENCHES



Drop Forged from Bar Steel. Finished in a thorough manner and case-hardened.

No. 1—1 inch Wrench, Nickel-Plated	per dozen	\$12.50
.. 2—1 " " " Black Finish	" "	11.25
.. 3—6 " " " "	" "	18.00

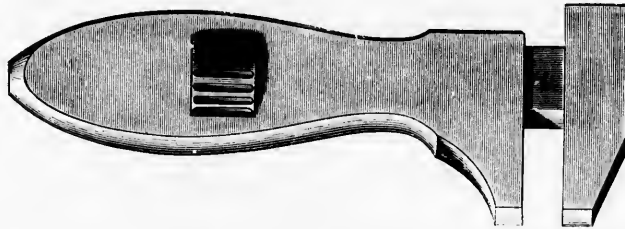

No. 22—1 inch Nickel-Plated Iron Pocket Wrench	per dozen	2.00
--	-----------	------

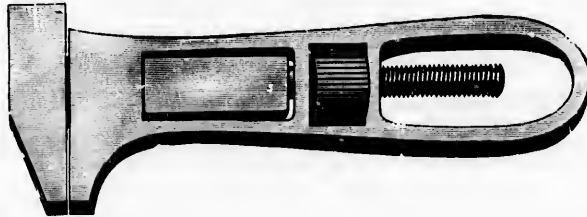

No. 1—1 inch Tinned Iron Pocket Wrench	per dozen	1.00
--	-----------	------

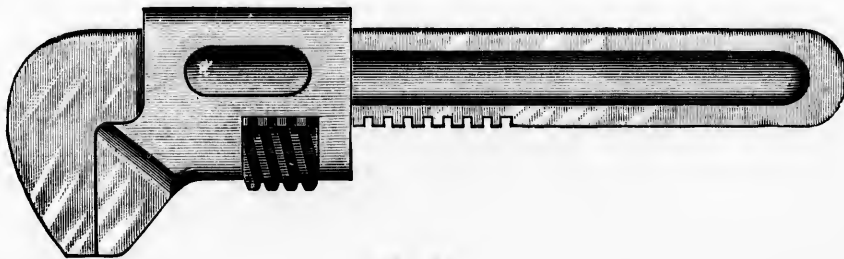

(Full Size)

No. 102—Nickel-Plated, Forged Steel Hardened Jaws	per dozen	4.00
---	-----------	------

Length
Black

Length
Black

Length
Black

Length
Black

SCREW WRENCHES

COE'S GENUINE SCREW WRENCHES



Improved Knife Handle, Reinforced Bar.

Length	6	8	10	12	15	18	21 inch.
Black ... per doz.	\$9.00	10.00	12.00	14.00	24.00	30.00	36.00

P. S. & W. SOLID HANDLE SCREW WRENCHES

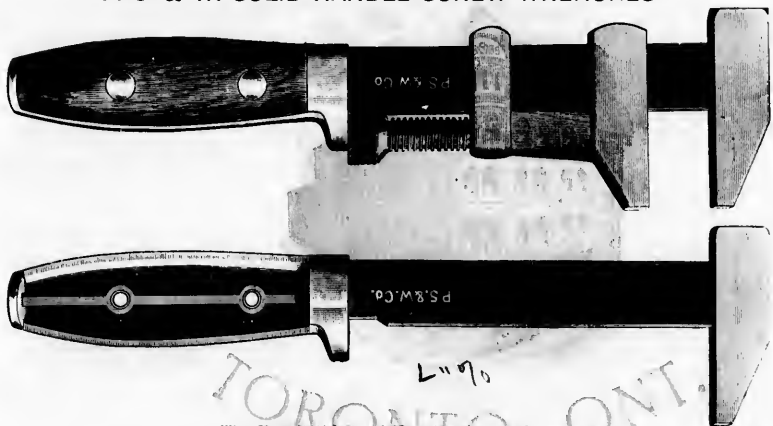

The Bar Solid Steel Forging in one Piece.

Size	6	8	10	12	15	18	21 inch.
Black ... per doz.	\$9.00	10.00	12.00	14.00	24.00	30.00	36.00

MACHINISTS' SCREW WRENCHES

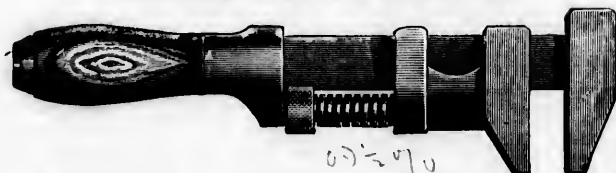

Length	6	8	10	12	15	18	21 inch.
Black ... per doz.	\$9.00	10.00	12.00	14.00	24.00	30.00	36.00

AGRICULTURAL WRENCHES

Length	6	8	10	12	15	18	21 inch.
Black ... per doz.	\$9.00	10.00	12.00	14.00	24.00	30.00	36.00

per dozen \$12.50
 " " 11.25
 " " 18.00

per dozen 2.00

per dozen 1.00

per dozen 4.00

ENGINEERS' WRENCHES

DROP FORGED STEEL

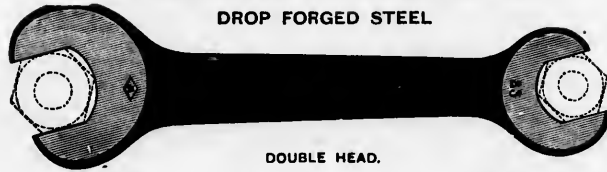

DOUBLE HEAD.

Number.	For Nuts, Inch. and	Opening Unfinished, Inch.	Opening Finished, Inch.	Extreme Length, Inch.	Thickness of Heads, Inch.	Unfinished, Each.	Finished, Each.
21	1/2	1/2	1/2	3 1/2	1/8	\$0.12	\$0.21
25	3/8	3/8	3/8	4 1/2	1/8	0.18	0.36
30	1/2	1/2	1/2	5 1/2	1/8	0.28	0.50
37	3/4	3/4	3/4	7 1/2	1/8	0.53	1.06
39	7/8	7/8	7/8	8 1/2	1/8	0.65	1.30
43	1	1	1	10 1/2	1/8	1.08	2.16
48	1 1/2	1 1/2	1 1/2	14 1/2	1/8	2.10	4.20

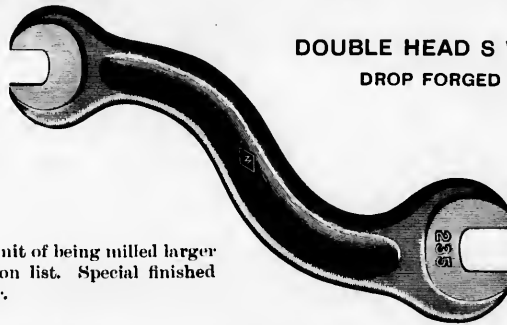

DOUBLE HEAD S WRENCHES

DROP FORGED STEEL

These Wrenches will admit of being milled larger than stock sizes as shown on list. Special finished sizes furnished only to order.

Number.	For Set Screws, Inch.	Square Head Cap Screws, Inch.	Hex. Head Cap Screws, Inch.	Opening Unfinished, Inch.	Opening Finished, Inch.	Extreme Length, Inch.	Thickness of Head, Inch.	Unfinished, Each.	Semi- finished, Each.	Finished, Each.
235	1/8	1/8	1/8	1/8	1/8	3 1/2	1/16	\$0.10	\$0.15	\$0.20
242	1/4	1/4	1/4	1/4	1/4	4 1/2	1/16	0.15	0.22	0.30
251	3/8	3/8	3/8	3/8	3/8	6 1/2	1/16	0.21	0.31	0.42
263	1/2	1/2	1/2	1/2	1/2	8	1/16	0.28	0.42	0.50
277	3/4	3/4	3/4	3/4	3/4	10	1/16	0.37	0.55	0.74



SINGLE HEAD

Number.	For Nuts, Inch.	Opening Unfinished, Inch.	Opening Finished, Inch.	Extreme Length, Inch.	Thickness of Heads, Inch.	Unfinished, Each.	Finished, Each.
00	1/8	1/8	1/8	2 1/2	1/16	\$0.08	\$0.16
0	1/4	1/4	1/4	2 1/2	1/16	0.09	0.18
1	3/8	3/8	3/8	3 1/2	1/16	0.10	0.20
2	1/2	1/2	1/2	4 1/2	1/16	0.12	0.24
3	3/4	3/4	3/4	5 1/2	1/16	0.14	0.28
4	7/8	7/8	7/8	6 1/2	1/16	0.17	0.34
5	1	1	1	7 1/2	1/16	0.20	0.40
7	1 1/8	1 1/8	1 1/8	9 1/2	1/16	0.32	0.64
8	1 1/4	1 1/4	1 1/4	11 1/2	1/16	0.40	0.80
9	1 3/8	1 3/8	1 3/8	13	1/16	0.50	1.00
10	1 1/2	1 1/2	1 1/2	14 1/2	1/16	0.65	1.30
11	1 3/4	1 3/4	1 3/4	16 1/2	1/16	0.85	1.70
12	2	2	2	18 1/2	1/16	1.10	2.20
14	2 1/2	2 1/2	2 1/2	22 1/2	1/16	1.75	3.50

When ordering, please state whether Unfinished or Finished Wrenches are wanted.

BAXTER "S" WRENCHES

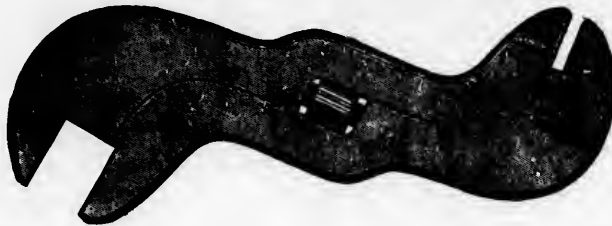

Length	6	8	10 inch.
Per dozen.....	\$6.00	9.00	12.00

IMPROVED COMBINATION PLIERS



Gas Pliers, Wire Cutters, Wrench and Screw Driver combined.

No. 22—B. & S. 6 inch Combination Pliers, Drop Forged, Black	per dozen	\$20.25
" 23— " 6 " " " " " Plated	" "	22.50
" 2041—Bokers' 6 " " " " " " "	" "	18.40



No. 24—B. & S. 10 inch Combination Pliers, Drop Forged, Black	per dozen	\$27.00
" 25— " 10 " " " " " Plated	" "	31.50

GAS BURNER PLIERS



No. 26—5 inch Gas Pliers, Open Throat, Parallel Jaws, Plated.....	per dozen	\$12.00
" 27—7 " " " " " " "	" "	16.80



No. 1349



No. 853C

No. 1349—5 inch Bright.....	per dozen	\$5.00
No. 853C—5½ inch Bright.....	per dozen	\$4.15

Finished. Each. \$0.21
2.....
8..... 0.36
28..... 0.56
33..... 1.06
35..... 1.30
38..... 2.16
0..... 4.20

HES

Semi-finished. Each. \$0.15	Finished. Each. \$0.20
0.22	0.30
0.31	0.42
0.42	0.56
0.55	0.74

Finished. Each. \$0.16
0.18
0.21
0.24
0.28
0.34
0.40
0.64
0.80
1.00
1.30
1.70
2.20
3.50

GAS BURNER PLIERS



No. 161

No. 161—5 inch Polished, Solid Cast Steel, Oil Temperedper dozen \$4.70
 " 161-6 " " " " " " 6.25

GAS PLIERS

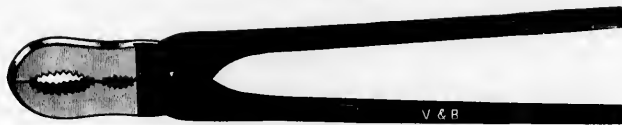

No. 162

Solid Cast Steel, Polished, Oil Tempered.

Size	7	8	10	inch.
No. 162	\$5.75	6.50	8.35	

WYNN'S GAS PLIERS



No. 697

Size	6	8	10	12 inch.
No. 697	\$5.95	8.25	12.00	15.50

MINERS' FUSE CAPPING PLIERS

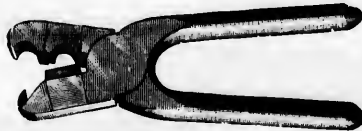

For cutting or sizing the fuse, crimping the cap and making the hole in cartridge for the cap.

No. 5—Nickel-Plated, weight 2 ouncesper dozen \$11.25

BERNARD PLIERS

OPEN THROAT, PARALLEL JAWS

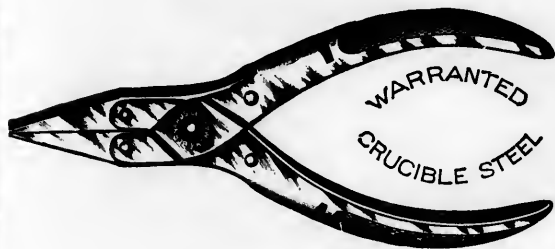

FLAT NOSE

Size.....	3½	4	4½	5	inch.
Jewellers', Plated..	\$10.50	11.90	13.30	14.70	doz.
Size.....	4½	5½	6½	7½	inch.
Extra Heavy, Plated	\$9.80	12.60	15.40	21.00	doz.

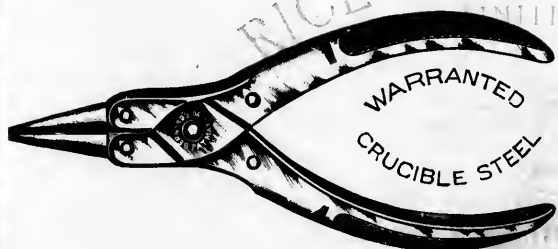

ROUND NOSE

Size.....	4	4½	inch.	
Jewellers', Plated.....	\$11.90	13.30	doz.	
Size.....	4½	5½	6½	inch.
Extra Heavy, Plated	\$9.80	12.60	15.40	doz.

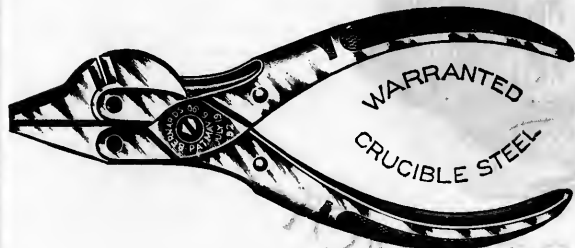

CUTTING

Size.....	5	inch.			
Jewellers', Plated.....	\$21.00	doz.			
Size.....	4½	5½	6½	7½	inch.
Extra Heavy, Plated	\$17.50	20.30	24.50	33.60	doz.

FLAT NOSE, HOLLOW JAW PARALLEL PLIERS



PARAGON



LODI

Size.....	4	4½	5	5½	6	inch.
No. 50-Paragon, Plated.....	\$3.10	3.55	4.05	4.60	5.10	
" 60-Lodi, Bright.....	1.35	1.60	1.80	2.05	2.25	

per dozen \$4.70
" 6.25

10 inch.
8.35

12 inch.
15.50

cap.
per dozen \$11.25

LINEMEN'S CUTTING PLIERS



With Rubber Handles, Open Throat Parallel Jaws.

No. 40—8 inch Electric Cutting Pliers, with Rubber Handles.....	per doz, \$12.00
“ 39—8 inch Linemen's “ without “ “	“ 36.00

SPLICING CLAMPS

FOR ELECTRICIANS



No. 1—Black Japanned, for 4, 6, 8 or 9 gauge Wire.....	per doz, \$22.50
“ 2—Polished Head, “ 4, 6, 8 “ 9 “ “	“ 28.00
“ 3—Full Polished, “ 4, 6, 8 “ 9 “ “	“ 30.00

SEWING MACHINE PLIERS

WITH BELT PUNCH

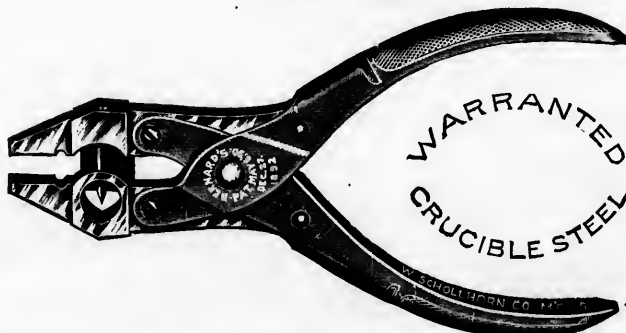

For cutting and piercing round leather belting up to ¼ inch diameter.

No. 41—5½ inch.....	per doz, \$16.80
---------------------	------------------

CUTTING NIPPERS

HALL'S PATENT COMPOUND LEVER CUTTING NIPPERS

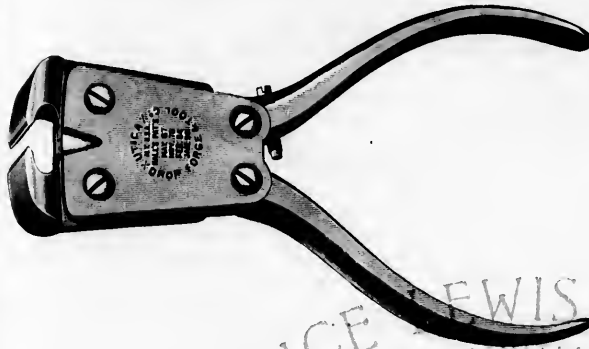

ALL PARTS INTERCHANGEABLE

Front Cutting Nippers

No. 1	4 in. cuts	$\frac{1}{8}$ in. wire	per doz.	\$12.00
" 2	5 " "	$\frac{3}{16}$ " "	" "	13.50
" 4	7 " "	$\frac{1}{4}$ " "	" "	21.00
" 6	8 " "	$\frac{5}{16}$ " "	" "	24.00
" 9	11 " "	$\frac{3}{8}$ " "	" "	27.00

EXTRA PARTS

	Jaws. Per Single Dozen.	Handles. Per Single Dozen.
No. 1	\$3.00	\$3.00
" 2	3.00	3.00
" 4	4.00	4.00
" 6	5.00	5.00
" 9	5.00	6.00

Extra Screws, Nos. 1 to 4. . . . per doz. \$1.20
 Springs, all sizes " 0.85

per doz, \$42.00
 " " 30.00

STARRETT'S CUTTING NIPPERS

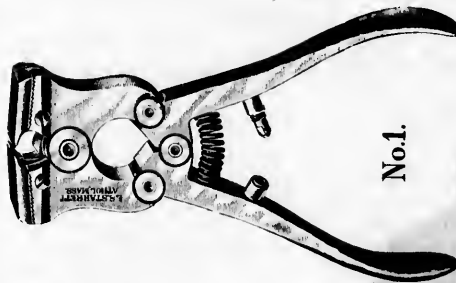

No. 1.

B—For Bicycle use.



M—For Music Wire.



C—For common use.



No. 1—5 $\frac{1}{2}$ in. Adjustable Jaw Cutting Nippers,	per pair	\$3.40
" 2—7 " "	" "	4.25

Extra Jaws, either B, M, or C, which should be designated per pair 0.85

Unless otherwise ordered, Cutting Nippers with C Jaws will be sent.

per doz, \$22.50
 " " 28.00
 " " 30.00



IMPROVED CUTTING NIPPERS

No. 0	14 in. long, 2 in. Jaws, very strong	each	\$4.25
" 1	12 in. long	" "	2.00
" 3	10 in. long	" "	1.75

BUTTON'S WIRE CUTTER AND PLIERS, COMBINED

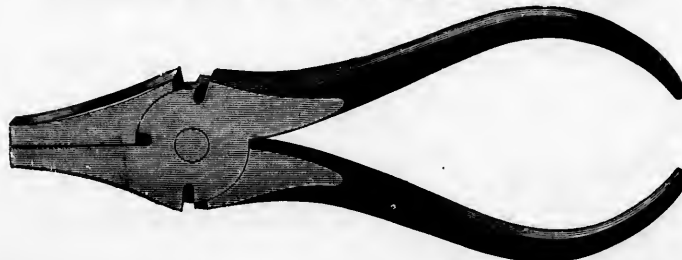

Size	6	8	9	10	12	inch.
American		\$9.20		11.00		
No. 1319B—Bokers	\$3.00	4.20	4.50	5.20	7.40	
" 4042—German	3.90	4.75	5.15	5.85		

per doz. \$16.80

PLIERS

SIDE CUTTING PLIERS



Length.....		4½	5	5½	6	6½	7	8	9 in
No. 153—Stubs' Side Cutting.....	per doz.	\$11.20	11.20	11.20	12.35	15.05	21.15	20.85	33.00
" 1313A—Boker's "	"		5.50		7.00	7.75	8.75		
" 1313AY— " "	"		9.00	9.50	10.30	11.25	12.00		

FACE CUTTING PLIERS



No. 154



No. 285 A

Length		5	5½	6	7	8	9	10 in.
No. 154—Stubs' Face Cutting.....	per doz.	\$11.75	12.00	15.70				
" 1306A—Boker's "	"		5.75	6.35	7.45			
" 477—Wynn's "	"		8.80	10.25	12.25			
" 285A—Stubs' heavy "	"				10.16	11.80	13.50	17.75 19.00

ANGLE CUTTING PLIERS



Length		5	5½	6 in.
No. 149—Stubs' Angle Cutting....	per doz.	\$11.75	12.00	15.70

FLAT NOSE PLIERS



Length	3½	4	4½	5	5½	6	6½	7 in.
No. 161—Stubs', per doz.	\$6.15	6.15	6.15	6.75	7.85	10.10	13.45	15.70 22.50
" 98—Yeoman's "		2.50	2.50	2.50	2.80	3.20	3.80	4.50
" 1337A—Boker's "		0.85	1.00	1.10	1.20	1.30		

ROUND NOSE PLIERS



Length	3½&4	4½	5	5½	6	6½	7	8 in.
No. 162—Stubs', per doz.	\$6.15	6.15	6.75	7.85	10.10	13.45	15.70	22.50
" 99—Yeoman's "		2.50	2.50	2.50	2.80	3.20	3.80	4.50
" 1336A—Boker's "		0.85	1.00	1.10	1.20	1.30		

STOCKINGER'S PLIERS



Length.....		5½	5½ in.
No. 156—Stubs'.....	per doz.		\$9.00
" 1283—Boker's.....	"	\$6.00	
" 163—Stubs' Pendulum Pliers.....	"	7.85	

TINNERS' SHEARS

BENCH SHEARS



No. 4—Cuts 8 inches	each	\$7.00
" 5— " 7 "	"	5.00
" 6— " 6 "	"	5.00

TINNERS' HAND SHEARS

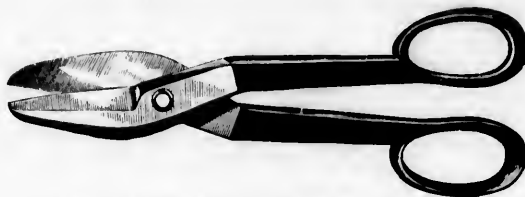

PECK, STOW & WILCOX STRAIGHT CUT

Nos.	6 $\frac{1}{2}$	7	8	9
Length of cut.....	4 $\frac{1}{2}$	5	5 $\frac{3}{4}$	6 inch.
Price	\$3.75	3.15	2.50	1.90

HEINISCH'S STRAIGHT CUT

Nos.	7	8	9	10
Length of cut.....	4	4 $\frac{1}{2}$	5	5 $\frac{1}{2}$ inch.
Price	\$2.75	2.20	1.65	1.55

JEWELLERS' Steel Laid Hand Shears, Nickelled, 1 $\frac{1}{2}$ inch cut.....	per dozen	\$16.80
" " " " Japanned 1 $\frac{1}{2}$ "	"	14.00



CIRCULAR CUT

Nos.	8	9
Length of cut	3 $\frac{1}{2}$	3 inch.
Peck, Stow & Wilcox	\$3.75	3.15
Heinisch's	\$3.50	2.75



AJAX TINNERS' SHEARS

Length over all....	10 $\frac{1}{2}$	11 $\frac{1}{2}$	12 inch.
Length of cut	2 $\frac{1}{2}$	2 $\frac{1}{2}$	3 "
Price,....per dozen	\$12.00	15.00	18.00



GERMAN SNIPS

No. 112A

Length over all	8	9 inch.
Price	\$7.00	8.00

GASOLINE HEATERS AND TORCHES



No. 1—HELPER

Single Burner, Swivel Mounted, removing Hood.
The Tank is made of Heavy Sheet Brass.

Priceeach \$8.00



No. 2—HELPER

Double Burner, Swivel Mounted, removing Hood.
The Tank is made of Heavy Sheet Brass.

Priceeach \$11.75

..... each \$7.00
..... " 5.00
..... " 5.00

9
3 inch.
1.00

10
2 1/2 inch.
1.55

dozen \$16.80
" 14.00



PERFECTION TORCH

The Burner is made of Brass and has a strong
Generator, holds about one quart.

Priceeach \$5.15



ELECTRICAL FORGE

Suitable for Electricians and Bicycle makers.

Priceeach \$7.85

9
3 inch.
3.15
2.75

9 inch.
8.00

EWIS &
LIMITED

TORONTO, ONT.

GASOLINE HEATERS AND TORCHES



Diamond Torch, holds about a half pint of Gasoline each \$4.00

ELECTRIC BLOW TORCH

Weight, two pounds when empty, three pounds when filled,
 specially adapted for Linemen and General Electricians.
 Price each \$5.40



ELECTRIC BLOW TORCH



COMBINATION BLOW TORCH

COMBINATION BLOW TORCH

A combined Brazier, Soldering-Iron Heater, and Blow
 Torch. Price each \$7.00

GASOLINE HEATERS AND TORCHES



IMPERIAL BLOW TORCH

Holds three pints. Burns about four hours
with one filling and pumping.

Price.....each \$6.00



BRAZIER'S BLOW TORCH

Holds three pints. Burns about four hours
with one filling and pumping.

Price.....each \$7.00

EUREKA BRAZER



**NO COAL DUST
OR ASHES**

**NO HEAT
WHEN NOT IN USE**

The great advantage that this machine possesses over others is that the burners are mounted on SWIVEL JOINTS, thus enabling the operator to adjust them in such a manner that the flames will meet where the heat is required upon the work to suit the operator. The tank is made of heavy galvanized iron and strong enough to stand any air pressure which is required to get good results from the flames. The air gauge is so placed that the operator can always see the amount of pressure there is on the tank, as it requires from 15 to 20 pounds to do good brazing.....Price, without pump \$30.00

SOLDERING COPPERS



Nos.....	00	0	1	2	3	4
Weight lbs.each	$\frac{1}{2}$	$\frac{3}{4}$	1	1 $\frac{1}{2}$	2	2 $\frac{1}{2}$
Price, without handle	\$0.20	0.30	0.40	0.55	0.70	0.90

SOLDERING SETS



No. 2

In Wooden Boxes containing Soldering Iron, Bar of Solder, Box of Resin.

No. 1 -Adapted for attaching to gas burner	per dozen sets	\$10.80
" 2 -Not adapted to gas burners.....	" "	10.90



No. 3

No. 3 -Containing Soldering Iron, Bar of Solder and Box of Resin	per dozen sets	\$5.25
--	----------------	--------

LEAD LADLES



Diameter.....	3	3 $\frac{1}{2}$	4	5	6	8	inch.
Wrought Iron	per dozen	\$1.70	2.00	2.45	3.75	5.20	11.50
Long Handle, Galvanized Potash Ladles, 10 inch diameter.....	per dozen	\$24.15					
" " " " " " " " " " " "	" "	18.65					



Cast Iron, with Wood Handle, Wrought Shank.

No. 1 -2 inch diameter	per dozen	\$1.75
" 2 -2 $\frac{1}{2}$ " "	" "	2.15

KEYSTONE COMBINATION RATCHET

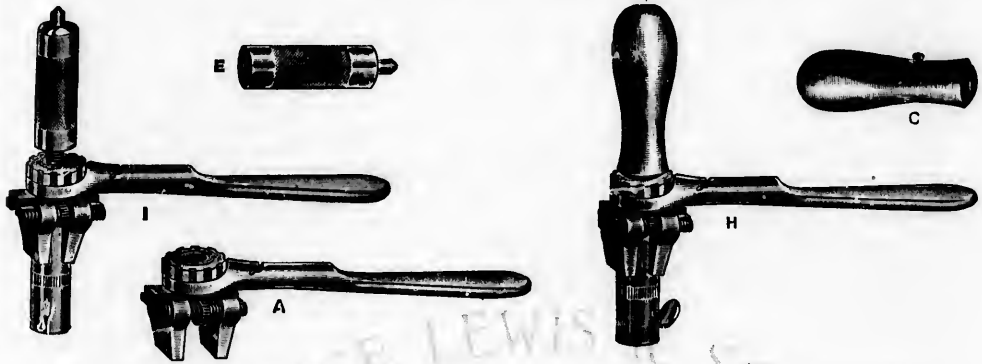

Combination No. 1 includes Wrench (Fig. A); Bit Holder with wood handle, as in Fig. H; Drill Socket, (either Square or Morse Taper), with Feed Nut, (Fig. E). Combination No. 1, complete..... \$5.00
 Wrench (9-inch handle, square jaws)..... each 2.50
 Bit Holder..... " 1.00
 Drill Socket, with Feed Nut..... " 1.50

KEYSTONE RATCHET DRILL REVERSIBLE

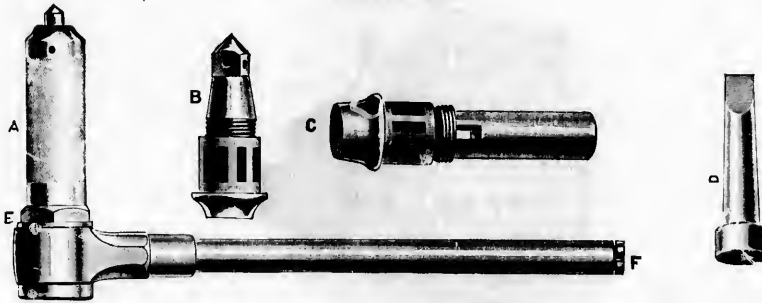

This illustration shows Ratchet Drill adjusted for Morse No. 2 Taper Shank Drills. Cut C represents Morse Taper Socket. Cut D, Square Socket to fit Morse Taper Socket. Cut B, Boiler-makers' Drill for Square Shank Drill. E indicates the knob for reversing the movement of Ratchet.

No.	1	2	3
Length.....	10	14	18 inch.
Ratchet, with Morse Taper Socket.....	\$5.25	0.00	0.75
Boiler-makers' Ratchet with Short Feed.....	\$5.00	5.75	0.50
Square Shank, Sleeve Separate.....	\$1.00	1.25	1.25
Socket for Boiler makers' Drill and Feed Screw.....	\$1.50	1.75	2.00

N.B. - All Drill Sockets Interchangeable with Holder.

SMITH'S PATENT FRICTION RATCHET

No Lost Motion. Instantaneous Clutch.

Will work successfully in places so contracted that a Ratchet is entirely useless.

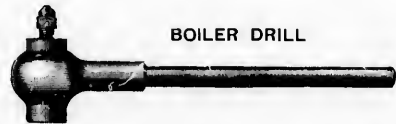
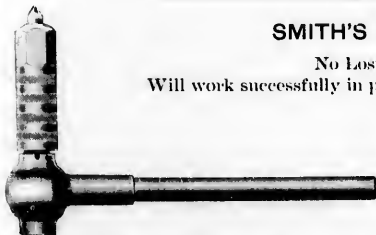

No. 1—12-inch Handle, includes Wrench, made for Square or Round Shank Drills..... each \$8.25
 " 2—10 " " Boiler Drill for Square Shank Drills..... " 6.50

RATCHET DRILLS

WESTON'S DIFFERENTIAL RATCHETS

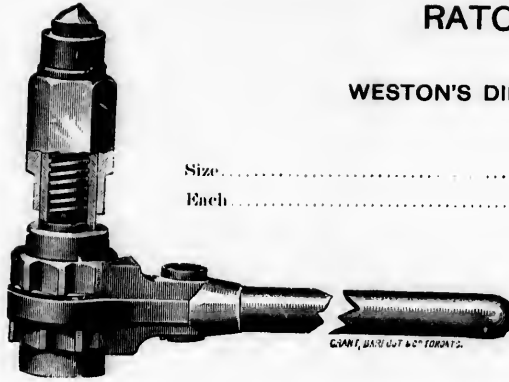

Size	12	14	16 inch.
Each	\$5.25	5.70	6.15

No. 01B RATCHETS

Size	12	14	16	18 inch.
Each	\$3.85	4.50	5.15	5.80

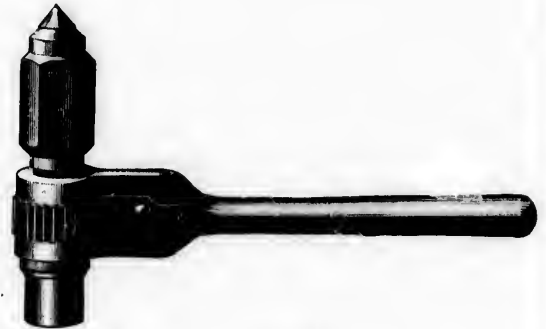

No. 01B

No. 74½ RATCHETS

Have Round Sleeve, instead of Hexagon
as in No. 01B.

Size	12	14	16	18 inch.
Each	\$3.30	3.75	4.25	5.75

RATCHET HAND DRILLING MACHINE

This machine will bore holes at any angle within an outside diameter of 14 inches, or inside diameter of 9½ inches. There is a ratchet on the end of the Spindle, and another on mitre wheel shaft. The crank is used on the one that is most convenient. The Feed Screw traverses 2½ inches. The Spindle is made to fit ½ inch Shank Twist Drills. Weight, 40 lbs. each \$20.50

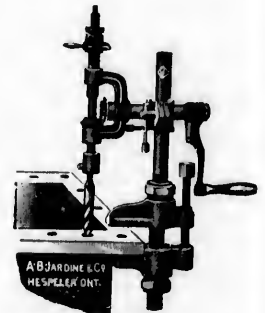

BREAST DRILLS

16 inch.
6.15

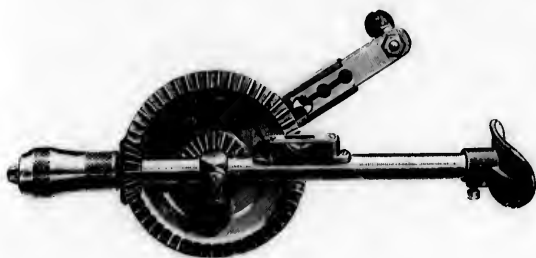

No. 10

BALL BEARING - Nickel Plated Stock and Chuck, will hold both round and square Shank Drills. The Gears are cut, and are changeable from even to 3 to 1. Price,.....each \$1.05



No. 12

BALL BEARING - Changeable Gear from even to 3 to 1. 5-inch Drive Wheel, has new alligator jaw, suitable for round or square Shank Drills. Price, each.....\$1.15



No. 13

BALL BEARING Has 6-inch Drive Wheel, giving speed $4\frac{1}{2}$ to 1. Double geared. Nickel-Plated Stock and Chuck. Price,.....each \$6.00

HAND DRILL



No. 2

BALL BEARING It has cut gears and an adjustable friction roll to prevent gears from springing out of engagement. The cut shows an extra handle, to be attached when it is desired for use in manner of a breast drill. The Chuck holds from 9 to 17-01. Price, with 8 fluted pointseach \$1.15

HAND DRILLS



GOODELL'S
AUTOMATIC DRILLS.

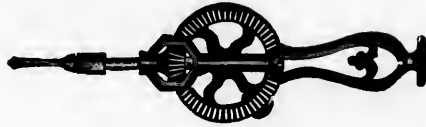

No. 4

This Drill Stock is eight inches in length, and weighs eight ounces. It is made of iron, with rosewood handle and Chuck for holding the Drill Points. This Chuck is made on a new plan, and it centers and holds the Drill perfectly. A box containing six superior Drill Points, of various sizes, with each Drill.

No. 4—Stock and Drills each \$0.85
Extra Drill Points per set (6), $\frac{3}{32}$ to $\frac{1}{16}$ inch " 0.30

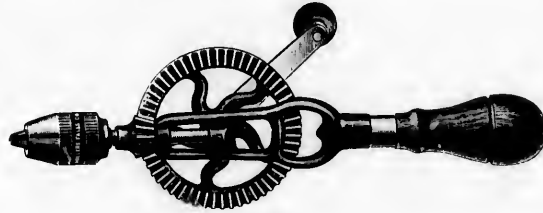

No. 1

These Drills are now made with three jaws, resting in solid sockets, and there are no springs to get out of place or out of order. The Chucks are nicked and the Handles cocobola. They hold Drills from 0 to $\frac{1}{8}$ inch.

An extra handle, as shown with No. 2, is now furnished with this Drill.

No. 1—Including 8 Fluted Points in hollow handle each 2.10

BALL-BEARING DRILL BRACE

NICKEL-PLATED WITH ROSEWOOD HANDLE AND LIGNUM-VITÆ HEAD.

No. 25

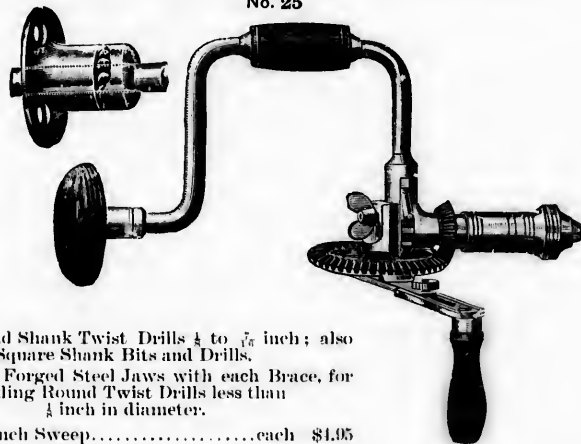

Holds Round Shank Twist Drills $\frac{1}{4}$ to $\frac{1}{8}$ inch; also Square Shank Bits and Drills.

Extra set of Forged Steel Jaws with each Brace, for holding Round Twist Drills less than $\frac{1}{4}$ inch in diameter.

No. 25—10 inch Sweep each \$1.95

GOODELL'S AUTOMATIC DRILLS

The Drill Points are contained in the handle, each in a separate compartment and the exact location of each size is seen at a glance. These tools are made of hollow brass, nickel-plated, packed one in a box.

Price, each, with 8 Drill Points \$2.75
Extra Drill Points, per set (8) 0.85

BARKER'S IMPROVED RATCHET BRACES

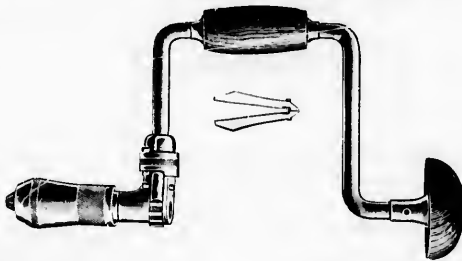

Polished Steel Sweep, Stained Hardwood Head and Handle.

No. 110—10 inch Sweep.....	per doz.	\$11.00
" 112—12 " "	"	12.50

Nickel-Plated Steel Sweep, Cherry Handle and Head.

No. 610—10 inch Sweep.....	per doz.	\$18.15
" 612—12 " "	"	18.75

BARKER'S IMPROVED BRACES

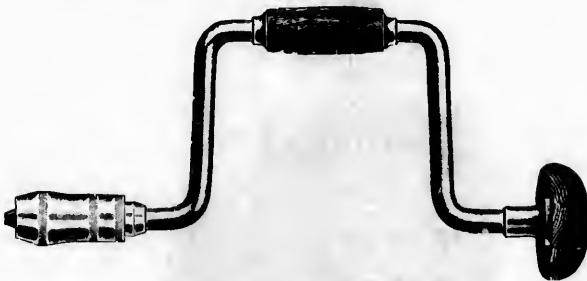

Plain, with short Sleeve Chuck.

	Per doz.	
No. 1108—8 inch Sweep.....	\$5.65	
" 1110—10 " "	6.25	

Polished Steel Sweep, Walnut Head and Handle.

	Per doz.	
No. 1308—8 inch Sweep.....	\$6.25	
" 1310—10 " "	6.90	
" 1312—12 " "	7.50	

Nickel-Plated Steel Sweep, Rosewood Head and Handle.

	Per doz.	
No. 1608—8 inch Sweep.....	\$11.25	
" 1610—10 " "	11.90	
" 1612—12 " "	12.50	

SPOFFORD'S BRACES

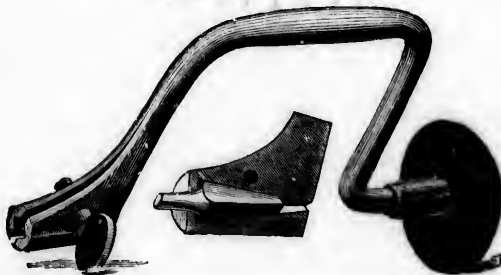

Iron Head.

No. S 8—8 inch Sweep.....	per doz.	\$19.00
" S 10—10 " "	"	22.00
" S 12—12 " "	"	25.00

Wood Head and Handle, Nickel-Plated.

No. S 108—8 inch Sweep.....	per doz.	\$24.00
" S 110—10 " "	"	27.00
" S 112—12 " "	"	30.00

BARBER'S IMPROVED BRACES

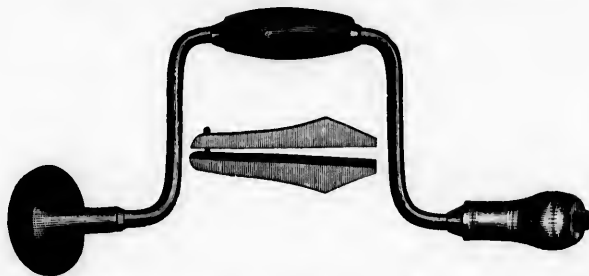

Polished Steel Sweep, Ebonized Head and Handle, Steel Quill with Anti-friction Steel Collar.

No. 23 — 8 inch Sweep	per doz.	\$7.75	RATCHET BRACES	
" 22 —10 "	"	8.90	No. 123 — 8 inch Sweep	per doz. \$16.80
" 21 —12 "	"	10.10	" 122 —10 "	" 18.00

BARBER'S IMPROVED BALL-BEARING BRACES

Nickel-Plated Steel Sweep, Rosewood Handle with inserted Brass Rings. The Chuck has a hardened steel anti-friction washer between the two sockets. The Head has a bearing of steel balls, running on hardened steel plates. Jaws are forged steel.

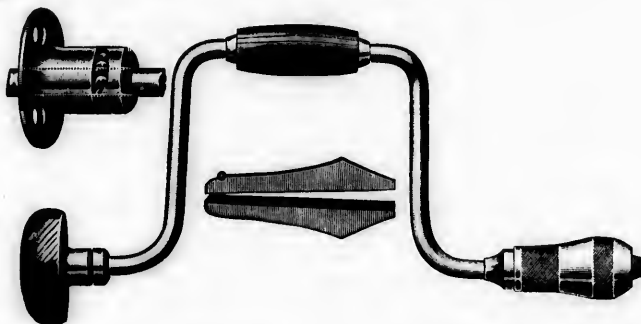

No. 15 —4 inch Sweep	per doz.	\$20.00	No. 12 —10 inch Sweep	per doz. \$27.00
" 14 —6 "	"	21.00	" 11 —12 "	" 30.00
" 13 —8 "	"	24.00	" 10 —14 "	" 33.00

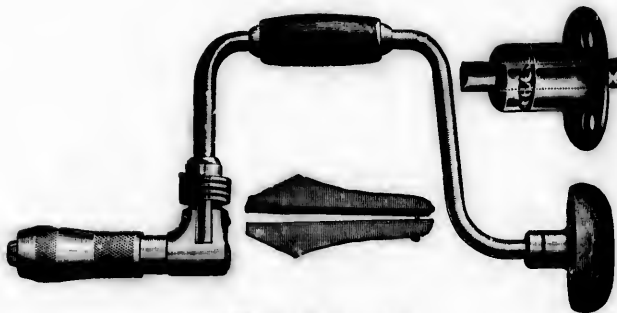

RATCHET BRACES

No. 32 —10 inch Sweep	per doz.	\$36.00
" 31 —12 "	"	39.00

P. S. & W. PATENT ADJUSTABLE BRACES

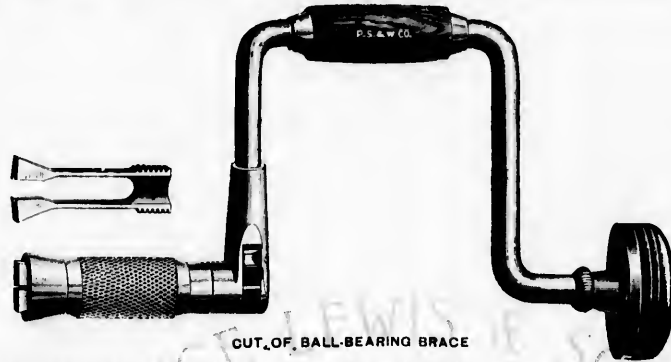

CUT OF BALL-BEARING BRACE

RATCHET BRACE

No. 0104	— 6 inch Sweep per doz.	\$26.25
" 0103	— 8 " "	28.15
" 0102	— 10 " "	30.45
" 0101	— 12 " "	32.75
" 0100	— 14 " "	37.75
" 92	— 10 inch Sweep, without Ratchet. "	23.50

BALL-BEARING RATCHET BRACE

No. 1003	— 8 inch Sweep per doz.	\$20.40
" 1002	— 10 " "	31.00
" 1001	— 12 " "	31.00
" 1000	— 14 " "	39.00

Half dozen in a package.

WITH BALL-BEARING HEAD, FITTED WITH SAMSON BALL-BEARING CHUCK

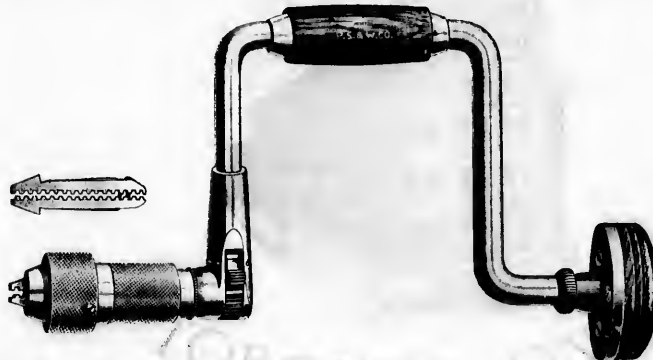

Nickel-plated Steel Sweep, Lignum-vita Heads, Rosewood Centers.

These Braces are finely finished and accurately fitted in every part. The sleeve of the chuck is drilled through solid cast steel. The jaws open parallel or at a slight angle; are interlocking, and grip firmly either round, tapering or square shanks the entire length of the jaw, so that square shanks will not slip and round or tapering shanks will not turn or twist.

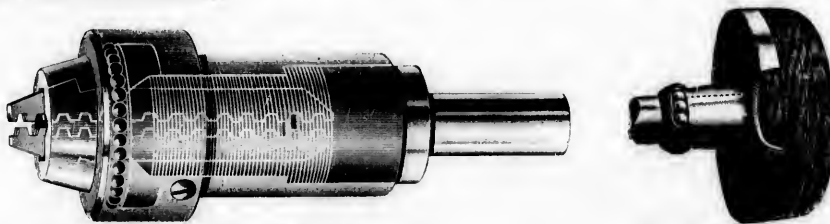

Samson Chuck used in Brace.

Ball-Bearing Head.

No. 1202	— 10 inch Sweep Ratchet Brace per doz.	\$37.00
" 1201	— 12 " "	30.20

Packed in hinged wooden boxes, half dozen in a box.

ANGULAR BIT STOCKS AND BRACES

ANGULAR BIT STOCK



No. 35each \$2.25

CORNER BRACE



Full Nickel-Plated, Cocobola Head
and Handles.

No. A8—8 inch Sweepeach \$1.15
 " A10—10 " " " 4.00

MILLER'S FALLS BORING MACHINE

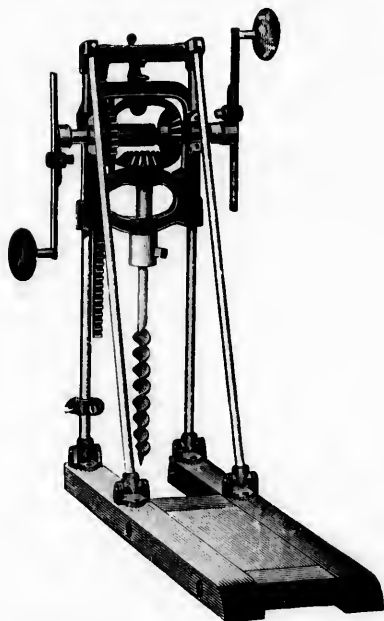

In this machine the frame is made of half-inch round steel rods ; the braces are the same, and attached to the rods at the top by a set screw. When this set screw is loosened the frame falls over, so as to bore at any desired angle.

The depth of the hole to be bored is fixed by a stop, as seen on the left-hand upright rod in the cut. When the frame strikes this stop, lift the latch and the machine throws itself into gear by the use of a spring, and the Auger is lifted out of the hole by continuing to turn the crank in the same direction.

When the Auger is drawn from the hole, the frame hangs itself up until the machine is moved to the next hole ; then it is dropped down by turning the crank back until the Auger strikes the wood, when it is thrown out of gear, and proceeds to bore the next hole. As seen in the cut, the machine has adjustable cranks, which fully regulate its speed and power.

Machine without Auger.....each \$12.35

CARPENTERS' BORING MACHINES

WITH HARDWOOD FRAME AND BASE

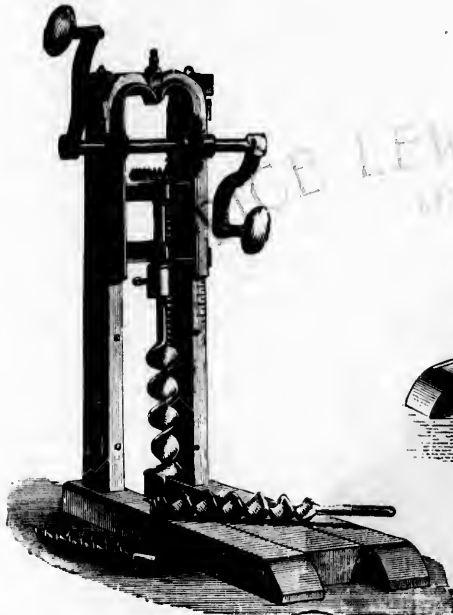

Style Nos. 1 and 3

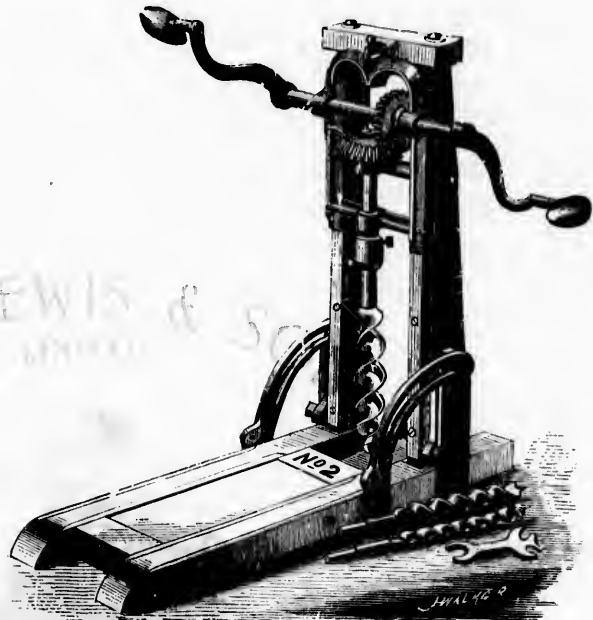

Style of Nos. 2 and 2 1/2

UPRIGHT

- No. 1—Round Shaft.....each \$5.00
- " 3—Square " " 6.30

ANGULAR

To slant one way, with Wrench.

- No. 2—Round Shaft.....each \$6.70
- " 2 1/2—Square " " 7.10

ANGULAR

To slant both ways, with Angle Indicator.

- No. 4—Round Shaft.....each \$6.70
- " 4 1/2—Square " " 7.10

Price Without Auger Bits.

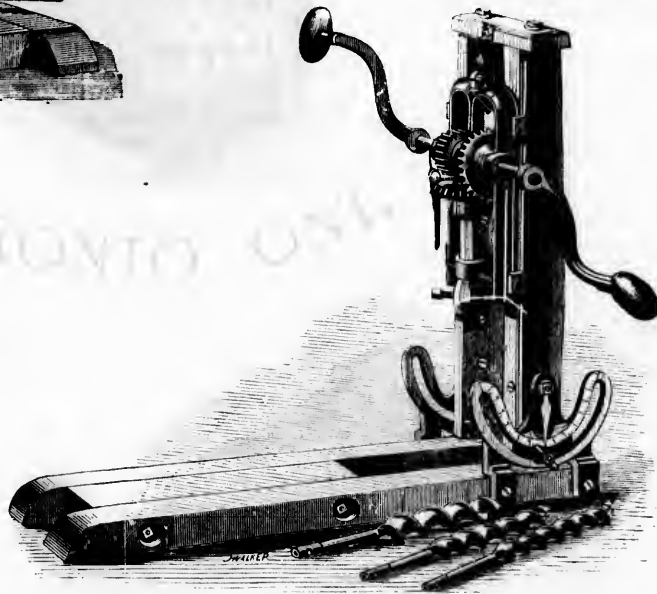

Style Nos. 4 and 4 1/2

For Auger Bits see page 105.

THE WILEY & RUSSELL MFG. CO'S

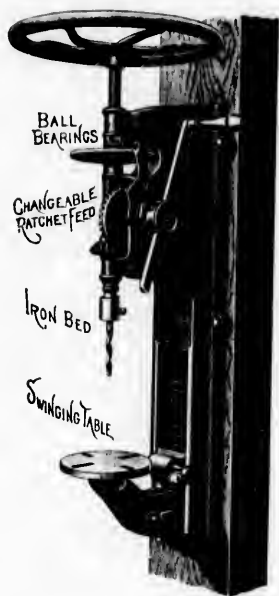

No. AA

NEW GREEN RIVER DRILLING MACHINES

We offer these machines with the novelty of a complete set of steel ball bearings, which gives relief to the friction and makes work very easy.

No. AA—Drills to 1 inch to 15 inch circle. Table can be raised or lowered 14 inches, weight 175 lbs. Price, each.....\$22.50

No. AA for Power—Fitted with tight and loose pulleys, enabling this machine to run by both hand and power, \$0.00 extra to list.

No. A1—Drills to 1 inch to 15 inch circle. Table can be raised or lowered 14 inches, weight 175 lbs. Price, each..... 22.50

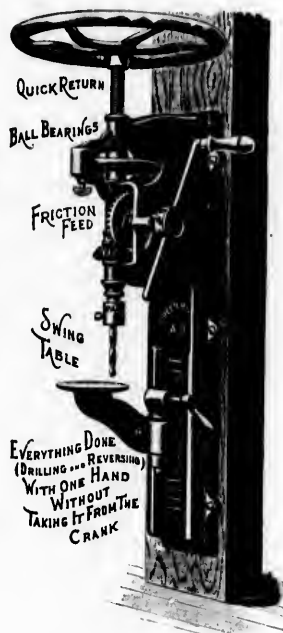

No. A1



No. 22

GREEN RIVER DRILLING MACHINES

No. 22—Drills to 1 inch to 15 inch circle. Table can be raised or lowered 14 inches, weight 180 lbs. Price, each \$27.00

No. 2—Drills to 1 inch to 15 inch circle. Table can be raised or lowered 14 inches, weight 180 lbs. Price, each 38.25

No. 2 For Power—Fitted with Pulley for Belt \$7.50 extra to list.

Spindles bored for $\frac{1}{2}$ inch Shank Drills.



No. 2

SILVER'S POST DRILLS



No. 730 x 1 1/2

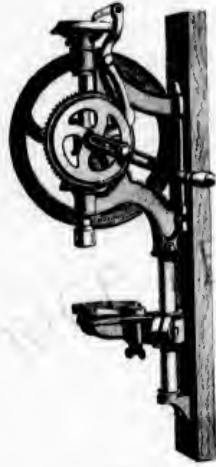

No. 731 x 1



No. 732 x 2



No. 734 x 3

① THREE DIFFERENT SPEEDS TO THE FEED

② CHANGEABLE FEED

③ QUICK RETURN

④ FAST AND SLOW SPEED

⑤ ROTATING SLOTTED TABLE

⑥ DRILLING, RETURNING AND REMOVING OF CHIPS ALL DONE WITH THE ONE MOTION AND WITHOUT STOPPING THE MACHINE

No. 730 x 1 1/2	—Drills 7/8 inch to 12 inch circle, weight	55 lbs...	each	\$ 7.00
" 731 x 1	" 3/4 " " 12 " " "	80 lbs...	"	9.50
" 732 x 2	" 1 " " 14 1/2 " " "	100 lbs...	"	11.25
" 734 x 3	" 1 1/4 " " 16 " " "	110 lbs...	"	13.00

WESTERN CHIEF DRILLS

No. 1—Drills 1 1/2 inch to 15 inch circle.
Price.....each \$20.25

No. 3—Drills 1 inch to 14 1/2 inch circle.
Price.....each 12.00

Spindles bored for 1/2 inch Shank Drills.



WESTERN CHIEF NO. 3

WESTERN CHIEF NO. 1

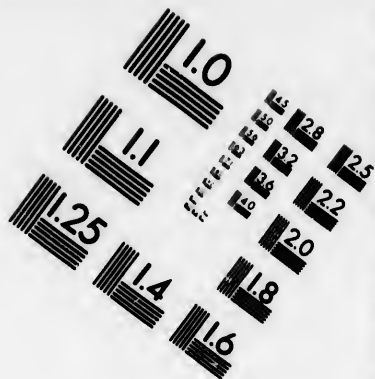
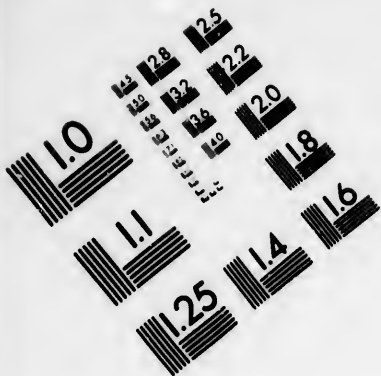

**IMAGE EVALUATION
TEST TARGET (MT-3)**

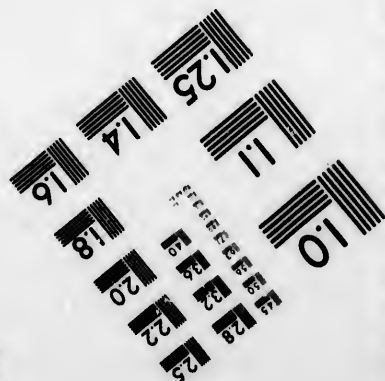
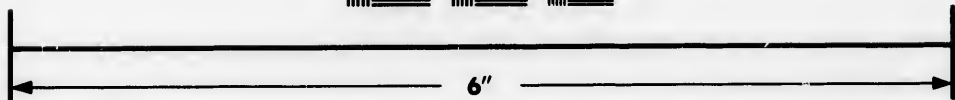
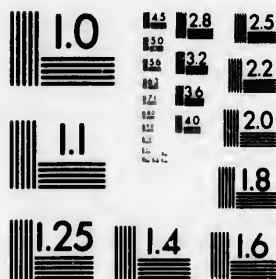

**Photographic
Sciences
Corporation**

23 WEST MAIN STREET
WEBSTER, N.Y. 14580
(716) 872-4503

18
20
22
25
28

10
11

COMBINATION PIPE VISES



PARKER'S PATENT

No.	Width of Jaws	Weight	Price
No. 87	3/4 inch	4 lb.	\$16.00

Holds Pipe 2 inches and under.



No.	Width of Jaws	Weight	Holds Pipe	Price
No. 100	3 1/2 inch	50 lb.	1/4 to 2 inch	\$16.00
" 105	4 "	65 "	1/4 to 3 "	20.00
" 113	4 "	83 "	1/4 to 2 "	14.00
" 115	4 1/2 "	85 "	1/4 to 3 "	18.00



No. 167

No. 167—Pipe Vise. It is adapted for all sizes from 1/8 rod to 2-inch pipe. It may be bolted to a bench, but when for portable use should be fastened to a 2x3 inch plank from 2 1/2 to 3 feet long. It will be found very useful to pump men for suspending the pipe from the platform while screwing the parts together, especially in deep wells. Price \$3.00

OPEN JAW PIPE VISES



**Cast Iron Frame. Wrought Iron Screw.
Cast Steel Jaws.**

No.	Weight	Holds Pipe	Price
No. 17	62 lb.	1/4 to 3 inch	\$11.00



Malleable Iron Frame.

No.	Weight	Holds Pipe	Price
No. 14	15 lb.	1/4 to 2 inch	\$ 6.00
" 24	60 "	2 to 6 "	27.00

PIPE VISES



No. 0



Nos. 15 and 20



Nos. 1 and 2



No. 5

No. 0	Steel (cast) Frame, Light Portable Pipe Vise, weight 10 lbs., holds Pipe $\frac{1}{4}$ to 2 inches.....	each	\$ 3.50
" 1	Malleable Frame, Hinged Pipe Vise	" 20 "	10.00
" 2	" " " " " " " "	" 20 "	14.00
" 5	" " " " " " " "	" 20 "	5.00
" 15	" " " " " " " "	" 25 "	6.50
" 20	" " " " " " " "	" 35 "	9.00

THE JARECKI PATENT PIPE VISE



Nos.....	1A	2A	3A	4A
Holds Pipe.....	$\frac{1}{4}$ to 2	$\frac{1}{2}$ to 4	1 $\frac{1}{2}$ to 6	6 to 12
Price.....	\$12.00	\$10.00	\$24.00	\$60.00

DRILL AND PLANER VISES

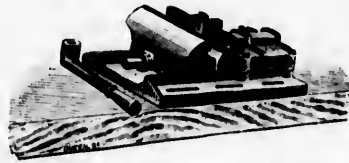

INSTANTANEOUS GRIP

No. 6E—Width of Jaws 5½ inches, Jaws open 6½ inches	\$42.70
" 8E " " 0 " " 8½ "	47.25

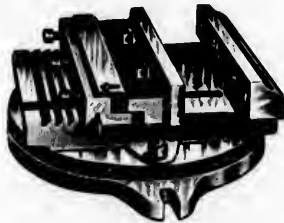

ROUND BASE

Width of Jaw.	Will Open.	Price.
6 inch	3½ inch	\$37.50
8 "	5 "	45.00
12 "	7 "	60.00



SQUARE BASE

Width of Jaw.	Will Open.	Price.
6 inch	3½ inch	\$30.00
8 "	5 "	37.50
12 "	7 "	52.50

WISE JAWS

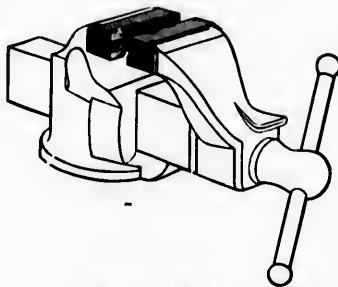

DETACHABLE V JAWS

Width of Jaw.	Per Set.
2 inch	\$2.50
4½ "	4.75
6 "	5.50

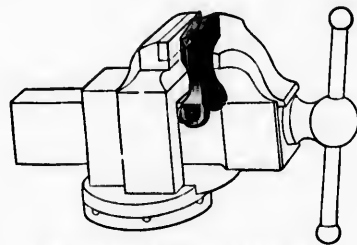

SELF-ADJUSTING TAPER JAW

Width of Jaw.	Price.
3½ inch	\$2.00
3½ "	2.75
4 "	3.25

The Taper Jaw may be instantly adjusted to or detached from the Vise. It is invaluable for holding irregular forms, and it is the most perfect Adjustable Jaw.

BENCH VISES

BLACKSMITHS,' SOLID BOX, WROUGHT IRON LEG

Approximate Weight of

Jaws.....	3	3½	3¾	4	4½	5	5½	6	6¾	7	inch.
About.....	20	25	30	35	50	80	100	100	120	150	lbs.

Peter Wright's..... Price, per lb. \$
 Brooks'..... " ; - 2½



WROUGHT IRON BOXES AND SCREWS FOR SOLID BOX VISES

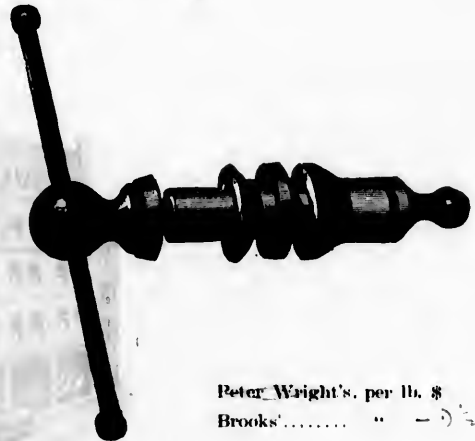

Peter Wright's, per lb. \$
 Brooks'..... " - 5½ 2½



No. 297

SHOWING VISE AND BRACKET.

BICYCLE TUBE VISE

No. 297 - Holds Bicycle Tubing ½, ¾, 1, 1¼ and 1½.

We can supply these Vises with either the regular screw movement (like cut) with spring opening jaws, or the instantaneous grip motion which is effected by means of a pin working on a cam, and tightens the jaws on the tubing in the quarter of a revolution.

Price, with Bracket \$8.25
 Price, without Bracket..... 7.50

..... \$32.70
 47.25

Price.
 \$30.00
 37.50
 52.50

Price.
 each \$2.00
 " 2.75
 " 3.25

sted to or de-
 or holding in-
 justable Jaw.

BENCH VISES

COACHMAKERS' VISES

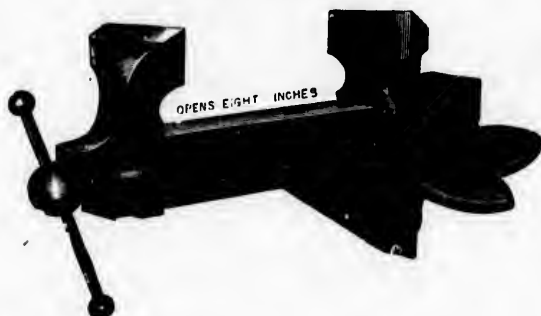

- No. 8—Jaws 4 inches, opens 8 inches each \$ 8.40
 " 10— " 3½ " " 7½ " with Swivel Jaw and Base " 10.75

PARKER'S

- No. 40—Jaws 4½ inches, opens 9 inches..... each \$15.40

OFFSET JAW VISES

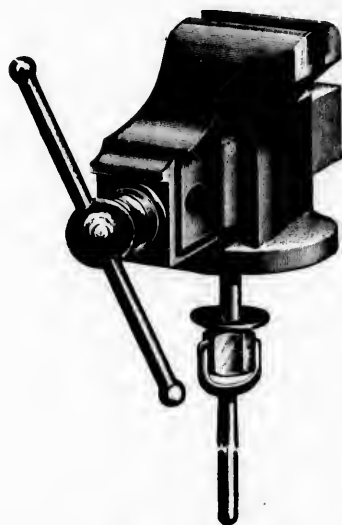

SWIVEL BASE

	Width Jaw.	Opens.	Weight.
No. 71	2 in.	3 in.	6 lbs.
" 72	4½ "	7 "	65 "
" 73	6 "	10 "	145 "

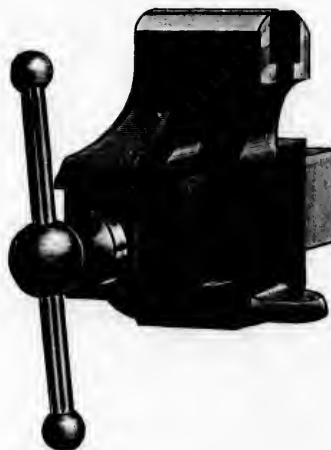

	Width Jaw.	Opens.	Weight.	Price.
No. 80—Straight Jaw	4½ in.	9 in.	60 lbs.	\$10.00
" 90—Offset	4½ "	9 "	60 "	10.50

BENCH VISES

PATENT INSTANTANEOUS-GRIP PARALLEL VISES

Save the First Cost in Twelve Months. Grips Instantly. Holds Firmly. No Lost Motion.

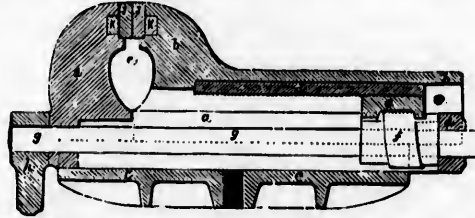

As will be readily understood from the sectional view, this Vise fastens any size of work instantly. Its action is simplicity itself. The work is held in one hand, and the Loose Jaw is with the other hand pushed against it, and by a little more than a quarter of a turn of the handle, the work is instantly and firmly fastened, all screwing being entirely dispensed with. When the work is too heavy for one hand, the fitter can hold it with both hands, and by a simple movement of the body throw the handle over and fasten the work without calling the aid of another man. The Vises will stand any amount of hard usage, and from the firmness of parts, it is almost impossible for them to get out of order. The grip is certain and does not relax under heavy work.

..... each \$ 8.40
 " 10.75



..... each \$15.40

BENCH VISE

(All Engaging Parts Steel.)

No. 0E—	Width of Jaws 3 inches,	Jaws open 3 inches			\$12.00
" 01E—	" " 4 "	" " 4 "			13.80
" 1E—	" " 5 "	" " 5 "			16.50
" 2E—	" " 6 "	" " 6½ "			19.80
" 3E—	" " 7 "	" " 8½ "			28.00

COACHMAKERS' VISE

Arranged for fixing on top of the bench, and made to swivel to any position to accommodate the work. Fitted with Steel Jaws.

No. 3J—Width of Jaws 4½ inches, Jaws open 3 inches \$14.35



JOINERS' VISE

For Cabinet Makers, Joiners, Pattern Makers, and Woodworkers generally.

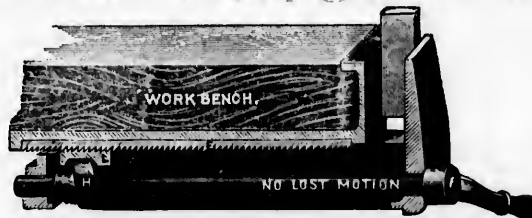

No. 1J

Works on same principle as Engineer's Vise. Fastens any size of work instantly. All screwing dispensed with. Economy of time saves first cost in six months.

No. 1J—	Width of Jaws 9 inches,	opens 12 inches			each \$61.00
" 0J—	" " 7½ "	" " 6 "	(Amateurs)		5.35

Jaws drilled to receive wood facings.

Weight. Price.
 10 lbs. \$10.00
 0 " 10.50

SIMPSON STATIONARY BENCH VISES



No.	Weight.	Jaws Open.	Width of Jaws.	Each.
No. 29	15½ lbs.	3½ inches	3 inches	\$6.35
" 30	20 "	4 "	3½ "	7.50
" 31	57 "	5 "	4 "	9.00
" 32	49 "	5½ "	4½ "	11.25
" 33	61 "	6½ "	5 "	11.10
" 95	130 "	9 "	6 "	24.00
" 96	100 "	10½ "	7 "	30.00

Nos. 95 and 96 have Solid Nut.

THE SIMPSON SWIVEL BENCH VISES



THE SIMPSON SWIVEL JAW BENCH VISES

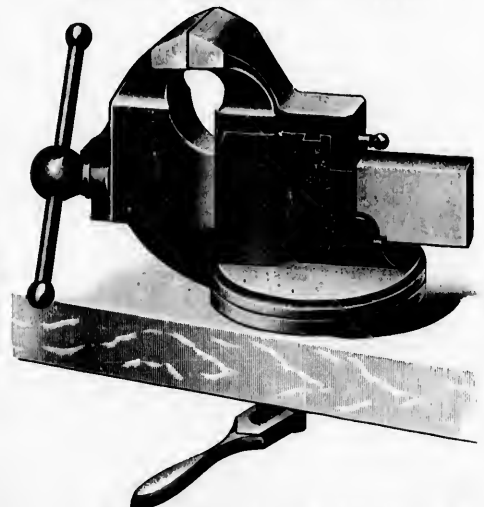

No.	Weight.	Jaws Open.	Width of Jaws.	Each.
No. 10	6½ lbs.	2 inches	2¼ inches.	\$3.40
" 12	17½ "	3½ "	3 "	6.20
" 13	28 "	4 "	3½ "	8.50
" 14	41 "	5 "	4 "	11.25
" 15	59 "	5½ "	4½ "	14.65

No.	Weight.	Jaws Open.	Width of Jaws.	Each.
No. 36	31 lbs.	4 inches	3¼ inches	\$ 9.60
" 37	40 "	5 "	4 "	11.85
" 38	63 "	5½ "	4½ "	14.65

The Simpson Patent Adjustable Parallel Vises can be instantly opened or closed the full length, without the use of the screw. By slightly raising the front jaw, the screw and nut are disengaged, on removing the hand, the screw and nut again become engaged and a single turn of the screw gives the required grip.

BENCH VISES

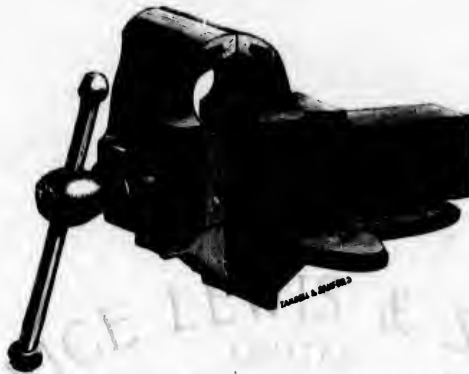

PARKER'S PATENT PARALLEL BENCH VISES
Wrought-Iron Strengthened.

Nos.	2	3	4	5
Weight	41½	50½	83	120 lbs.
Length of Jaws	4½	4¾	5½	6½ in.
Price..... each	\$13.50	17.63	24.40	30.00

PARKER'S PARALLEL VISES
Without Wrought-Iron Strengthened.

Nos.	100	200
Weight	31½	11½ lbs.
Length of Jaws	3½	11 in.
Price..... each	\$8.15	10.75

VISES



7 Jaws Each.
 es ... \$ 0.60
 " ... 11.85
 " ... 14.65
 without the use
 and, the screw

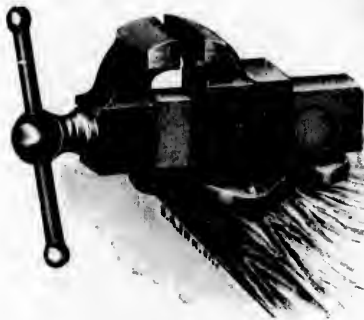

STATIONARY BASE

No.	Width Jaw.	Opens.	Weight.	List Price.
5H	3½ in.	4 in.	20 lbs.	\$6.85
15H	3½ "	5 "	30 "	7.75
25H	4 "	6 "	45 "	9.00
35H	4½ "	7 "	60 "	10.50



SWIVEL BASE

No.	Width Jaw.	Opens.	Weight.	List Price.
10H	3½ in.	4 in.	24 lbs.	\$8.50
20H	3½ "	5 "	35 "	9.35
30H	4 "	6 "	55 "	11.00

BENCH VISES

COMBINED ANVIL AND VISE



No. 1

Weights 52 lbs., Parallel Vise Opens 4 1/2 inches, Width of Jaws 3 1/2 inches, Anvil Face 3 1/2 x 8 inches, Height 6 1/2 inches.

No. 1—Complete, with 1 1/2 inch Hardy..... each \$5.75

DIAMOND ANVIL AND VISE

Steel Faced Jaws.

Anvil Face Polished.



Clamps Pipe up to 2 inches.



With Drilling Attachment; takes Square Shank Drills.



Will extend to hold work up to 12 inches.

Diamond Anvil and Vise, 4 inch Jaws, Anvil Face 7 x 3 inches.....each \$3.75

" " " " with Drill Attachment..... " 5.05

BENCH VISES



THE LITTLE GEM



Nos. 60 and 62

No. 50	The Little Gem, 1½ inch Jaws, opens 1½ inches	each	\$0.40
" 60	Amateur Vise, 1½ " " " 1½ " "	"	0.75
" 62	" " " 2 " " " 2½ " "	"	1.50



THE SIMPSON JEWELLERS' CLAMP VISES

No. 0	Weight 1½ pounds, 1½ inch Jaws, opens 1½ inches	each	\$1.40
" 1	" " 2½ " " 1½ " " " 1½ " "	"	2.00
" 2	" " 5½ " " 2½ " " " 2 " "	"	3.10

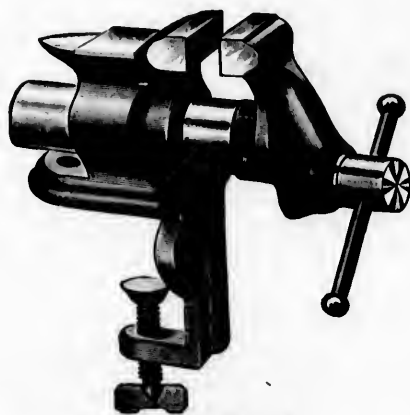

Nos. 2½ to 4½



No. 710

No. 1½	Without Anvil, 1 inch Jaws, opens 1½ inches	each	\$0.30
" 2½	Weight 1½ pounds, 1½ inch Jaws, opens 1½ inches	"	0.35
" 2½	" " 2½ " " 1½ " " " 2 " "	"	0.65
" 3½	" " 1½ " " 2 " " " 2½ " " Jaws and Anvil Face Chill Hardened	"	1.00
" 4½	" " 0½ " " 2½ " " " 2½ " " " " "	"	1.00
" 710	German Wrought Bench Vises, weights 3½ to 4½ pounds	"	1.50
" 4744	" " " " " 1 pound, similar to No. 710	"	0.40
" 4744	" " " " " ½ " " " 710	"	0.30

BENCH VISES



No. 1P

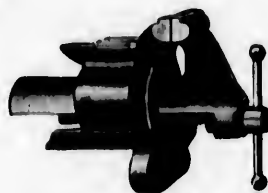

Nos. 2 to 5P

Japanned; Jaws, Anvil and Horn Ground and Polished.

No. 1P	Amateur Vise, 1 inch Jaws, opens 1 1/2 inches	each	\$0.20
No. 2P	Anvil Vises, weight 1 1/2 lbs., 1 1/2 inch Jaws, opens 1 1/2 inches	each	0.30
No. 2 1/2 P	" " " 2 1/2 " 1 1/2 " " " " 2 " "	"	0.65
No. 3P	" " " 4 " 2 " " " " 2 1/2 " "	"	0.80
No. 4P	" " " 6 " 2 1/2 " " " " 2 1/2 " "	"	1.35
No. 5P	" " " 8 " 2 1/2 " " " " 2 1/2 " "	"	1.75

Nos. 3P and 4P have Jaws and Anvil Chill Hardened, No. 5P Chilled and Hardened Anvil.



No. 10P with Slotted Base.



No. 20P with Swivel Base.

No. 10P	Weight 11 pounds, 3 inch Jaws, opens 3 1/2 inches	each	\$2.10
No. 20P	" " 10 " " 2 1/2 " " " " 3 1/2 " "	"	2.10

No. 10P has Chilled Jaws and Anvil. No. 20P Checked and Tempered Steel Jaws, Chill-Hardened Anvil.



Nos. 24, 29 and 34P



Nos. 25 and 30P

No. 24P	Weight 18 pounds, 3 inch Steel Jaws, Checked and Tempered	each	\$3.50
No. 29P	" " 25 " " 3 1/2 " " " " " " "	"	5.50
No. 34P	" " 35 " " 4 " " " " " " " "	"	7.00
No. 25P	" " 20 " " 3 " " " " " " " "	"	4.00
No. 30P	" " 30 " " 2 1/2 " " " " " " " "	"	6.00

SAW VISES



Nos. 1 and 100



No. 103



No. 104

No. 1	—Japanned, 8½ inch Jaws, Polished Face		per dozen	\$ 7.65
" 100	" 9½ " " " " "		"	7.15
" 103	" 9½ " " " " "	with Bench Clamp and Cam Adjustment, for holding Vise at any angle	per dozen	10.50
" 104	" 9½ " Planed Jaws, with Bench Clamp and Lever Adjustment, for holding Vise at any angle		per dozen	11.25



COMBINATION HAND VISE

With plate for use as a Bench Vise when desired.
Made from cast steel throughout.

Price per dozen \$5.25



HAND VISES



No. 1231

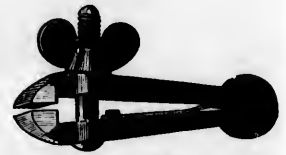

No. 1230

Size		3	3½	4	4½ inch.
No. 1231—Handled	per dozen	\$12.35	12.85	13.35
" 1230—Without Handle	"	10.25	10.75

BOSS HAND VISE

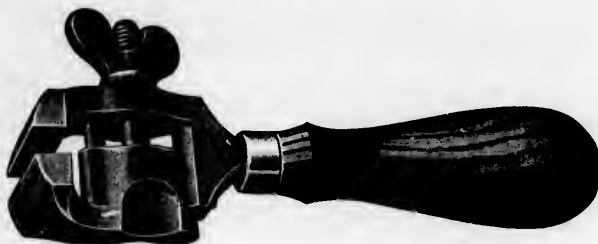

No. 2—Jaws $1\frac{1}{4}$ inch wide, opens $\frac{3}{4}$ inch. Hardened Steel Jaws, Polishedper dozen \$11.25

ALFORD HAND VISE



No. 1—Jaws $1\frac{1}{4}$ inch wide, opens $1\frac{1}{4}$ inch. Complete with Toolsper dozen 34.05

TELEGRAPH OR LINEMAN'S VISES

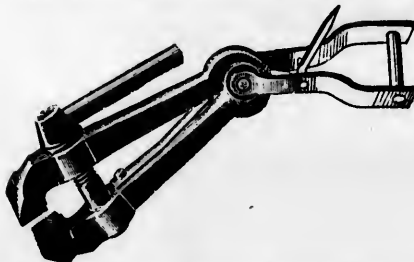

No. 19—Jaws $1\frac{1}{4}$ inch wide, opens $\frac{3}{4}$ inch, length 5 inches, with Buckle for $1\frac{1}{4}$ inch Strap..... per dozen 17.50

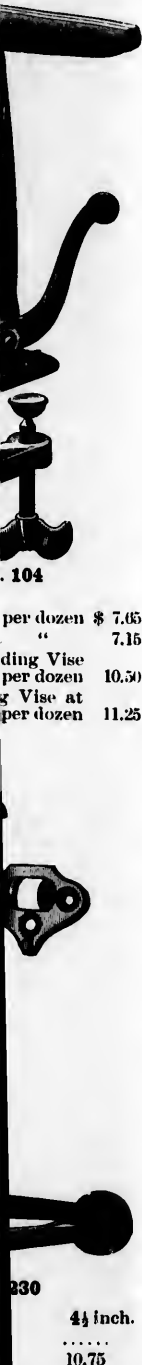

104

per dozen \$ 7.65
 " 7.16
 ding Vise
 per dozen 10.50
 g Vise at
 per dozen 11.25

330

$4\frac{1}{2}$ inch.

 10.75

CARPENTERS' CLAMPS

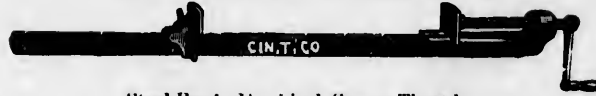

Steel Bar $\frac{1}{2} \times 1\frac{1}{2}$. $\frac{1}{4}$ inch Square Thread.

Nos.....	1	2	3	4
Opens.....	2 $\frac{1}{2}$	3	4	5 feet.
Per pair.....	\$5.65	6.00	6.75	7.50



No. 6—Length 3 ft., Maple Bar $1\frac{1}{2} \times 1\frac{1}{2}$. Mall, Thumb Screws, Ball and Socket Joint.....	per pair	\$1.50
" 7— " 4 ft. " $1\frac{1}{2} \times 1\frac{1}{2}$ "	" "	1.70

CARPENTERS' CRAMP SCREWS

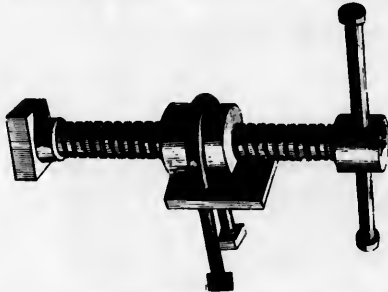

No. 11—1 inch diameter, Single Bolt....	per dozen	\$15.35
" 12—1 " " Double "....	" "	20.40

WOOD BENCH SCREWS

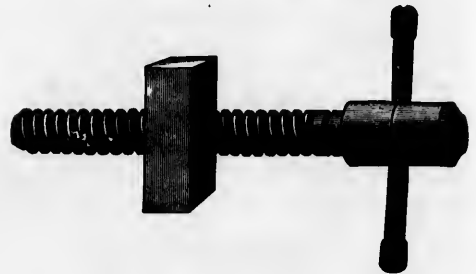

Each, $2\frac{1}{2}$ inch diameter.....	per dozen	\$4.00
---	-----------	--------

IRON BENCH SCREWS

Double Threads, 14 inches long. Cast Iron Heads and Nuts, Japanned, Wood Handles.

Wrought Iron, 1 inch diameter.....	per dozen	\$6.00
" " $1\frac{1}{4}$ " ".....	" "	6.75
" " $1\frac{1}{2}$ " ".....	" "	7.50



CABINET MAKERS' BENCHES

No. 1—20 inches wide, 4 ft. 6 inches long, 32 inches high, Hardwood Frame, Maple Top—with Front and Tail Vise and Holes for Stops....	each	\$13.00
---	------	---------

HAND SCREWS

WROUGHT IRON SCREWS WITH METAL BEARINGS

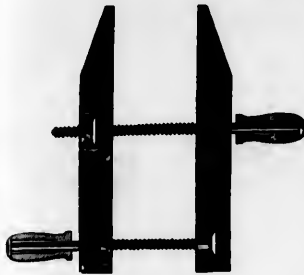

Length of Jaw	6	8	10	12	14	16	inch.
Jaws Open	5½	6½	7½	8½	9½	10½	"
Diameter of Screw	¾	¾	¾	1	1	1¼	"
Size of Jaw	1½ × 1½	1½ × 1½	1¾ × 1¾	1¾ × 1¾	1¾ × 2	1¾ × 2½	"
Price, per dozen	\$0.20	0.20	0.20	7.35	8.50	10.25	

HARD MAPLE, SECOND GROWTH HICKORY SPINDLES



Nos.	1	1½	2	3	4	5	6	8	
Length of Jaw	7	8½	10	12	12	14	14	10	inch.
Jaws Open	4	5	6½	6½	8½	8	10	10½	"
Diam. of Screw	½	¾	¾	¾	¾	¾	¾	1	"
Size of Jaw	1½ × 1½	1¾ × 1½	1¾ × 1¾	1¾ × 1¾	1¾ × 1¾	2 × 2	2 × 2	2½ × 2½	"
Price, per doz.	\$2.80	3.45	4.40	5.00	5.65	6.25	6.90	8.15	

MALLEABLE IRON SCREW CLAMPS

WITH WROUGHT IRON SCREW, SWIVEL HEAD

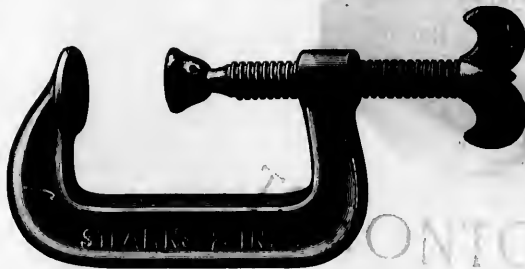

Size	3	4	5	6	inch.
Per dozen	\$2.00	4.20	5.00	6.50	
Size	7	8	9	10	inch.
Per dozen	\$7.80	9.00	10.00	11.00	

COE'S PATENT ADJUSTABLE SCREW CLAMPS



Size	4	6	8	inch.
Per dozen	\$11.00	16.50	22.00	

STEARNS' ADJUSTABLE CLAMPS



ADJUSTABLE SCREW CLAMP

Size	3	5	7	9	12	16	inch.
Per doz.	\$5.00	0.10	12.00	14.70	21.00	28.00	

ADJUSTABLE CORNER CLAMP

Size	6	9	inch.
Per doz.	\$11.20	16.80	

Packed half-dozen in a box.

GAME TRAP CLAMPS

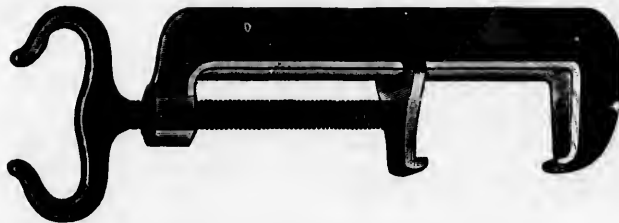

No. 5—Opens to 4 inches	per dozen \$ 9.00
“ 6— “ 5½ “	“ 15.00

These Clamps are specially adapted for setting large bear traps.

QUILT FRAME CLAMPS

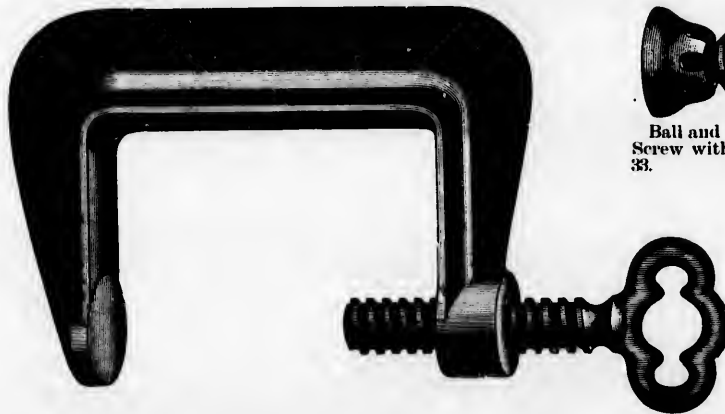

Ball and Socket Head Screw with Nos. 32 and 33.

No. 1

No. 1—Japanned, opens 2½ inches, Plain Head Screw	per dozen \$0.65
“ 32— “ “ 2½ “ “ Ball and Socket Head Screw	“ 0.95
“ 33— “ “ 3 “ “ “ “ “	“ 1.25

Packed one dozen in a box.

QUILT FRAME CLAMPS



LAMP

9 inch.
10.80

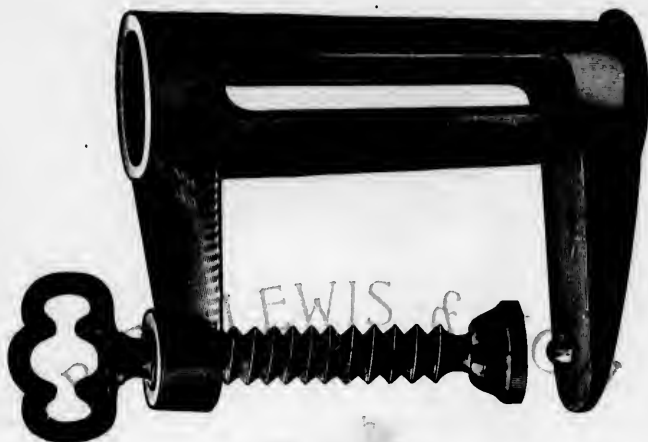

No. 4—FULL SIZE

No. 3—Novelty, Japanned, same size as No. 4, but without Swivel End per doz. \$1.15
 " 4— " " with Swivel End " 1.45

Packed one dozen in a box.

per dozen \$ 9.00
 " 15.00

CHEESE PRESS SCREWS

CIDER PRESS SCREWS



Socket Head
Nos. 32 and



Heavy Square Thread, three to the inch. Nut, Flange and Base Japanned. 22 inches over all, 1 1/4 diameter.

Each..... \$3.75



Wrought Screw, Cast Nut, 20 x 1 1/4 inches.

Each..... \$2.25

per dozen \$0.65
 " 0.95
 " 1.25

LeCOUNT'S PATENT TOOLS

IMPROVED STEEL DOG

With Hardened Steel Screws turned in the Lathe.



PRICES

No. 1— $\frac{3}{4}$ in.	\$0.35
" 2— $\frac{1}{2}$ "	0.35
" 3— $\frac{1}{4}$ "	0.50
" 4—1 "	0.60
" 5— $1\frac{1}{4}$ "	0.75
" 6— $1\frac{1}{2}$ "	0.85
" 7— $1\frac{3}{4}$ "	1.00
" 8—2 "	1.10

Small Set of 8 Dogs, from $\frac{3}{4}$ to 2 inches 5.50

No. 9— $2\frac{1}{4}$ in.	1.40
" 10—3 "	1.50
" 11— $3\frac{1}{2}$ "	1.70
" 12—4 "	1.00

Set of 12, from $\frac{3}{4}$ to 4 inches 12.00

23x5 $\frac{1}{2}$ inch
13 "
15 $\frac{1}{2}$ "
425 lbs.

per lb.
Resin 15

NEW STEEL DOG

With Steel Screws, Lathe Made and Hardened.



This Dog is very heavy, and is warranted not to break with any work.

PRICES

No. 1— $\frac{3}{4}$ in.	\$0.40
" 2— $\frac{1}{2}$ "	0.40
" 4—1 "	0.60
" 6—1 "	0.70
" 8— $1\frac{1}{4}$ "	0.80
" 10— $1\frac{1}{2}$ "	0.95
" 11— $1\frac{3}{4}$ "	1.10
" 12—2 "	1.20

Small Set of 8 Dogs, from $\frac{3}{4}$ to 2 inches 6.15

No. 14— $2\frac{1}{4}$ in.	1.45
" 15—3 "	1.60
" 16— $3\frac{1}{2}$ "	1.80
" 17—4 "	2.10

Set of 12, from $\frac{3}{4}$ to 4 inches 11.10

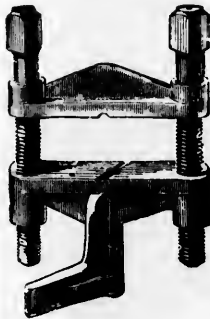

PATENT CLAMP DOG

Used for finished work and for many other purposes.

They are well made, and of four sizes, taking anything from close to sizes given.

Made of Malleable Iron.

No. 1—Opens 1 inch....	\$1.40
" 2— " 1 $\frac{1}{2}$ "	1.45
" 3— " 2 "	1.80
" 4— " 3 "	2.20

Set of four, \$6.85

STEEL DOG WRENCH



Fitting Screw Heads from $\frac{3}{4}$ to $\frac{7}{8}$ in. square.

Will answer for both Dogs and Tool Post.

It is finished and hardened.

Price \$1.05

ADJUSTABLE PLANER BLOCKS.



No. 1—3 to 4 inches.....	each	\$2.00
" 2—4 to 5 $\frac{1}{2}$ "	"	2.20
" 3—5 $\frac{1}{2}$ to 7 $\frac{1}{2}$ "	"	2.80
" 4—7 $\frac{1}{2}$ to 11 "	"	3.50



No. 1S— $1\frac{1}{4}$ to $1\frac{1}{2}$ inches.....	each	\$0.45
" 2S— $1\frac{1}{4}$ to 2 "	"	0.50
" 3S—2 to 2 $\frac{1}{2}$ "	"	0.60
" 4S—2 $\frac{1}{2}$ to 3 $\frac{1}{4}$ "	"	0.75
" 5S—3 $\frac{1}{4}$ to 5 $\frac{1}{4}$ "	"	0.95

Anvil;

5
50lbs
7.50

each \$1.20
" 3.50

CUSHMAN'S INDEPENDENT CHUCK

FOUR JAWS, REVERSIBLE

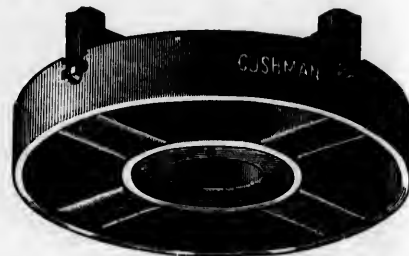
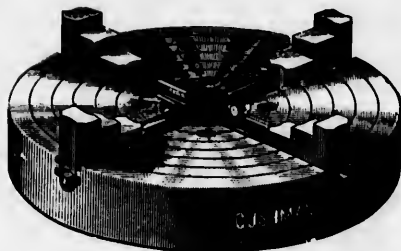

The jaws of these Chucks can, in a moment's time, be run out and reversed, a feature seldom found in other chucks of this kind. The screw is made with a long bearing at each end, and should the square end become broken or worn, it can be reversed and the other end fitted to the key. The jaws and screws are made of steel and the bearings are accurately fitted. A key-wrench made of bar steel and four bolts for attaching to face-plate are furnished with each Chuck.

Diameter..... inches	8	9	10	12	14	16	18	20	24	26
Diameter of Hole..... "	1 $\frac{1}{4}$	1 $\frac{1}{2}$	2	2 $\frac{1}{4}$	3	3	4	4	4 $\frac{1}{2}$	4 $\frac{3}{4}$
Diameter of Face-Plate..... "	4 $\frac{1}{2}$	4 $\frac{3}{4}$	4 $\frac{3}{4}$	6 $\frac{1}{4}$	6 $\frac{1}{2}$	6 $\frac{1}{2}$	7 $\frac{1}{2}$	7 $\frac{1}{2}$	9 $\frac{1}{2}$	9 $\frac{1}{2}$
Price.....	\$22.00	21.00	26.00	30.00	34.00	38.00	44.00	50.00	65.00	75.00

WESTCOTT'S PATENT GEARED COMBINATION LATHE CHUCK

INDEPENDENT, UNIVERSAL, ECCENTRIC. JAWS REVERSIBLE

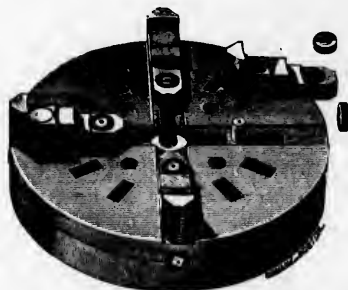

Front view of Chuck, showing manner of reversing the Jaws.



Inside view of Four-Jaw Chuck, showing the Screw and Pinions, the nut under the Jaw and the Gear which is loose in the Back Shell.

The following points of superiority are claimed :

Strongest Grip, Greatest Capacity, Greatest Durability, Easiest Adjustment, Cheapness

Diameter.....	5	7 $\frac{1}{2}$	10 $\frac{1}{8}$	13	15 $\frac{1}{4}$	18	21	24 inch.
Will hold inside of Jaws.....	5	7 $\frac{1}{2}$	10 $\frac{1}{8}$	13 $\frac{1}{8}$	17	19 $\frac{1}{2}$	25 $\frac{1}{2}$	28 "
Three Jaws.....	\$21.00	26.00	34.00	44.00	52.00	62.00	80.00	100.00
Four Jaws.....		32.00	42.00	56.00	64.00	75.00	95.00	120.00

CUSHMAN'S IMPROVED GEARED SCROLL CHUCK

UNIVERSAL—THREE PINIONS

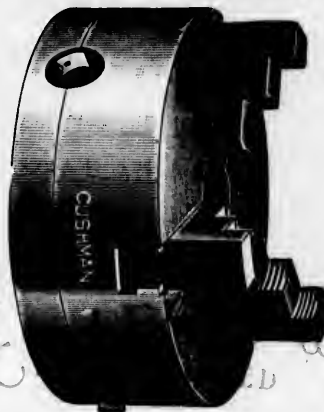
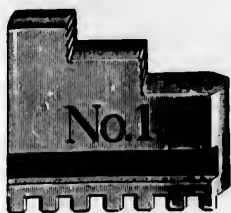

No. 1 Jaws are the style most generally used and are designed for ordinary lathe work. They can be furnished with all except the Drill Chucks. With this style of Jaws, pieces as large as the Chuck itself may be held.

No. 2 Jaws are designed for drilling, holding rods and for fine work. With this style of Jaws, rings, etc., can be held by the inside, while the outside is being finished. This style of Jaw is also furnished with all Chucks when so ordered, except the Drill Chucks.

The working parts are made of Forged Steel, the Jaws are ground true after they are hardened. When ordering be particular to state style of Jaws wanted. Chucks with No. 1 Jaws usually kept in stock.

Diameter.....	2½	3	4	5	6	9	12	15
Price, with 1 set of Jaws.....	\$ 0.40	12.50	15.00	18.75	22.50	30.00	37.50	50.00
“ “ 2 “	\$11.25	15.00	18.00	22.50	27.00	30.00	45.00	60.00
Separate Jaws per set.....	\$ 2.85	3.75	4.70	5.65	6.90	11.25	15.00	18.75

AMATEURS' LEVER CHUCKS

These Chucks are designed for light work. They are, on account of being strongly made of first-class material, suitable for any work within their capacity. For small lathes, there is nothing better made, and the price is very low for superior work.

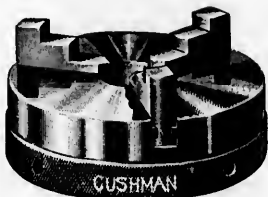

Diameter.....	2	3	4	5
Price, with 1 set of Jaws.....	\$5.65	6.00	8.15	9.40
“ “ 2 “	7.20	8.45	10.00	11.25
Separate Jaws per set.....	2.35	2.35	2.85	2.85

Chucks with 2 sets of Jaws usually kept in stock.

IMPROVED TWO-JAW CHUCKS

With Slip Jaws.



Round Body.



Box Body.

They are furnished in two styles, as shown above and in table below. Those with round body are made to bolt to a face-plate, while those with box body are to be threaded to fit the spindle.

The 4½ inch, 6 inch, and 7 inch round body with connected jaws have the screw at the side, giving an unobstructed hole through the Chuck.

Size.....	4½	6	7	9	12	15
Jaws take	2	2½	3	4	6	8
Round Body..... each	\$22.40	28.00	33.60	42.00	50.40
Box Body	33.60	42.00	50.40	58.80

DRILL CHUCKS

STETSON'S PATENT IMPROVED

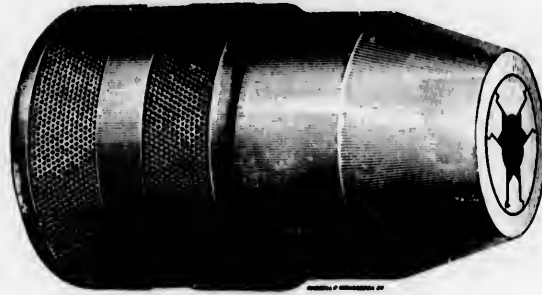

Full Size No. 2

No. 2—Holding 0 to $\frac{1}{2}$ inch..... each \$10.15

BEACH PATENT DRILL CHUCK



Nos.....	0	1	2	3	4
Hold Drills.....	0 to $\frac{1}{4}$	0 to $\frac{1}{2}$	0 to $\frac{3}{4}$	$\frac{1}{2}$ to $\frac{1}{2}$	$\frac{1}{8}$ to $\frac{1}{2}$
Each.....	\$14.00	14.00	15.50	18.25	20.00

ALMOND DRILL CHUCK

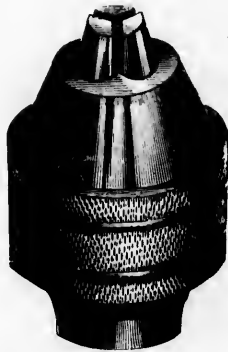

Nos.....
Hold Drills.....
Each.....



1	2	3
0 to $\frac{1}{8}$	0 to $\frac{1}{8}$	0 to $\frac{1}{2}$
\$8.00	6.00	11.25

TRUMP CHUCK



SELF-CENTERING, THREE JAWS

No. 1—For Drills $\frac{1}{2}$ and under, Shank 2x $\frac{1}{4}$..each \$2.00
 " 2— " " " 2 $\frac{1}{2}$ x $\frac{1}{4}$.. " 4.30
 Extra Jaws..... per pair 0.00

DRILL CHUCKS

WESTCOTT'S "LITTLE GIANT" IMPROVED

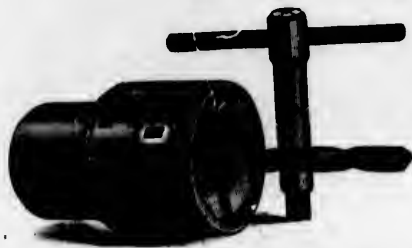

Screw for "Little Giant" Drill Chuck.

This Chuck has no projections. The Jaws and Screws are all within the body.
The Jaws are of the best tool steel, carefully hardened.
All parts duplicated.

Nos.	00	0	1	2
Holds Drills	0 to $\frac{1}{4}$	0 to $\frac{1}{2}$	0 to $\frac{3}{4}$	0 to 1
Each	\$0.05	11.00	12.40	13.75
Screws	each \$1.00	1.00	1.00	2.10
Jaws	per pair \$3.80	4.30	4.75	5.25

"ONEIDA" DRILL CHUCKS

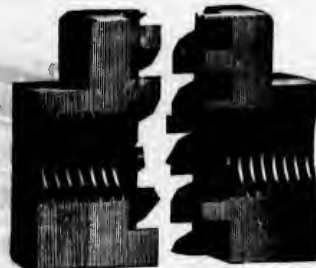

Cut showing the Diagonal Tongued Jaws.

No. 0 Holds Drills 0 to $\frac{1}{4}$	each	\$ 0.05
" 1 " " 0 to $\frac{1}{2}$	"	11.00
Screws	"	2.00
Jaws	per pair	4.50

CUSHMAN'S DRILL CHUCKS

KEY DRILL CHUCK



THE HARTFORD DRILL CHUCK



No. 2—Diameter $2\frac{3}{4}$ inches.

No. 1 holds from 0 to $\frac{1}{2}$ inch	price	\$8.15
" 2 " " $\frac{1}{4}$ to $\frac{3}{4}$ "	"	10.00
No. 0 holds from 0 to $\frac{1}{4}$ inch	price	\$7.50
" 1 " " 0 to $\frac{1}{2}$ "	"	8.75
" 2 " " 0 to $\frac{3}{4}$ "	"	10.00

DRILL CHUCKS

PEERLESS DRILL CHUCK



Holds Drills 0 to $\frac{1}{4}$ inch, Self-tightening, three Jaws.
 Price each \$5.00

THE ACME DRILL CHUCK



Holds from 0 to $\frac{1}{4}$ inch, Self-tightening, three Jaws.
 Price each \$5.00

BARBER'S LATHE CHUCK



No. 2—With Shank, $\frac{1}{4}$ inch diameter \times 4 inches, Forged Steel Jaws each \$2.50

STAR CHUCK



No. 1—With Shank, $\frac{1}{4}$ inch diameter \times $1\frac{1}{4}$ inches, holds Drills 0 to $\frac{1}{8}$ inch each \$1.65
 " 2— " " " \times $\frac{3}{4}$ " " " 0 to $\frac{1}{4}$ " " " 2.50
 " 3— " " " \times $\frac{1}{2}$ " " " 0 to $\frac{1}{4}$ " " " 5.00

PATENT PLUG ARBOR FOR DRILL CHUCKS



These Arbors are left with one end blank for fitting to machine and with the other end already fitted to our Chucks. By turning the nut, the Chuck may be easily forced off the Arbor or the Arbor drawn from the Spindle.
 No. 2 fits the 2-inch Amateur Geared, the 2-inch Amateur Lever, the 2-inch Hartford Lever, the No. 1 and No. 0 Hartford Drill, the No. 1 and 2 Key Drill, the Peerless and the Acme Chucks.
 The No. 3 fits the No. 2 Hartford only.

No. 2 \$1.25
 " 3 1.00

BELL CENTERING PUNCH



Capacity is up to $1\frac{1}{4}$ inch each \$1.25

8-INCH SCREW-CUTTING FOOT-POWER LATHE

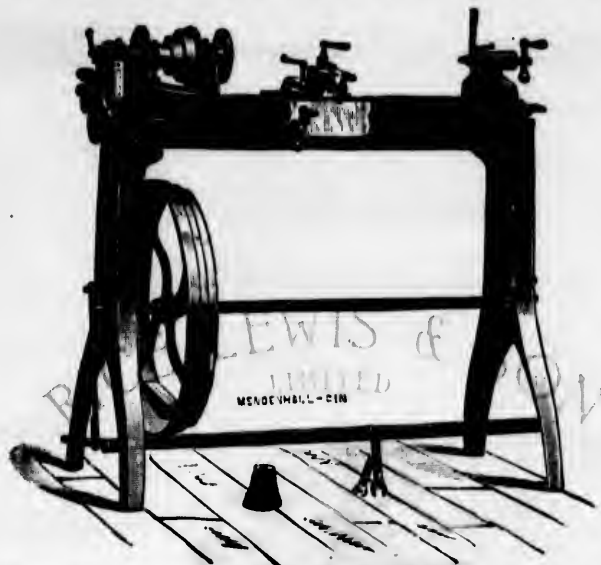

This Lathe swings 9 inches over bed, and is built to take 20, 30 or 30 inches between centers.

This Lathe has balanced cone pulley for 1-inch belt. Head-stock spindle has front bearing $1\frac{1}{8}$ inches in diameter and $1\frac{1}{2}$ inches long, running in gun metal boxes, provision being made to take up the wear. These Lathes are built with a $\frac{3}{4}$ -inch hollow spindle, and are furnished with either foot motion or countershaft, as may be desired.

We furnish with this Lathe a face-plate, wrenches, two pointed centers, and gear to cut all standard threads from 3 to 40, and these may be arranged to cut an unlimited number of threads either right or left-hand.

This Lathe is built with bench-legs; also reverse head and compound rest when desired.

PRICE

Swing.	Bet. Centers.	Length of Bed.	Weight.	Each.
8 inches.....	20 inches.....	30 inches.....	325 lbs.....	\$110.50
8 ".....	30 ".....	40 ".....	345 ".....	127.50
8 ".....	30 ".....	52 ".....	365 ".....	144.50

Reverse Head, \$17.00 extra. Compound Rest, \$17.00 extra.

RULE FOR STUD OR INTERMEDIATE GEAR.

For arranging the stud gear 2 to 1 and 1 to 2: 2 to 1 is arranged as follows: 80 of 80-30 meshes with 30 of 60-30 and also with spindle gear, and 60 of 60-30 meshes with screw gear. For 1 to 2, or slow feed, 80 of 80-30 meshes with spindle gear, and also with 60 of 60-30, and 30 of 60-30 meshes with screw gear.

10-INCH SCREW-CUTTING FOOT-POWER LATHE

The 10-inch Lathe, similar to the above, will swing $10\frac{1}{2}$ inches over the bed. It has balanced three-speed cone pulley for $1\frac{1}{4}$ -inch belt. Head-stock spindle has front bearing $1\frac{1}{8}$ inches in diameter and $2\frac{1}{2}$ inches long, and there is a $\frac{3}{4}$ -inch hole through spindle. The spindle is run in gun metal boxes, provision being made to take up the wear. These Lathes are built with either foot motion or countershaft. We furnish with this Lathe, face-plate, steady-rest, wrenches, 2 pointed centers, and gear to cut all standard threads, right or left hand, from 5 to 30.

PRICE

Swing.	Bet. Centers.	Length of Bed.	Weight.	Each.
10 inches.....	24 inches.....	4 feet.....	475 lbs.....	\$181.50
10 ".....	30 ".....	5 ".....	525 ".....	198.00
10 ".....	48 ".....	6 ".....	575 ".....	214.50

Compound Rest, \$21.45 extra.

RULE FOR STUD OR INTERMEDIATE GEAR.

For arranging the stud gear 2 to 1 and 1 to 2: 2 to 1 is arranged as follows: 60 of 60-24 meshes with 30 of 60-30, and also with spindle gear, and 60 of 60-30 meshes with screw gear. For 1 to 2, or slow feed, 60 of 60-24 meshes with spindle gear, and also with 60 of 60-30, and 30 of 60-30 meshes with screw gear.

HORSE TOOTH RASPS



- No. 1 —Plain Horse Tooth Rasp, 20 inch, Handled per doz. \$13.50
 " 1P—Plated " " " " " 17.85

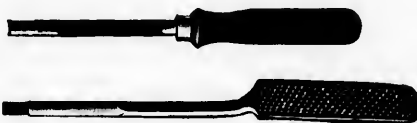

- No. 2 —Plain Horse Tooth Rasps, Jointed, Handled per doz. \$24.30
 " 2P—Plated " " " " " 28.65



Cut showing Adjustable Section.

- No. 3—Adjustable, Plated, Horse Tooth Rasp with one section each..... per doz. \$20.25
 Sections, Half File and Half Rasp for above..... " 4.05

VETERINARY RIFFLERS

Length 14 inches over all.

- No. 5—Plain, one end Flat File, other end Rasp, Concave per doz. \$12.15

EMERY WHEEL DRESSERS



- No. 3 —Steel Bushing and Arbor per doz. \$15.00
 Extra Wheels and Washers per doz. sets 8.40

FILE CLEANERS



No. 1

- No. 1—Mounted, Card 4 x 2 inch per doz. \$2.00
 " 2— " 4 x 1½ " " 3.10

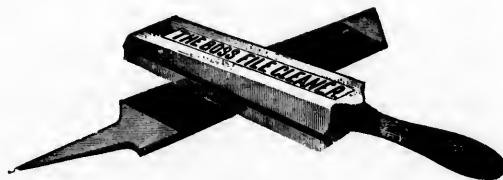

No. 2

FILES

Sections, showing dimensions of Files in most general use.

per doz. \$13.50
" 17.85

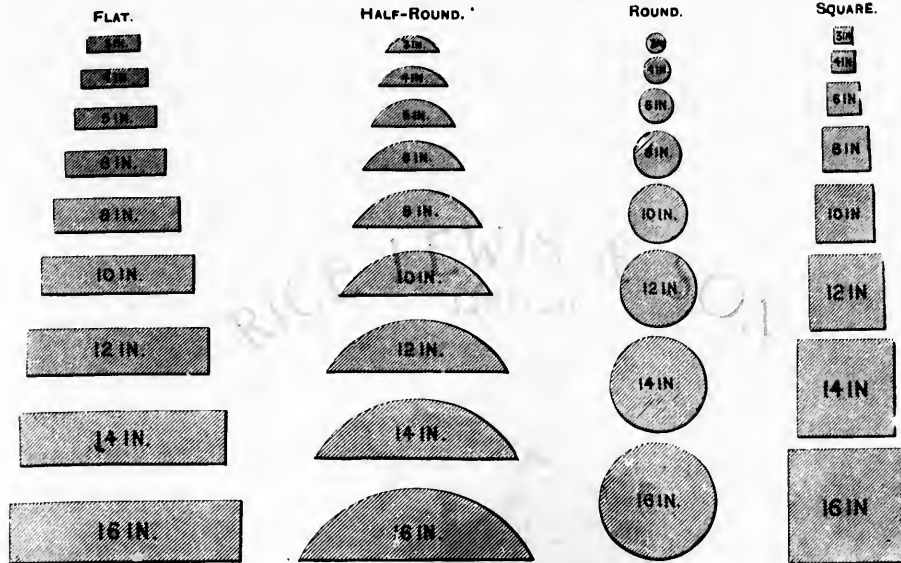

per doz. \$24.30
" 28.65

per doz. \$20.25
" 4.05

per doz. \$12.15

Sections, showing cuts of Files and Rasps.

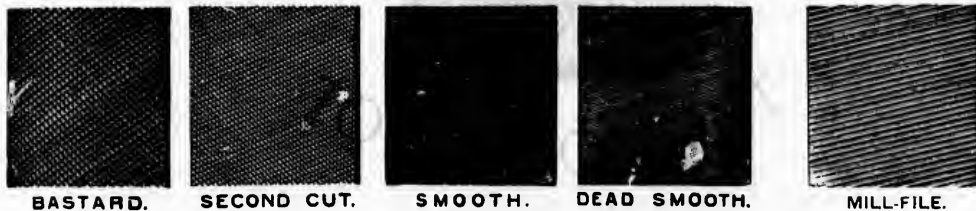

per doz. \$15.00
oz. sets 8.40

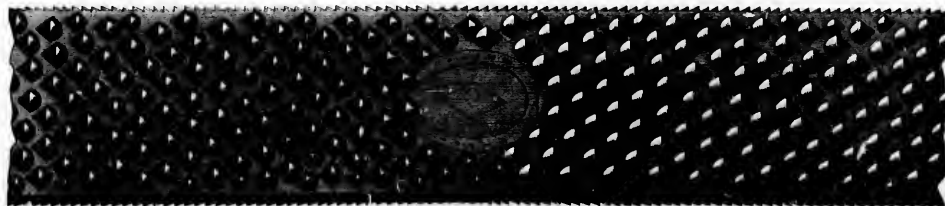

per doz. \$2.00
" 3.10

HORSE RASP

FILES

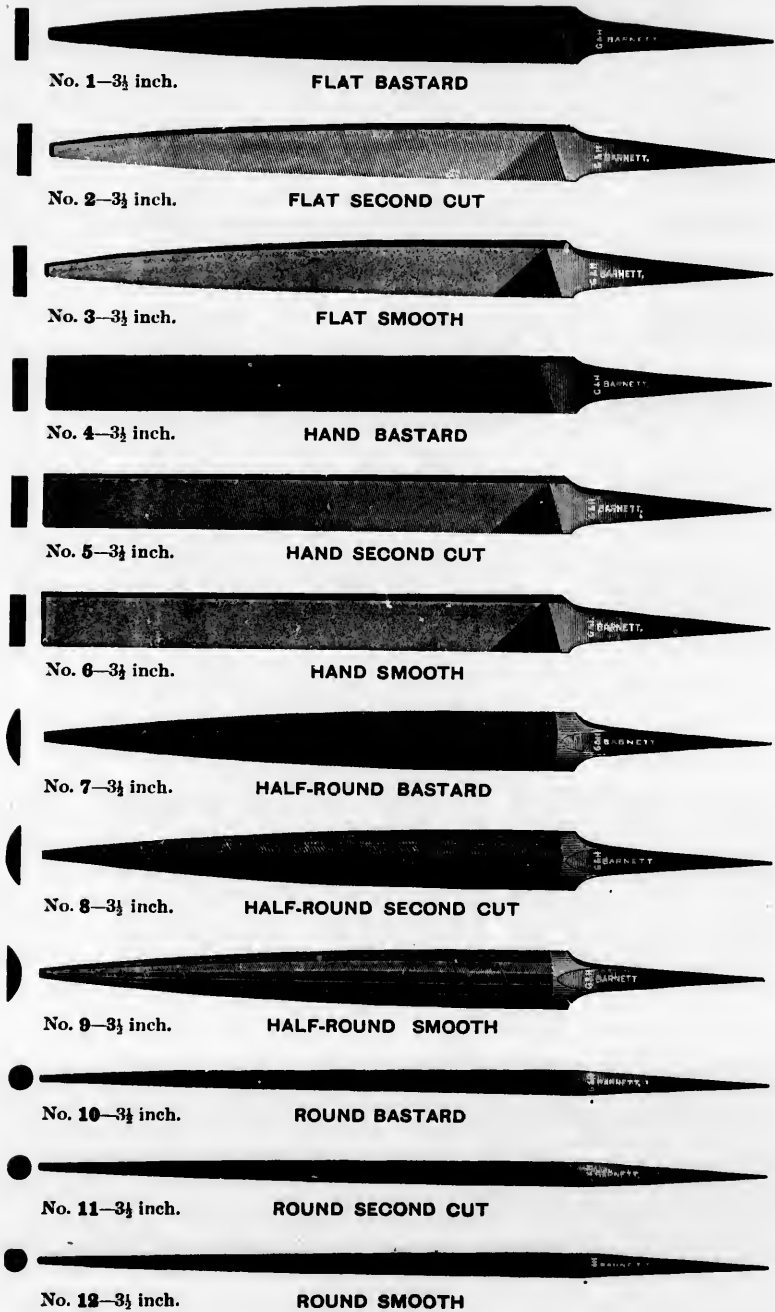

FILES

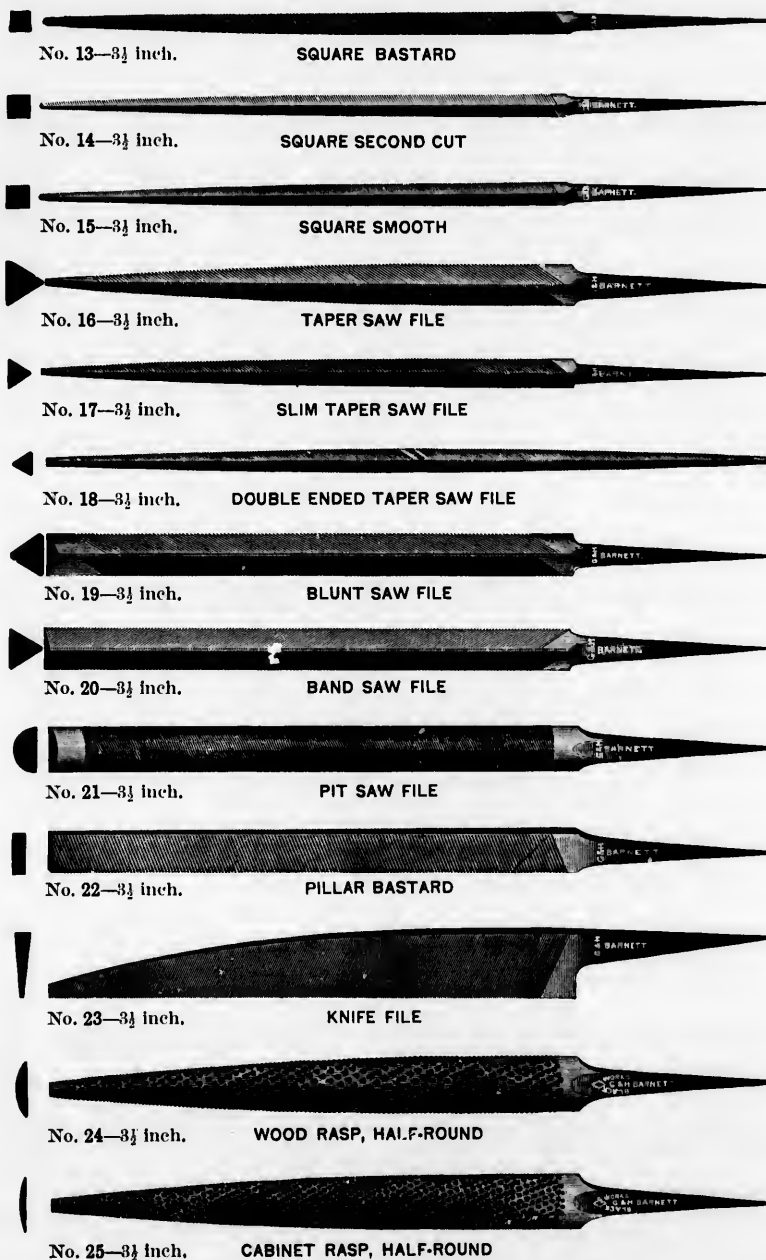



BLACK DIAMOND FILES

PRICE LIST OF FILES AND RASPS

ADOPTED BY THE FILE MANUFACTURERS OF THE UNITED STATES AND CANADA, TO TAKE EFFECT ON AND AFTER JULY 1st, 1897.

INCH.		MILL. AND ROUND.		FLAT.		INCH.		SQUARE.		HAND AND PILLAR.		INCH.		HLF. RO. & THREE SQ.		WARDING.	
		2d Cut		2d Cut				2d Cut		2d Cut			2d Cut			2d Cut	
4		2.60		3.20		4		3.40		3.20		4		4.20		3.60	
5		2.80		3.40		5		3.60		3.50		5		4.50		3.90	
6		3.00		3.60		6		3.80		3.80		6		5.00		4.40	
7		3.40		4.10		7		4.30		4.30		7		5.70		5.10	
8		3.70		4.50		8		4.70		4.70		8		6.20		5.60	
9		4.20		5.40		9		5.70		5.80		9		7.00		6.70	
10		4.80		6.00		10		6.30		6.50		10		7.50		7.50	
11		5.80		7.30		11		7.70		8.10		11		8.80		9.40	
12		6.40		8.20		12		8.60		9.20		12		9.70		10.60	
13		8.00		10.10		13		10.60		11.30		13		11.50		12.90	
14		9.10		11.40		14		12.00		12.70		14		12.70		14.50	
15		11.10		13.60		15		14.30		15.30		15		15.20			
16		12.50		15.00		16		15.80		17.00		16		16.80			
17		15.10		18.00		17		18.90		20.20		17		20.10			
18		16.90		20.00		18		21.00		22.30		18		22.30			
19		20.50		23.60		19		24.80		26.40		19		26.60			
20		22.90		26.30		20		27.30		29.20		20		29.40			
Mill Blunt, Dbl. Cut, adv. 2 in.			Cant (Blunt) Dbl. Cut			Square Blunt, advance 1 in.			Slotting (Bl.) adv. 2 in.			Ginsaw, take standard price.			Warding.		
Mill Dbl. Cut, " 1 "			advance 2 in.						Cutter Blunt or Taper			Creeper, adv. 2 in.			8 inch, . \$7.00		
Mill Narrow Point, " 1 "									advance 2 1/2 in.			Turnbler, " 2 "			Starosaw Improved.		
												Feather Edge (Blunt) " 2 "			6 inch, . \$4.80		
												High Back " 2 "			7 " " . 5.50		
												Half Round " 2 "			9 " " . 7.20		
															10 " " . 8.00		
															12 " " . 11.50		

INCH.		MILL. ONE ROUND EDGE.		MILL. TWO ROUND EDGES.		INCH.		TAPER.		SLIM TAPER.		BANDSAW. BLUNT & TAPER.		INCH.		PIT SAW.		CANT SAW.		CROSS CUT.		HOOK TOOTH.		Planer Knife.		Insert Tooth	
		2d Cut		2d Cut				Double Cut				Regul'r						Single Cut						Single Cut			
4		2.90		3.30		3		1.90				1.90		4		3.20											
5		3.20		3.50		3 1/2		1.90				1.90		5		3.50											
6		3.40		3.80		4		2.10				2.10		6		4.00											
7		3.90		4.30		4 1/2		2.30				2.30		7		4.50											
8		4.20		4.60		5		2.60				2.60		8		4.80											
9		4.90		5.40		5 1/2		3.00				3.00		9		5.80											
10		5.40		6.00		6		3.50				3.50		10		6.50											
11		6.50		7.30		7		4.20				4.20		11		7.70											
12		7.20		8.00		8		5.00				5.00		12		8.50											
13		9.00		10.00		9		6.00				6.00															
14		10.20		11.40		10		7.20				7.20															
15		12.50		13.90		11		9.00				9.00															
16		14.10		15.60		12		11.00				11.00															
17		17.00		18.90		13		13.00				13.00															
18		19.00		21.10		14		15.30				15.30															

INCH.		HORSE RASPS.		FILE RASPS.		INCH.		WOOD FILES.		WOOD RASPS.		INCH.		SHOE RASPS.		INCH.		KNIFE.	
		Plain	Bevered and 1/4 Edge	Flat	Hf. Rad			Hf. Rad		Hf. Rad				Hf. Rad					2d Cut
6		6.00		6		4.50		6.00		6		6.00		4		4.50	
7		6.90		7		5.20		6.90		7		6.90		5		5.00	
8		7.50		8		5.60		7.50		8		7.50		6		5.60	
9		9.10		9		6.30		9.10		9		9.10		7		6.30	
10		10.20		10		6.80		10.20		10		10.20		8		6.80	
11		12.50		11		8.00		12.50		11		12.50		9		7.90	
12		14.00		12		8.80		14.00		12		14.00		10		8.60	
13		16.70		13		10.50		16.70		13		16.70		11		10.20	
14		18.50		14		11.60		18.50		14		18.50		12		11.30	
15		22.10		15		13.50		22.10		15		22.10		13		13.40	
16		24.50		16		15.30		24.50		16		24.50		14		14.80	

INCH.		LAST MAKERS' RASPS.	
		One in. adv. on Cabinet Rasp.	
13		13.40	
14		14.80	

Sizes below 4 inches, not extended, take 4 inch price.
 Half inches not specified, take next higher full inch price.
 Dead Smooth, double the price of Bastard Cut.
 One Round Edge, advance 12 1/2 per cent.
 Cuts not specified, made upon regular blanks, advance one inch on respective kinds and nearest cut.
 Irregular Goods: all lengths above those listed, and files varying from standard sizes, to be classed as irregular and subject to special prices.

Blunt Files not specified, advance one inch on respective kinds and cuts.
 Single or Float Cut not specified, on regular shapes take Double Cut price.
 Equalings (Beiled), advance two inches on respective kinds and cuts.
 Two Round Edges, advance 25 per cent.

FILES

PLANER KNIFE FILE

(For Prices see File List, page 90)

JOWITT'S FILE LIST

Per dozen.

SIZE IN INCHES	4	4 1/2	5	6	7	8	9	10	11	12	13	14	15	16	18
Flat, Half-Round, Round, Square and Mill Saw Bastard	\$1.15	1.25	1.40	1.70	2.10	2.60	3.00	3.00	4.35	5.20	6.00	7.20	8.70	10.35	14.50
Flat and Half-Round, Second-cut and Second-cut Mill Saw	1.35	1.45	1.60	2.00	2.40	2.90	3.25	4.10	4.80	5.75	6.50	8.00	9.40	11.30	15.00
Flat and Half-Round, Round and Square Smooth, Cabinet Files and Rasps	1.65	1.80	2.00	2.30	2.80	3.30	3.75	4.00	5.55	6.40	7.20	8.70	10.10	12.50	17.80
Flat and Half-Round Dead Smooth	2.50	2.70	3.00	3.50	4.20	4.80	5.70	6.85	8.40	9.00	10.80	13.00	15.15	18.75	26.65
Hand Bastard and Warding	1.25	1.40	1.50	2.10	2.55	2.90	3.60	4.35	5.20	6.00	7.20	8.70	10.35	12.00	16.35
Hand Smooth	1.80	2.00	2.15	2.75	3.25	3.75	4.00	5.55	6.40	7.20	8.70	10.10	12.50	13.20	20.20
Knife Files, Bastard	2.00	2.30	2.55												
Half-Round Wood Rasps						2.00	3.00	3.00	4.35	5.20	6.00	7.20			
Round Wood Rasps							3.25								
Improved Shoe Rasps						2.05	3.25	4.00							
Horse Rasps												7.20	8.70	10.35	
Tanged Horse Rasps												10.35	12.00	14.50	
SIZE IN INCHES	3 1/2	4	4 1/2	5	5 1/2	6	7	8	9	10	11	12			
Taper Saw Files	0.95	1.10	1.20	1.35	1.55	1.80	2.30	2.90	3.75	4.70	5.75	7.00			
Band Saw Files	1.55	1.80	2.05	2.30	2.55	2.90									
Pit or Frame Saw Files	1.40	1.55	1.80	2.05	2.55	3.25	3.85	4.80	6.00	7.20					

EXTRAS—All Parallel Files to advance 1 inch on their respective descriptions. Equalling and Parallel Cotter Files Bastard to advance 1 inch on Flat Bastard prices. Mill Saw Files with 2 round edges to advance 1/4 inch.

"2 STUBS" FILE LIST

Per dozen.

SIZE IN INCHES	3	3 1/2	4	4 1/2	5	5 1/2	6	7	8
Saw Files, Taper or Blunt	1.25	1.35	1.55	1.75	2.00	2.20	2.45	3.10	4.40
Square and Taper Flat Bastard	1.50	1.65	1.75	2.15	2.25		3.25	4.00	4.50
Square and Taper Flat Smooth	1.75	2.00	2.25	2.75	3.00		4.00	5.00	6.00
Taper Flat, Super	2.75	3.00	3.25	3.75	4.00		5.00	6.00	7.00
Half-Round Bastard	1.75	2.00	2.50	2.75	3.00		4.00	4.50	5.00
Half-Round Smooth	2.00	2.40	2.75	3.15	3.50		4.50	5.50	6.00
Half-Round Super	2.75	3.00	3.50	4.00	4.50		5.50	7.00	8.00
Round Bastard	1.50	1.65	1.75	2.00	2.25		2.75	3.50	4.50
Round Smooth	2.00	2.25	2.50	2.75	3.00		4.00	5.00	6.00
Pottance Bastard	1.65	1.65	1.75	2.15	2.25		3.25	4.00	5.00
Pottance Smooth	1.90	1.90	2.25	2.75	3.00		4.00	5.00	6.00
Pottance Super	2.75	2.75	3.25	3.75	4.00		5.00	6.00	7.50
Equalling Smooth	2.00	2.00	2.25	2.75	3.00				
Knife Bastard	1.65	1.65	1.75	2.15	2.25				
Slitting "			3.00	3.25					
Warding "					2.00		3.00	3.75	
Cant Files					3.50				

F. L. GROBET'S SWISS FILE LIST

Per dozen.

SIZE IN INCHES	2 1/2	3	3 1/2	4	5	6	7	8
Hand, Flat, One Safe Edge	Nos. 2 and 4	2.20		2.50	2.90	3.70	4.00	
" " " "	" 5 " 6	2.20		2.50	3.75	4.00	4.00	
Pillar, Two Safe Edges	" 0 to 4	1.50		1.90	2.80	3.00	3.30	5.00
" " " "	" 5 and 6	1.50		2.00	2.90			
Pillar, Narrow, Two Safe Edges	" 2 to 4	1.50		1.90	2.80			
Taper Flat, or Entering, One Safe Edge	" 3 " 5	1.50		2.10	2.80			
Barrette, Tapering, Safe Back	" 3 " 5	1.50	1.70	2.10				
Half-Round, Tapering	" 3 " 5	1.50	1.70	2.25				
Crossing, Tapering, Oval	" 3 " 6	1.50	1.70	2.25	3.00			
Round, Tapering	" 1 " 6	.75	.75	1.10				
Square	" 3 " 6	1.00	1.00	1.00	1.30			
Triangular	" 2 " 5	1.80	1.80	1.80	2.25	2.80		

POLISHING PASTE AND SUPPLIES



Metal Polish for Cleaning and Burnishing Copper, Brass, Nickel, etc.

PUTZ POMADE

GENUINE ADALBERT VOGT & CO. Helmet Brand.					BOKER'S				
In tins.....	1 oz.	3 oz.	½ lb.	1 lb.		1 oz.	3 oz.	½ lb.	1 lb.
Per dozen	\$0.55	1.25	4.25	8.50		\$0.30	0.70	3.00	6.00

PUTZ EXTRACT

In tins.....			Medium	Large	1 lb.	5 lb.
Per dozen			\$0.95	1.40	6.80	30.20

BURNISHINE PASTE

In tins.....		No. 1	½ lb.	1 lb.	5 lb.
Per dozen		\$0.85	2.50	4.40	20.00

TRIPOLINE "MATCHLESS" METAL POLISH

Per dozen.....	½ lb.	1 lb. Tins.		Per pail.....	5 lb.	10 lb.	25 lb.	Pails.
	\$3.50	7.00			\$2.50	4.00	9.00	



OAKEY'S WELLINGTON KNIFE POLISH

In Canisters.

Nos.....		1	2	6	12
Per dozen.....		\$0.45	0.85	2.65	5.20

OAKEY'S PLATE POWDER

Non-Mercurial. Pink, in packages per dozen \$2.25

POLISHING SUPPLIES

For Cutting Down and Polishing Brass and other Metals.

Powdered American Tripoli, in barrels of 300 lbs.	per lb.
" " " less than barrel.....	"
Rouge, in kegs, 140 lbs.	"
" " " less than kegs.....	"
Crocus, No. 1, in kegs, 140 lbs.	"
" " " less than kegs.....	"
Crocus, No. 2, in kegs, 140 lbs.	"
" " " less than kegs.....	"

PURE TURKEY EMERY

Corn, 54 to 120	In 7 lb. packages. 10c. per lb.	Flour.....	(6c. per lb.
In kegs, about 300 lbs.			
Nos. 4 to 46, inclusive			price per 100 lbs.
" 54 to 160			"
Flour			"

QUARTZ

Flint or Quartz, Nos. ½, 1, 1½, 2, 2½	per 100 lbs.	\$6.75
---	--------------	--------

SAND, GARNET AND EMERY PAPER AND EMERY CLOTH

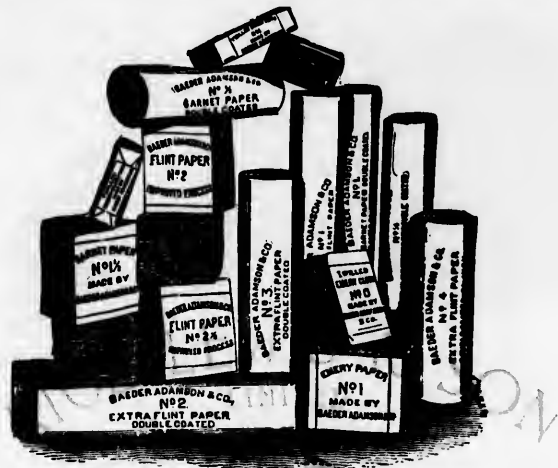

1/2 lb. 1 lb.
3.00 6.00

1 lb. 5 lb.
6.80 30.20

1 lb. 5 lb.
4.40 20.00

25 lb. Paits.
9.00

6 12
2.05 5.20

dozen \$2.25

per lb.
"
"
"
"
"
"

...6c. per lb.

lbs.
"

lbs. \$6.75

FLINT SAND PAPER IN SHEETS

Nos.....	00	0	1/2	1	1 1/2	2	2 1/2	3
Per ream.....	\$4.50	4.50	4.50	4.50	4.50	5.00	5.00	5.00
Bundle contains.....	5	5	4	3 1/2	3	2 1/2	2	1 1/2 reams

FLINT SAND PAPER IN ROLLS, 50 YARDS LONG

Nos.....	00	0	1/2	1	1 1/2	2	2 1/2	3
24 inches wide..... per roll	\$ 5.00	5.00	5.00	5.00	5.00	5.50	6.00	6.50
30 "..... "	8.00	8.00	8.00	8.00	8.00	9.00	10.00	11.00
36 "..... "	10.00	10.00	10.00	10.00	10.00	11.00	12.00	13.00
40 "..... "	12.00	12.00	12.00	12.00	12.00	13.00	14.00	15.00

GARNET PAPER IN ROLLS, 50 YARDS LONG

Nos.....	00	0	1/2	1	1 1/2	2	2 1/2	3
24 inches wide..... per roll	\$ 6.00	6.00	6.00	6.00	6.00	6.50	7.25	8.25
30 "..... "	9.00	9.00	9.00	9.00	9.00	10.00	11.00	12.00
36 "..... "	11.00	11.00	11.00	11.00	11.00	12.00	13.00	14.00
40 "..... "	13.00	13.00	13.00	13.00	13.00	14.00	15.00	16.00

EMERY PAPER IN SHEETS

Nos.....	00	0	1/2	1	1 1/2	2	2 1/2	3
Per ream.....	\$6.50	6.50	6.50	6.50	6.50	7.50	6.50	11.50
Bundle contains.....	4 1/2	4	3 1/2	3	2 1/2	2	1 1/2	1 1/2 reams

BEST AMERICAN TWILED EMERY CLOTH IN SHEETS

Nos.....	00	0	1/2	1	1 1/2	2	2 1/2	3	Cross Cloth
Comparative Nos. of Emery	Flour	120	100	80	70	60	54	46	Cloth
Per quire.....	\$0.90	0.90	0.90	0.90	0.90	1.00	1.20	1.30	0.90

5 quires in a package.

EMERY WHEELS



Different Shapes of Faces

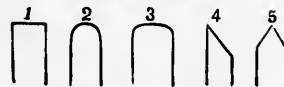

Other styles made to order

For all Wheels thinner than $\frac{1}{2}$ inch use list of $\frac{1}{2}$ inch.

N.B.—Wheels of any thickness between the dimensions below are listed the same as next size thicker. In ordering wheels give diameter and thickness of wheels and size of mandrel hole, description of work to be done and for what use, viz., wrought or cast iron, steel or brass, etc.

REVISED PRICE LIST OF EMERY WHEELS

Diameter of Wheels in Inches.	THICKNESS OF WHEELS IN INCHES.																No. of Revolutions per Minute
	1/2	3/4	1	1 1/4	1 1/2	1 3/4	2	2 1/4	2 1/2	2 3/4	3	3 1/4	3 1/2	3 3/4	4		
1 1/2	\$ 0 40	\$ 0 45	\$ 0 50	\$ 0 55	\$ 0 60	\$ 0 65	\$ 0 70	\$ 0 75	\$ 0 80	\$ 0 85	\$ 0 90	\$ 0 95	\$ 1 00	\$ 1 05	\$ 1 10	10000	
2	0 50	0 55	0 60	0 65	0 70	0 75	0 80	0 85	0 90	0 95	1 00	1 05	1 10	1 15	1 20	10000	
2 1/2	0 65	0 75	0 85	0 95	1 05	1 15	1 25	1 35	1 45	1 55	1 65	1 75	1 85	1 95	2 05	8000	
3	0 80	0 95	1 10	1 25	1 40	1 55	1 70	1 85	2 00	2 15	2 30	2 45	2 60	2 75	2 90	7400	
3 1/2	0 95	1 15	1 35	1 55	1 75	1 95	2 15	2 35	2 55	2 75	2 95	3 15	3 35	3 55	3 75	6400	
4	1 10	1 35	1 60	1 85	2 10	2 35	2 60	2 85	3 10	3 35	3 60	3 85	4 10	4 35	4 60	5450	
4 1/2	1 25	1 55	1 85	2 15	2 45	2 75	3 05	3 35	3 65	3 95	4 25	4 55	4 85	5 15	5 40	4900	
5	1 40	1 80	2 20	2 60	3 00	3 40	3 80	4 20	4 60	5 00	5 40	5 80	6 20	6 60	7 00	4400	
6	1 75	2 40	3 00	3 70	4 35	5 00	5 65	6 25	6 80	7 45	8 10	8 75	9 40	10 00	10 50	3900	
7	2 15	3 00	3 85	4 70	5 55	6 40	7 25	8 10	8 90	9 70	10 50	11 30	12 10	12 90	13 70	3150	
8	2 60	3 60	4 60	5 60	6 60	7 60	8 60	9 60	10 60	11 60	12 60	13 60	14 60	15 60	16 60	2750	
9	3 10	4 35	5 60	6 75	7 75	8 75	10 00	11 25	12 50	13 75	15 00	16 25	17 50	18 75	20 00	2450	
10	3 60	5 10	6 60	8 00	9 50	11 00	12 40	13 75	15 25	16 75	18 15	19 50	21 00	22 25	23 75	2200	
12	4 00	5 75	7 35	9 00	10 70	12 25	14 00	15 70	17 40	19 00	20 70	22 25	24 00	25 75	27 40	1850	
14	6 25	8 45	10 65	12 90	15 10	17 40	19 50	21 80	24 00	26 30	28 60	30 75	33 00	35 40	37 50	1600	
16	8 00	10 85	13 70	16 50	19 40	22 25	25 00	27 00	30 75	33 50	36 40	39 25	42 00	45 00	48 00	1400	
18	9 50	13 25	17 00	20 75	24 50	28 25	32 00	35 75	39 50	43 25	47 00	50 75	54 50	58 00	62 00	1250	
20	12 00	16 00	20 50	25 00	29 00	33 50	38 00	42 50	47 00	51 50	56 00	60 50	65 00	69 50	74 00	1100	
22	14 50	19 00	25 00	29 87	35 50	41 12	46 75	52 00	58 00	63 50	69 25	74 00	80 50	85 00	91 75	1000	
24	17 00	22 00	29 00	36 00	43 00	50 00	57 00	64 00	71 00	78 00	85 00	92 00	99 00	105 00	112 00	925	

FELT BUFFING WHEELS

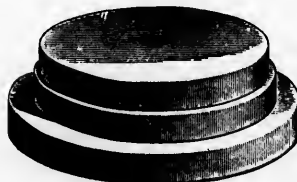

Size	6 x 1	8 x 1	8 x 1 1/2	10 x 1 1/2	10 x 2	12 x 2 inch.
Each	\$1.15	2.30	2.85	4.50	5.50	6.50

Hard, medium or soft grades.

GRINDSTONE FIXTURES

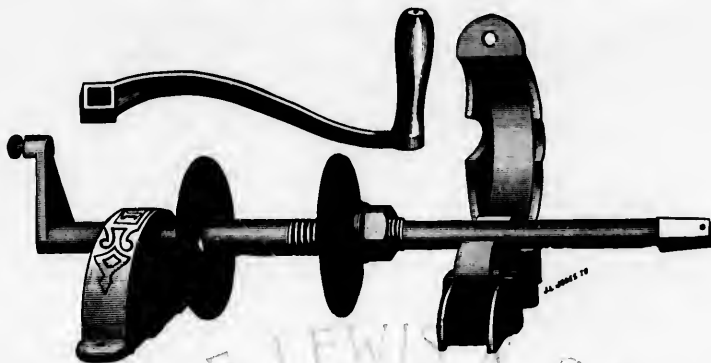

No. 1—Shaft, 15 inches long per doz. \$5.40
 " 2— " 17 " " 5.85

Packed six sets in a case.

MORSE PATENT TWIST DRILL GRINDING MACHINE WITH MILL AND SHELL REAMER GRINDING ATTACHMENT

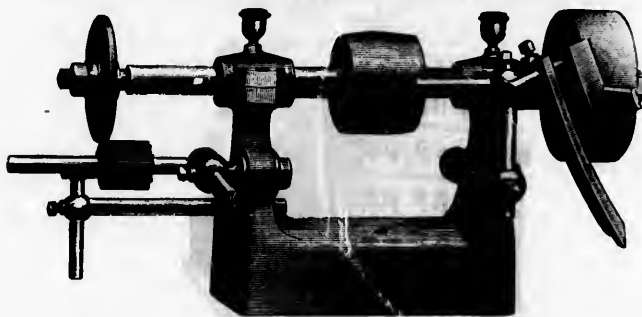

No. 139

No. 1, for sizes to $\frac{1}{2}$ in., including Emery Wheel \$18.75
 " 2, " $\frac{3}{8}$ in. to 2 in., with one Emery Wheel, and without Mill Attachment 57.90
 " 2, " $\frac{3}{8}$ " " 2 " " Mill Attachment and Emery Wheels 81.00

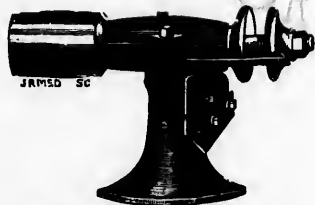

EMERY WHEEL GRINDERS

No. 1—This cut represents our Single Emery Grinder, for only one wheel, made to swing Emery Wheels from 3 to 9 inches; Steel Mandrel, $\frac{1}{2}$ inch diameter, bearing 5 inches long; Pulley, 3 inches diameter; $3\frac{1}{4}$ inch face; $1\frac{1}{4}$ inch space between collar to allow for Emery Wheel, unless ordered for extra length. Weight complete, with counter-shaft, 68 lbs. Price..... \$20.50

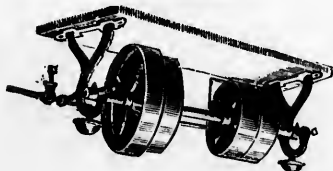

No. 2—Small Double Emery Grinder for Single Wheel on each side, made to swing Wheels from $2\frac{1}{2}$ to 8 inches; Steel Mandrel, $\frac{1}{2}$ inch diameter; bearing $2\frac{1}{2}$ inches long; Cone Pulley, 2 and 3 inches diameter, with $1\frac{1}{4}$ inch face. Weight complete, with counter-shaft, 48 lbs. Price..... \$24.50

ze thicker. In
to be done and

	No. of Revolutions per Minute
10	10000
20	10000
05	8000
90	7400
75	6400
60	5450
40	4900
00	4400
50	3800
70	3150
60	2750
00	2450
75	2200
40	1850
50	1600
00	1400
00	1250
00	1100
75	1000
00	925

12 x 2 inch.
6.50

GRINDSTONES

SIZES USUALLY STOCKED

Diameter.	14 to 16	16 to 18	18 to 20	20 to 22	24 to 26 inches.
Weights..	25 " 35	30 " 50	51 " 70	75 " 100	100 " 110 lbs.
Face.....	1½ " 2	1½ " 2½	2½ " 3	2½ " 3	2½ " 3½ inch.

Weight of Grindstones

RULE—Square the diameter (in inches); multiply by thickness (in inches); then by .00333; the product will be the weight of the stone in lbs.

Grindstones, under 200 lbs.	\$1.15 per 100 lbs.
" 200 to 1000 "	1.90 " " "
" over 1000 lbs.	price on application.



MOUNTED GRINDSTONES

SAMSON

Nos.....	1	2	3
Stone weighs...	100 to 110	70 to 80	40 to 50 lbs.
Each.....	\$4.00	3.75	3.50

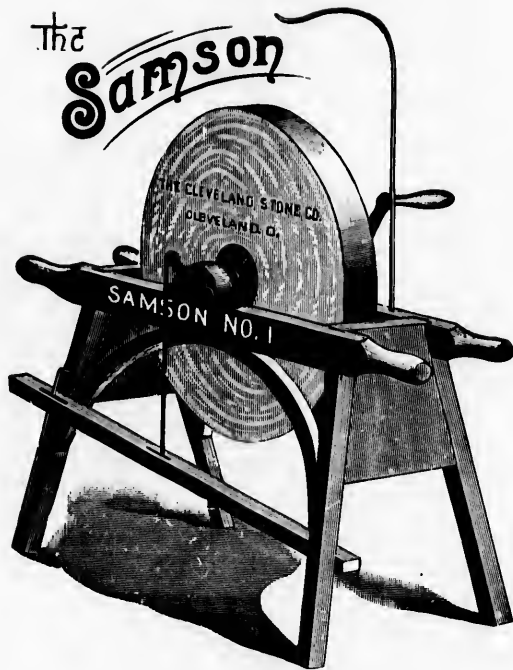

CCOKE

KITCHEN GRINDSTONES MOUNTED

Iron Frame and Wood Stand.

8 inch Diameter.....	per dozen	\$10.80
9 " " " " " " " " " "	" "	12.00

COOKE EMERY GRINDERS

6 x ¾ inch Emery Wheel.....	per dozen	\$16.50
-----------------------------	-----------	---------



KITCHEN GRINDSTONE

OIL STONES



Washita Oil Stones No. 1,	assorted sizes, in 10 lb. wooden boxes.....	per lb.	\$0.45
" " " "	Lilly White, " " " "	"	0.70
" " " "	Rosy Red, " " " "	"	0.70
" " " "	(Green paper), " " " "	"	0.00
Turkey " "	" " " "	"	0.00
Arkansas " "	" " " "	"	2.50
Hindustan " "	" " " "	"	0.10

24 to 28 inches.
100 " 110 lbs.
2 3/4 " 3 1/2 inch.

by thickness (in
of the stone in

1.15 per 100 lbs.
1.90 " " "

AXE STONES

Washita Axe Stones, in 5 lb. wooden boxes.....	per lb.	\$0.30
Hindustan " " " "	"	0.10
Deerlick " " " "	"	0.25
Water of Ayr " " one dozen in a package.....	"	0.12



Deerlick Oil Stones, 8 x 2 x 3/4, in 12 lb. wooden boxes..... per lb. \$0.35



WASHITA OIL STONES

MOUNTED

Size	8x2	7x2	6x2	5x2	4x1 1/2
Per dozen	\$12.00	11.00	10.00	9.00	7.00

DEERLICK OIL STONES

MOUNTED

Size	8x2	7x2	6x2	5x2
Per dozen	\$10.00	8.75	7.50	4.50

WASHITA OIL STONES

HANDLED

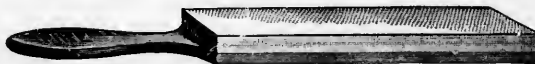

Size, 4 1/2 x 1, on Mahogany Handles..... per doz. \$4.00

ON GRINDSTONE

EMERY OIL STONES

A combination of Coarse and Fine Emery, quick cutting, and producing a fine edge.



Size	$4 \times 1\frac{1}{4}$	$4 \times 1\frac{1}{4}$	$5 \times 2\frac{1}{4}$ inch.
Per dozen	\$4.00	4.00	4.25



Style B, $3 \times 1 \times \frac{1}{4}$ inches.....per doz.	\$3.50	Style C, $4 \times 1\frac{1}{4} \times \frac{1}{4}$ inches.....per doz.	\$4.00
--	--------	---	--------



Style D, $6 \times 1\frac{1}{4} \times \frac{1}{4}$ inches.....per doz. \$5.75



Style E, $8 \times 2 \times 1$ inches.....per doz. \$9.00



Style G, $10 \times 3 \times 1$ inches.....per doz. \$15.00

OIL STONES



Washita Oil Slips, No. 1 ... in 5 lb. wooden boxes	per lb.	\$0.80
" " No. 2 ... " " 	"	0.50
" " Extra ... " " 	"	0.00
" " Lily White " " 	"	1.00
" " Rosy Red " " 	"	1.00
Turkey " 	"	1.00
Arkansas " No. 1 ... " " 	"	4.50
Deerlek " 	"	0.55
Hindustan " in 10 lb. " " 	"	0.20
Washita Oval Plug Stones	per doz.	4.40
" Round Plug Stones	"	5.00



Arkansas Flat Pieces, 3 to 4 inches long by $\frac{1}{4}$, $\frac{3}{8}$, $\frac{1}{2}$, $\frac{3}{4}$, $\frac{1}{2}$ and $\frac{3}{4}$ inch thick	per doz.	4.50
Washita " " 2 to 2 $\frac{1}{2}$ " " 1 x $\frac{1}{4}$ inch thick	"	1.10
" " 2 to 2 $\frac{1}{2}$ " " 1 x $\frac{1}{2}$ " " 	per lb.	0.80
Turkey " " 2 to 2 $\frac{1}{2}$ " " 1 x $\frac{1}{2}$ " " 	per doz.	1.20



Arkansas Knife Pieces, Sharp Edge, 3 to 4 inches long, $\frac{1}{4}$ inch wide, $\frac{3}{8}$, $\frac{1}{2}$, $\frac{3}{4}$, $\frac{1}{2}$ and $\frac{3}{4}$ inch back	per doz.	0.75
---	----------	------

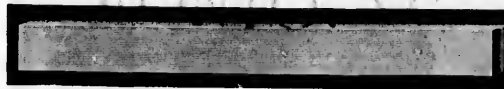

Arkansas Square Pieces, 4 inches long, by $\frac{1}{4}$, $\frac{1}{2}$ and $\frac{3}{4}$ inches	per doz.	4.50
--	----------	------



ARKANSAS CARVING TOOL SETS

Per Set of 4 Pieces	1.10
---------------------------	------

RAZOR HONES



Length.....		6	7	8 inch.
No. 1103	per doz.	\$5.00	6.85	17.75
“ 1103½	“	3.10	4.35
“ 44-OC	“	5.15
“ 44 —Hone Face Stones or Rubbers, about 4½ × 1 inch.....	per doz.	\$0.70		
“ 44C — “ “ “ “ “ “ 4½ × 1 “	“	1.25		
“ 100 — “ “ “ “ “ “ 4½ × 1 “	“	0.55		

Half-dozen in a package.

DEERLICK TABLE STONES



12 to 13 inches long..... per doz. 2.75

EMERY KNIFE SHARPENERS



No. 10 —Emery Knife Sharpeners, 12 inches long.....			per doz.	1.95
“ 11 — “ “ “ “ 15 “ “			“	2.25
“ 12 — “ “ “ “ 18 “ “			“	3.40

EMERY "MOWER'S FRIEND"



No. **8**—Mower's Friend, Wire Strengthened..... per doz. 2.75

EMERY SCYTHE STONES



No. **7**—Emery Scythe Stones, Wire Strengthened..... per doz. 2.75

Three dozen in a box.

LIQUID FISH GLUE

For Carriage, Cabinet Makers, Carpenters
and Mechanics generally.



In Bottles, Small Family.....	per gross	\$10.00
“ “ Large “	“	16.00
“ Tin Cans, Half-Gills	“	18.00
“ “ “ Gills	“	24.00

In gross and half-gross cases.

Tin Cans, Half-Pints.....	per doz.	3.00
“ “ Pints	“	5.00
“ “ Quarts	“	0.00
“ “ Half-Gallons	“	15.00
“ “ Gallons	“	27.00

Half-Pints, two dozen in a case, Pints and Quarts,
one dozen; Half-Gallons and Gallons, half dozen.

GENUINE LEPAGE'S LIQUID GLUE

In gallon tins.....per doz. \$36.45

GLUE

No. HHB—White, Broken Sheet, suitable for Furniture Work and Wood Work generally.....	per lb.	0.18
“ 41365— “ “ “ “ Emery “ “ “ “	“	0.15
“ HFB—Amber, “ “ “ “ Paper Box and Bag Manufacturers and Sizing.....	“	0.14
“ FDB— “ “ “ “ Cheap Paper Boxes and Bags and Cheap Sizing.....	“	0.12½
“ HBB— “ “ “ “ Brush Manufacturers, Cheap Sizing and Compo. Work.	“	0.10½

WATERPROOF MARINE GLUE

For Canking Decks, Top, Sides and Bottom of Yachts, etc.

In 14 and 28 lb. boxes.....per lb. 0.50



GLUE POTS

Nos.....	8-0	6-0	4-0	2-0	0	1	2	3	4	5
Capacity..	½	¾	1	1	1½	1½	2	2½	3	3½ pints.
Per dozen	\$3.60	4.30	5.70	7.15	7.85	9.00	11.10	13.60	16.40	19.90
Handy Family Glue Pot with Lid.....										per doz. \$4.50

HARD RUBBER CEMENT

For Cementing Rubber to Wood, Iron, etc.

1 lb. Packages.....per lb. 0.50
1/8 lb. “.....per doz. 1.80

RUBBER SOLUTION

For Repairing and Patching Sheet Rubber.

In tubes.....	3½ x ¾	6 x 1½	In tins.....	½ pt.	1 pt.	1 qt.	1 gal.
Per dozen.....	\$0.75	3.00	Per tin.....	\$0.20	0.40	0.80	2.25

BORAX

Refined, Crystals.....per lb. 0.00½
“ Powdered.....“ 0.10

"DUDGEON" PATTERN TUBE EXPANDERS

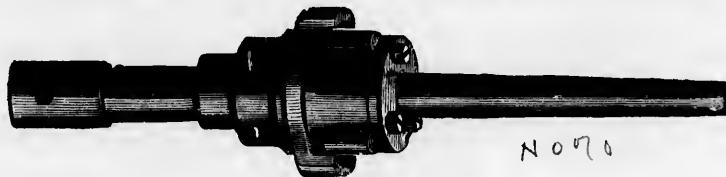

N 070

Size	1	1 1/4	1 1/2	1 3/4	2	2 1/4	2 1/2	2 3/4	3	3 1/4	3 1/2	4 inch.
Price.....each	\$5.00	5.00	5.25	5.25	5.60	5.60	6.30	7.00	7.80	8.75	10.00	12.00



OPENED

PAT'D
JAN 16, 1889

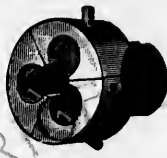

CLOSED

EXTENSION AND SELF-FEEDING TUBE EXPANDERS

N 070

No. 1 expands 1 1/4 to 1 3/4 inch	each	\$15.50
" 1 1/2 " " 1 1/2 to 2 1/4 "	"	18.00
" 2 " " 2 to 3 "	"	22.00
" 2 1/2 " " 2 1/2 to 3 1/4 "	"	25.00
" 3 A " " 3 1/4 to 4 "	"	25.00
" 3 " " 3 1/4 to 5 "	"	33.00

TUBE CLEANERS



O C 7 070

INGALS' TUBE CLEANER

For Flues	2	2 1/4	2 1/2	2 3/4	3	3 1/2	4 inch
Price	each	\$2.00	2.25	2.50	2.75	3.00	3.50 4.00

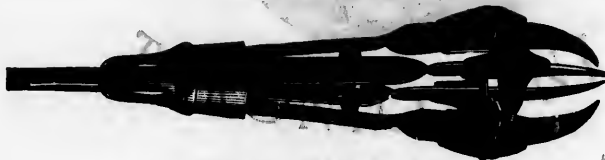

NATIONAL TUBE CLEANER

N 070

For Flues	1 1/2	1 3/4	2	2 1/4	2 1/2	2 3/4	3	3 1/2	4 inch.
Price	each	\$2.00	2.00	2.00	2.25	2.50	2.75	3.00	3.50 4.00



ENGINEERS' FAVORITE TUBE CLEANER

For Flues..	2	2 1/4	2 1/2	2 3/4	3	3 1/4	4 inch.
Price..each	\$2.00	2.25	2.50	2.75	3.00	3.50	4.00



STEEL WIRE FLUE CLEANER

L 11070

For Flues.....	1 1/4	1 1/2	2	2 1/4	3	4 inch.
Price	each	\$2.00	2.00	2.00	2.00	2.00

PATENT IMPROVED SPEED INDICATORS

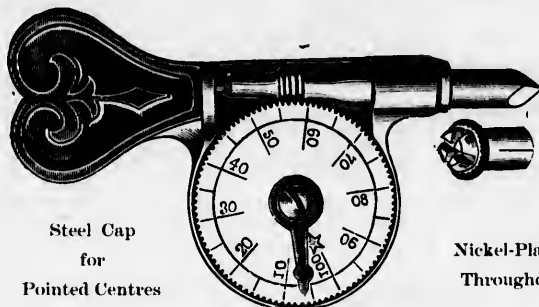

Steel Cap
for
Pointed Centres

Nickel-Plated
Throughout

No. 100

No. 100—Price Plain Capeach \$1.00
 " 101— " Split " 1.20



STARRETT'S
HIGH SPEED INDICATOR No. 104

The working parts of this instrument are of figures, reading right or left. The innering gear by a checked wafer head screw, by plate is loosened, when the O mark may be

increased, and the dial plate has two rows plate is frictionally clamped to the revolva pressure and twist with the thumb the instantly moved to the starting point.

No. 104each \$1.50



This instrument is nickel-plated, and has reading right and left. The dial is locked twist on the knurled eccentric releases it so that agree with the starting point.

rosewood handle, has two rows of figures to a revolving stud, a slight pressure and that the indicator may be moved and locked

No. 106each \$2.25

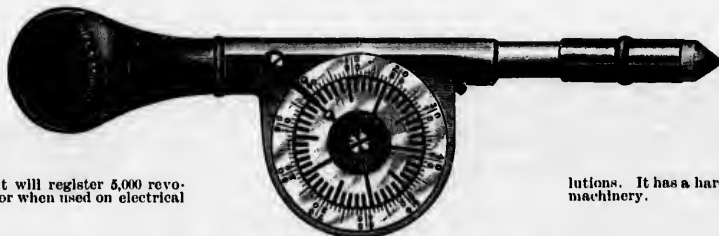

This instrument will register 5,000 revolving a safe insulator when used on electrical

lutions. It has a hard rubber handle mak-machinery.

REGISTERING HIGH SPEED INDICATOR

No. 107each \$4.50

WEISS DOUBLE ALARM SPEED INDICATOR



A Bell placed at the back of the Dial rings at every hundred revolutions of the spindle.

Price.....each \$1.00

..... " 1.20

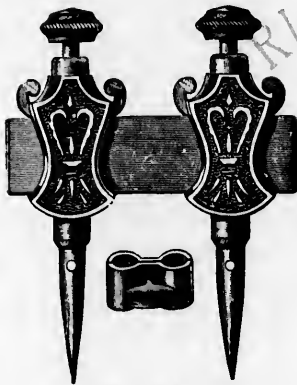

Nos. 1, 2 and 3

IMPROVED TRAMMEL POINTS

Bronze Metal, with Steel Points and Pencil Holder.

Nos.....	1	2	3	
Length.....	2 $\frac{1}{4}$	4	4 $\frac{1}{2}$	inch.
Price.....	\$1.00	1.25	1.75	per pair

One pair in a box.

STANLEY'S PATENT RULE TRAMMEL POINTS

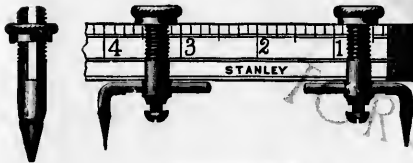

A complete set consists of two Brass Trammel Heads with movable steel points and one head with a Pencil Socket. They can be attached to folding rules of any ordinary width.

No. 99. Per set of 3 in a box..... \$0.60

EXCELSIOR PENCIL HOLDER

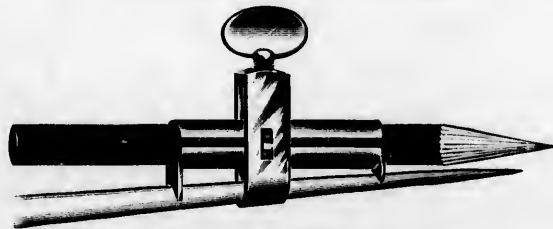

Can be attached to any Divider or Compass.

Per dozen..... 2.50

SPRING DIVIDERS

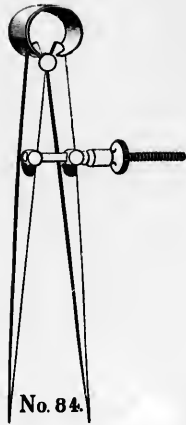

No. 84.



No. 83.

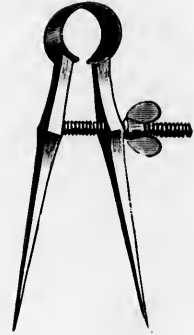

No. 8170

Size	2½	3	4	5	6	7	8 inch.
No. 84	each	\$0.80	0.90	0.95	1.00	1.05	1.40
" 83	"	1.00	1.05	1.15	1.20	1.25	1.55
" 8170, Boker's.....	"	0.45	0.50	0.80

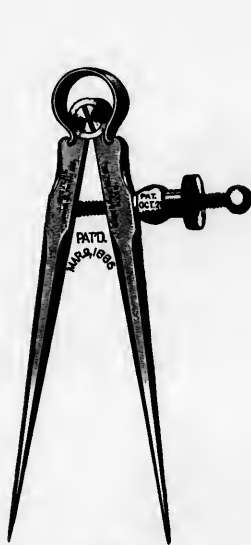

No. 66.

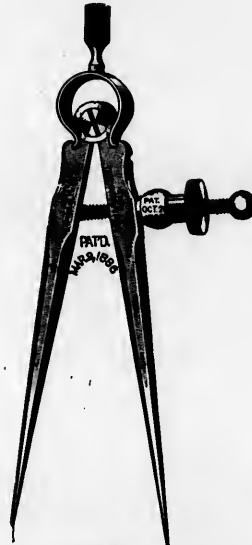

No. 67.



No. 44.



No. 45.

Length.....	2½	3	4	5	6 inch.
No. 66.....	each	\$1.25	1.55	1.55	1.90
" 67.....	"	1.45	1.75	2.20
" 44.....	"	\$0.80	0.90	0.95	1.00
" 45.....	"	1.00	1.05	1.15	1.20

SPRING CALIPERS



No. 74.

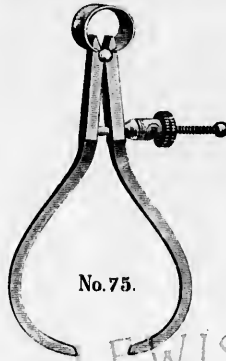

No. 75.



No. 76.

WITH SPRING NUT

Size.....	2½	3	4	5	6 inch.
No. 74.... each	\$1.45	1.55	1.55	1.90
" 75.... "	\$1.45	1.45	1.55	1.55
" 76.... "	1.45	1.55	1.55

WITH SOLID NUT

Size.....	2½	3	4	5	6 inch.
No. 74.... each	\$1.25	1.40	1.40	1.70
" 75.... "	\$1.25	1.25	1.40	1.40
" 76.... "	1.25	1.40	1.40

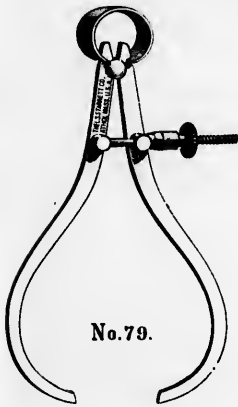

No. 79.



No. 73.

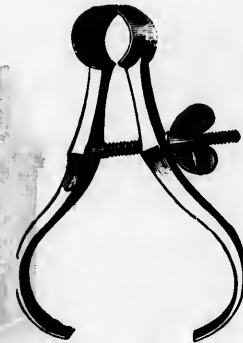

No. 8171

Size.....	2½	3	4	5	6	7	8 inch.
No. 79 or 73—With Spring Nut..... each	\$1.10	1.20	1.25	1.30	1.40	1.55
" 79 or 73— " Solid "..... "	0.90	0.90	0.95	1.00	1.05	1.25
" 8171—Boker's, with Solid Nut.. "..... "	0.50	0.55	0.65

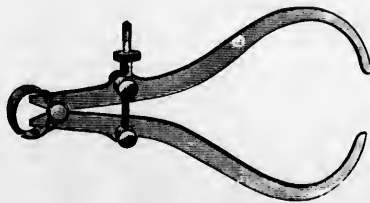

No. 39

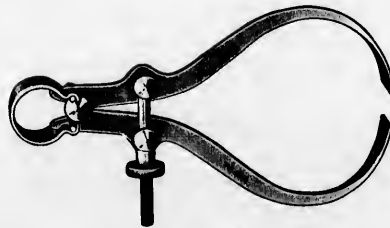

No. 40

Size.....	3	4	4½	5	6	8 inch.
No. 39—Outside Spring Caliper..... each	\$0.90	0.95	1.00	1.00	1.05	1.25
" 40—Thread Caliper..... "	\$0.95	1.15	1.25

IMPROVED FIRM-JOINT CALIPERS

LOCK-JOINT TRANSFER CALIPERS

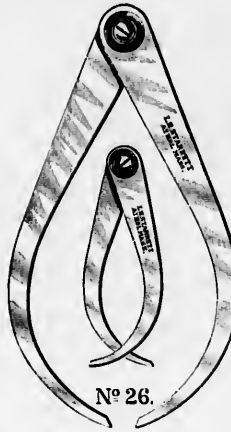

No. 26.

PRICES

Nos. 26 and 27

3 inch... each	\$0.50
4 " " " "	0.65
5 " " " "	0.70
6 " " " "	0.80
8 " " " "	1.00
10 " " " "	1.05
12 " " " "	1.25
14 " " " "	1.00
16 " " " "	2.20
18 " " " "	2.60
20 " " " "	3.10
24 " " " "	3.75

The above sizes refer to the length of the Calipers.

Their capacity is about one-third greater than the size given.



No. 27.



No. 36

PRICES

Nos. 36 and 37.

4 inch... each	\$1.55
5 " " " "	1.75
6 " " " "	1.90
8 " " " "	2.20
10 " " " "	2.60
12 " " " "	2.80
14 " " " "	3.15
16 " " " "	3.45
18 " " " "	3.75
20 " " " "	4.40
24 " " " "	5.30



No. 37

LOCK-JOINT CALIPERS AND DIVIDERS

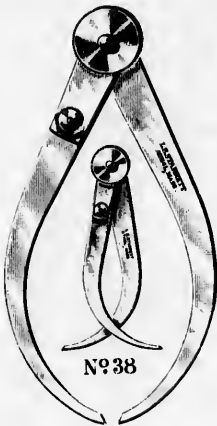

No. 38

PRICES

Nos. 38 and 39.

4 inch... each	\$1.15
6 " " " "	1.25
8 " " " "	1.55
10 " " " "	1.90
12 " " " "	2.20
14 " " " "	2.50
16 " " " "	2.80
18 " " " "	3.10
20 " " " "	3.45
24 " " " "	4.40



No. 39



No. 41

PRICES

No. 41

3 inch.....	each	\$0.50
4 " " " "	" "	0.65
5 " " " "	" "	0.70
6 " " " "	" "	0.80
8 " " " "	" "	1.00
10 " " " "	" "	1.15
12 " " " "	" "	1.25

No. 43

6 inch.....	each	\$1.25
8 " " " "	" "	1.55
10 " " " "	" "	1.90



No. 43



No. 77.

SPRING DIVIDERS

2½ inch, each, with Spring Nut	\$1.45..	with Solid Nut	\$1.25
3 " " " "	1.45..	" " " "	1.25
4 " " " "	1.75..	" " " "	1.55
5 " " " "	1.75..	" " " "	1.55
6 " " " "	2.20..	" " " "	1.90

Dividers, No. 77, all sizes, are sent with Spring Nut unless otherwise ordered.

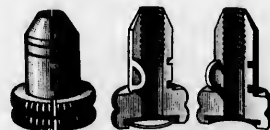

SPRING NUT

CALIPERS



0.55
0.75
0.90
1.20
1.50
1.80
2.15
2.45
2.75
3.40
4.30

No. 37



\$0.50
0.65
0.70
0.80
1.00
1.15
1.25

No. 43

Slid Nut \$1.25
" " 1.25
" " 1.55
" " 1.55
" " 1.90

CALIPERS

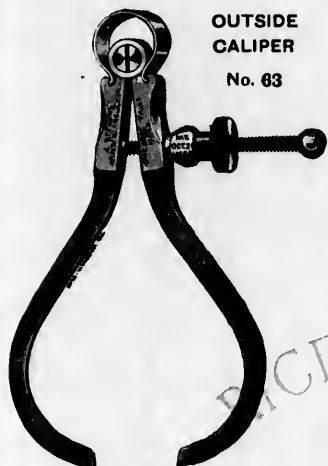

OUTSIDE
CALIPER
No. 63

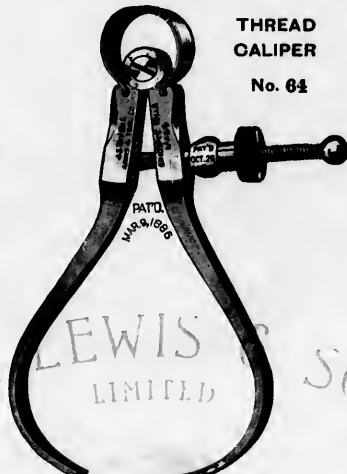

THREAD
CALIPER
No. 64



KEY-HOLE
CALIPER
No. 68

Size		2½	3	4	5	6 inch.
No. 63	each	\$1.25	1.25	1.55	1.55	1.90
" 64	"	1.25	1.55
" 68	"	1.45	1.90

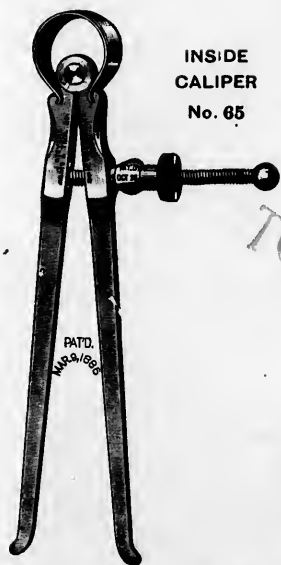

INSIDE
CALIPER
No. 65

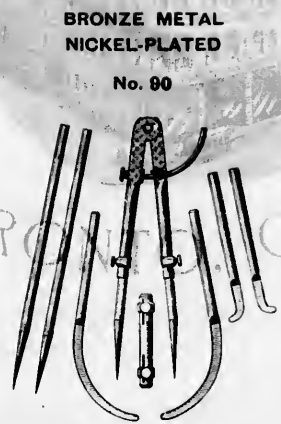

BRONZE METAL
NICKEL-PLATED
No. 90

No. 65—3 inch.....	each	\$1.25
4 "	"	1.55
5 "	"	1.55

The Head with short point is eight inches long; may be extended two inches more; will caliper 10 inches outside and 12 inches inside.

No. 90—With short points only	each	\$3.40
Set complete ..	"	6.00



No. 85—7 inch, with Divider		
Legs only.....	each	\$1.55
9 inch, with Divider		
Legs only	each	1.90
7 inch, complete ..	"	2.80
9 " " " "	"	3.75

CALIPERS AND DIVIDERS



No. 50

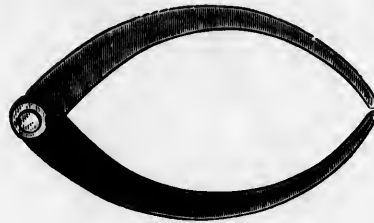

No. 1545 $\frac{1}{2}$

Size	3	4	5	inch.
No. 1545 $\frac{1}{2}$ per doz.	\$2.00	2.00	2.00	



No. 1594

Size.....	5	6	7	8	9	10	12	inch.
No. 50..... per doz.	\$2.00	2.90	3.45	3.95	4.75	5.25	6.30	
" 1594..... "	\$2.00	2.40	

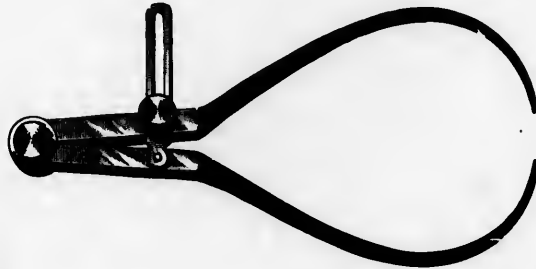

Size.....	5	7	9	inch.
No. 250..... per doz.	\$6.00	7.50	9.00	



No. 7

Size.....	4	6	8	inch.
No. 7..... per doz.	\$6.00	7.50	10.50	



No. 60

Size.....	6	8	10	12	inch.
No. 60..... per doz.	\$4.55	5.85	7.15	8.45	

CALIPERS

FIRM JOINT CALIPERS

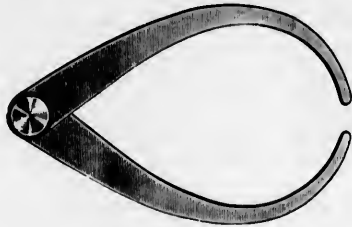

No. 41
 Size..... 4 6 8 10 inch.
 No. 41.....each \$0.65 0.80 1.00 1.25

FIRM JOINT CALIPERS

With Screw Adjustment.

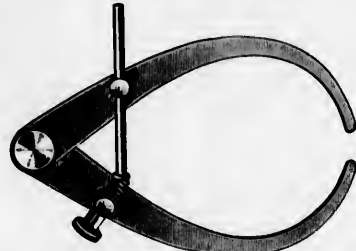

No. 42
 Size..... 4 6 8 10 inch.
 No. 42.....each \$0.95 1.15 1.30 1.55

COMBINATION CALIPER AND DIVIDER

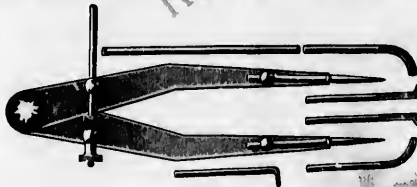

No. 47
 Size..... 4 6 8 10 inch.
 No. 47.....each \$2.50 2.80 3.10 3.45

HERMAPHRODITE CALIPER



No. 48
 Size..... 4 6 8 10 inch.
 No. 48.....each \$0.95 1.25 1.55 1.90

OUTSIDE CALIPERS

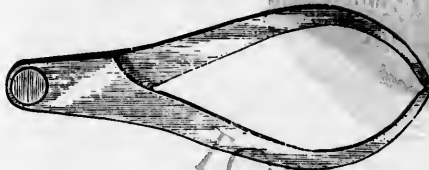

No. 13
 Size..... 2 3 4 6 8 12 18 24 inch.
 Per doz. \$2.25 2.60 2.90 3.50 5.25 7.25 20.00 30.00

INSIDE CALIPERS



No. 14
 Size..... 2 3 4 6 8 12 24 inch.
 Per doz. \$2.25 2.60 2.90 3.50 5.25 7.25 30.00

REGISTERING CALIPERS

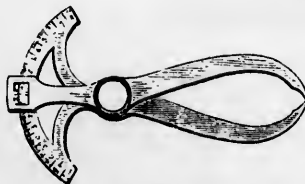

No. 1566
 Size..... 5 7 inch.
 No. 1566.....each \$1.25 1.85

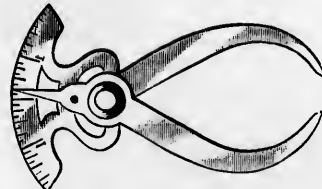

No. 165
 Size..... 3 4 5 inch.
 No. 165.....each \$0.70 0.85 1.00

MATHEMATICAL SETS



No. 4200

- No. **4200**—6 pieces, viz.: 1 pair $3\frac{1}{2}$ inch Dividers, with Pen and Pencil Attachments; 1 Pencil Holder, Wrench and Scale. In Velvet Lined, Polished Wood Case..... each \$0.00
- No. **4217**—6 pieces, viz.: 1 pair $4\frac{1}{2}$ inch Dividers, with Pen and Pencil Attachments; 1 Pencil Holder, Wrench and Ink Cup. In Velvet Lined, Leather Covered Case each 0.80

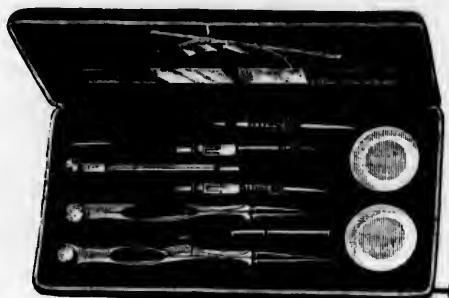

No. 4232

- No. **4232**—12 pieces, viz.: 1 pair $4\frac{1}{2}$ inch Plain Dividers; 1 pair 5 inch Dividers, with Pen, Pencil and Lengthening Bar; 1 Drawing Pen, Quadrant, Boxwood Straight Edge and Corner Square; 2 Ink Cups. In Velvet Lined, Leather Covered Case each 1.85
- No. **4230**—12 pieces, viz.: 1 pair $4\frac{1}{2}$ inch Plain Dividers; 1 pair 5 inch Dividers, with Pen, Pencil and Lengthening Bar; 1 Drawing Pen, German Silver Protractor Scale, Pencil Holder and Wrench, Handles Nickel-plated. In Velvet Lined, Leather Covered Case each 2.65



No. 4237

- No. **4237**—10 pieces, viz.: 1 pair $5\frac{1}{2}$ inch Dividers, with Thumb Attachment, Pen, Pencil and Lengthening Bar; 1 pair $5\frac{1}{2}$ inch Plain Dividers, with Thumb Attachment; 1 pair $3\frac{1}{2}$ inch Pen Dividers, with Thumb Attachment; 1 Drawing Pen, Pencil Holder and Wrench, German Silver Protractor Scale, Handles Nickel-plated, Dividers with Adjustable Needle Points. In Velvet Lined, Leather Covered Case each 5.70
- No. **4238**—15 pieces, viz.: 1 pair $5\frac{1}{2}$ inch Dividers, with Pen, Pencil and Lengthening Bar; 1 pair $5\frac{1}{2}$ inch Plain Dividers; 1 pair $3\frac{1}{2}$ inch Dividers, with Thumb Attachment and Pen and Pencil Pieces; 1 pair 3 inch Pen Dividers, with Thumb Attachment; 1 each $4\frac{1}{2}$ and 5 inch Ivory Handled Pencil Holder and Wrench, Handles Nickel-plated. In Velvet Lined, Leather Covered Case each 8.85

TWIST DRILL AND STEEL WIRE GAUGE

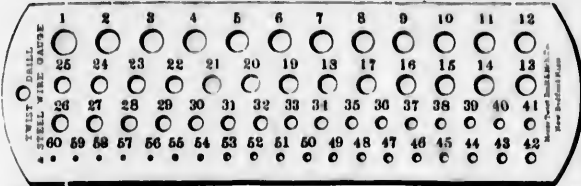

No. 774—Gauge numbers from 1 to 43each \$2.25
This gauge is used for measuring Twist Drills and Stub's Steel Rods.

Holder, ...each \$0.80
Holder, ...each 0.80

JOBBER'S' DRILL GAUGE

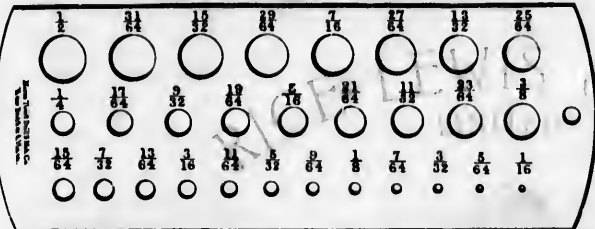

No. 775—Sizes from 1/16 to 1/2 incheach \$4.00

SIZES OF THE NUMBERS OF TWIST DRILL AND STEEL WIRE GAUGE

No.	Size of Number in Decimals.	No.	Size of Number in Decimals.
1	.2280	31	.1300
2	.2210	32	.1180
3	.2130	33	.1130
4	.2060	34	.1110
5	.2005	35	.1100
6	.1940	36	.1085
7	.1890	37	.1040
8	.1860	38	.1015
9	.1800	39	.0985
10	.1835	40	.0980
11	.1810	41	.0960
12	.1800	42	.0935
13	.1850	43	.0890
14	.1820	44	.0880
15	.1800	45	.0820
16	.1770	46	.0810
17	.1730	47	.0785
18	.1685	48	.0780
19	.1660	49	.0730
20	.1610	50	.0700
21	.1560	51	.0675
22	.1570	52	.0635
23	.1540	53	.0595
24	.1520	54	.0550
25	.1485	55	.0520
26	.1470	56	.0485
27	.1440	57	.0430
28	.1405	58	.0430
29	.1390	59	.0410
30	.1285	60	.0400

WIRE GAUGES



No. 611



No. 848



No. 1110

No. 611, Wynn's Round Wire Gauge, sizes 1 to 30, English Standardeach \$3.00
 " 730, Brown & Sharpe " " " 0 to 36, American " " 3.75
 " 732, " " " " 5 to 36, " " " 3.00
 " 734, " " " " 1 to 36, English " " 3.00
 " 736, " " " " 0 to 36, " " " 2.25
 " 848, Wynn's Double Round " " 1 to 30, " " " 3.50
 " 1110, " Oblong " " 1 to 25, " " " 3.00
 " 292, Stub's " " " 1 to 36, " " " 3.96

...each 1.86
...each 2.65

OF WIRE GAUGE SIZES

Number of Wire Gauge.	American or Brown & Sharpe.	Birmingham or Stub's Wire.	Number of Wire Gauge.	American or Brown & Sharpe.	Birmingham or Stub's Wire.
000000			18	.040908	.049
00000			19	.03580	.042
000	.46	.454	20	.031961	.035
00	.4004	.425	21	.028462	.032
0	.3648	.38	22	.025347	.028
1	.32489	.34	23	.022571	.025
2	.2893	.3	24	.0201	.022
3	.25763	.284	25	.0179	.02
4	.22942	.250	26	.01594	.018
5	.20431	.238	27	.014195	.016
6	.18194	.22	28	.012641	.014
7	.16202	.203	29	.011257	.013
8	.14428	.18	30	.010025	.012
9	.12849	.165	31	.008928	.011
10	.11443	.148	32	.00795	.009
11	.10189	.134	33	.00708	.008
12	.090742	.12	34	.006304	.007
13	.080808	.109	35	.005614	.006
14	.071961	.095	36	.005	.004
15	.064084	.083	37	.004453	
16	.057068	.072	38	.003965	
17	.05082	.065	39	.003531	
	.045257	.058	40	.003144	

TABLES OF DECIMAL EQUIVALENTS

OF FRACTIONAL SIZES			
1/16 = .0625	3/16 = .1875	5/16 = .3125	7/16 = .4375
1/8 = .125	3/8 = .375	1/2 = .5	5/8 = .625
3/8 = .375	7/8 = .875	1 = 1.0	
1/4 = .25	1/2 = .5	3/4 = .75	
5/16 = .3125	3/8 = .375	7/8 = .875	
3/8 = .375	1/2 = .5	5/8 = .625	
1/2 = .5	3/4 = .75	5/8 = .625	
3/4 = .75	5/8 = .625	3/4 = .75	
5/8 = .625	3/4 = .75	1 = 1.0	
3/4 = .75	1 = 1.0		
1 = 1.0			
1.125 = 1 1/8			
1.25 = 1 1/4			
1.375 = 1 3/8			
1.5 = 1 1/2			
1.625 = 1 5/8			
1.75 = 1 3/4			
1.875 = 1 7/8			
2.0 = 2			
2.125 = 2 1/8			
2.25 = 2 1/4			
2.375 = 2 3/8			
2.5 = 2 1/2			
2.625 = 2 5/8			
2.75 = 2 3/4			
2.875 = 2 7/8			
3.0 = 3			

OF MILLIMETERS AND FRACTIONS OF MILLIMETERS

1 mm. = .03937 inch.

mm.	inches.	mm.	inches.	mm.	inches.
1	.03937	11	.43307	21	.82677
2	.07874	12	.47244	22	.86614
3	.11811	13	.51181	23	.90551
4	.15748	14	.55118	24	.94488
5	.19685	15	.59055	25	.98425
6	.23622	16	.62992	26	1.02362
7	.27559	17	.66929	27	1.06299
8	.31496	18	.70866	28	1.10236
9	.35433	19	.74803	29	1.14173
10	.39370	20	.78740	30	1.18110
11	.43307				
12	.47244				
13	.51181				
14	.55118				
15	.59055				
16	.62992				
17	.66929				
18	.70866				
19	.74803				
20	.78740				
21	.82677				
22	.86614				
23	.90551				
24	.94488				
25	.98425				
26	1.02362				
27	1.06299				
28	1.10236				
29	1.14173				
30	1.18110				

10 mm. = 1 Centimeter = 0.3937 in.
 10 cm. = 1 Decimeter = 3.937 "
 10 dm. = 1 Meter = 39.37 "
 25.4 mm. = 1 English Inch.

...each 5.70
...each 8.86

IMPROVED COMBINATION SURFACE GAUGE

CARR'S PATENT

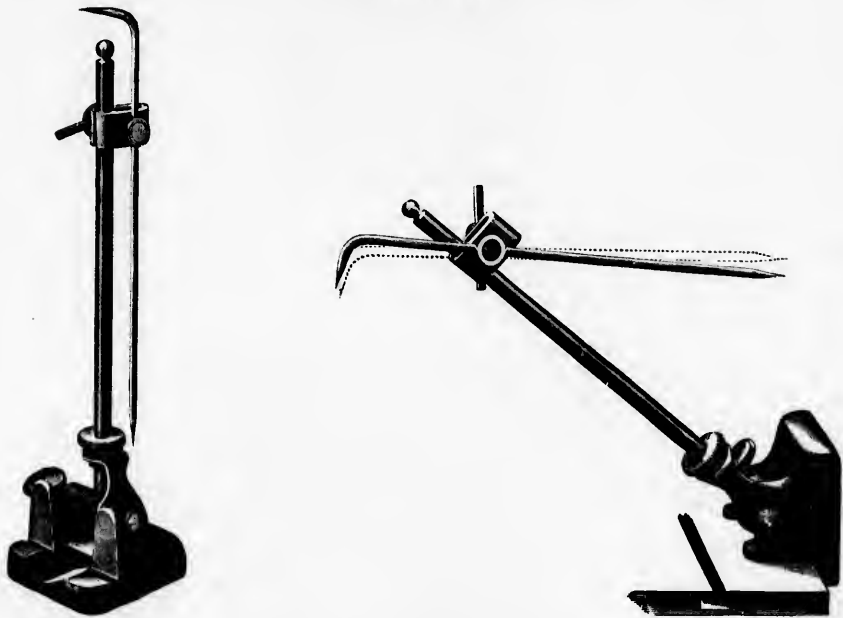

These gauges are made of the best material and workmanship and are finely finished. It has a fine adjustment of $\frac{1}{4}$ to $\frac{3}{8}$ inch, operated by the eccentric washer at the base of the shaft.

No. 2, furnished with two spindles, making a 12 and 18 inch gauge each \$4.50

CARR'S PATENT COMBINATION SCRIBING BLOCK

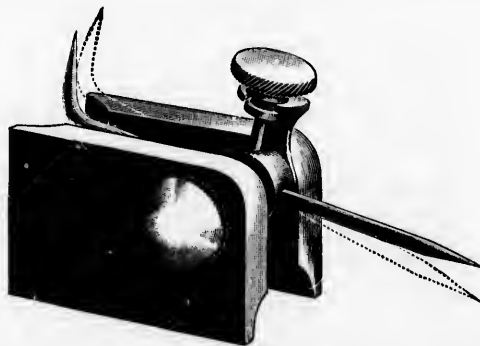

No. 43

This tool fills a want for a neat and convenient Scribing Block that can quickly be adjusted to the finest work. It contains the patented fine adjustment similar to that on our surface gauge, the needle being set in any position and held perfectly rigid by the side thumb nut while using the fine adjustment, by means of the eccentric thumb washer on top. It has a V-slot in the bottom of base by which work can be quickly and accurately tried to a boring bar. It also makes a useful and convenient scratch and depth gauge.

No. 43 each \$2.65

SURFACE GAUGES

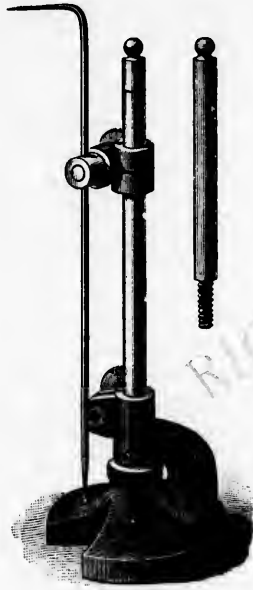

No. 52



No. 53

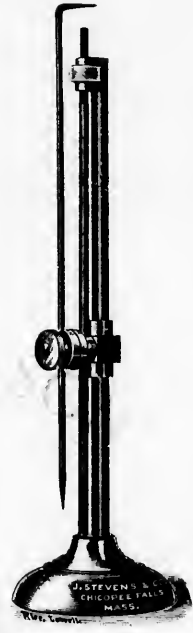

No. 59

Size.....		8	12		12 inch.
No. 52—Starrett's Surface Gauges.....	each	\$2.50	3.45	with 6 in. extension	4.05
“ 53— “ “ “.....	“	3.75	5.05	“ “	6.00
“ 59—Stevens’ “ “.....	“	2.50	3.50	

TOOL-MAKERS' UNIVERSAL SURFACE GAUGES

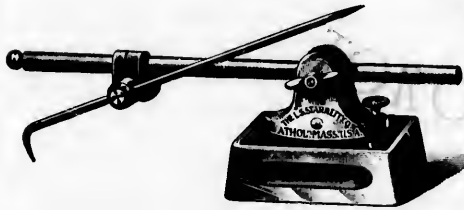

No. 55

This Gauge has the following improved features, viz.: joint at the base which allows the spindle and scriber to be moved back and forth and placed in any position from upright to horizontal to reach over, back of and under work that could not be got at with old style gauges, while by inclining the spindle over the work its scope for long reach is increased.

No. 55—9 inch		each	\$3.75
12 “	“		4.50
With two spindles 12 and 18 in.....	“		5.25



No. 56

This little tool is made on the principle of No. 55. The base is steel, nicely finished and *case-hardened*, with depressions milled in the sides for the thumb and finger to grasp. The top side of it is slotted, and the rocking bracket is pivoted in the same. There is a stiff spring under one end of the bracket and a knurled adjusting screw in the other. It weighs but 11 ounces and is 5 inches high, and, folding the spindle (which is 4 inches long) horizontally over the base, it may be packed in 1 7/8 x 1 1/4 x 4 inches space in the tool chest.

No. 56		each	\$4.50
--------------	--	------	--------

IMPROVED SCREW PITCH GAUGES

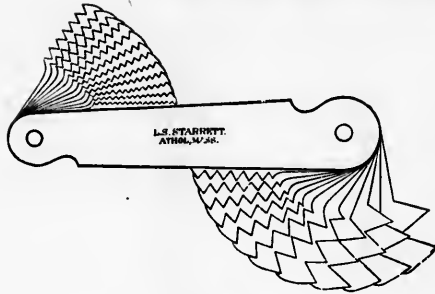

No. 4

24 Pitches, 4 to 30. Cut Full Size.

Has the following pitches: 4, 4½, 5, 5½, 6, 7, 8, 9, 10, 11, 11½, 12, 13, 14, 15, 16, 18, 20, 22, 24, 26, 27, 28, 30. The teeth are sharp and clean cut.each \$1.00

No. 5

26 Pitches, 32 to 82.

Of the same form as our No. 40 Screw Pitch Gauge, for inside and outside work. Has the following pitches: 32, 34, 36, 38, 40, 42, 44, 46, 48, 50, 52, 54, 56, 58, 60, 62, 64, 66, 68, 70, 72, 74, 76, 78, 80, 82.each \$1.00

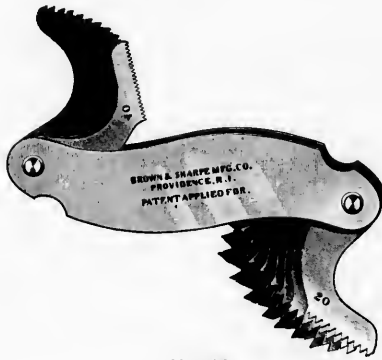

No. 20

Contains pitches 0, 10, 11, 12, 13, 14, 15, 16, 18, 20 on one end, and 22, 24, 26, 28, 30, 32, 34, 36, 38 and 40 on the other end.each \$1.00



No. 22

Pitches 4 to 40
Each \$1.15



FULL SIZE

No. 21

For 16 pitches: 10, 12, 14, 16, 18, 20, 22, 24, 26, 28, 30, 32, 34, 36, 38, 40.each \$1.45

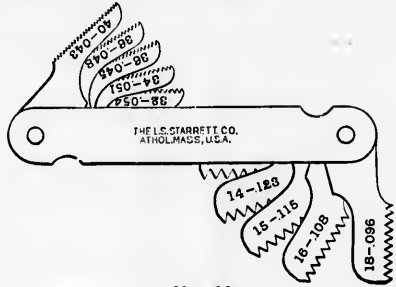

No. 40

This Gauge has 20 pitches, viz.: 9, 10, 11, 12, 13, 14, 15, 16, 18, 20, 22, 24, 26, 28, 30, 32, 34, 36, 38, 40. A late improvement in our Screw Pitch Gauge consists in stamping on each leaf decimals, showing the double depth of thread on said leaf, and this of course, equals the depth of threads on the two sides of a tap having the same pitch, and helps the workman to determine the size of drill needed to drill the hole the right size to leave a full V thread for a tap having the same pitch. each \$1.50

No. 7

For Whitworth Standard Thread only.

20 Pitches, 4 to 30.

Has the following pitches: 4, 5, 6, 7, 8, 9, 10, 11, 12, 13, 14, 16, 18, 20, 22, 24, 25, 26, 28, 30.each \$1.00

No. 11½

For pipe and brass work. This gauge is the same as No. 40, except that pitches 8, 11½ and 27 are substituted in place of 30, 38 and 40.each \$1.50

STARRETT'S SCRATCH GAUGE



No. 29

Made of steel, with hardened cast steel head.

	Graduated.	Not Graduated.
No. 29—5 inch (beam 1½ in.)	each \$1.50	1.00
0 " " 1½ " "	" 1.00	1.15

Two extra cutters will be sent with each gauge, fastened to the case.

GRADUATED CENTRE GAUGE



FULL SIZE

Spring temperedeach	\$0.00
Not tempered " "	0.10

STARRETT'S SPEEDED SCREW MICROMETER

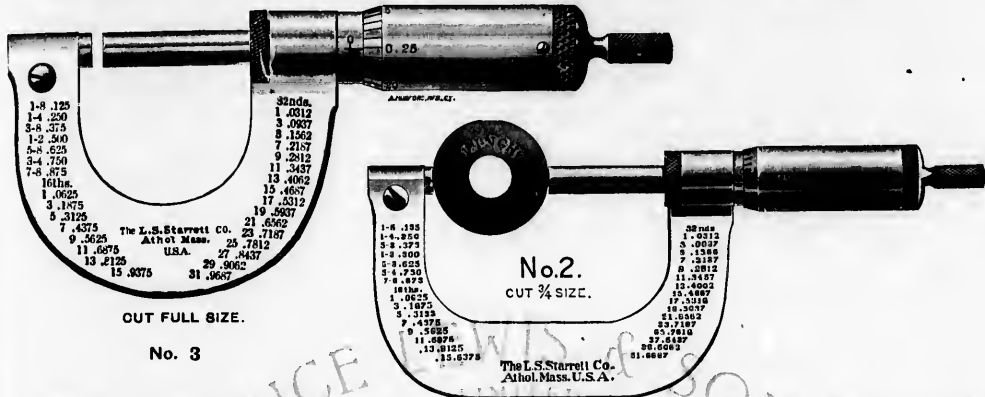

These cuts represent an improved Micrometer with a small knurled thumb piece on the operating end of the spindle, by means of which its rotation is speeded (about three to one) by the action of the thumb and finger between which it is made to rotate.

A further improvement in this Micrometer (saving the necessity of splitting the barrel to take up wear in the nut, with openings for dirt to get through) consists in a bushing running through full length of the barrel, and firmly secured therein, said bushing being chambered in middle inside, and each end tapered outside, both ends being split in three sections nearly half the length. One end is threaded inside for the screw, the other smooth to fit spindle. A knurled nut, threaded on the outside, is screwed to each end of the barrel, telescoping the ends of bushing, one to take up wear and cause a close fit between the screw and nut, the other to contract the bushing to a close fit on the spindle, or by a slight turn of the nut lock firm, thus making a solid gauge when desired, which for reliability has no equal.

- No. 2 is the same as No. 3, except that it is for measurements from 1 inch to 2 inches.
- | | | | |
|--------------------------|-------------|--------------------------|-------------|
| No. 3..... | each \$0.00 | No. 2..... | each \$0.75 |
| In Leatherette case..... | " 0.75 | In Leatherette case..... | " 10.50 |

BROWN & SHARPE MFG. CO.'S MICROMETER

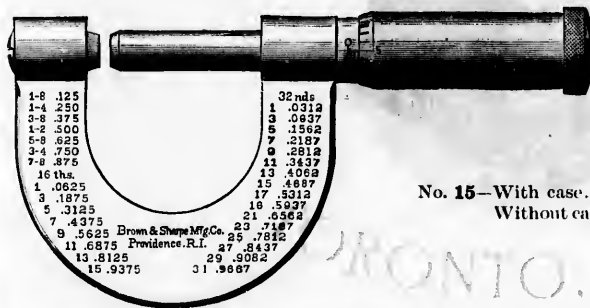

This Caliper is shown full size in cut, and measures all sizes less than an inch by thousandths of an inch.

- | | |
|-----------------------|-------------|
| No. 15—With case..... | each \$8.05 |
| Without case..... | " 7.50 |

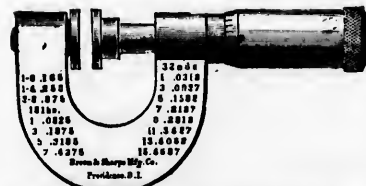
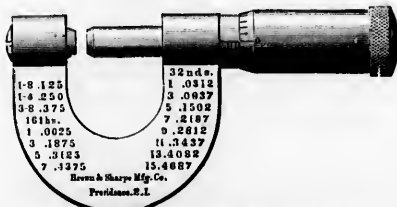

B. & S. MICROMETER, No. 2

B. & S. PAPER GAUGE MICROMETER, No. 70

This Caliper is shown full size in cut, and measures all sizes less than one-half inch by thousandths of an inch.

No. 2—With case.....	each \$7.50
Without case.....	" 6.75

This Caliper is shown full size in cut, and measures all sizes less than 1/2 of an inch by thousandths of an inch.

No. 70—With case.....	each \$0.00
Without case.....	" \$8.25

These Calipers can be supplied in the Metric Measure to order.

LOCK SLIDE CALIPER RULE

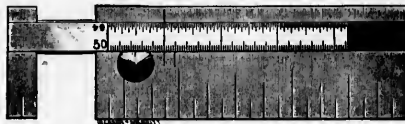

3 inch each \$3.00
 4 " " 3.75

INSIDE CALIPER RULE



3 inch each \$3.75
 4 " " 4.50

The slides in these rules are graduated in 50ths and 64ths and verniers to 100ths, are quickly and accurately adjusted, and when adjusted can be firmly locked in position by a thumb nut.

CALIPER GAUGE

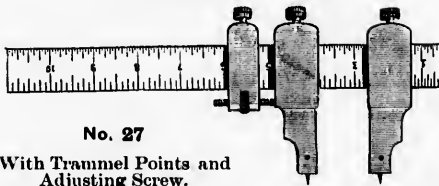

No. 27

With Trammel Points and
 Adjusting Screw.

12 inch each \$6.00

CALIPER GAUGE

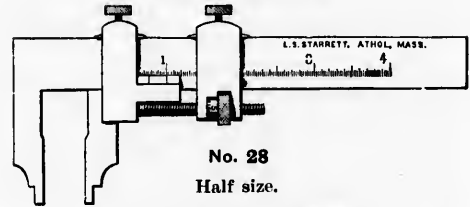

No. 28

Half size.

For Outside and Inside Measure.

Each \$12.00

STARRETT'S DEPTH GAUGE

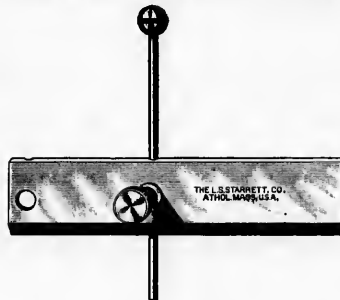

No. 45—With 4 inch stock each \$1.15
 " 6 " " " 1.75
 " 10 " " " 2.00

The wire in this Gauge is held to a groove by a friction spring inside the nut while adjusting, and may be used close to the end, as well as in the middle of the Straight Edge. By loosening the nut, the Gauge may be neatly folded.

STARRETT'S DEPTH GAUGE



No. 46—With 4 inch stock each \$1.00
 " 6 " " " 2.25
 " 6 inch stock, and 6 inch blade .. " 2.05
 " 10 " " 6 " " " 3.40

Has in place of the round wire to slide in the groove, as shown with No. 45, a 4 inch scale, $\frac{1}{8}$ inch wide, graduated in either 32nds and 64ths, 50ths and 100ths, or 64ths and 100ths, indicating exact measurements, and may be used separately from the Gauge.

No. 85
 STEVENS
 DEPTH
 GAUGE



No. 85—Depth Gauge each \$0.75

STARRETT'S ADJUSTABLE CALIPER GAUGE NO. 125

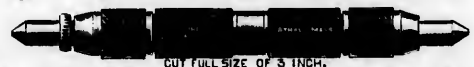

BUY FULL SIZE OF 3 INCH.

3 inch, with two rods, capacity from 3 to 6 $\frac{3}{4}$ in., each \$1.50
 6 " " three " " " 6 " 16 " " 1.00

STARRETT'S COMBINATION SQUARE

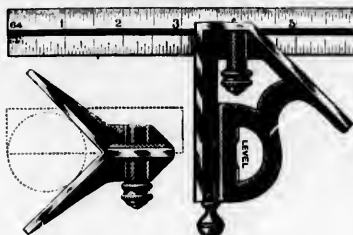

No. 11

With the adjustable scale this forms a most convenient and useful tool. One is a complete substitute for a whole set of common try squares, and is one of the best gauges made for transferring exact measurements or laying out work. It is also convenient for a depth gauge, or to square in a mortise. For a mitre it is perfect, while with the auxiliary centre head it forms a centering square, both inside and outside.

4 inch, without centre head or level.....	\$0.05
6 " with centre head	\$1.00, without 1.25
9 " " " "	2.20 " 1.55
12 " " " "	2.50 " 1.90
18 " " " "	3.45 " 2.80
24 " " " "	4.05 " 3.45

STARRETT'S COMBINATION SET

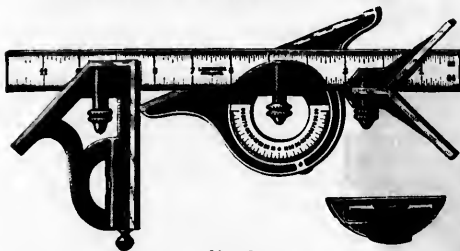

No. 9

This cut shows Combination Square (No. 11), with centre head and 7-inch Bevel Protractor head (No. 12), all on the No. 11 Square scale. Each head may be instantly removed, or replaced and used interchangeably with the scale, thus forming the most useful combination set of tools ever devised for mechanics' use.

9 inch, set complete.....	\$4.70
12 " " "	5.00
18 " " "	5.05
24 " " "	6.55

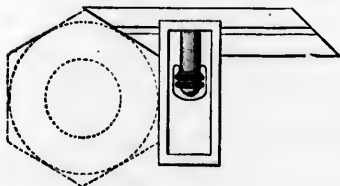

STARRETT'S PATENT DOUBLE SQUARE

This cut represents the 4-inch Double Square stock with hexagon end of blade applied. Reverse it and the octagon is in position for use. Bevel blades are made to fit all sizes of Double Squares.

4 inch	each \$1.00
4 " with bevel blades.....	" 2.45
6 "	" 3.00
6 " with bevel blades.....	" 3.75

Both blades always sent unless otherwise ordered.

CHAPLIN'S TRY AND CENTRE SQUARE

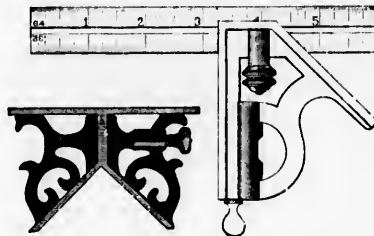

No. 16

A complete set comprises a mitre head, centre head and blade—one blade fitting both heads, with either head forms a complete tool in itself. The several parts will be furnished separately when desired.

	Blade.	Mitre Head.	Centre Head	Complete.
6 inch ..	\$0.05	0.60	0.85	2.00
9 " ..	0.80	0.80	1.20	2.50
12 " ..	1.00	1.00	1.50	3.00

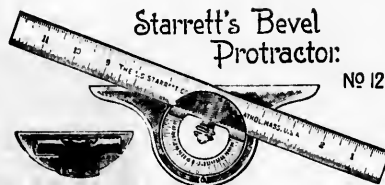

Starrett's Bevel Protractor: No. 12

An adjustable rule, held firmly at any point by a thumb nut, passes through a revolving turret which is nicely graduated in degrees from 0 to 90, both right and left, and can be accurately adjusted to show any angle.

A valuable auxiliary is made in the shape of a small level to be attached in place of the rule removed, forming an adjustable level to show any degree, thus greatly increasing the usefulness of the instrument.

9 inch.....	\$3.45
12 "	3.75
18 "	4.40
24 "	5.00

Protractor Head only, \$2.50.

The blades are the same as those used on No. 11 squares. Those of No. 4 graduation will be sent unless otherwise ordered. The head is 7 inches long.

STARRETT'S PATENT INCLINOMETER



No. 10

It consists of a stock and disc, both slotted to receive the blade. The blade attached to the graduated rotary disc may be secured at any angle from 0 to 90 degrees.

The working face of the stock extending both sides of the blade, admits of its being reversed, so that the same angle may be laid off in opposite directions *without changing* the angle in the tool, thus requiring but one-quarter of a graduated circle to obtain all angles both ways.

No. 10—With 12 in. blade.....	\$ 7.50
" 18 in. "	9.00
" 24 in. "	10.50
Centre head, to fit all sizes.....	1.15

UNIVERSAL BEVEL PROTRACTOR

STARRETT'S

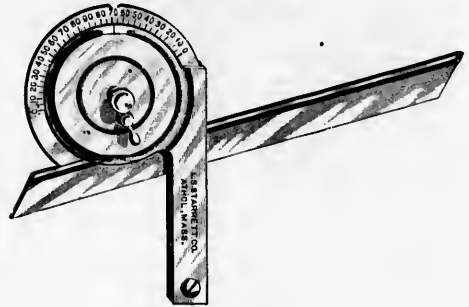

No. 360

The disc is graduated in degree from 0 to 90 each way, and rotates the entire circle on a central stud inside the case. One side of the stock being flat, makes it a convenient tool for laying on paper in drafting, etc.

No. 360—7 inch	\$7.50
12 "	9.00
With both 7 and 12 inch blades.....	9.75

COMBINATION SQUARE AND PROTRACTOR

BELLOWS'

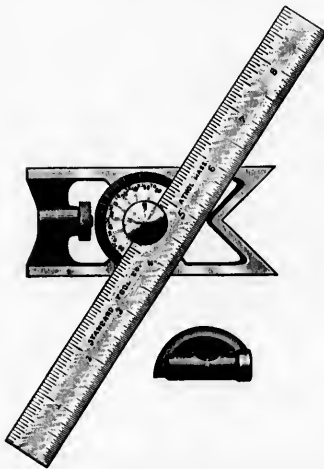

In one end of the frame a slot is milled at an angle of ninety degrees; the blade is grooved its entire length, and is used in this slot when it is desired to use the tool as a square, being drawn to its seat by a hook bolt.

In the centre of the tool a disc graduated in degrees is inserted, having one-half of its surface cut away to allow the blade to be set in so that its surface will be level with the surface of the disc, the blade being held firmly in position by a bolt passing through the disc, and a cam catching in the groove of the blade and forcing it against the side of the disc, where it has been cut away, and in this position it is used as a protractor, or swung to zero and used as a centre square.

A level goes with the tool that can be inserted in the disc in place of the blade when desirable.

Price, 12 inch..... each \$7.50

IMPROVED BEVEL

UNIVERSAL BEVEL

UNIVERSAL BEVEL

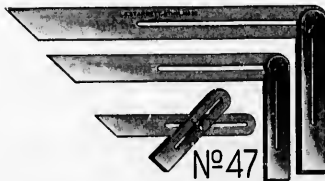

No. 47

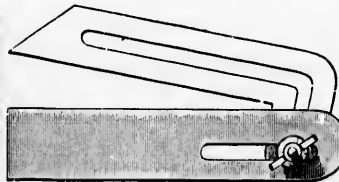

No. 15

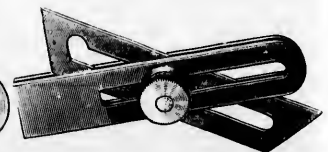

No. 20

No. 47—6 inch.....	each \$1.90
9 "	2.25
12 "	2.65

No. 15—3 inch.....	each \$2.25
--------------------	-------------

No. 20—3 inch.....	each \$1.90
5 "	3.00

TRACTOR



0 to 80 each
le on a cen-
side of the
venient tool
etc.
..... \$7.50
..... 9.00
es..... 0.75

TRACTOR

ty degrees ;
l in this slot
ng drawn to

is inserted,
the blade to
the surface
sition by a
hing in the
e of the disc,
it is used as
ntre square.
e in place of

..... each \$7.50

AL BEVEL

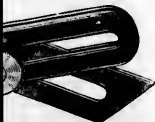

20
..... each \$1.90
..... " 3.00

GRADUATED STEEL SQUARE

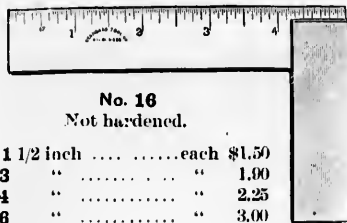

No. 16
Not hardened.

1 1/2 incheach	\$1.50
3	"	1.00
4	"	2.25
6	"	3.00
8	"	4.50
10	"	7.50
12	"	9.75

HARDENED STEEL SQUARE

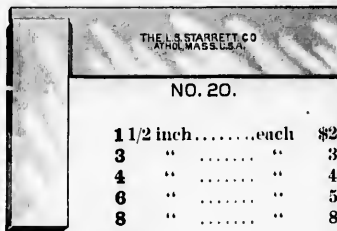

NO. 20.

1 1/2 incheach	\$2.25
3	"	3.40
4	"	4.50
6	"	5.65
8	"	8.65
10	"	10.50
12	"	13.50

IMPROVED IRON FRAME TRY SQUARE

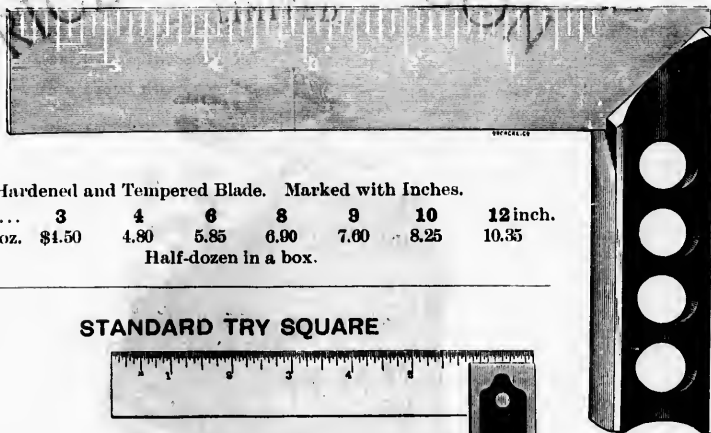

Hardened and Tempered Blade. Marked with Inches.

Size.....	3	4	6	8	9	10	12 inch.
No. 3, Plain Stockper doz.	\$1.50	4.80	5.85	6.90	7.00	8.25 10.35

Half-dozen in a box.

STANDARD TRY SQUARE

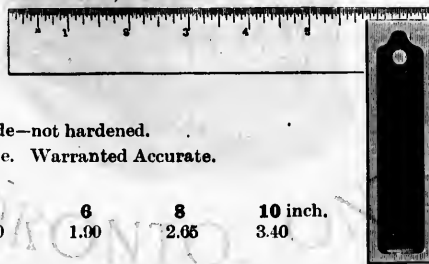

Graduated Steel Blade—not hardened.
Recessed Iron Handle. Warranted Accurate.

Size.....	3	4	6	8	10 inch.
Price.....each	\$1.15	1.50	1.90	2.65	3.40.

UNIVERSAL OR CENTRE SQUARES

The Universal or Centre Squares have blades graduated on one side. The 4 inch blade is graduated to 20ths on one corner and to 32nds of an inch on the other corner. The 6, 8, 10 and 12 inch blades are graduated to 12ths and 48ths on one corner and to 16ths and 32nds of an inch on the other corner.

Length of Blade.....	4	6	8	10	12 inch.
Length of Head.....	3	4	5 1/2	7	8 1/2 "
Each.....	\$3 00	3.75	5.25	7.50	9.00

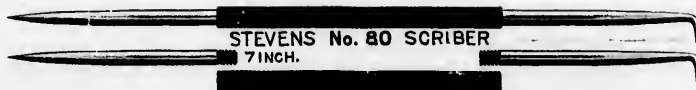
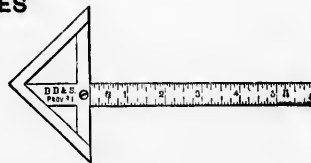

STEVENS No. 80 SCRIBER
7 INCH.

No. 80—Scribers.....each \$0.60

STEEL AND IRON SQUARES

POLISHED STEEL SQUARES

TWO FEET

No. 100	—2 inches wide. Graduated $\frac{1}{8}$, $\frac{1}{16}$, $\frac{1}{32}$, $\frac{1}{64}$, $\frac{1}{8}$, $\frac{1}{4}$, with brace measure, 8 square, $\frac{1}{16}$ scale and Essex's New Board Measure, giving the feet and inches in full.....	per dozen	\$40.00
"	1—2 inches wide. Graduated $\frac{1}{8}$, $\frac{1}{16}$, $\frac{1}{32}$, $\frac{1}{64}$, with board and brace measure, 8 square and $\frac{1}{16}$ scale.....	per dozen	30.00
"	2—2 inches wide. Graduated $\frac{1}{8}$, $\frac{1}{16}$, $\frac{1}{32}$, $\frac{1}{64}$, with board and brace measure and 8 square scale.....	per dozen	27.00
"	3—2 inches wide. Graduated $\frac{1}{8}$, $\frac{1}{16}$, $\frac{1}{32}$, $\frac{1}{64}$, with board and brace measure.....	"	24.00
"	5—2 " " " $\frac{1}{8}$, $\frac{1}{16}$, $\frac{1}{32}$, with board and brace measure.....	"	22.50
"	7—2 " " " $\frac{1}{8}$, $\frac{1}{16}$, 1 inch, with board measure.....	"	21.50
"	14—2 " " " $\frac{1}{8}$, $\frac{1}{16}$, 1 inch, with board measure.....	"	21.00

NICKEL-PLATED STEEL SQUARES

TWO FEET

No. 102	—2 inches wide. Graduated $\frac{1}{8}$, $\frac{1}{16}$, $\frac{1}{32}$, $\frac{1}{64}$, with board and brace measure and 8 square scale.....	per dozen	35.00
---------	---	-----------	-------

POLISHED STEEL SQUARES

ONE FOOT

No. 11	—1½ inch wide. Graduated $\frac{1}{8}$ and $\frac{1}{16}$ inch.....	per dozen	17.00
" 12	—1½ " " " $\frac{1}{8}$, $\frac{1}{16}$ and $\frac{1}{32}$ inch.....	"	22.00

BRIGHT IRON SQUARES

TWO FEET

No. 492	—1½ inch wide. Graduated $\frac{1}{8}$ ths on one side.....	per dozen	2.15
" 493	—1½ " " " $\frac{1}{8}$ ths on both sides.....	"	2.85
" 494	—2 inches wide. " $\frac{1}{8}$ ths ".....	"	3.80
" 494½	—2 " " " $\frac{1}{8}$ ths on one side.....	"	2.85

Steel, quarter dozen in a box. Iron, half dozen in a package.

THIN STEEL SQUARES FOR MACHINISTS

2	inch Blade, Graduated 16ths and 64ths, 32nds and 64ths.....	each	1.50
3	" " " " " " " ".....	"	2.25
4	" " " " both sides, 16ths and 32nds.....	"	3.00
6	" " " " " " " ".....	"	4.50

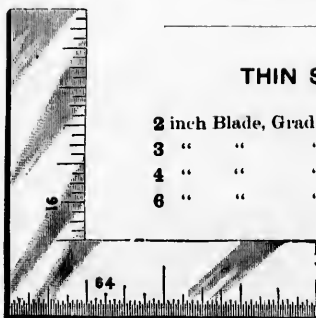

TRY SQUARES

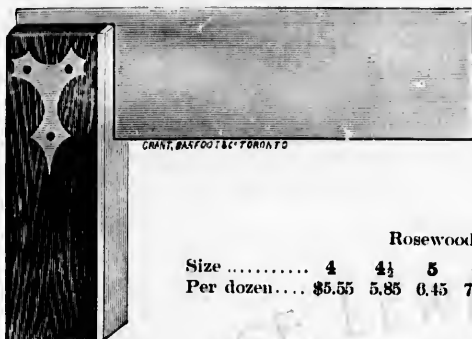

MARPLES' No. 550

Rosewood Handle, Brass Plate, Steel Blade.

Size	4	4½	5	6	7	8	9	10	12	14	16	18	inch.
Per dozen....	\$5.55	5.85	6.45	7.10	8.25	9.50	10.00	11.70	13.20	16.20	20.35	22.15	

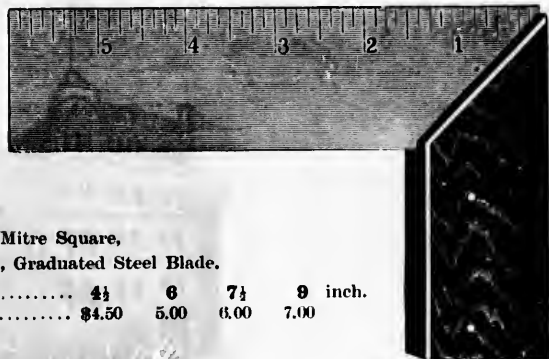

No. 2

Combined Try and Mitre Square,

Rosewood Handle, Brass Plate, Graduated Steel Blade.

Size	4½	6	7½	9	inch.
Per dozen....	\$4.50	5.00	6.00	7.00	

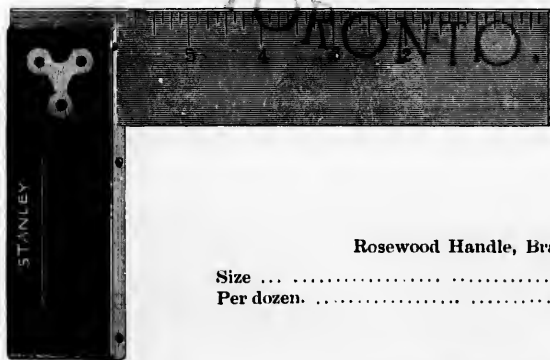

No. 20

Rosewood Handle, Brass Plate, Graduated Steel Blade.

Size	4½	6	7½	9	10	12	inch.
Per dozen....	\$3.75	5.00	5.75	6.50	7.25	8.50	

Packed half-dozen in a box.

ADJUSTABLE TRY SQUARES

Iron Handles, Graduated Steel Blade.

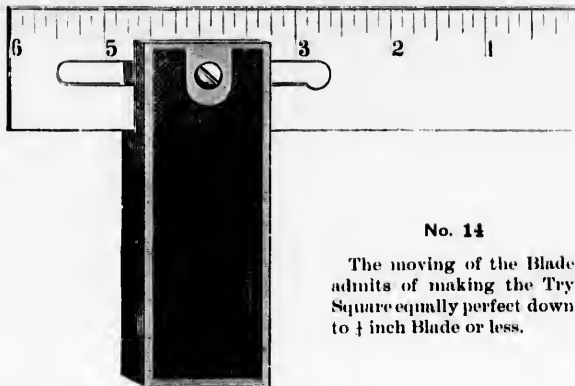

No. 14

The moving of the Blade admits of making the Try Square equally perfect down to $\frac{1}{4}$ inch Blade or less.

No. 14—4 inch, one-half dozen in a box per doz. \$3.75
 6 " " " " " " 4.55

SLIDING T BEVELS

Rosewood Handle.
 Brass Tips and Flush Lever.
 Hardened and Tempered Blade.

No. 25—6 inch per doz. \$5.50
 8 " " 6.00
 10 " " 6.50
 12 " " 7.00

Half-dozen in a box.

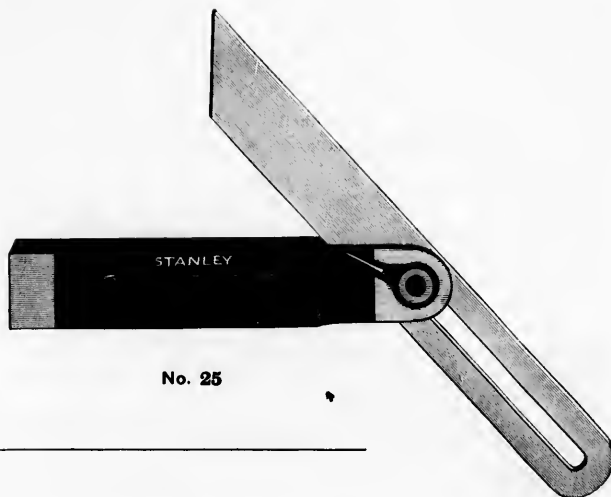

No. 25

SHIP CARPENTERS' BEVELS



No. 42—Boxwood, Double Tongue, 8ths and 16ths..... per doz. \$6.00

POCKET LEVELS

 No. 11—2½ inches long, Nickel-Plated.....each \$0.00
 " 12—3½ " " " " 0.75

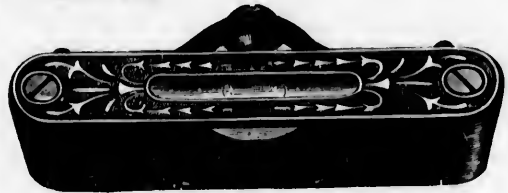

 No. 1 P—2½ inches long.....each \$0.40
 " 2 P—3½ " " " " 0.15



No. 41

No. 40—Iron Top Plate, Japannedper dozen \$1.30
 " 41—Buss " " " " 1.50
 One dozen in a box.

 No. 3—4 inch Iron Level.....each \$1.00



 No. 4—6 inch Iron Level.....each \$1.15



 No. 39—6 inch Iron Level, Nickel-Plated Top Plate.....each \$0.50

PLUMBS AND LEVELS



 No. 5
 Nos. 5
 Length..... 6
 Each \$2.25

WITH DOUBLE PLUMB

 No. 6
 Nos. 6
 Length..... 9
 Each 2.50

 Nos. 7
 Length..... 12
 Each 2.65

 Nos. 8
 Length..... 18
 Each 3.00

 Nos. 9
 Length..... 24 inch.
 Each 3.40



Nos. 14 to 16
Adjustable. The Tubes are Nickel-Plated; Bases are Japanned.

Nos. 14
 Length..... 4
 Each \$1.00

Nos. 15
 Length..... 6
 Each 2.40

Nos. 16
 Length..... 8 inch.
 Each 2.85

 ADJUSTABLE
 Nos. 06
 Length..... 6
 Each \$2.00

Nos. 07
 Length..... 12
 Each 3.25

Nos. 08
 Length..... 18
 Each 3.00

Nos. 09
 Length..... 24 inch.
 Each 4.35

SPIRIT LEVEL, PLUMB, AND INCLINOMETER

DAVIS' PATENT ADJUSTABLE

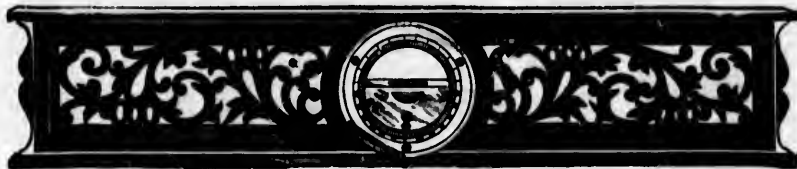

Nos.....	1	2	3	4	
Length.....	7	12	18	24	inch
Each.....	\$3.00	4.50	5.40	6.30	

LEVELLING AND SQUARING INSTRUMENT

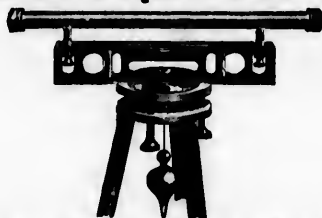

It is adapted for the use of Architects, Carpenters, Builders, Stone-masons and others, for levelling, getting angles, etc. It is made of iron, japanned. The sight tube is of brass, nickel-plated; weight packed in a box ready for shipment, 13 3/4 lbs.each, complete \$18.75

GROOVED LEVEL



Above is shown a new Level, grooved on the bottom the whole length, which anyone who has occasion to level up shafting, piping, etc., will see the advantage of, as it enables the user to place the level in line with the shaft or pipe as readily as on a flat surface. These Levels are so made that they can be used on a flat surface the same as ordinary levels.

No. 105—6 inch.....	each	\$2.25
" 107—12 ".....	"	2.65

IMPROVED LEVEL SIGHTS



No. 1—Pair in a box.....per pair \$0.95

BIT AND SQUARE LEVEL

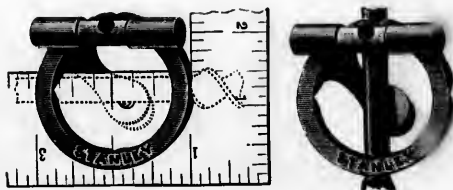

No. 44—Bit and Square Level, Brass Frame, in a box.....each \$0.35

PLUMBS AND LEVELS



No. 0.

No. 00	Plumb and Level, Arch Top Plate, Two Side Views, Polished, assorted, 18 to 24 inch	per doz.	\$16.00
" 0	" " " " " " " " " " " " " " 24 to 30	" " "	18.00
" 102	Levels " " " " " " " " " " " " " 10 to 18	" " "	9.00
" 103	" " " " " " " " " " " " " 18 to 24	" " "	12.00
" 104	Plumb and Level, " " " " " " " " " " " " " 12 to 18	" " "	14.00

PATENT IMPROVED ADJUSTABLE PLUMBS AND LEVELS



No. 3

No. 2	Patent Adjustable Plumb and Level, Arch Top Plate, Two Brass Lipped Side Views, Polished, assorted, 24 to 30 inch	per doz.	27.00
" 3	Patent Adjustable Plumb and Level, Arch Top Plate, Two Side Views, Polished and Tipped, assorted, 24 to 30 inch	per doz.	30.00



No. 5

No. 5	Patent Adjustable Plumb and Level, Triple Stock, Arch Top Plate, Two Ornamental Brass Lipped Side Views, Polished and Tipped, assorted, 24 to 30 inch	per doz.	48.00
" 6	Patent Adjustable Mahogany Plumb and Level, Arch Top Plate, Two Brass Lipped Side Views, Polished, assorted, 24 to 30 inch	per doz.	33.00
" 10	Patent Adjustable Mahogany Plumb and Level, Triple Stock, Two Ornamental Brass Lipped Side Views, Arch Top Plate, Polished and Tipped, assorted, 24 to 30 inch	per doz.	60.00



No. 25

No. 25	Patent Adjustable Plumb and Level, Mahogany, Arch Top Plate, Improved Duplex Side Views, Polished, Tipped, assorted, 24 to 30 inch	per doz.	67.10
" 30	Patent Adjustable Plumb and Level, Cherry, Arch Top Plate, Improved Duplex Side Views, Polished, Tipped, assorted, 24 to 30 inch	per doz.	51.85

Packed half-dozen in a box.

4
24 inch
6.90

etting
ked in
plete \$18.75

sion to level
the shaft or
the same as

each \$2.25
2.65

each \$0.35

PLUMBS AND LEVELS

RABONE'S



No. 1370

No. 1368—12 inch Boxwood Level and Rule, Brass Ends.....	per doz.	\$ 6.30
" 1370—12 " " Plumb, Level and Rule, Brass Ends.....	"	12.25
18 " " " " " " " " " " " " " " " " " "	"	16.75
24 " " " " " " " " " " " " " " " " " "	"	20.75

Half-dozen in a box.

MASONS' PLUMB AND LEVEL



PROVED LEVEL GLASSES



Made of Extra Thick Tubing.

Length.....	1 3/4	2	2 1/2	3	3 1/2	4	4 1/2 inch.
Per gross....	\$0.50	10.00	10.50	11.50	13.00	14.50	16.00

Assorted, 1 3/4, 3, 3 1/2 inch.....per gross \$12.00

One, dozen in a box.

STANLEY'S "ODD JOBS"



ODD JOBS

This tool embraces in itself and when in combination with an ordinary Carpenter Rule; a Mitre Level, Spirit Level and Plumb; Try, Mitre and T Square; Marking and Mortise Gauge, Beam Compass, Inside Square for making boxes and frames.

No. 1—Odd Jobs, Nickel-Plated with Level.....each \$0.30

One in a box.

MASONS' PLUMB AND LEVEL

No. 35—Patent, Adjustable, Masons' Plumb and Level, adapted also for Plumb Bob and Line. Length 42 inches.....	per doz.	40.00
--	----------	-------

PLUMB BOBS



No. 2



No. 00

No. 2—Iron, Japanned, Adjusted Top, weight 9 $\frac{1}{2}$ oz.	per doz.	\$1.00
" 00— " " " " " 1 lb. 2 oz.	"	1.00

No. 2, one dozen; No. 00, half-dozen in a box.



No. 4



Nos. 13 and 15

No. 4—Lead, Steel Pointed, weight 1 $\frac{1}{2}$ lbs.	per doz.	\$6.00
" 13— " Masons', Wired " 1 "	"	4.75
" 15— " " " 2 "	"	8.00

Nos. 4 and 13, half-dozen; No. 15, quarter-dozen in a box.

BRASS PLUMB BOBS

CAST BRASS, STEEL POINTED, SCREW TOP.



No. 5—Weight 6 oz.	per doz.	\$5.25
" 6— " 11 $\frac{1}{2}$ "	"	4.80

Half-dozen in a box.

STANLEY'S ADJUSTABLE PLUMB BOBS

Nos. 5 and 6

No. 2—Weight 11 $\frac{1}{2}$ oz., Steel Pointed, complete with Line and Reel	each	\$1.75
--	------	--------



Half-size Cut of
Stanley's No. 2

MASONS'
PLUMB
AND LEVEL



N. 33

STEEL RULES

BROWN AND SHARPE MANUFACTURING CO'S

STANDARD STEEL RULES



Size.....	3	6	9	12	18	24	inch.
Each.....	\$0.55	1.00	1.50	1.90	3.00	4.15	

GRADUATION

No. 2-8; 10, 20, 50, 100; 12, 24, 48; 16, 32, 64.
No. 4-8, 16, 32, 64.

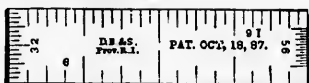

WITH END GRADUATIONS

Size.....	3	4	6	9	12	inch.
Each.....	\$0.55	0.70	1.00	1.50	1.90	

In these Rules the ends are graduated on one side to 48ths and 100ths, and on the other side, as shown in cut, to 32nds and 58ths of an inch. The 32nds extend entirely across the rule.
The 3 in. Rules are graduated to 40ths instead of 100ths on the end. These Rules are furnished with No. 4 graduation only.

RULES WITH METRIC MEASURE

Size.....	5 C.M.	10 C.M.
Each.....	\$0.40	0.70

First corners graduated to 1.5 m.m., the remaining corners to 1 m.m.

Size.....	20 C.M.	30 C.M.
Each.....	\$1.30	1.90

Five centimetres of first corner graduated to 1.5 m.m., the remainder of that corner together with the remaining corners graduated to 1 m.m.

Size.....	50 C.M.	1 Metre.
Each.....	\$3.00	12.00

Five centimetres on each end of first corner graduated to 1.5 m.m., the remainder of that corner together with the remaining corners graduated to 1 m.m.

Rules with combined Metric and English measure same price as Metric.

STANDARD STEEL RULES

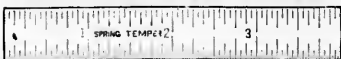

Size.....	1	3	6	9	12	18	24	inch.
Each.....	\$0.25	0.55	1.00	1.50	1.90	3.00	3.75	

Graduated 8ths, 16ths, 32nds and 64ths. Other graduations to order.

WITH END GRADUATIONS

Size.....	3	6	9	12	inch.
Each.....	\$0.55	1.00	1.50	1.90	

RULES WITH METRIC MEASURE

5 C.M.....	1.9685	inch.	each	\$0.40
10 ".....	3.9370	"	"	0.75
15 ".....	5.9055	"	"	1.15
20 ".....	7.8740	"	"	1.50
25 ".....	9.8425	"	"	1.90
30 ".....	11.8110	"	"	2.25
40 ".....	15.7480	"	"	3.00
50 ".....	19.6850	"	"	3.75
60 ".....	23.6220	"	"	6.50

RULES WITH COMBINED METRIC AND ENGLISH MEASURE

Same dimensions and prices as Metric Rules.

Rules graduated in the Metric System, or combining both the Metric and English measures, are not kept in stock. They can be supplied on short notice.

TEMPERED STEEL RULES

Every Rule is marked "Tempered."

These Rules are about 1/20 inch thick

Size.....	4	6	9	12	18	inch.
Width.....	$\frac{3}{8}$	$\frac{1}{2}$	$\frac{3}{4}$	$\frac{1}{2}$	1	"
Each.....	\$0.70	1.00	1.50	1.90	3.00	

Graduations—Nos. 2 or 4.

NARROW TEMPERED STEEL RULES

Every Rule is marked "Tempered."

These Rules are about 1/20 inch thick, and about 7/32 inch wide, and graduated on one corner of each side only.

Size.....	4	6	inch.
Each.....	\$0.70	1.00	

Graduated in 32nds and 64ths, 64ths and 100ths, or 50ths and 100ths.

FLEXIBLE STEEL RULES

Every Rule is marked "Tempered."

Graduated on one side only.

Size.....	4	6	9	12	18	24	inch.
Each.....	\$0.70	1.00	1.50	1.90	3.00	4.15	

Graduated in 32nds and 64ths, 64ths and 100ths, or 50ths and 100ths

SPRING TEMPERED STEEL RULES

Length.....	3	4	6	9	12	18	24	inch.
Width.....	$\frac{3}{8}$	$\frac{1}{2}$	$\frac{3}{4}$	$\frac{1}{2}$	$\frac{1}{2}$	$\frac{1}{2}$	$\frac{1}{2}$	"
Each.....	\$0.55	0.70	1.00	1.50	1.90	3.00	3.75	

Thickness— $\frac{3}{16}$ inch, or No. 18 gauge.

NARROW STEEL RULES

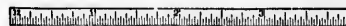

Size.....	4	6	9	12	inch.
Each.....	\$0.70	1.00	1.50	1.90	

3/16 inch wide, No. 18 gauge, spring-tempered, graduated one corner each side whole length, either in 32nds and 64ths, 50ths and 100ths, or 64ths and 100ths.

FLEXIBLE STEEL RULES



Size.....	4	6	9	12	18	24	inch.
Each.....	\$0.70	1.00	1.50	1.90	3.00	3.75	

Graduated on one side only, in other 32nds and 64ths, 64ths and 100ths, or 50ths and 100ths. 4, 6, 9 and 12 inch are $\frac{1}{2}$ inch wide; 18 and 24 inch are $\frac{1}{4}$ inch wide.

STEEL RULES

SQUARE STEEL RULES

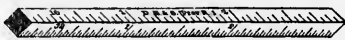

Size.....	3	4	6	Inch.
Each	\$0.70	0.90	1.35	
Graduated 8ths, 10ths, 32nds and 64ths.				

TRIANGULAR STEEL RULES



Size.....	3	4	6	Inch.
Each	\$0.75	1.05	1.50	
Graduated 10ths, 64ths and 100ths.				

KEY SEAT RULES



Parallel lines for key seats, mortises, etc., can be readily and accurately drawn with these rules on shafts not less than 1/4 inch in diameter.

The edges are bevelled. One edge is graduated into 16ths, and the other into 32nds of an inch.

Size	4	6	8	Inch.
Each	\$3.75	4.50	5.05	

FOLDING RULES

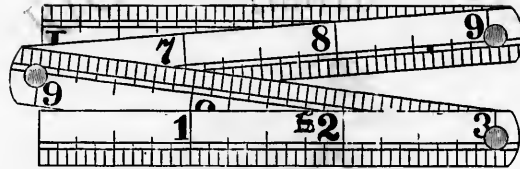

No. 31. ONE FOOT. FULL SIZE.

They are made of spring steel and will bend to a 3-inch circle.

No.	Length	Width	Material	Graduation	Price	Price with cases
No. 31	1 foot	3/8 inch	26 gauge	3 inch joints, 4 fold, graduated 16ths on both sides	per doz. \$4.00	\$5.50
" 31-2	"	"	"	"	8.00	10.00
" 41-1	"	"	"	"	4.00	5.50
" 41-2	"	"	"	"	7.50	9.50
" 41-3	"	"	"	"	11.00	13.50

SPRING JOINT STEEL RULES

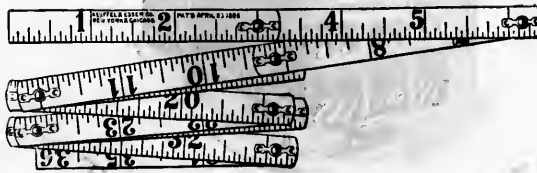

No. 27

These rules are made of carefully tempered spring steel, 1/8 inch wide and graduated on both sides in inches and sixteenths. They consist of alternate longer and shorter links, so that the rivets at the joint do not come on top of each other in the folded rule. This improvement admits of using much stouter rivets than ordinarily and still making a thinner folded rule than any other kind. The aligning springs at the joints hold the rule in a rigid straight line when it is opened, without in any way interfering with folding it.

No. 25	Steel Pocket Rule, 1 foot, 4 fold	per doz.	\$5.00
" 26	" " " 2 " 8 "	"	10.00
" 27	" " " 3 " 12 "	"	15.00
Sheathes for above.....			1.00

FOLDING BOXWOOD RULES

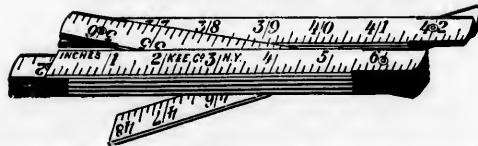

These rules are provided with spring joints, so that vertical or horizontal distances may be measured.

No. 28	2 feet, 4 fold, graduated 1/8, 1/4, 1/2 inch to the foot	per doz.	\$4.40
" 29	3 " 6 " " 1/8, 1/4, 1/2 " " " "	"	6.15
" 30	4 " 8 " " 1/8, 1/4, 1/2 " " " "	"	8.40

CHESTERMAN'S STEEL RULES



GRADUATED ON ONE SIDE

Size		3	4	6	12 inch.
No. 300D	per doz.	\$3.20	3.20	3.00	6.00
" 310D				4.80	7.20

GRADUATED BOTH SIDES

Size		4	6	12 inch.
No. 326D	per doz.	\$4.80	5.00	8.00
" 332D			7.20	10.40

GRADUATIONS

No. **300D**, Top Edge, inches into 16ths; Bottom Edge, 3 inches into 32nds; $\frac{1}{2}$ inch into 64ths; remainder into 8ths. No. **310D**, Top Edge, 3 inches into 20ths; 1 inch into 50ths; 1 inch into 100ths; remainder into 10ths.

No. **326D**, Top Edge, 3 inches into 24ths; 1 inch into 48ths; remainder into 12ths. Bottom Edge, 3 inches into 32nds; $\frac{1}{2}$ inch into 64ths; remainder into 8ths. Lower Side Top Edge, 3 inches into 20ths; 1 inch into 50ths; remainder into 10ths. Lower Side Bottom Edge, inches into 16ths. No. **332D**, Top Edge, inches into 8ths; Bottom Edge, inches into 16ths; Lower Side Top Edge, inches into 32nds; Lower Side Bottom Edge, inches into 64ths.

CHESTERMAN'S STEEL STRAIGHT EDGES

No. 48 —12 x $1\frac{1}{2}$ inch, 15G, not graduated, bright hardened steel, with one edge bevelled and hole at one end...	Per doz.
24 x $1\frac{1}{2}$ " 15G, " " " " " " " " " "	\$10.50 22.80

BLACKSMITH RULES



No. 1660

No. 1651 —Marples' 2 feet, 2 fold, Brass, Button Joint, $\frac{1}{4}$ inch wide	per doz. \$4.45
" 1654 — " " " " Acorn " $1\frac{1}{2}$ "	" 8.85
" 1660 — " " " " Iron " $1\frac{1}{2}$ "	" 3.00



No. 1661

No. 1661 —Marples' 2 feet, 2 fold, Elastic Steel, Brass-Tipped Ends, Etched Markings, $\frac{3}{4}$ inch wide	per doz. \$6.05
" 58 —Chesterman's " " " " One-stop Joint Brass Ends " " " "	" 5.00
" 240 — " " " " " " Plain Ends, Etched Markings, " " " "	" 4.75
" 66 — " " 1 foot, Steel, Etched Markings both sides, $\frac{3}{4}$ inch wide, 21 Gauge.....	" 2.00
" 60 —Lufkin's 1 " " " " $\frac{1}{2}$ and $\frac{3}{8}$ ths, $\frac{1}{2}$ " " 21 "	" 4.00
" 60 — " 2 " " " " " $\frac{1}{2}$ and $\frac{3}{8}$ ths, $\frac{1}{2}$ " " 21 "	" 8.00
" 62 — " 1 " " " " " $\frac{1}{2}$ and $\frac{3}{8}$ ths, $1\frac{1}{2}$ " " 16 "	" 8.00
" 62 — " 2 " " " " " $\frac{1}{2}$ and $\frac{3}{8}$ ths, $1\frac{1}{2}$ " " 16 "	" 15.00
" 62 — " 3 " " " " " $\frac{1}{2}$ and $\frac{3}{8}$ ths, $1\frac{1}{2}$ " " 16 "	" 22.00

COMPARATIVE NUMBERS OF RULES

BOXWOOD RULES

Stanley's.	Chapin's.	Stephen's.	Standard.	List.
Nos.	Nos.	Nos.	Nos.	Per Doz.
1	41	1	\$ 7 00
2	42	13	2	8 00
4	44	15	4	10 00
5	45	17	5	16 00
6	50	16	6	18 00
8	8	4 50
12	48	14	12	14 00
13	10 00
15	49	27	15	24 00
16	51	28	16	28 00
18	39	2	18	5 00
22	40	5	22	8 00
26	46	9	26	9 00
27	47	27	12 00
29	38	1	27	3 50
32	72	98	32	12 00
32½	73	99	32½	20 00
36	70	95	36	7 00
36½	70½	36½	12 00
42	85	31	42	6 00
43	85½	30	43	6 00
51	16	46	51	6 00
52	18	49¼	52	13 00
53	17	48	53	8 00
53½	17½	39	53½	20 00
54	19	49	54	16 00
55	6	73	55	4 00
56	7	74	56	6 00
57	9	75	57	12 00
58	96	33	58	13 00
58½	58½	3 60
59	20	50	59	9 00
60	21	52	60	21 00
61	11	42	61	5 00
61½	11½	44	61½	5 50
62	15	42½	62	15 00
62½	15½	42¾	62½	15 00
63	12	45	63	7 00
63½	13	44½	63½	8 00
64	3	72	64	5 00
65	2	71	65	3 50
65½	5	72½	65½	11 00
66	84	66	8 00
66½	32	8 00
67	22	53	67	5 00
68	10	41	68	4 00
69	1	70	69	3 00
70	23	54	70	7 00
72	24	56	72	9 00
72½	6	54½	72½	18 00
73	27	57	73	9 00

BOXWOOD RULES

Stanley's.	Chapin's.	Stephen's.	Standard.	List.
Nos.	Nos.	Nos.	Nos.	Per Doz.
75	28	59	75	11 00
76	30	60	76	20 00
77	31	61	77	12 00
78	78	20 00
78½	32	63	78½	24 00
79	34	64	79	11 00
81	36	66	81	13 00
82	37	67	82	22 00
83	33	83	14 00
84	14	42¼	84	12 00
94	48 00

IVORY RULES

38	74	95½	38	15 00
39	76	98½	39	38 00
40	77	99½	40	44 00
85	59	77	85	54 00
86	60	83	86	64 00
86½	96 00
87	61	84	87	80 00
88	57	94	88	32 00
88½	56	93	88½	21 00
89	62	86	89	92 00
90	52	89	90	10 00
91	58	91½	91	23 00
92	55	91	92	17 00
92½	54	90½	92½	14 00
95	64	87	95	102 00
97	67	88	97	116 00

MISCELLANEOUS RULES

33	82	32	2 00
34	80	34	3 00
35	81	35	6 00
41	83	41	3 50
43½	90½	43½	12 00
44	92	44	5 00
45	93	45	7 00
45½	94½	45½	18 00
46	87O	46	8 00
46½	87S	46½	8 00
47	88G	47	12 00
47½	88S	47½	12 00
48	89	48	12 00
48½	89½	48½	15 00

12 inch.
6.00
7.20

12 inch.
8.00
10.40

remainder into
into 10ths.

age, 3 inches into
50ths; remainder
s; Bottom Edge,
64ths.

Per doz.
one end...\$10.50
" " " 22.80

per doz. \$4.45
" " 8.85
" " 3.00

per doz. \$6.95
" " 5.90
" " 4.75
" " 2.00
" " 4.00
" " 8.00
" " 8.00
" " 15.00
" " 22.00

BOXWOOD RULES

CALIPER RULES



No. 36

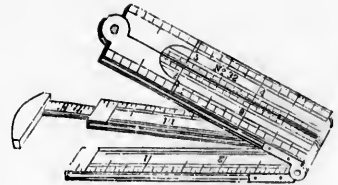

No. 32

No. 13	- Six Inch, Square Joint, Two Fold, 8ths and 16ths, $1\frac{1}{4}$ inch wide	per doz.	\$10.00
" 13 1/2	- "	"	12.00
" 36	- "	"	7.00
" 32	- One Foot, Arch Joint, Edge Plate, Four Fold, 8ths, 10ths, 12ths and 16ths, 1 inch wide..	"	12.00
" 32 1/2	- "	"	20.00

ONE FOOT, FOUR FOLD, NARROW



No. 69

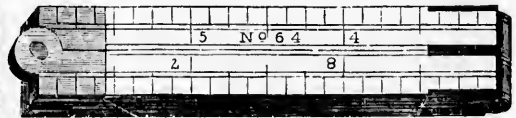

No. 64

No. 69	- Round Joint, Middle Plates, 8ths and 16ths, $\frac{5}{8}$ inch wide	per doz.	\$3.00
" 65	- Square "	"	3.50
" 64	- " " " Edge "	"	5.00
" 56	- Arch "	"	6.00

TWO FEET, TWO FOLD

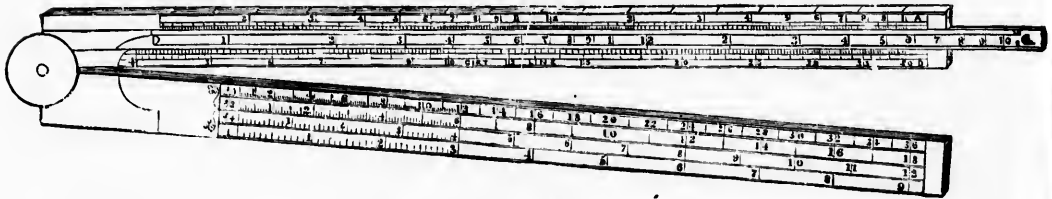

No. 12

No. 26	- Square Joint, Slide, 8ths, 10ths and 16ths, Octagonal Scales, $1\frac{1}{4}$ inch wide	per doz.	\$ 9.00
" 2	- Arch " " Bitted "	"	8.00
" 4	- " " " " (Plates on outside of wood), Bitted, extra thin, 8ths and 16ths, Drafting and Octagonal Scales, $1\frac{1}{4}$ inch wide.	"	10.00
" 18	- Square Joint, 8ths and 16ths, $1\frac{1}{4}$ inch wide	"	5 00
" 12	- Arch " " Bitted, Gunther's Slide, 8ths, 10ths, 16ths and 100ths of a foot, Drafting and Octagonal Scales, $1\frac{1}{4}$ inch wide.	"	14.00

TWO FEET, SIX FOLD

No. 58	- Arch Joint, Edge Plates, 8ths, 10ths, 12ths and 16ths, $\frac{3}{4}$ inch wide.	per doz.	\$13.00
--------	---	----------	---------

BOXWOOD RULES

TWO FEET, FOUR FOLD, NARROW

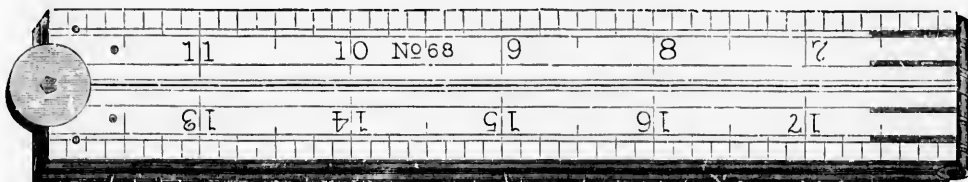

No. 68

- No. 68—Round Joint, Middle Plates, 8ths and 16ths, 1 inch wide..... per doz. \$4.00
 " 61—Square " " " 8ths " 16ths, 1 " " " " " " 5.00
 " 51—Arch " " " 8ths, 10ths, 12ths and 16ths, Drafting Scales, 1 inch wide " " " " 6.00

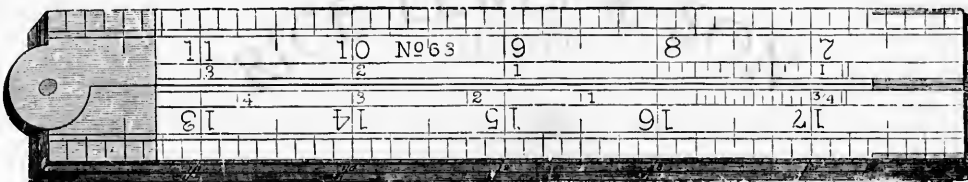

No. 63

- No. 63—Square Joint, Edge Plates, 8ths, 10ths, 12ths and 16ths, Drafting Scales, 1 inch wide per doz. \$7.00
 " 53—Arch " " " 8ths, 10ths, 12ths " 16ths, " " 1 " " " " " " 8.00
 " 59—Double Arch Joint, Bitted, 8ths, 10ths, 12ths " 16ths, " " 1 " " " " " " 9.00

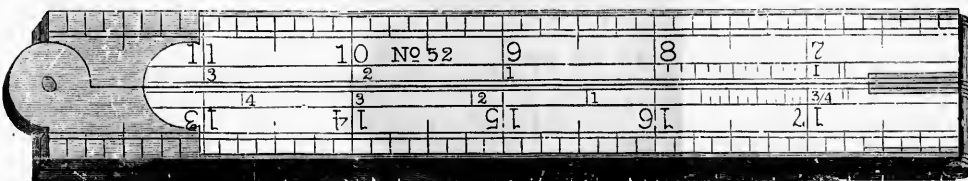

No. 52

- No. 52—Arch Joint, Half Bound, 8ths, 10ths, 12ths and 16ths, Drafting Scales, 1 inch wide..... per doz. \$13.00
 " 84—Square " " " 8ths, 10ths, 12ths " 16ths, " " 1 " " " " " " 12.00
 " 62— " " " 8ths, 10ths, 12ths " 16ths, " " 1 " " " " " " 15.00
 " 54—Arch " " " 8ths, 10ths, 12ths " 16ths, " " 1 " " " " " " 16.00
 " 60—Double Arch Joint " 8ths, 10ths, 12ths " 16ths, " " 1 " " " " " " 21.00

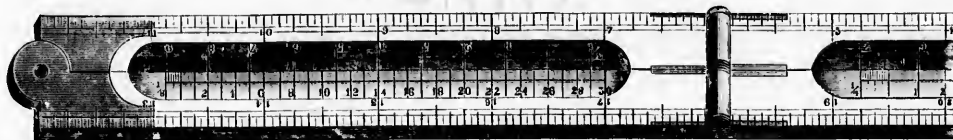

No. 53 1/2

- No. 53 1/2—Arch Joint, Edge Plates, 8ths, 10ths, 12ths and 16ths, with inside Bevelled Edge, and Architects' Drafting Scales, 1 inch wide..... per doz. \$15.00

RABONE BOXWOOD RULES

TWO FEET, FOUR FOLD

- No. 1106—Arch Joint, Bevel Edge..... per doz. 28.00
 " 1118— " " " (with Edge Plates)..... " " 34.25

BOXWOOD RULES

TWO FEET, FOUR FOLD, BROAD

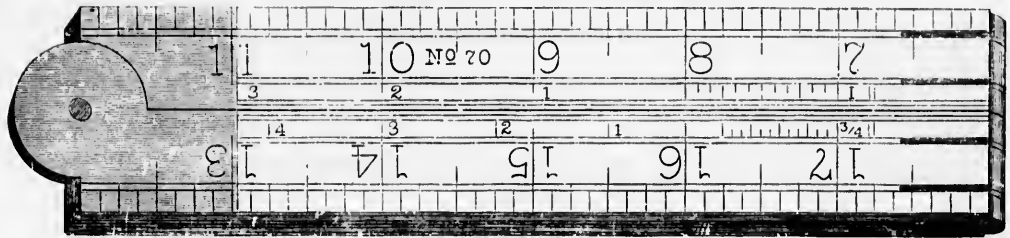

No. 70

- No. 70—Square Joint, Middle Plates, 8ths and 16ths, Drafting Scales, 1 1/2 inch wide.....per doz. \$ 7.00
 " 72— " " Edge " 8ths " 16ths, " " " " " 9.00
 " 72 1/2— " " Bound.....8ths " 16ths, " " " " " 18.00

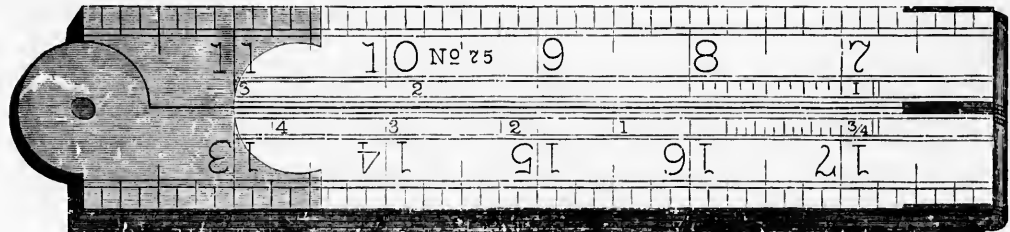

No. 75

- No. 73—Arch Joint, Middle Plates, 8ths, 10ths and 16ths, Drafting Scales, 1 1/2 inch wide.....per doz. \$ 9.00
 " 75— " " Edge " 8ths, 10ths " 16ths, " " " " " 11.00
 " 81— " " " " 12ths and 16ths " " " " " 13.00
 " 76— " " Bound8ths, 10ths and 16ths " " " " " 20.00

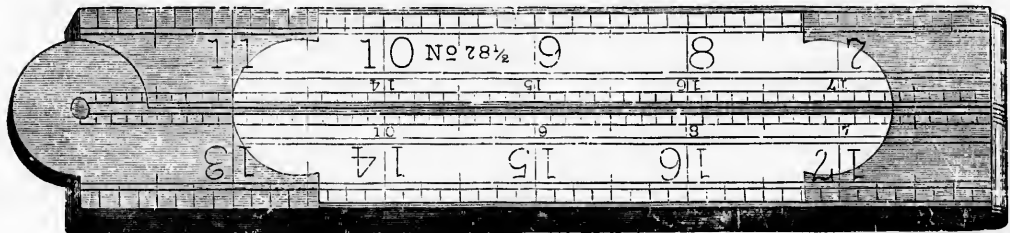

No. 78 1/2

- No. 77—Double Arch Joint, Bitted, 8ths, 10ths and 16ths, Drafting Scales, 1 1/2 inch wide.....per doz. \$12.00
 " 78 1/2— " " " Bound, 8ths, 10ths " 16ths, " " " " " 24.00
 Half-dozen in a box.

THREE FEET, FOUR FOLD

- No. 66 1/2—Arch Joint, Middle Plates, 8ths and 16ths, 1 inch wideper doz. 8.00

PATTERNMAKERS' SHRINKAGE RULES

- No. 30—Boxwood, 8ths and 16ths, 24 1/2 inches long.....per doz. 15.00
 " 31— " Two Fold, Triple-plated Edge Plates, 8ths and 16ths, 24 1/2 inches long..... " 18.00

IVORY RULES



No. 38, with Caliper.

TWO FEET, FOUR FOLD

- | | | | |
|--------|---|----------|---------|
| No. 85 | Square Joint, German Silver, Edge Plates, 8ths, 10ths, 12ths and 16ths, $\frac{1}{4}$ inch wide | per doz. | \$54.00 |
| No. 86 | Arch " " " " " " " " " " " " 8ths, 10ths, 12ths " " " " " " 16ths, 100ths foot, Drafting Scales,
1 inch wide | per doz. | 64.00 |

ONE FOOT, FOUR FOLD

- | | | | |
|----------------------|---|----------|-------|
| No. 39 | Square Joint, German Silver, Edge Plates, 8ths, 10ths, 12ths and 16ths, $\frac{1}{4}$ inch wide | per doz. | 38.00 |
| No. 88 | Arch " " " " " " " " " " " " " " " " " " 8ths and 16ths | " " | 32.00 |
| No. 88 $\frac{1}{2}$ | " " " " " " " " " " " " " " " " " " 8ths " 16ths | " " | 21.00 |
| No. 90 | Round " " Brass Middle " 8ths " 10ths | " " | 10.00 |

SIX INCH, TWO FOLD

- | | | | |
|--------|--|----------|-------|
| No. 38 | Square Joint, German Silver, Edge Plates, with Calliper, $\frac{1}{4}$ inch wide | per doz. | 15.00 |
|--------|--|----------|-------|

IMPROVED DESK RULERS



- | | | | |
|-------|--|----------|--------|
| No. 1 | Maple Colored Grooves, 12 inches long, $1\frac{1}{2}$ inch wide | per doz. | \$1.05 |
| No. 2 | " " " " " " " " " " " " " " " " " " 18 " 1 $\frac{1}{2}$ " | " " | 2.50 |
| No. 3 | Boxwood, Grooves not colored, 12 inches long, $1\frac{1}{2}$ inch wide | " " | 6.00 |

COUNTER YARD MEASURES



Nos. 1 and 2

- | | | | |
|--------|---|----------|--------|
| No. 1 | Brass | per doz. | \$4.00 |
| No. 2 | Nickel-Plated | " " | 4.50 |
| No. 72 | Brass, for screwing to Counter, marked inches in 8ths | " " | 7.00 |
| No. 33 | Yard Stick, Polished | " " | 1.50 |
| No. 41 | " " Brass Tips, Polished | " " | 2.50 |
| No. 50 | " " Hickory, Brass-capped Ends, Polished | " " | 3.20 |

Government Inspection, for Wood Measures, net	each	\$0.05
" " " " Brass	" "	0.08

GAUGING RODS

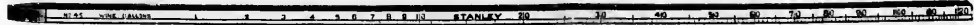

- | | | | |
|-------|--|------|--------|
| No. 1 | 48 inch Rod, with Wine Measure on one side, Imperial Standard on the other side, and inches on the two remaining sides | each | \$2.25 |
| No. 2 | 48 inch Rod, with Imperial Standard on one side, inches on two sides, and the fourth side blank | " " | 2.15 |

DIRECTIONS—To ascertain the capacity of a barrel, insert the Rod in the bung hole in a slanting direction to the chime. Note point on the rod which comes exactly in the middle of the bung hole on a line with the under side of the stave, then reverse the process at the other end. If the bung hole is exactly in the middle of the barrel, the capacity will be shown. If the measurements differ, add them together and divide by two, and you have the number of gallons the barrel will hold.

WANTAGE RODS



- | | | | |
|--------|---|----------|--------|
| No. 44 | 8 tables, or lines, for Barrels 16, 23, 32, 42, 48, 84, 110 and 120 gallons | per doz. | \$3.75 |
|--------|---|----------|--------|

DIRECTIONS—Having capacity of the barrel, insert the Wantage Rod perpendicularly in the bung hole, holding it so that the brass lip points towards the head of the barrel; lower until lip comes just under the inner side of stave. The mark where the rod is wet on the line which has the full capacity of the barrel at the top, shows the number of gallons that are wanting to fill it up.

HICKORY BOARD RULES

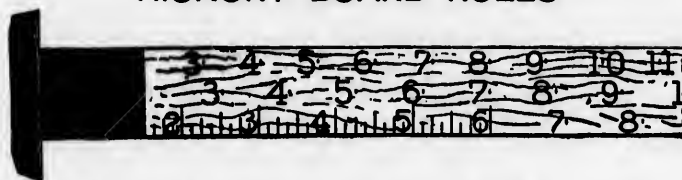

No. 1-3 Tier,	Brass Head, Handled, 3 foot long, marked 9, 10, 11 and 12, 14, 16.....	per doz.	\$11.00
" 3-3 "	Square Steel Head, " 3 " " " " 9, 10, 13 and 12, 14, 16.....	"	18.85
" 3-3 "	" " " " " 3 " " " 12, 14, 16 and 18, 20, 22.....	"	21.75
" 4-4 "	" " " " " 3 " " " 9, 10, 11, 13 and 12, 14, 16, 81.....	"	20.30
" 5-4 "	" " " " " 3 " " " 13, 11, 10, 12, and 14, 15, 16, 9.....	"	17.40
" 17-5 "	" " " " " 3 " " " 7, 8, 9, 10, 11 and 12, 13, 14, 15, 16.....	"	20.00



ACME HANDLE

No. 20-3 Tier,	Square Steel Head, Acme Handle, marked 9, 10, 13 and 12, 14, 16.....	per doz.	20.30
" 21-3 "	Diamond " " " " " 8, 10, 18 and 12, 14, 16.....	"	20.30
" 22-4 "	Square " " " " " 8, 9, 10, 11 and 12, 14, 16, 18.....	"	21.75
" 23-4 "	Diamond " " " " " 8, 9, 10, 11 and 12, 14, 16, 18.....	"	23.20
" 24-5 "	Square " " " " " 7, 8, 9, 10, 11 and 12, 13, 14, 15, 16.....	"	20.10
" 25-5 "	Diamond " " " " " 7, 8, 9, 10, 11 and 12, 13, 14, 15, 16.....	"	23.20

LUFKIN HICKORY BOARD RULES

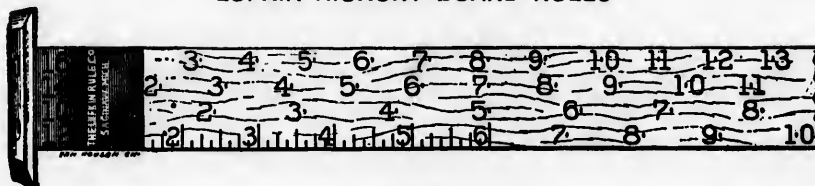

No. 8

No. 2-3 Tier,	3 foot, Extra Heavy, Brazed Square Head, marked 8, 10, 18 and 12, 14, 16.....	per doz.	25.00
" 7-4 "	" 3 " Patent Socket, Square Steel " 8, 10, 20, 22 and 12, 14, 16, 18.....	"	23.00
" 8-4 "	" 3 " Brazed, Square Steel Head, " 0, 11, 13, 15 and 12, 10, 14, 16.....	"	25.00
" 10-5 "	" 3 " Patent Socket, Square Steel Head " 7, 8, 9, 10, 11 and 12, 13, 14, 15, 16..	"	30.00

SPRING STEEL BOARD RULES



No. 52-3 Tier,	3 foot, marked same as Hickory Rule No. 2.....	per doz.	40.50
" 58-4 "	" 3 " " " " " " 7.....	"	43.00
" 59-5 "	" 3 " " " " " " 10.....	"	47.25

These Rules are Nickel-plated and Lacquered, and provided with Wood Handle and Leather Slide.

LOG RULES



No. 48½

No. 48½-Octagon	Walking Cane, 3 foot, Doyle, Cast Brass Head and Tip.....	per doz.	\$11.00
" 2-	" measures to 36 in. Diameter, Doyle or Scribner.....	"	11.00
" 1-Flat,	3 lines, each side measures to 44 in. Diameter, Doyle or Scribner, or combined.....	"	18.00
" 2-	" 3 " " " " 36 " " " ".....	"	12.00

LUMBER GAUGES

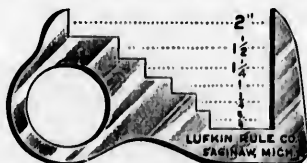

Nickel-plated for Vest Pocket.

No. 00—Measures $\frac{3}{4}$ to 2 inches per doz. \$4.75

STEEL TIMBER GAUGES



30 inches long each \$2.50

BENTON TALLY REGISTERS

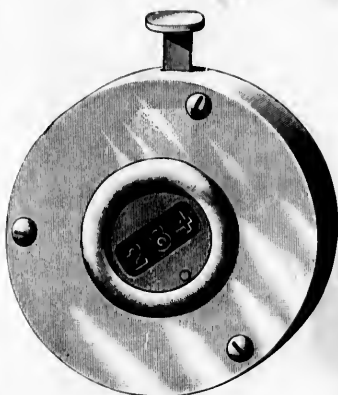

Full Size.

The Register in use is held in position as shown in the cut. The middle finger of the left hand is passed through the ring on the back to prevent accidental dropping from the hand and to better hold it in position so as to bring the pusher directly under the thumb.

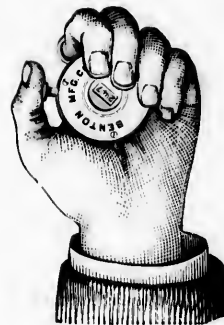

No. 0—Nickel-plated. per doz. \$45.00

TIMBER SCRIBES

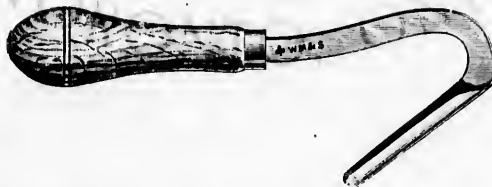

No. 1894—Ottawa Pattern, Swan Neck per doz. \$6.75



No. 1895—To work a circle..... per doz. 0.25

" 8866—Pocket Timber Scribe, 3 inch Stag Handle containing one $2\frac{1}{2}$ inch Folding Scriber and one $2\frac{1}{2}$ inch Knife Blade per doz. 11.35

per doz. \$11.00
 " 18.85
 " 21.75
 " 20.30
 " 17.40
 " 20.00

per doz. 20.30
 " 20.30
 " 21.75
 " 23.20
 " 20.10
 " 23.20

43
 -10

per doz. 25.00
 " 23.00
 " 25.00
 " 30.00

per doz. 40.50
 " 43.00
 " 47.25
 per Slide.

per doz. \$11.00
 " 11.00
 " 18.00
 " 12.00

MEASURING TAPES

CHESTERMAN'S PATENT

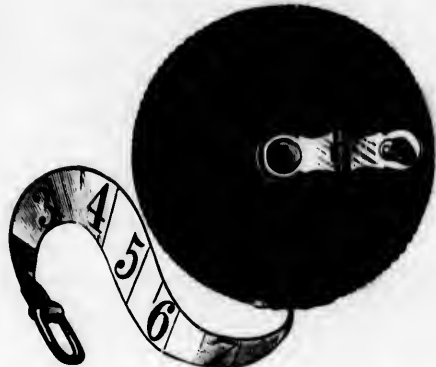

IN LEATHER CASES

WITH PATENT METALLIC TAPES

Tapes 1/2 inch wide, marked feet and inches on one side, links and poles on the other.

Length.....	33	50	66	100 feet.
No. 1820 —With Brass Folding Handles.....	each \$1.80	2.15	2.55	3.00
" 1820 —Marked in feet and 10ths.....	"	2.15	...	3.00
" 1821 —With Brass Flush Handles.....	2.05	2.45	2.00	4.00
" 1860 —Tapes only without Cases.....	1.30	1.00

WITH LINEN TAPES

Tapes 1/2 inch wide, marked feet and inches on one side, links and poles on the other.

Length.....	33	50	66	100 feet.
No. 1822 —With Brass Folding Handles.....	each \$1.10	1.35	1.00	2.15
" 1861 —Tapes only without Case.....	"	0.70	0.85

LEATHER CASED TAPE LINES

Tapes 1/2 inch wide, marked feet and inches.

Length.....	33	66	100 feet.
No. 1063 —Black, Brass Lined, Folding Handles.....	per doz. \$4.10	5.70
" C1132 —White " " " " " " " " " " " " " "	3.95
" 1992 —Russet, all Leather Cases, Folding Handles.....	"	10.85	14.50
" 3702 —Black " " " " " " " " " " " " " "	7.75

TIMBER GIRTHING TAPES

No. 119 —Without Case, Best Linen Tapes, 1/2 inch wide, girth both sides.....	per doz. \$6.00
--	-----------------

TAILORS' TAPES

No. 3 —Linen, 60 inches long, 1/4 inch wide, 1/4ths on one side.....	per gross \$6.00
---	------------------

CHESTERMAN'S POCKET STEEL TAPES



Brass Cases, Spring Wind, with Stop.

Length.....	3	6	9	12	18 feet.
No. 1810	per doz. \$11.20	16.80	23.25	27.25	38.40

MEASURING TAPES



CHESTERMAN'S STEEL TAPE LINES

In leather cases, with brass Flush Handles, Tapes $\frac{3}{8}$ inch wide, marked feet, inches and $\frac{1}{16}$ ths on one side, and links and poles on the other.

Length.....	33	50	66	100 feet
No. 1840	each \$1.10	5.85	0.95	0.70

CHESTERMAN'S STEEL TAPE LINES FOR SURVEYORS



In enamelled metal cases, with folding handles.

No. 157 —Steel Tape $\frac{1}{2}$ inch wide, marked feet and $\frac{1}{16}$ ths, on one side only	each \$0.40
“ 158 “ “ $\frac{3}{8}$ “ “ “ “ $\frac{1}{16}$ ths, “ “	“ 0.00

LUFKIN'S STEEL TAPE LINES

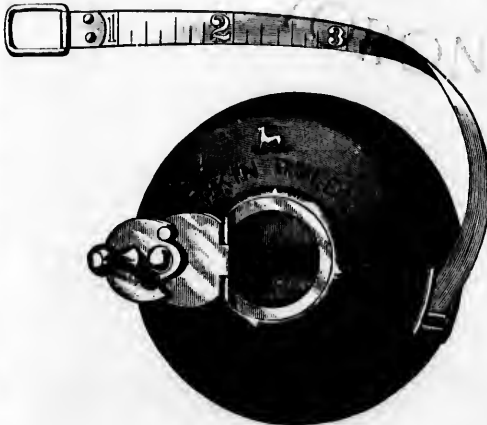

IN LEATHER CASES

Double Folding Flush Handle, $\frac{3}{8}$ inch Tapes, marked feet, inches and $\frac{1}{16}$ ths on one side, links and poles on other.

Nos.....	200	201	203	204	
Length.....	25	33	40	60	feet
Each.....	\$5.65	0.50	9.00	11.50	

IN NICKEL-PLATED BRASS CASES

Flush Handles, $\frac{3}{8}$ Tapes, marked feet, inches and $\frac{1}{16}$ ths, one side.

Nos.....	240	245	246	
Length.....	25	75	100	feet
Each.....	\$1.10	6.00	8.45	

ROE'S STEEL MEASURING TAPES

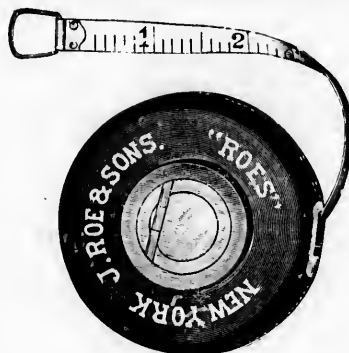

Nos. 101 to 115

TAPES 1/2 INCH WIDE

Leather Cases, Flush Handles, Nickel-Plated Trimmings.

Length	33	50	66	100 feet.	
No. 101—Feet divided in 12ths	each	\$6.00	8.10	10.20	14.00
" 102— " " 10ths, with Links	"	6.60	9.00	11.40	16.20
" 103— " " 12ths, " "	"	6.60	9.00	11.40	16.20
" 104— " " 12ths, " Metre	"	6.60	9.00	11.40	16.20
" 105— " " 10ths, " "	"	6.60	9.00	11.40	16.20

TAPES 3/8 INCH WIDE

Leather Cases, Flush Handles, Nickel-Plated Trimmings.

Length	33	50	66	100 feet.	
No. 111—Feet divided in 12ths	each	\$5.40	7.30	9.20	12.85
" 112— " " 10ths, with Links	"	6.00	8.20	10.40	14.65
" 113— " " 12ths, " "	"	6.00	8.20	10.40	14.65
" 114— " " 12ths, " Metre	"	6.00	8.20	10.40	14.65
" 115— " " 10ths, " "	"	6.00	8.20	10.40	14.65



No. 250

TAPES 3/8 INCH WIDE

Nickel-Plated Brass Cases, marked one side only.

Length	25	50	75	100 feet.	
No. 250—Feet divided in inches and 8ths	each	\$4.45	5.50	7.20	9.30
" 251— " " 10ths " 100ths	"	4.45	5.50	7.20	9.30

TAPES 3/16 INCH WIDE

Japanned Metal Cases, Folding Handle.

Length	33	50	66	100 feet.	
No. 202—Feet divided in 10ths, with Links	each	\$5.40	6.00	6.60	14.10
" 204— " " 10ths, " Metre	"	5.40	6.00	6.60	14.10

ROE'S STEEL TAPES ON METAL FRAME

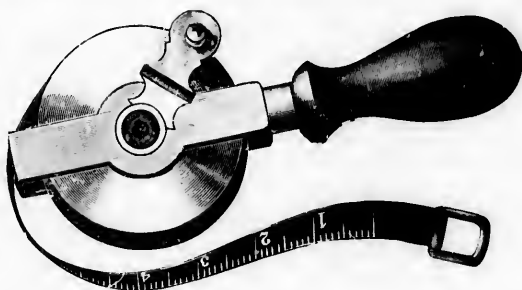

Tapes $\frac{1}{4}$ inch wide, Rings at both ends, not attached to Frame.

Length		50	66	100 feet.
No. 126—Feet divided in 12ths	each	\$6.00	8.70	12.00
" 127— " " 10ths, with Links	"	7.50	9.90	14.40
" 128— " " 12ths, "	"	7.50	9.90	14.40
" 129— " " 10ths, with Metre	"	8.40	12.00	16.80
" 130— " " 12ths, "	"	8.40	12.00	16.80

36
20
40
40
40
40
40
100 feet.
14.00
16.20
16.20
16.20
16.20
16.20

ROE'S STEEL CHAINS

On Patent Electric Reel.

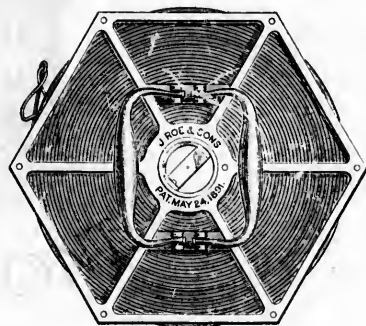
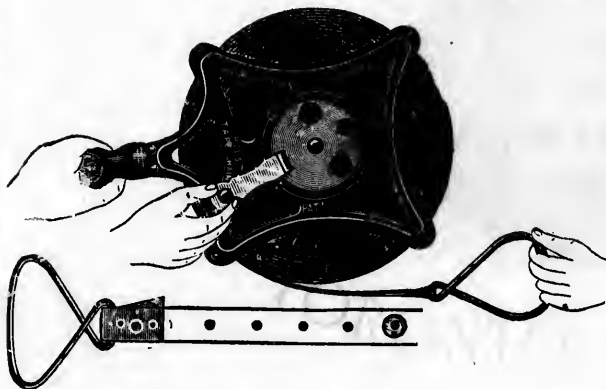

Nos. 1A to 5

Nos. 30 and 31

No.	Length	End feet	each	Plain.	Aluminum Plated.
No. 1A	100 feet	every foot, end feet in 10ths	each	\$6.00	7.20
" 1B	100 "	" " " "	"	6.00	7.20
" 2	100 "	" 5 feet, " 10ths	"	4.80	6.00
" 3	100 "	" 5 " " inches	"	4.80	6.00
" 5	00 "	in rods and 10ths of a rod	"	6.00	7.20
" 11A	200 "	every foot, end feet in 10ths	"	9.00	10.80
" 11B	200 "	" " " inches	"	9.00	10.80
" 30	300 "	" " " 10ths or inches	"	12.00	14.40
" 31	300 "	" 5 feet, " "	"	9.00	12.00

100 feet.
9.30
9.30

100 feet.
14.10
14.10

These Tapes are made of superior steel, about $\frac{1}{4}$ inch wide, graduated every foot or link by brass rivets, and each end foot in 10ths or inches. Every 5 feet or links has a brass clasp with numbers, and every 10 feet or links has a copper clasp with numbers indelibly stamped on both sides. This style of Chain can be supplied in 10, 15, 20, 25, or 50 metres long. Prices on application.

CHESTERMAN'S STEEL BAND MEASURING CHAINS



No. 2120. In Case.

Length	50	66	100 feet.
No. 2109—Divided into Links, and Numbered at every Ten Links, Width of Band $\frac{3}{8}$ inch	\$0.65
“ 2111—Divided into Feet, and Numbered at every Ten Feet, Width of Band $\frac{3}{8}$ inch ..	\$3.55
“ 2112—Divided into Feet, and Numbered at every Ten Feet, Width of Band $\frac{3}{8}$ inch	\$8.15
“ 2113—Divided into Feet, and Numbered at every Ten Feet, Width of Band $\frac{3}{8}$ inch	0.65
“ 2120—Etched Feet and Inches and $\frac{1}{16}$ ths, one side links the other, $\frac{3}{8}$ inch wide ..	7.80	14.00
“ 2120—In Case as shown above	14.50
“ 2120—Etched Feet and ($\frac{1}{16}$) tenths, one side links the other, $\frac{3}{8}$ inch wide	7.80	14.00

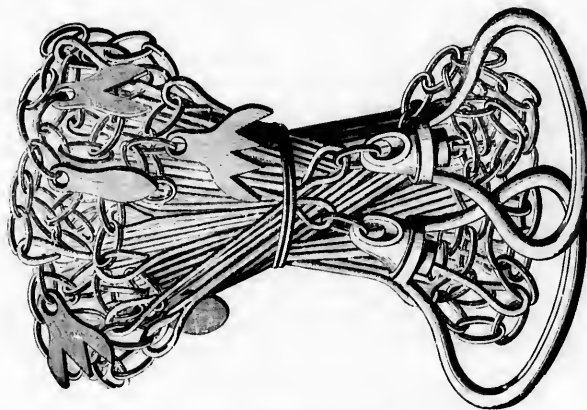

LAND CHAINS

Divided into Links and Talled at every Ten Links.

Length	50	66	100 feet.
No. 61—Best No. 12 Steel Wire, Japanned, Three Oval Links, Brass Swivel Handles, each	\$3.15	\$5.00	\$5.75
“ 62—Best No. 8 Iron Wire, Three Oval Links, Brass Swivel Handles	2.00	3.25
“ 62 $\frac{1}{2}$ —Best No. 8 Iron Wire, Two Oval Links, Brass Swivel Handles	2.00

SURVEYORS' PINS

No. 259—17 inches long, 2-inch Ring, 11 to Set	per set	\$0.75
--	---------	--------

AINS

CAST STEEL TANGED FIRMER CHISELS



Size.....	1/4	3/16	1/4	5/16	3/8	7/16	1/2	5/8	3/4	7/8	1	1 1/4	1 1/2	1 3/4	2	inch.
Length of Blade....	4 1/4	4 1/4	4 3/4	4 3/4	4 3/4	4 3/4	4 3/4	5 1/4	5 1/4	5 3/4	5 3/4	6 1/4	6 1/4	6 3/4	7	"
Per dozen.....	\$1.35	1.35	1.35	1.45	1.50	1.70	1.75	1.95	2.10	2.40	2.55	3.20	3.50	4.35	5.30	0.40
In Sets of 12 Chisels, 1/4 to 1 1/2 inch.....	per set															\$2.25
" 12 " 1/4 to 2 "	" "															3.00

TANGED FIRMER CHISELS

BEVEL BACK



Size.....	3/16	1/4	5/16	3/8	7/16	1/2	5/8	3/4	7/8	1	1 1/4	1 1/2	1 3/4	2	inch.	
Length of Blade.....	4	4 1/4	4 1/4	4 3/4	4 3/4	4 3/4	5 1/4	5 1/4	5 3/4	5 3/4	6 1/4	6 1/4	6 3/4	7 1/4	"	
Per dozen.....	\$2.10	2.10	2.20	2.30	2.45	2.50	2.75	2.90	3.25	3.45	4.20	4.50	5.60	6.00	8.15	
In Sets of 12 Chisels, 1/4 to 1 1/2 inch.....	per set															\$3.15
" 12 " 1/4 to 2 "	" "															4.10

TANGED FIRMER CHISELS, HANDLED

BEVEL BACK



No. 215—In Sets, 1/4 to 2 inch, with Octagon Boxwood Handles	per set															\$5.25
" 215 1/2— " 1/4 to 2 inch, " " " Bevelled Back	" "															6.35

CAST STEEL TANGED PARING CHISELS



Size.....	1/4	3/16	1/4	5/16	3/8	7/16	1/2	5/8	3/4	7/8	1	1 1/4	1 1/2	1 3/4	2	inch.
Length of Blade.....	7 1/2	7 3/4	7 3/4	8	8	8 1/4	8 1/4	8 3/4	8 3/4	9 1/4	9 1/4	9 3/4	9 3/4	10 1/4	10 1/4	11 1/4
Per dozen.....	\$2.10	2.40	2.40	2.50	2.50	2.75	2.75	3.05	3.15	3.70	4.50	5.15	6.10	7.35	8.05	10.75
In Sets of 12 Chisels, 1/4 to 2 inch.....	per set															\$5.15

TANGED PARING CHISELS, HANDLED

No. 222 1/2—In Sets, 1/4 to 2 inch, with Boxwood Handles	per set															\$8.25
--	---------	--	--	--	--	--	--	--	--	--	--	--	--	--	--	--------

TANGED PARING CHISELS

BEVELLED BACK

Size.....	1/4	3/16	1/4	5/16	3/8	7/16	1/2	5/8	3/4	7/8	1	1 1/4	1 1/2	1 3/4	2	inch.
Length of Blade....	8	8	8	8 1/4	8 1/4	8 1/4	8 1/4	8 3/4	8 3/4	9 1/4	9 1/4	9 3/4	9 3/4	10 1/4	10 1/4	11 1/4
Per dozen.....	\$3.30	3.30	3.30	3.40	3.40	3.65	3.65	4.05	4.45	4.65	5.75	6.70	7.35	8.95	10.70	12.95
In Sets of 12 Chisels, 1/4 to 2 inch.....	per set															\$6.50

Chisels priced by the dozen in quarter and half-dozen packages.

66 100 feet.
\$0.05
.....
\$8.15
.....
0.05
.....
14.00
.....
14.00
.....
14.00

66 100 feet.
5.00 \$5.75
2.00 3.25
2.00

per set \$0.75

CHISELS

LONG THIN C. S. PARING CHISELS, HANDLED BEVELLED BACK



No. 212	- In Sets, 1/4 to 2 inch, with Octagon Beech Handles	per set	\$8.00
" 212 1/2	- " 1/4 to 2 " " " Boxwood "	"	9.70
" 213	- " 1/4 to 2 " " " Beech "	"	8.00
" 213 1/2	- " 1/4 to 2 " " " Boxwood "	"	9.70

MILLWRIGHTS' CAST STEEL CHISELS

10-INCH BLADE



Size	1/4	3/16	1/4	5/16	3/8	7/16	1/2	5/8	3/4	7/8	1	1 1/8	1 1/4	1 1/2	1 3/4	2	inch.
Per dozen	\$3.00	4.00	4.00	4.05	4.05	5.15	5.15	5.00	5.00	6.00	7.20	8.00	8.50	10.25	11.75	15.20	
In Sets of 12 Chisels, 1/4 to 2 inch	per set \$7.25																

CAST STEEL TANGED TURNING CHISELS



Size	1/4	3/16	1/4	5/16	3/8	7/16	1/2	5/8	3/4	7/8	1	1 1/8	1 1/4	1 1/2	1 3/4	2	inch.
Length of Blade	6	6	6	6	6	6	6	6	6	6 1/2	6 3/4	6 3/4	6 3/4	6 3/4	7	7	"
Per dozen	\$1.95	2.10	2.10	2.35	2.35	2.60	2.90	3.20	3.70	4.15	4.15	4.65	5.95	7.20	8.50		
In Sets of 12 Chisels, 1/4 to 2 inch	per set \$4.35																

CAST STEEL TANGED FIRMER GOUGES



Size	1/8	3/16	1/4	5/16	3/8	7/16	1/2	5/8	3/4	7/8	1	1 1/8	1 1/4	1 1/2	1 3/4	2	inch.	
Length of Blade	4 1/2	4 1/2	4 1/2	4 1/2	4 1/2	4 1/2	4 1/2	4 1/2	4 1/2	4 1/2	4 1/2	4 1/2	4 1/2	4 1/2	4 1/2	4 1/2	5 1/2	"
Per dozen	\$1.70	1.70	1.70	1.70	1.75	1.85	2.00	2.10	2.25	2.55	2.90	3.05	3.85	4.35	5.30	8.00		
Size	3/4	7/8	1	1 1/4	1 1/4	1 1/2	1 3/4	2	inch.									
Length of Blade	5 1/2	5 3/4	5 3/4	5 3/4	5 3/4	6 3/4	6 3/4	6 3/4	7	7 1/4	7 1/4	7 1/4	7 1/4	7 1/4	7 1/4	7 1/4	7 1/4	"
Per dozen	\$2.50	2.80	2.95	3.70	4.15	5.15	6.25	7.70										
In Sets of 12 Chisels, 1/4 to 1 1/2 inch	per set \$2.05																	
" " 1/4 to 2 "	" 3.55																	

FIRMER GOUGES, IN CANNEL

Size	1/8	3/16	1/4	5/16	3/8	7/16	1/2	5/8	3/4	7/8	1	1 1/8	1 1/4	1 1/2	1 3/4	2	inch.
Per dozen	\$1.75	1.75	1.75	1.85	2.05	2.10	2.15	2.35	2.55	2.90	3.05	3.85	4.35	5.30	6.50	8.00	

FIRMER GOUGES, IN CANNEL, MIDDLE SWEEP

Size	1/8	3/16	1/4	5/16	3/8	7/16	1/2	5/8	3/4	7/8	1	1 1/8	1 1/4	1 1/2	1 3/4	2	inch.
Per dozen	\$1.75	1.75	1.75	1.85	2.05	2.10	2.15	2.35	2.55	2.90	3.05	3.85	4.35	5.30	6.50	8.00	

FIRMER GOUGES, IN CANNEL, FLAT SWEEP

Size	1/8	3/16	1/4	5/16	3/8	7/16	1/2	5/8	3/4	7/8	1	1 1/8	1 1/4	1 1/2	1 3/4	2	inch.
Per dozen	\$1.75	1.75	1.75	1.85	2.05	2.10	2.15	2.35	2.55	2.90	3.05	3.85	4.35	5.30	6.50	8.00	

CAST STEEL TANGED PARING GOUGES



Size	1/4	5/16	3/8	7/16	1/2	5/8	3/4	7/8	1	1 1/8	1 1/4	1 1/2	1 3/4	2 inch.
Length of Blade.....	7 1/2	8	8 1/2	8 3/4	8 5/8	8 1/2	9 1/4	9 1/2	9 3/4	9 1/2	10	10 1/2	11	11 1/2
Per dozen	\$4.00	4.10	4.10	4.35	4.35	4.65	5.05	5.30	6.10	7.20	8.20	9.30	11.20	13.90
In Sets of 12 Gouges, 1/4 to 1 1/2 inches	per set \$5.45													
" " " 12 " 1/4 to 2 "	" " 6.75													

PARING GOUGES, FLAT SWEEP

Size.....	1/4	5/16	3/8	7/16	1/2	5/8	3/4	7/8	1	1 1/8	1 1/4	1 1/2	1 3/4	2 inch.
Per dozen	\$4.00	4.10	4.10	4.35	4.35	4.65	5.05	5.30	6.10	7.20	8.20	9.30	11.20	13.90

PARING GOUGES, TROWEL SHANK

Size.....	1/4	5/16	3/8	7/16	1/2	5/8	3/4	7/8	1	1 1/8	1 1/4	1 1/2	1 3/4	2 inch.
Per dozen	\$4.50	4.75	4.75	4.90	4.80	5.15	5.55	5.75	6.55	7.70	8.65	9.65	11.85	13.95

MILLWRIGHTS' CAST STEEL GOUGES

10-INCH BLADE



Size	1/4	5/16	3/8	7/16	1/2	5/8	3/4	7/8	1	1 1/8	1 1/4	1 1/2	1 3/4	2 inch.
Per dozen.....	\$4.45	4.80	4.80	5.10	5.10	6.00	6.55	7.10	7.85	10.00	12.00	14.50	17.15	
In Sets of 12 Chisels, 1/4 to 2-inch	per set \$9.10													

CAST STEEL TANGED TURNING GOUGES



Size	1/4	5/16	3/8	7/16	1/2	5/8	3/4	7/8	1	1 1/8	1 1/4	1 1/2	1 3/4	2 inch.
Length of Blade.....	6	6	6	6	6	6	6	6 1/4	6 1/2	6 3/4	6 3/4	7	7	"
Per dozen.....	\$2.50	2.80	2.80	3.15	3.15	3.40	3.65	4.50	5.05	6.00	8.45	10.10	12.35	

BLUED SOCKET JOINERS' CHISELS

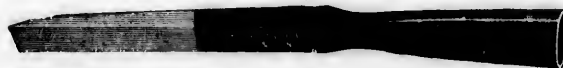

Size.....	1/4	5/16	3/8	7/16	1/2	5/8	3/4	7/8	1	1 1/8	1 1/4	1 1/2	1 3/4	2 inch.
Length of Chisel.....	9 1/2	9 1/2	9 1/2	9 1/2	9 1/2	9 1/2	9 1/2	9 1/2	9 1/2	9 1/2	10 1/4	10 1/4	10 1/4	10 1/4
Per dozen.....	\$3.95	3.95	3.95	3.95	3.95	4.20	4.50	4.80	5.30	5.85	6.40	7.30	8.50	9.75

Half-dozen in a package.

C. S. SOCKET FIRMER AND PARING CHISELS

SOCKET FIRMER CHISELS, HANDLED

6-INCH BLADE



Size.....	1/8	1/4	3/8	1/2	5/8	3/4	7/8	1	1 1/4	1 1/2	1 3/4	2 inch.
Per dozen.....	\$4.00	4.25	4.50	4.75	5.00	5.50	5.75	6.00	6.50	7.00	8.00	8.75
In Sets of 12 Chisels, 1/8 to 2 inch	per set \$6.00											

BEVELLED EDGE SOCKET FIRMER CHISELS, HANDLED

6-INCH BLADE

Size.....	1/8	1/4	3/8	1/2	5/8	3/4	7/8	1	1 1/4	1 1/2	1 3/4	2 inch.
Per dozen.....	\$5.25	5.50	5.75	6.00	6.25	6.75	7.00	7.25	7.75	8.25	9.25	10.00
In Sets of 12 Chisels, 1/8 to 2 inch	per set \$7.25											

SOCKET PARING CHISELS, HANDLED

8-INCH BLADE

Size.....	1/8	1/4	3/8	1/2	5/8	3/4	7/8	1	1 1/4	1 1/2	1 3/4	2 inch.
Per dozen.....	\$5.50	5.75	6.00	6.50	6.75	7.25	7.75	8.25	9.00	10.00	11.00	12.00
In Sets of 12 Chisels, 1/8 to 2 inch	per set \$8.00											

C. S. SOCKET FRAMING CHISELS, HANDLED

9-INCH BLADE



BEVEL BACK

Size.....	3/8	1/2	5/8	3/4	7/8	1	1 1/4	1 1/2	1 3/4	2	2 1/4	2 1/2	3 inch.
Per dozen	\$6.50	6.50	7.00	7.25	7.75	8.75	9.50	10.50	11.00	12.00	12.60	14.00	18.00

C. S. CORNER CHISELS, HANDLED



Size.....	3/4	7/8	1	1 1/4	1 1/2	1 3/4	2
Per dozen	\$15.00	16.00	17.00	18.00	19.50	22.00	

Half-dozen in a box.

S

CARPENTERS' CAST STEEL SLICKS



T SLICK



SOCKET SLICK

Socket or T Handle

Size.....	3	3½	4 inch.
Per dozen.....	\$20.00	22.00	25.00

1¾ 2 inch.
8.00 8.75
.....per set \$6.00

1¾ 2 inch.
9.25 10.00
.....per set \$7.25

1¾ 2 inch.
11.00 12.00
.....per set \$8.60

STANLEY'S ADJUSTABLE CHISEL GAUGE



Attach to ¼ inch Chisel (with bevelled edge up), and a shaving of any desired thickness for blind-nailing, or for inlaying wood strips in ornamental surface work.

No. 96 - Chisel Gauge, Steel Stock each \$0.25

CARVING TOOLS

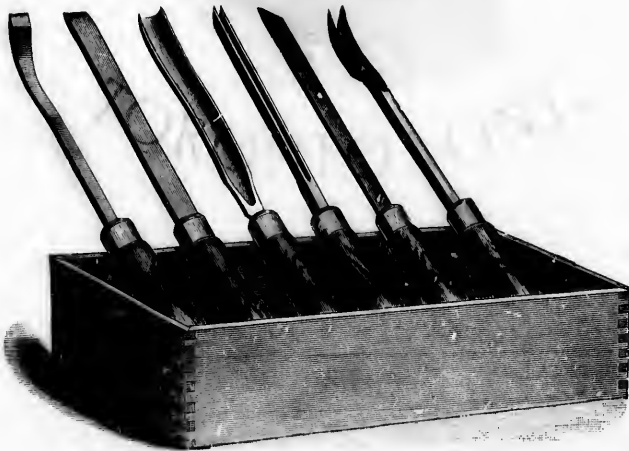

These Tools are forged from the Best Quality of Steel. They have Rosewood Handles, and are sharpened ready for use.

No. 1 - Six Tools in a Wooden Box per set 1.65

ADDIS' CARVING TOOLS

NO.		SIZE IN INCHES								
		1/32	1/16	1/8	3/16	1/4	5/16	3/8	1/2	3/4
1										
2										
3										
4										
6										
7										
8										
10										
11										
15										
17										
19										
21										
22										
23										
26										
29										
31										
35										

ADDIS' CARVING TOOLS

NO.		SIZE IN INCHES												
		$\frac{1}{8}$	$\frac{3}{16}$	$\frac{1}{4}$	$\frac{5}{16}$	$\frac{3}{8}$	$\frac{1}{2}$	$\frac{5}{8}$	$\frac{3}{4}$	$\frac{7}{8}$	1	$1\frac{1}{4}$		
38														
39														
40														
41														
43														
45														
58														

CARVERS' PUNCH

ADDIS' CARVING TOOLS

Price per dozen

Size	$\frac{1}{8}$	$\frac{3}{16}$	$\frac{1}{4}$	$\frac{5}{16}$	$\frac{3}{8}$	$\frac{7}{16}$	$\frac{1}{2}$	$\frac{5}{8}$	$\frac{3}{4}$	$\frac{7}{8}$	1	$1\frac{1}{4}$ inch.
Firmer Chisels.....Nos. 1, 2	\$2.40	2.40	2.40	2.40	2.40	2.40	2.40	2.40	2.80	3.20	3.40	4.00
Straight Gouges .. " 3 to 8	2.80	2.80	2.80	2.80	2.80	2.80	2.80	2.80	3.30	3.70	3.90	5.40
" " " " 10	3.20	3.20	3.20	3.20	3.20	3.20	3.20	3.20	3.60	4.80
Veining Tools	11	3.20	3.20	3.20
Front Bent Gouges " 15, 17, 19	3.40	3.40	3.40	3.40	3.40	3.40	3.40	4.20	5.20
Bent Chisels	" 21, 22, 23	3.00	3.00	3.00	3.00	3.00	3.00	3.00	3.00	5.20	7.20
Front Bent Gouges " 26, 29	3.40	3.40	3.40	3.40	3.40	3.40	3.40	3.40	3.80
" " " " 31	3.40	3.40	3.40	3.40	3.40	3.40	3.40	4.20	5.20
Back Bent Gouges " 35, 38	3.40	3.40	3.40	3.40	3.40	3.40	3.40	3.40	3.80
Parting Tools	" 39	4.20	4.20	4.20	4.20	4.20	4.20	5.20	6.50
" " " " 40	4.00	4.00	4.00	4.00	4.00	4.00	4.00	5.00	6.00
" " " " 41	4.20	4.20	4.20	4.20	4.20	4.20	4.20
" " " " 43	4.00	4.00	4.00	4.00	4.00	4.60	4.60
" " " " 45	4.20	4.20	4.20	4.20	4.20	4.20
Carvers' Punches. " 58	Nos. 2 to 13 or Assorted											per dozen \$3.10
Back Ground Tools, No. 1											" 3.10
Ladies' Carvers, in Sets of 6 , Assorted											per set 1.45
" " " " 12 , "											" 2.00

Carvers' Hickory Mallets, see page 201.

CARPENTERS' C. S. DRAWING KNIVES



No. 1. Section of Blade, Full Size.

RAZOR BLADE

Size.....	8	9	10	11	12 inch.
No. 1.....	per dozen	\$11.00	12.00	13.25	14.50
Barton's 1½ inch.....	“	23.40	25.20	27.00

BEVEL BACK

Size.....	8	9	10	11	12 inch.
No. 2.....	per dozen	\$8.50	9.50	10.50	11.50

FARMERS' C. S. DRAWING KNIVES



Size.....	8	9	10 inch.
Per dozen.....	\$14.00	15.00	16.00

WAGGONMAKERS' C. S. DRAWING KNIVES

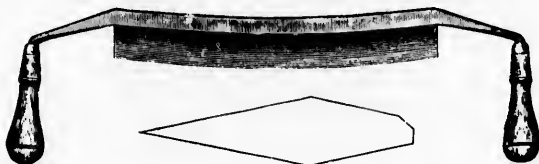

No. 30. Section of Blade, Full Size.

Size.....	8	9	10	11	12 inch.
No. 30.....	per dozen	\$11.50	12.50	13.50	14.75
Barton's Bevel Back.....	“	23.40	25.20	27.00	28.80

COACHMAKERS' NARROW C. S. DRAWING KNIVES



No. 31

Size.....	8	9	10	11	12 inch.
No. 31.....	per dozen	\$11.00	12.00	13.25
Barton's Coach, 1¼ in., Razor Blade.....	“	25.20	27.00	28.80
“ Narrow Carrige.....	“	21.00	23.40	25.20	27.00

ADJUSTABLE DRAWING KNIVES



- No. 59—Watrous Adjustable Drawing Knives, 9 inch Razor Blade per doz. \$21.15
 No. 3—Wilkinson “ “ “ 8 “ “ “ 41.45
 Drawing Knives, half-dozen in a package.

12 inch.
15.50
.....

12 inch.
12.50

IRON SPOKESHAVES



- No. 52—Double Iron, Straight Handle, 10 inch,
2 1/2 inch Cutter \$3.00



- No. 54—Adjustable, Straight Handle, 10 inch, 2 1/2
inch Cutter \$3.75



- No. 53—Adjustable, Raised Handle, 10 inch, 2 1/2
inch Cutter \$3.75



- No. 55—Model Double Iron, Hollow Face, 10 inch,
2 1/2 inch Cutter \$2.05

10 inch.
16.00



- No. 11—Straight Handle, 9 inch, 1 3/4 inch Cutter per doz. 1.90

12 inch.
15.50
.....



- No. 13—Double Cutter, Concave and Straight, 10 inch, 1 3/4 inch Cutter per doz. 3.55



- No. 1 per doz. 15.00

The circular shape of this tool enables it to work in smaller circles than other shapes. The angle of the knife is such that it cuts instead of scraping the grain of the wood. Either handle can be removed to work in cramped places.

Spokeshaves, half-dozen in a box.

12 inch.
.....
.....
28.80

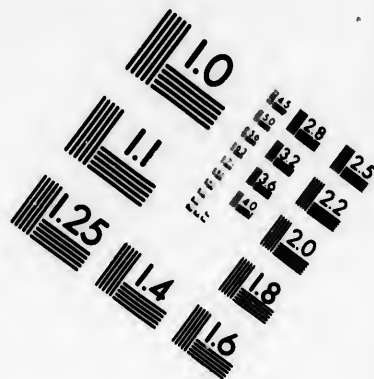
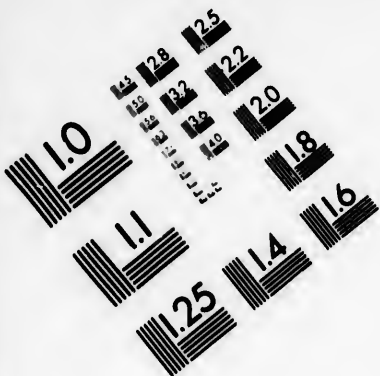

**IMAGE EVALUATION
TEST TARGET (MT-3)**

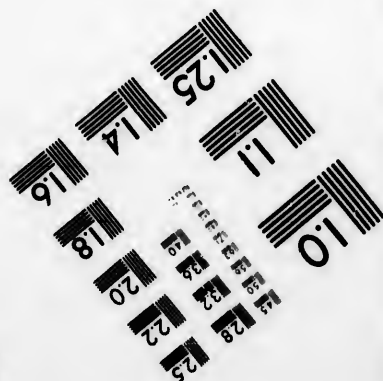
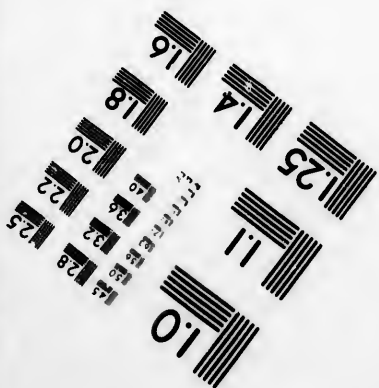
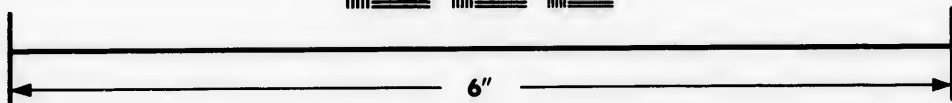
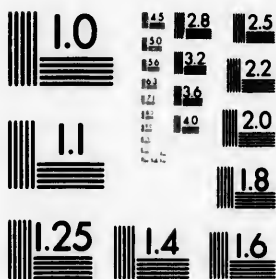

**Photographic
Sciences
Corporation**

23 WEST MAIN STREET
WEBSTER, N.Y. 14580
(716) 872-4503

1.4
1.6
1.8
2.0
2.2
2.5
2.8
3.2
3.6
4.0

10
11
12
13
14
15
16
17
18
19
20

WOOD SPOKESHAVES



Size.....		1 1/4	2	2 1/2	3	3 1/2 inch.
No. 670K —Beechwood, Kent.....	per doz.	\$2.70	2.70	2.70	3.15
" 670M —	Marples, extra quality "	3.35	3.35	3.35	4.00	4.50
" 675 —Boxwood	" " " "	5.00	5.00	5.00	5.60



Size.....		1 1/4	2	2 1/2	3 inch.
No. 671 —Beechwood, Marples, with Plate.....	per doz.	\$1.50	4.50	4.50	5.00

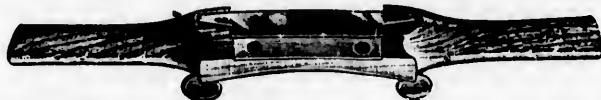

Size.....		2	2 1/2	3 inch.
No. 668D —Beechwood, Marples, with Thumb Screws.....	per doz.	\$5.00	5.00	5.00
" 668E —	" " " " Plate and Thumb Screws.....	7.00	7.00	7.00

BEST C. S. SPOKESHAVE IRONS



Size.....		2	2 1/4	2 1/2	2 3/4	3	3 1/2 inch.
Per doz.....		\$1.75	1.75	1.75	1.95	1.95	2.10

BEST C. S. PLANE IRONS



CUT



DOUBLE

Size.....		2	2 1/4	2 1/2	2 3/4	3	3 1/2 inch.
Sorby's Single or Cut.....	per doz.	\$3.05	3.20	3.65	4.05	4.25	4.80
" Double.....	"	5.00	5.85	6.45	7.10	7.50	8.15
Boker's Single or Cut.....	"	2.00	2.15	2.25
Sorby's Single C. S. Tothing Plane Irons, 2 inch, 20 teeth.....	per doz.						\$3.20
" " " " " " 2 1/2 " 30 ".....	"						3.50

BAILEY'S PLANE IRONS

Size.....		1 1/2	1 3/4	2	2 1/2	2 3/4	2 3/4 inch.
Single Irons.....	each	\$0.25	0.28	0.30	0.33	0.37	0.40
Double ".....	"	0.45	0.50	0.55	0.60	0.65	0.70
Single Block Plane Irons for No. 110 Plane.....	each						\$0.17
" " " " " " 9 1/2 ".....	"						0.20
" Tothing Plane Irons, 22, 28, 32 teeth.....	"						0.35
Cutters for Veneer Scrapers, Nos. 12 and 112	"						0.25

SPIRAL SCREW DRIVERS

ELECTRIC SPIRAL SCREW DRIVERS



No. 01—Length, Closed, 11½ inch; Open, 18 inch per dozen \$15.40
 " 02— " " 8 " " 12½ " " 12.80

Half-dozen in a box.

3½ inch.
4.50
.....

3 inch.
5.00

HOWARD ALLARD SCREW DRIVER

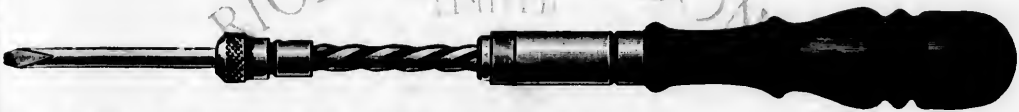

No. A1—Length, Closed, 10½ inch; Open, 16½ inch, with three Forged Steel Bits..... per dozen \$19.75

One in a box.

3 inch.
5.00
7.00

JONES' PATENT REVERSIBLE SCREW DRIVER

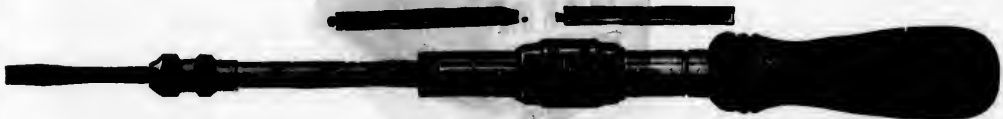

No. 1—Length, Closed, 11 inch; Open, 17 inch, with three Forged Steel Bits per dozen \$31.35
 " 2— " " 10 " " 15 " with two Plain Bits and one Slotted Bit..... " 21.00

The No. 2 is suitable for use on the Spoke Nipples of Bicycles.

One in a box.

3½ inch.
2.10

2¾ inch.
5.30
8.85
.....

doz. \$3.20
3.50

EUREKA SPIRAL SCREW DRIVERS

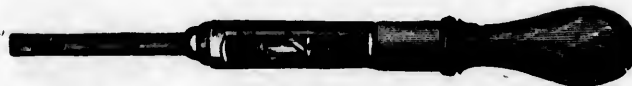

No. 6500—Length, Closed, 9 inch; Open, 13½ inch..... per dozen \$11.00
 " 6501— " " 10½ " " 17 " " 15.25

Half-dozen in a box.

2½ inch.
0.40
0.70
each \$0.17
" 0.20
" 0.35
" 0.25

SCREW DRIVERS

REID'S LIGHTNING SCREW DRIVER

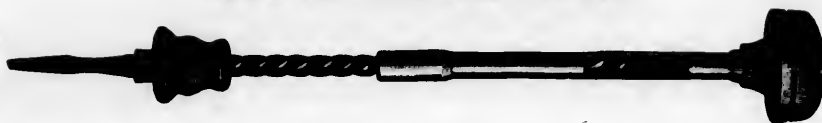

No. 1—Length, when Closed 15½ inch, with one Bit per dozen \$31.35
 " 2— " " " 12 " with three Bits " 25.10

No. 1 one only, No. 2 half-dozen in a box.

RATCHET SCREW DRIVERS



No. 2

No. 2—Pall Ratchet, Cocobolo Handle, length 7 inches, Plated Bit per doz. 10.50

One in a box.

BRIGHT C. S. SCREW DRIVERS, LONDON PATTERN



No. 710

Varnished Beechwood Handle, Heavy Brass Ferrule.

Size	3	4	5	6	7	8	9	10	12 inch.
No. 710—Murples' .. per doz.	\$2.35	2.85	3.30	3.00	4.80	5.50	6.30	7.75	9.85

OVAL BOX-HANDLED BRIGHT C. S. SCREW DRIVERS

Size	3	4	5	6	7	8 inch.
No. 717—Murples' .. per doz.	\$4.00	5.30	6.30	7.45	8.90	10.15

BRIGHT C. S. SCREW DRIVERS



No. 1

Beech Handle, Capped Ferrule, Forged Flat Steel Blade.

Size	3	4	5	6	7	8	10 inch.
No. 1	\$1.00	1.10	1.45	1.70	2.00	2.50	3.00



No. 3

Ebonized Handle, Nickeled Ferrule, Round Forged Steel Blade.

Size	3	4	5	6	7	8	10 inch.
No. 3	\$1.00	1.00	2.20	2.50	3.10	3.50	5.35

Half-dozen in a box.

AUTOMATIC DRILLS



No. 40

No. 40—Length Inclusive of Drill, as in Illustration, 10 3/4 inches.....per doz. \$22.50

Eight Drills are furnished with each tool, one each 1/16, 1/8, 3/16, 1/4, 5/16, 3/8, 7/16, 1/2 inch. The Chuck is of new design. To insert Drill the Sleeve of Chuck is turned to left the Drill inserted and Sleeve let go. The tool is made of Brass, Nickel-Plated and finely finished.

RICE LIMITED & SON

RECIPROCATING DRILLS



No. 50

No. 50—Length Inclusive of Drill, as shown in Illustration, 16 inches.....per doz. 30.00

Eight Drills are furnished with each tool, one each 1/8, 3/16, 1/4, 5/16, 3/8, 7/16, 1/2, 5/8 inch. This tool is so constructed that the Drill turns continuously to the right during both the forward and backward movement of the driver, Ball Bearings are used under the head of handle. The Chuck is the same design as No. 40.

DRILLS FOR Nos. 40 AND 50

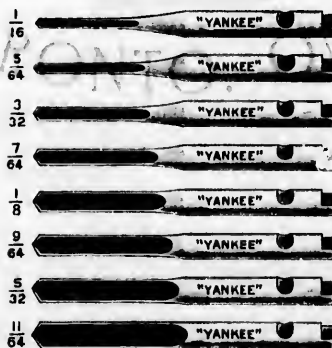

Extra Drills for Nos 40 and 50.....per set (8) 0.70

.....per dozen \$31.35
..... " 25.10

.....per doz. 19.50

10 12 inch.
7.75 9.85

7 8 inch.
8.80 10.15

8 10 inch.
2.50 3.00

8 10 inch.
3.50 5.35

SPIRAL RATCHET SCREW DRIVERS

RIGHT OR LEFT HAND



No. 30

No. 30—Length closed 13½ inches, open 19¼ inches, with 3 Forged Steel Bits..... per doz. \$20.25
One in a box.

DESCRIPTION.—It can be used as a rigid Screw Driver in any part of its length, as well as to push or ratchet screws in or out. The change from right to left hand for either push or ratchet is made by simply moving the slide to either end of the slot: when slide is moved towards the bit it works right-handed, either to push or ratchet the screw in—pushing the screw in as far as it will go—and without removing the hand from the driver or making any change whatever, turn the handle forward and backward and the screw is ratcheted into its place. When the slide is moved to end towards the handle, it works left-handed.



SHOWS INTERIOR VIEW OF PAWL AND RATCHET MECHANISM

The construction of ratchet and pawls permits of a very compact arrangement, making the tool convenient in size and of light weight, yet stronger in these vital points than any similar tool now made. Neither pawls nor ratchets can bend, break or get out of order. The friction in ratchet mechanism is so slight as to be hardly felt. The nuts working in spiral are of brass, and with the spiral grooves in rod are so designed that the wear has been reduced to a minimum.



SHOWS INTERIOR VIEW OF CHUCK

The chuck for holding the bits is simple in construction and positive in its hold on bits. When the sleeve of chuck is pulled down towards handle the bits can be put in, and when released it moves back to its place, holding bit fast. This sleeve is loose on chuck, so this end of tool can be readily held when in use, the chuck revolving inside of sleeve.

To INSERT BITS IN CHUCK, pull down the milled sleeve (towards handle), insert bit, then release sleeve.

To REMOVE BIT, pull sleeve down and pull out bit.

RATCHET SCREW DRIVERS



No. 10

Length.....	2	3	4	5	6	8	10	12	14	inch.
No. 10..... per doz.	\$5.25	6.65	7.25	7.90	8.25	10.05	12.50	13.75		

The construction of ratchet and pawls is such that neither can bend or break, wear or get out of order, and permits a very compact arrangement, making the tool more convenient in size and shape. For right hand or to ratchet a screw in, push the slide to end of slot towards bit; for left hand or to ratchet a screw out, push the slide towards handle of driver. If the slide is placed midway between ends of slot, the blade is held rigidly and the driver can be used as an ordinary screw driver with fixed blade.

SCREW DRIVERS



STANDARD
Mahogany Handles, Round Forged Steel Blade.

Size	2	3	4	5	6	7	8	10	12 inch.
Diameter of Shank	$\frac{1}{8}$	$\frac{3}{16}$	$\frac{1}{4}$	$\frac{1}{2}$	$\frac{5}{8}$	$\frac{3}{4}$	$\frac{7}{8}$	$1\frac{1}{8}$	$1\frac{1}{2}$
Standard.....per doz.	\$1.20	1.20	1.35	1.45	1.65	1.80	2.40	2.85	3.15



No. 400
Rosewood Finished Handle, Light Round Forged Steel Blade.

Size	2	3	4	5	6	7	8 inch.
Diameter of Shank	$\frac{3}{16}$	$\frac{1}{4}$	$\frac{5}{16}$	$\frac{3}{8}$	$\frac{7}{16}$	$\frac{1}{2}$	$\frac{5}{8}$
No. 400.....per doz.	\$2.55	2.80	3.00	3.25	3.75	4.00	4.25

CINCINNATI SCREW DRIVERS



Maple Wood Handles, Bright Round Steel Blades.

Length over all	14	16	18	20 inch.
Per dozen	\$5.00	5.50	6.25	6.75

Half-dozen in a Box.

SEWING MACHINE SCREW DRIVERS



No. 5844

No. 5844—Varnished Wood Handles, Bright Steel Blades	per gross	\$9.00
“ 3—Maple “ “ Flat “ “	“	4.50
“ 30—Enamelled “ “ Flat “ “	“	5.10

Nos. 3 and 30 the Handles are similar to the No. 1 Screw Drivers on page 156.
One dozen in a box.

VULCAN ALL-STEEL SCREW DRIVERS HOLLOW HANDLES



2 1/2, 3 1/2 and 4 inch, Full Size Cut of 2 1/2 inch.



5 and 6 inch.

Length of Blade	2 1/2	3 1/2	4	5	6 inch.
Full Length.....	5 1/2	6 1/2	7 1/4	9	10 1/4
Per dozen	\$4.40	5.00	5.65	10.30	11.90

Half-dozen in a box.

AWLS

HANDLED BRAD AWLS



No. 840—Kent's Oval Handle, Assorted	per gross	\$7.05
" 841—Marple's " " "	"	0.15

Quarter-gross in a box.

BRAD AWLS



Briggs' Shouldered Awls, Assorted, 30-41	per gross	\$2.00
" " " all Fine, 30-41	"	1.80
No. 214—Boker's Shouldered Awls, Assorted, 6-11	"	1.00
" " " " " 8-11	"	0.90
" 219— " " " " 6-11	"	1.15
" " " " " 8-11	"	1.05

PEG AWLS



No. 40, Patent Peg Awl.



Nos. 215 and 217, Shouldered Peg Awl.

No. 40—Patent Peg Awls, Assorted	per gross	\$0.00
" 215—Boker's Shouldered Peg Awls, Assorted, 10-14	"	0.70
" 217— " " " " 1-4	"	0.55

One gross in a box.

SEWING AWLS



No 51, Patent Sewing Awl.



Sewing Awls.



Harness or Saddlers' Awl.

No. 51—Patent Sewing Awl, Bent, Assorted	per gross	\$2.25
Briggs' Tanged Sewing Awl, Bent, Assorted sizes 83-91	"	2.35
" 204—Boker's " " " " 1-4	"	1.05
" " " " " 2-7	"	0.90
" 208— " " Harness " Straight " 2-7	"	0.70
" " " " " " 3-8	"	0.90
" " " " " " 4-8	"	0.90
" 212— " " Stabbing " round " 2-7	"	0.70
Briggs' Saddlers' " " " 18-150	"	2.50

Half gross in a box.

AWLS

HANDLED SCRATCH AWLS



No. 975—Baker's Scratch Awls.....per doz. 0.00
 " 976 " " " " " 0.70



No. 15—Socket Scratch Awls.....per doz. 2.15
 One dozen in a box.

gross \$7.05
 " 0.15

gross \$2.00
 " 1.80
 " 1.00
 " 0.90
 " 1.15
 " 1.05

AWLS AND TOOLS



gross \$0.00
 " 0.70
 " 0.55

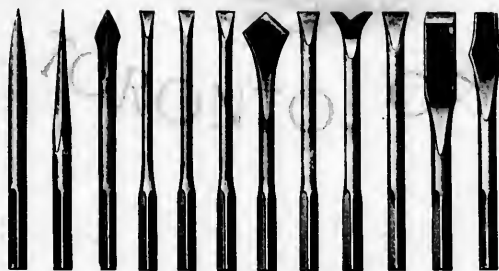

gross \$2.25
 " 2.35
 " 1.05
 " 0.90
 " 0.70
 " 0.60
 " 0.60
 " 0.70
 " 2.50

BRITTON'S COMBINATION

Nickel-Plated Caps. Rosewood Handles

No. 1—With 12 Tools, as illustrated.....per doz. \$13.00
 " 2— " 8 large Tools—3 Brad Awls; 1 each, Chisel, Reamer, Screw Driver, Tack Puller and Counter-sinkper doz. 16.25

These tool holders can be safely used with a hammer or mallet without material injury to the handle. The tools are best quality both in steel and temper. The tools in No. 2 are 2 1/2 inches in length. Half dozen in a box.

AWLS AND TOOLS

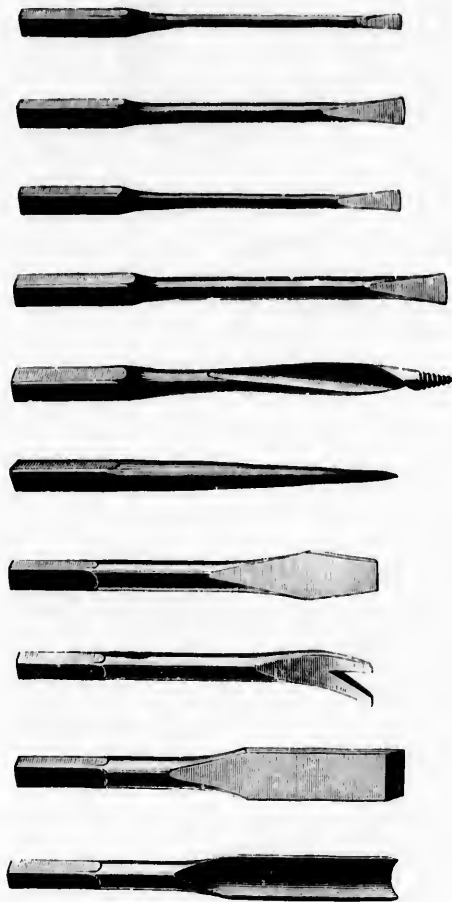

FULL SIZE

Tools made of superior Cast Steel, no Wrench required, Thumb Nut and Grip Nickel-Plated,
Handles Hollow to contain the Tools.

No. 60—Applewood Handle, 10 Tools, as per Cut	per doz.	\$7.15
" 61—Cocobolo " " "	"	9.40

Half-dozen in a box.

AWLS AND TOOLS



No. 405, BRAD AWL.



No. 408, BRAD AWL.



No. 414, GIMLET.



No. 415, REAMER AND SCRATCH AWL COMBINED.



No. 416, SCREW DRIVER.



No. 418, FILE.



No. 411, CHISEL.



No. 419, GOUGE.

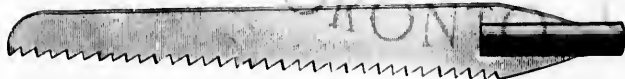

No. 420, SAW.



FULL SIZE

Extra large Handle and Tools.

Tools made of the Highest Grade of Cast Steel, no Wrench required, Thumb Nut and Grip Nickel-Plated, Handles Hollow to contain the Tools.

No. 70—Applewood Handle, 9 Tools, as per Cut	per doz.	\$16.00
" 72—Cocobolo	"	19.50

Half-dozen in a box.

AWLS AND TOOLS

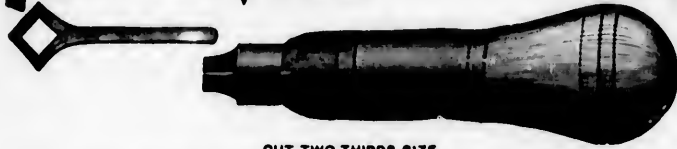

CUT TWO-THIRDS SIZE

Tools of superior Cast Steel, Handles Hollow to contain the Tools.

No. 120—Applewood Handle, 14 Brad Awls (and Tools Nos. 11, 13, 14, 15, 16, 17) per doz. \$4.00
Half-dozen in a box.

GIMLETS BOXWOOD HEAD

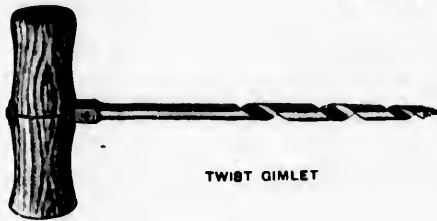

TWIST GIMLET



SHELL GIMLET



No. 750½	Boker's Shell Gimlets, Assorted 0 to 4.....	per gross \$4.75
" 751½	" Twist " " to ½nds.....	" 5.50
" 751½	" " " " ¼, ½, ¾, 1nds.....	" 4.00
" 751½	" " " " ½nds.....	" 6.30
" 751½	" " " " ¾nds.....	" 8.00
" 751½	" " " " 1nds.....	" 9.40
" 758	Kent's Shell " assorted ¼ to ½nds.....	" 12.00
" 759	Marples' " " ½ to ¾nds.....	" 15.25
" 766	Kent's Twist " " ¼ to ½nds.....	" 15.20
" 767	Marples' " " ½ to ¾nds.....	" 18.00
" 791	" Brewers " ½nds.....	per doz. 2.85

No. 701, 2 dozen, others, quarter-gross in a box.

GIMLET BITS



Size	2	3	4	5	6	7	8	9	10	11	12-Ends.
No. 240—Diamond Gimlet Bits, per doz.	\$1.35	1.35	1.35	1.35	1.35	1.35	1.35	1.35	1.35	1.35	1.00
Baker's Gimlet Bits,	\$0.05	0.05	0.05	0.05	0.05	0.05	0.05	0.75	0.85	0.05	1.00

SYRACUSE TWIST BITS FOR WOOD



Size	2	3	4	5	6	7	8	9	10	12-Ends.
Per dozen	\$1.00	1.00	1.00	1.75	2.00	2.50	3.00	3.50	3.50	4.00

BELL HANGERS' BITS FOR BELL HANGERS, TELEPHONE AND TELEGRAPH WORK



Size	3/16	1/4	5/16	3/8	7/16	1/2	5/8	11/16	3/4	7/8	1 inch.
Length, 18 inches, per doz.	\$7.00	7.00	7.50	8.00	9.00	10.00	12.00
" 21 " " "	\$9.00	9.00	10.50	10.00	11.00	12.00	14.00	15.00	16.00	18.00	20.00

COUNTERSINK BITS

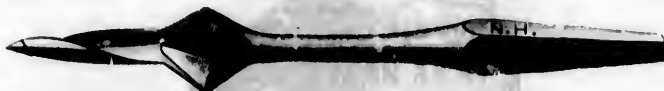

No. 280—Countersink Bits, Diamond Point, Assorted, 4 to 10-Ends per doz. \$2.00

CAST STEEL SHELL, NOSE AND SPOON BITS



Shell Bit.

Nose Bit.



Spoon Bit.

Size	1/4	3/16	1/4	5/16	3/8	7/16	1/2 inch.
Marples' Shell Nose or Spoon Bits, per doz.	\$1.75	1.75	1.75	1.00	2.00	2.40	2.75

BRIGHT C. S. CENTRE BITS



Size	1/4 to 3/8	7/16	1/2	5/8	3/4	7/8	1	1 1/8	1 1/4	1 3/8	1 1/2	1 5/8	1 3/4	1 7/8	2 inch.
No. 494—Marples', per doz.	\$1.00	1.75	1.75	1.80	1.85	2.00	2.20	2.00	2.00	3.25	3.50	3.00	4.35	4.80	5.40
" 591—Baker's " "	\$0.90	0.90	0.90	0.90	0.90	1.00	1.00	1.20	1.35	1.50	1.70	2.15	2.80	2.85	3.10

One dozen in a box.

...per doz. \$4.00

Twist Gimlet

per gross \$1.75
 " 5.50
 " 4.00
 " 0.30
 " 8.00
 " 0.40
 " 12.00
 " 15.25
 " 15.20
 " 18.00
 ...per doz. 2.85

AUGER BITS

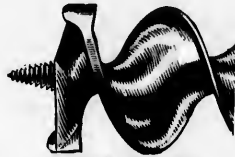

GILMORE'S PATTERN

GILMORE'S AND ROCKFORD SUPERIOR C. S. AUGER BITS

Gilmore's Pattern.

Size.....	3	4	5	6	7	8	9	10	11	10ths.
Per doz.....	\$1.00	3.50	3.50	3.75	3.75	4.00	4.25	4.50	5.00	
Size.....	12	13	14	15	16	17	18	20	10ths.	
Per doz.....	\$5.50	6.00	6.50	7.25	8.00	9.00	10.00	11.00		

ROCKFORD BLUED TWIST C. S. AUGER BITS

Jenning's Pattern.

Size.....	3	4	5	6	7	8	9	10	11	10ths.
Per doz.....	\$1.00	3.50	3.50	3.75	3.75	4.00	4.25	4.50	5.00	
Size.....	12	13	14	15	16	17	18	20	10ths.	
Per doz.....	5.50	6.00	6.50	7.25	8.00	9.00	10.00	11.00		



JENNING'S PATTERN

GENUINE RUSSELL JENNING'S C. S. AUGER BITS

Size.....	3	4	5	6	7	8	9	10	11	10ths.
Per doz.....	\$1.75	4.20	4.75	5.35	6.15	6.75	7.30	7.85	8.55	
Size.....	12	13	14	15	16	17	18	19	20	10ths.
Per doz.....	\$9.25	10.10	10.95	11.75	12.00	13.15	14.30	15.15	16.00	

IRWIN AUGER BITS

Double Cutter.



Size.....	4	5	6	7	8	9	10	11	12	13	14	15	16	17	18	20	10ths.
Per doz.....	\$3.00	3.40	3.80	4.40	4.80	5.20	5.00	6.10	6.00	7.20	7.80	8.40	9.00	9.00	10.20	11.40	

AUGER BITS IN SETS



No.	1	Gilmore's, in Wood Boxes, Thirteen Bits, one each, 4, 5, 6, 7, 8, 9, 10, 11, 12, 13, 14, 15, 16-10ths, per set															\$4.00
"	2	" " " " Six " " 4, 5, 6, 8, 10, 12-10ths.....															" 2.50
"	3	Rockford Superior, in Wood Boxes, Thirteen Bits, one each, 4, 5, 6, 7, 8, 9, 10, 11, 12, 13, 14, 15, 16-10ths.....															per set 3.40
"	4	Rockford Superior, in Wood Boxes, Six Bits, one each, 4, 5, 6, 8, 10, 12-10ths.....															" 1.50
"	30	Rockford, Jenning's Pattern, in Wood Boxes, Thirteen Bits, one each, 4, 5, 6, 7, 8, 9, 10, 11, 12, 13, 14, 15, 16-10ths.....															per set 4.15
"	300	Genuine Russell Jenning's Auger Bits in Sets, Thirteen Bits, 4 to 16-10ths.....															" 8.75
"	200	" " " " Six " " 4 to 12-10ths.....															" 3.20

FORSTNER AUGER BITS



Size	3/8	7/16	1/2	9/16	5/8	11/16	3/4	13/16	7/8	15/16	1	1 1/8	1 1/4	1 3/8	1 1/2	1 3/4	2
Each	\$0.70	0.85	0.85	1.00	1.00	1.20	1.20	1.35	1.35	1.50	1.50	1.60	1.75	1.75	1.90	2.05	13.50

FORSTNER MACHINE AUGER BITS

With 3/8 or 1/2 inch diameter Shanks. Length of Shank, 5 inches.

Size	3/8	7/16	1/2	9/16	5/8	11/16	3/4	13/16	7/8	15/16	1	1 1/8	1 1/4	1 3/8	1 1/2	1 3/4	2
Each	\$1.00	1.15	1.15	1.30	1.30	1.50	1.50	1.65	1.65	1.80	1.80	1.90	2.05	2.05	2.20	2.40	2.20

CLARK'S PATENT EXPANSIVE BITS



Small size, cutting from 1/2 to 1 1/4 inch, 2 Cutters with each Bit	per doz.	\$22.50
Large " " 3/4 to 3 " 2 " " " " " " " " " "	"	32.50

Extra Cutters

Nos.	1	2	3	4	5
Size	1/4 to 1/2	1/2 to 1 1/4	1/2 to 1 1/4	1 1/4 to 3	2 1/4 to 4 inch.
Per dozen	\$3.75	4.70	6.55	7.50	11.25

CLARK'S PATTERN EXPANSIVE BITS

LAVIGNE'S PATENT



Small size, cutting 1/2 to 1 1/4 inch	per doz.	\$22.50
Large " " 3/4 to 3 " " " " " " " " " " " "	"	32.50

Extra Cutters

Nos.	1	2	3	4	5
Size	1/4 to 1/2	1/2 to 1 1/4	1/2 to 1 1/4	1 1/4 to 3	2 1/4 to 4 inch.
Per dozen	\$3.75	4.70	6.55	7.50	11.25

One in a box; half-dozen in a large box.

CAR BITS



GILMORE'S CAR BITS

(Twist, 12 inches.)

Size	4	5	6	7	8	9	10	11	12	13	14	15	16	16ths.
Per dozen	\$7.50	7.50	7.50	9.00	10.25	11.25	12.75	13.25	15.50	16.50	17.75	18.75	20.50	



IRWIN PATENT CAR BITS

(Double Cutter, 12-inch Twist.)

Size	4	5	6	7	8	9	10	11	12	13	14	15	16	16ths.
Per dozen	\$6.00	6.80	7.60	8.80	9.60	10.40	11.20	12.20	13.20	14.40	15.00	18.00		

BRIGHT C. S. EYE AUGERS



SHORT

Size	1/2	3/8	1/4	3/8	1	1 1/4	1 1/2	1 3/4	2	2 1/2	3	inch.
Gilmore's..... per doz.	\$9.50	10.50	11.50	12.50	13.50	14.50	15.50	18.50	21.50	25.50	53.50	75.50
Boker's.....	\$3.90	4.50	5.10	5.70	6.40	7.30	8.10	9.00	11.70	13.80	20.30	34.50

LONG

Size	1	1 1/4	1 1/2	1 3/4	2	2 1/4	2 1/2	3	3 1/2	4	inch.
Gilmore's..... per doz.	\$14.00	16.00	19.00	22.00	26.00	44.00	54.00	76.00	96.00	123.00	
Boker's.....	\$ 6.40	8.10	9.90	13.80	20.30	34.50	48.00	70.00	

BRIGHT C. S. NUT AUGERS



Size.....	1/2	3/8	1/4	3/8	1	1 1/4	1 1/2	1 3/4	2	inch.
Per dozen.....	\$8.00	7.00	8.00	9.00	10.00	11.00	12.00	15.00	18.00	22.00

MILLWRIGHTS' BRIGHT C. S. AUGERS



Size	1/2	3/8	1/4	3/8	1	1 1/4	1 1/2	1 3/4	2	2 1/4	2 1/2	2 3/4	3	3 1/4	3 1/2	inch.
Each	\$1.00	1.12	1.25	1.38	1.50	1.63	1.75	1.87	2.00	2.12	2.25					
Size	1 3/4	1 1/2	1 1/4	1 1/8	1 1/16	1 1/2	1 3/8	1 1/4	1 1/8	1 1/16	1 1/4	1 1/8	2	inch.		
Each	\$2.38	2.50	2.63	2.75	2.88	3.00	3.12	3.25	3.37	3.50	3.75	4.00				

SHIP AUGERS



GILMORE'S C. S. SHIP AUGERS

WITH OR WITHOUT SCREW

Size	6	7	8	9	10	11	12	13	14	16ths.
Per dozen	\$7.50	7.50	7.50	9.00	9.00	10.50	10.50	12.00	12.00	
Size	15	16	17	18	19	20	22	24	16ths.	
Per dozen	\$13.50	13.50	15.00	15.00	16.50	16.50	18.00	21.00		

L'HOMMEDIU SHIP AUGERS

WITH OR WITHOUT SCREW

Size	6	7	8	9	10	11	12	13	14	16ths.
Per dozen	\$10.00	10.00	10.00	12.00	12.00	14.00	14.00	16.00	16.00	
Size	15	16	17	18	19	20	22	24	16ths.	
Per dozen	\$18.00	18.00	20.00	20.00	22.00	22.00	24.00	28.00		

BORING MACHINE AUGERS



Solid Cast Steel, Polished, Shanks $\frac{1}{2}$ inch diameter.

Size.....	$\frac{1}{2}$	$\frac{3}{4}$	$1\frac{1}{4}$	$1\frac{1}{2}$	$1\frac{3}{4}$	2 inch.
Per dozen.....	\$12.00	14.00	17.00	20.00	24.00	
In sets, one of each, $1\frac{1}{4}$, $1\frac{1}{2}$ and 2 inch.....						per set \$4.00

RUSSELL JENNINGS' MACHINE BITS



STRAIGHT SHANK

Shanks 2 inches long by $\frac{1}{2}$ inch diameter, 6 inch Twist.

Size.....	$\frac{1}{4}$	$\frac{5}{16}$	$\frac{3}{8}$	$\frac{7}{16}$	$\frac{1}{2}$	$\frac{5}{8}$	$\frac{3}{4}$	$\frac{7}{8}$	1 inch.
Per dozen.....	\$6.30	7.15	8.00	9.25	10.10	11.75	13.85	16.40	18.90

TAPER SHANK

Shanks $2\frac{1}{2}$ inches long, tapering $\frac{1}{4}$ to $\frac{3}{8}$ inch diameter, 6 inch twist.

Size.....	$\frac{1}{4}$	$\frac{5}{16}$	$\frac{3}{8}$	$\frac{7}{16}$	$\frac{1}{2}$	$\frac{5}{8}$	$\frac{3}{4}$	$\frac{7}{8}$	1 inch.
Per dozen.....	\$6.30	7.15	8.00	9.25	10.10	11.75	13.85	16.40	18.90

IRWIN MACHINE BITS



STRAIGHT SHANK

Shanks 2 inches long by $\frac{1}{2}$ inch diameter, 6 inch twist.

Size.....	$\frac{1}{4}$	$\frac{5}{16}$	$\frac{3}{8}$	$\frac{7}{16}$	$\frac{1}{2}$	$\frac{5}{8}$	$\frac{3}{4}$	$\frac{7}{8}$	1 inch.
Per dozen.....	\$4.50	5.10	5.70	6.60	7.20	8.40	9.90	11.70	13.50

RUSSELL JENNINGS' DOWEL BITS



Size.....	$\frac{5}{16}$	$\frac{3}{8}$	$\frac{7}{16}$ inch.
Straight Shank (Shank diameter of Bits).....	per doz.	\$4.75	5.35
Bit Stock.....		4.75	5.35
			6.20

PATENT CASTER BIT

Cutting Straight and Taper Tenons from $\frac{1}{8}$ to $1\frac{1}{2}$ diameter and $\frac{3}{4}$ inch length.

Price.....	per dozen	\$22.50
------------	-----------	---------

BEEBE'S PUMP TOOLS

These Tools are made of Solid Cast Steel, and Fully Warranted.

PUMP AUGERS



Price.....	per $\frac{1}{2}$ inch	1.45
------------	------------------------	------

PUMP REAMERS



Price.....	per $\frac{1}{2}$ inch	0.75
------------	------------------------	------

PUMP AUGER SOCKETS

Price.....	each	4.40
------------	------	------

HOLLOW AUGERS



CINCINNATI No. 1

Cutting $\frac{1}{4}$ to $\frac{1}{2}$ inch.....each \$7.00

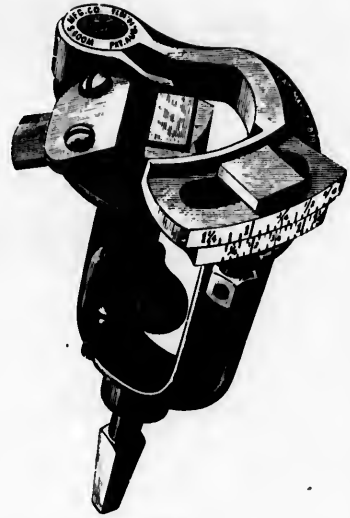

WOODS'

Cutting $\frac{1}{4}$ to $\frac{1}{2}$ inch.....each \$5.15



STEARNS' No. 2

Cutting $\frac{3}{8}$ to 1 inch.....each \$6.00



STANDARD

One size.....each \$2.25
Plates..... " 0.80



CINCINNATI No. 3

Cutting $\frac{1}{4}$ to $\frac{1}{2}$ inch.....each \$7.00

In the Standard, the Plates are separate from the frame and interchangeable. One frame and one plate constitute the Auger. Plates are of the following sizes, viz., $\frac{3}{8}$, $\frac{7}{16}$, $\frac{1}{2}$, $\frac{5}{8}$, $\frac{3}{4}$, $\frac{7}{8}$ and 1 inch, and are sold separate from the frame when desired.

One in a box.

AUGER BIT GUIDE

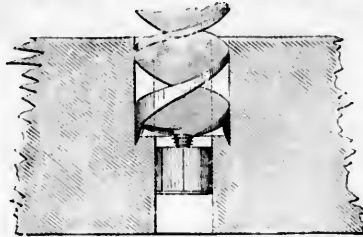

This Guide is made of Solid Brass with a soft Metal Centre so as to accommodate itself to the Screw Point of any Screw Auger without injury to the Screw.

In sets of 12 sizes, $\frac{1}{4}$ to $1\frac{1}{8}$ inch per set \$1.35

One set in a box.

AUGER BIT GAUGE



Adapted for any size Bit up to $\frac{1}{2}$ inch.

Garrett's Patent Auger Bit Gauge, Nickel-Plated per doz. 5.10

IMPROVED BIT WRENCHES

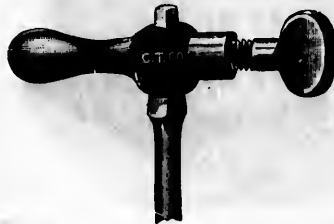

Cincinnati Bit Wrenches per doz. 3.15

DOWEL AND SPOKE POINTERS



DOWEL POINTER, FULL SIZE

No. 00—Dowel Pointer, Pointing from 0 to $\frac{1}{4}$ inches per doz. 5.65

" 0—Spoke " " " 0 to $1\frac{1}{4}$ " " 8.10

" 1— " " " " 0 to $1\frac{1}{2}$ " " 11.25

The No. 1 Spoke Pointer has Graduated Adjustable Shank.

Half-dozen in a box.

CLARK'S DOUBLE-CUT COUNTERSINKS

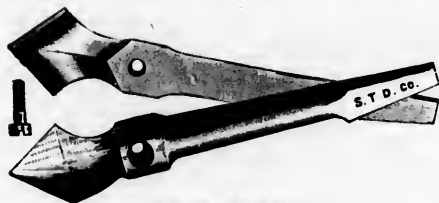

OPEN FOR SHARPENING



CLOSED FOR USE

Make the smoothest work. Can be kept as sharp as a plane.

Polished per doz. \$5.75

ADJUSTABLE STEEL COUNTERSINK



Adjusts to any Bit from $\frac{1}{8}$ to $\frac{1}{2}$ inch per doz. \$4.50

PLUG CUTTERS

Size		$\frac{1}{2}$	$\frac{9}{16}$	$\frac{5}{8}$ inch.
Plug Cutters, extra cast steel.....	per doz.	\$7.00	7.00	7.00

ENTERPRISE BUNG-HOLE BORER

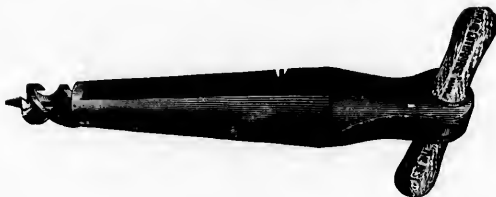

No. 1—Small size, boring from $\frac{3}{8}$ to $1\frac{1}{2}$ inches.....	each	\$2.10
" 2—Medium " " $1\frac{1}{4}$ to 2 "	"	2.80
" 3—Large " " $1\frac{1}{2}$ to 3 "	"	4.20

The main advantages of this Borer are—it bores a complete round hole, regular taper, holds its own chips, and prevents them from entering the cask. Being furnished with a round lip bit, smoothness in boring is ensured. To sharpen the stock or reamer, file the inside of the slot only.

BUNG STARTERS



Bung Starters, Maple, Dovetailed Head per doz. \$3.35

BRIGHT C. S. SCREW DRIVER BITS



No. **515** —Marples' Plain.....per doz. \$1.75
 " **653E**—Boker's "....." 1.10

BRIGHT C. S. FORKED SCREW DRIVER BITS



No. **516** —Marples' Forked.....per doz. 1.90
 " **654E**—Boker's "....." 1.20

STANDARD C. S. SCREW DRIVER BITS

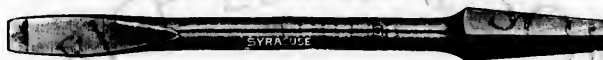

Nos..... **8** **10** **12** **16**
 Width of point..... $\frac{1}{4}$ $\frac{3}{8}$ $\frac{1}{2}$ $\frac{3}{4}$ inch.
 Length 4 inches.....per doz. \$3.70 3.70 3.70 4.45

BRIGHT C. S. REAMERS



No. **517** —Marples' Square Reamers.....per doz. \$2.10
 " **518** — " Half Round "....." 2.10
 " **519** — " Octagon "....." 2.60
 " **655E**—Boker's Square "....." 1.35
 " **657E**— " Half Round "....." 1.40
 " **672E**— " Octagon "....." 1.65

BRIGHT C. S. ROSE COUNTERSINKS



No. **530** —Marples', assorted large.....per doz. 2.25
 " **651E**—Boker's, "....." 1.25

BRIGHT C. S. SNAIL COUNTERSINKS



No. **527** —Marples', assorted large.....per doz. 2.10
 " **650E**—Boker's "....." 1.25

BRIGHT C. S. FLAT HEAD COUNTERSINKS



No. **524** —Marples', assorted large.....per doz. 1.00
 " **652E**—Boker's "....." $\frac{1}{4}$ to $\frac{3}{8}$ inch....." 1.20
 " **50** —Syracuse, fits Tire Bolts....." 3.80
 " **80** — " fits Wood Screws....." 3.80

NAIL SETS

SUPERIOR CUP POINT



KNURLED BODY

No. 11—Three Sizes, Points 2, 3 and 4-32nds, assorted per doz. \$1.75



CORRUGATED BODY

No. 12—Four Sizes, Points 2, 3, 4 and 5-32nds, assorted per doz. 1.00



No. 4—Superior, Square, Blued, Cup Point, 2, 3 and 4-32nds	per doz.	1.50
" 819—Marple's, " Bright	"	0.90
" 820— " " (Brad)	"	0.90
" 927½—Boker's " Black, Cup Point	"	0.65
" 927¾— " " " Diamond Point	"	0.65

RIVET PUNCHES



No. 13—Assorted, ¼ to ½ inch per doz. 2.00

PRICK PUNCHES



No. 10—Pointed per doz. 1.85

CENTRE PUNCHES



No. 14 —Superior, 3 Sizes, 8, 10 and 12-32nds, assorted.....	per doz.	1.85
" 931E—Boker's, ½ x 5 inch.....	"	1.85
" 931E— " ¾ x 6 "	"	2.60

One dozen in a box.

IMPROVED MARKING AND MORTISE GAUGES

STANLEY'S PATENT

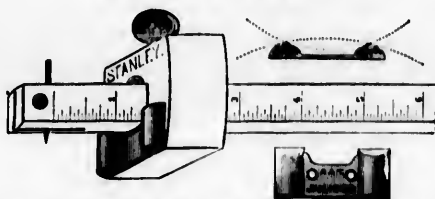

The Brass Face, with two ribs or protections, attached to one side of the Gauge-head (see Engraving), will enable the owner to run a gauge-line with perfect steadiness and accuracy around curves of any degree, and either concave or convex. The Gauge-head is reversible, and the flat side can be used for all ordinary work.

MARKING GAUGES

No. 161—Beechwood, Boxwood Thumb Screw, Oval Bar, Steel Point.....	per dozen	\$2.00
" 162— " " " " Adjusting Steel Point.....	"	3.00
" 164— " " " " Plated Head, Adjusting Steel Point.....	"	3.75
" 165—Boxwood, Brass Thumb Screw and Shoe, Plated Head, Adjusting Steel Point.....	"	6.00

MORTISE GAUGES

No. 171—Double Gauge (Marking and Mortise), Beechwood, Plated Heads and Bars, Brass Thumb Screws and Shoes.....	per dozen	\$9.00
" 172—Double Gauge (Marking and Mortise), Beechwood, Boxwood Thumb Screws.....	"	5.00
" 173—Boxwood, Brass Slide, Plated Head, Brass Thumb Screw and Shoe.....	"	9.00

Nos. 161 to 164, one dozen in a box; Nos. 165 to 173, half-dozen.

WOOD SCREW-BOXES AND TAPS



Size	3/8	1/2	5/8	3/4	7/8	1	1 1/4	1 1/2	1 3/4	2	2 1/2	inch.
No. 845—Marples'.....each	\$1.55	1.55	1.55	1.80	2.00	2.25	2.45	2.70	3.00	5.75	9.30	
" 1477—Boker's..... "	0.70	0.75	0.85	1.00	1.10	1.20	

BENCH STOPS

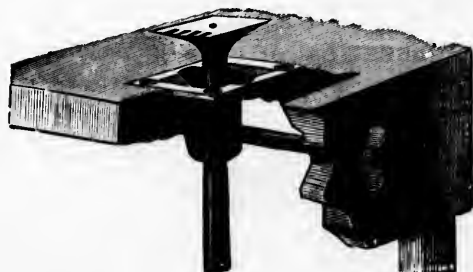

No. 1



No. C1408

No. 1—Cincinnati, with Side Screw Adjustment.....per dozen \$14.35

" C1408—Iron Bench Stops, with Screw Adjustment.....per dozen 5.10

BARTON'S COOPERS' TOOLS

COOPERS' AXES



- No. 119—Black, No. 1, Tight Barrel each \$1.50
- " 120—Bright, No. 1, " " 5.00
- " 121—Black, No. 2, Flour Barrel " 3.75
- " 122—Bright, No. 2, " " 4.15

COOPERS' ADZES



- No. 123—Black, No. 1, Tight Barrel each \$4.15
- " 124—Bright, No. 1, " " 4.50
- " 125—Black, No. 2, Flour Barrel " 3.75
- " 126—Bright, No. 2, " " 4.15
- Horton Pattern, 5 to 5½ lbs. " 5.80

HEADING SHAVES



- Size 8 9 10 11 12 14 inch.
- No. 127 each \$2.00 2.30 2.55 2.85 3.15 3.65

HOOP SHAVES



- Size 7 8 inch.
- No. 132 each \$1.00 1.85

BACKING SHAVES



- No. 129 —7 in., Ordinary each \$1.75
- " 129S—7 in., Straighter " 1.75
- " 128 —Stave Shaves " 1.75

HOLLOWING SHAVES



- Size 5½ 7 inch.
- No. 130 each \$1.75 1.75

CHAMPERING KNIVES

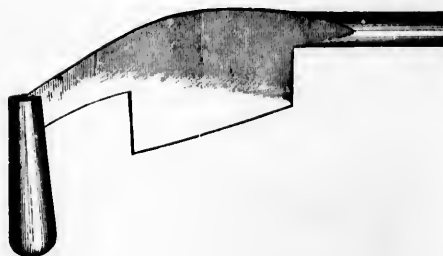

- No. 134—5 in., Right Hand each \$2.55
- " 134—5½ in., " " 2.85
- " 135—6 in., Cleveland Pattern, 7 to 8 lbs. " 3.75

COOPERS' TOOLS

SPOKESHAVES



No. 136 — Boston Pattern, Black.....	each	\$1.75		No. 138A — Cleveland Pattern.....	each	\$1.75
“ 138B — “ “ Bright.....	“	2.00				
“ 225 — Extra Knives.....	“	0.50				

COOPERS' V IRONS



COOPERS' RAISING IRONS



COOPERS' VISES

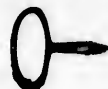

No. 143.....	per dozen	\$4.15		No. 140.....	per dozen	\$5.00		No. 158.....	per dozen	\$8.25
--------------	-----------	--------	--	--------------	-----------	--------	--	--------------	-----------	--------

COOPERS' INSHAVES



COOPERS' SCRAPERS



No. 137 — Two Handles.....	each	\$1.00		No. 139.....	each	0.85
“ 136 — One “.....	“	1.00				

COOPERS' DRIVERS



No. 169 — Coopers' Hickory Driver, with Iron Rings.....	each	0.50
“ 166 — “ “ Iron Drivers, Short and Oval to 2 1/2 inch.....	“	1.00

COOPERS' HAMMERS



No. 162.....	each	2.50
--------------	------	------

COOPERS' TOOLS

DOWEL MACHINES

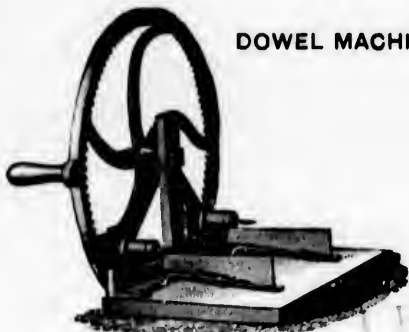

DOWEL FORMS



No. 150—Coopers' Dowel Machines each \$7.50
 " 149— " " Forms " 2.10

COOPERS' CROZES

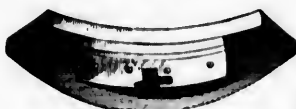

No. 172 —V Crozes, Lignum-vite Beads, complete with V Irons each \$2.30
 " 172B—Lignum-vite Beads and Bolts, without V Irons " 1.40
 178A—Tight Barrel Crozes, Maple Boards, 15, 40 and 60 gullons " 2.00

COOPERS' HOWELS



No. 177A—Tight Barrel, Applewood each 2.00

COOPERS' LEVELERS



No. 192—Levelers, Applewood each 1.80

COOPERS' HEAD FLOATS



No. 196A—With Apple Face each 5.80

COOPERS' JOINTERS



No. 198—Coopers' Short, Maple, Jointers, 2½ feet long, Double Irons per pair 5.30
 A pair of Jointers consists of one Stave and one Heading Jointer.

COOPERS' TRUSS HOOPS

No. 1 x 17½—Flour Barrel, 6 to set per set 6.75
 " 2 x 17½— " 6 " " 0.25
 " 1 x 14½—Fish Barrel, 6 " " 5.05
 " 1 x 17½—Bilge Hoops each 1.10
 " 1—Head Hoops " 1.10

These Hoops are made of the best young second-growth hickory, and are rounded and dried on heated cylinders to make them perfectly round and accurate gauge. They are the regular ordinary style Hoop, riveted and burred with two extra cross rivets.

CARPENTERS' PLANES



SMOOTH



JACK

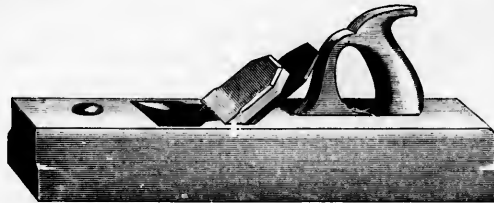

FORE

BENCH PLANES

With Start Pins and best Cast Steel Double Irons.

No. 5—Smooth Plane, 2 $\frac{1}{4}$ inch Cutter	each	\$1.05
" 6— " " 2 $\frac{1}{4}$ " "	"	1.10
" 7— " " 2 $\frac{1}{4}$ " "	"	1.15
" 12—Handled Smooth Plane, 2 $\frac{1}{4}$ inch Cutter	"	1.70
" 18—Jack Plane, 2 $\frac{1}{4}$ inch Cutter, Length 18 inches	"	1.30
" 19— " " 2 $\frac{1}{4}$ " " 18 "	"	1.40
" 20—Fore " 2 $\frac{1}{4}$ " " 22 "	"	1.85
" 30—Jointer " 2 $\frac{1}{4}$ " " 26 "	"	2.00
" 40— " " 2 $\frac{3}{8}$ " " 26 "	"	2.10

MATHIESON'S SCOTCH BENCH PLANES

Size	each	2 $\frac{1}{8}$	2 $\frac{1}{4}$	2 $\frac{3}{8}$	inch.
Smooth Plane, Cast Steel Double Irons	each	\$1.00	1.70	1.80	
Handled Smooth, " " "	"	2.00	2.70	2.90	
Jack, " " "	"	2.00	2.10	2.90	
Size	each	22 x 2 $\frac{1}{2}$	24 x 2 $\frac{1}{2}$	26 x 2 $\frac{1}{2}$	inch.
Trying Plane, Cast Steel Double Irons	each	\$2.70	2.90	3.00	



MATCH



SKREW RABBIT

MATCH PLANES

Nos.	68	69	70	71
Size	$\frac{1}{4}$ to $\frac{1}{2}$	$\frac{3}{8}$	$\frac{7}{8}$	1 inch.
Per pair	\$1.30	1.40	1.50	1.60

TWIN MATCH

Nos.	78	79	80
Size	$\frac{3}{8}$	$\frac{1}{2}$	1 inch.
Each	\$1.40	1.50	1.60

HANDLED FLOORING MATCH

No. 81— $\frac{3}{4}$ to 1 inch	per pair	\$2.50
---------------------------------	----------	--------

SKREW RABBIT

Nos.	61	62	63	64	65
Size	$\frac{1}{4}$ to 1	$\frac{1}{2}$	$\frac{3}{4}$	1 $\frac{1}{8}$	2 inch.
Each	\$0.65	0.70	0.75	0.80	0.90

MATHIESON'S SCOTCH SKREW RABBIT PLANES

Size	$\frac{7}{8}$ to 1 $\frac{1}{4}$	1 $\frac{1}{2}$	1 $\frac{3}{4}$	2 inch.
Each	\$1.00	1.15	1.30	1.40



PLANES

HOLLOWS AND ROUNDS



Nos.....	243	244	245	246	247	248
Size.....	2 to 8	10 to 12	14	16	18	20
Per pair.....	\$1.10	1.15	1.20	1.30	1.35	1.40

MATHIESON'S SCOTCH HOLLOW AND ROUNDS

Size Nos.....	2 to 12	14	16	18	20
Per pair.....	\$1.75	1.80	2.00	2.35	2.80



SIDE BEAD

CENTRE BEAD

SINGLE BOXED SIDE BEADS

Nos.....	87	88	89	90	91	92	93
Size.....	$\frac{1}{4}$ to $\frac{1}{2}$	$\frac{3}{8}$	$\frac{1}{2}$	$\frac{3}{4}$	1	1 $\frac{1}{4}$	1 $\frac{1}{2}$ inch.
Per pair.....	\$0.60	0.65	0.70	0.80	0.90	1.00	1.10

CENTRE BEADS

Nos.....	99	100	101	102	103	104
Size.....	$\frac{1}{4}$ to $\frac{1}{2}$	$\frac{3}{8}$ to $\frac{1}{2}$	$\frac{1}{2}$	$\frac{3}{4}$	1	1 inch.
Each.....	\$0.70	0.80	0.90	0.95	1.00	1.10

MATHIESON'S SCOTCH SIDE AND CENTRE BEADS

Side Bead, $\frac{1}{8}$, $\frac{1}{16}$, $\frac{1}{4}$, $\frac{3}{8}$, $\frac{1}{2}$, $\frac{3}{4}$ or 1 inch.....	each	\$1.00
Centre Bead, $\frac{1}{8}$, $\frac{1}{16}$, $\frac{1}{4}$, $\frac{3}{8}$ or 1 inch.....	"	1.35



NOSING

No. 208 — $\frac{1}{2}$ to $\frac{3}{4}$ inch Dado Plane, with Iron Side Stop.....	each	\$1.20
" 209 —" " " " " " " ".....	"	1.25
" 225 — $\frac{1}{2}$ inch Nosing " " " Two Irons.....	"	1.40
" 226 — $\frac{1}{2}$ " " " " " " " ".....	"	1.45

MATHIESON'S SCOTCH STEP NOSING PLANES

WITH TWO IRONS

Size.....	1$\frac{1}{4}$	1$\frac{1}{2}$	1$\frac{1}{2}$ inch.
Each.....	\$2.00	3.00	3.20



FILLETSTERS

No. 253 —Plain.....	each	\$1.75
" 254 —Single Slip.....	"	2.00
" 255 —Brass Screw Stop.....	"	2.00

.....each \$1.05
" 1.10
" 1.15
" 1.70
" 1.90
" 1.40
" 1.85
" 2.00
" 2.10

2 $\frac{3}{8}$ inch.
1.80
2.30
26 x **2** $\frac{1}{2}$ inch.
3.00

71
1 inch.
1.00
80
1 inch.
1.00

er pair \$2.50

65
2 inch.
0.90

2 inch.
1.40

PLANES



TABLE PLANES



QUARTER ROUNDS



STAIR COVES, OR SCOTIAS



TABLE PLANE, WITH GAUGE

No. **272**— $\frac{3}{4}$ to $\frac{5}{8}$ inch.....per pair \$1.25

QUARTER ROUNDS

Nos.....	210	211	212	213	214	215
Size.....	$\frac{1}{4}$ to $\frac{3}{4}$	$\frac{3}{8}$ to 1	$\frac{1}{4}$	$\frac{1}{4}$	$\frac{1}{4}$	$\frac{1}{4}$ inch.
Each.....	\$0.75	0.80	0.90	1.00	1.10	1.20

COVES, OR SCOTIAS

Nos.....	216	217	218	219	220	221
Size.....	$\frac{1}{4}$ to $\frac{3}{4}$	$\frac{3}{8}$ to 1	$\frac{1}{4}$	$\frac{1}{4}$	$\frac{1}{4}$	$\frac{1}{4}$ inch.
Each.....	\$0.75	0.80	0.90	1.00	1.10	1.20



GRECIAN OGEE

No. 157 — $\frac{3}{4}$ x $\frac{3}{4}$ to $\frac{1}{2}$ x1 inch.....	each \$1.05
" 158 — $\frac{1}{2}$ x $\frac{1}{2}$ " $\frac{1}{2}$ x $\frac{1}{2}$ "	" 1.25
" 159 — $\frac{1}{2}$ x $\frac{1}{2}$ " 1x2 "	" 1.35



GRECIAN OGEE AND BEVEL

No. 166 — $\frac{3}{4}$ x $\frac{3}{4}$ to $\frac{1}{2}$ x1 inch.....	each \$1.20
" 167 — $\frac{1}{2}$ x $\frac{1}{2}$ " $\frac{3}{4}$ x $\frac{1}{2}$ "	" 1.30
" 168 — $\frac{1}{2}$ x $\frac{1}{2}$ " 1x2 "	" 1.40



QUIRK OGEE AND BEAD

No. 155 — $\frac{3}{4}$ x $\frac{3}{4}$ to $\frac{1}{2}$ x1 inch.....	each \$1.20
" 156 — $\frac{1}{2}$ x $\frac{1}{2}$ " 1x2 "	" 1.30

SASH PLANES

With Two Irons.



OGEE SASH



SASH OVOLOS



No. 230 — $1\frac{1}{2}$ to $1\frac{1}{2}$ inch.....	each	\$1.50		No. 228 — $1\frac{1}{2}$ to $1\frac{1}{2}$ inch.....	each	\$1.50
" 231 — $1\frac{1}{2}$ " 2 "	"	1.00		" 229 — $1\frac{1}{2}$ " 2 "	"	1.00



LAMB TONGUE SASH

No. 232 — $1\frac{1}{2}$ to $1\frac{1}{2}$ inch.....	each \$1.50
" 233 — $1\frac{1}{2}$ " 2 "	" 1.00



GOTHIC SASH

No. 234 — $1\frac{1}{2}$ to $1\frac{1}{2}$ inch.....	each \$1.50
" 235 — $1\frac{1}{2}$ " 2 "	" 1.00



BEVEL SASH

No. 236 — $1\frac{1}{2}$ to $1\frac{1}{2}$ inch.....	each \$1.50
" 237 — $1\frac{1}{2}$ " 2 "	" 1.00

For any of the above Sash Planes, Boxed, add 25c. to list.

PLOW PLANES

No. 258 —Ironwood, Screw Arms.....	each	\$6.00
" 259 — " " " Handled.....	"	7.00
" 260 —Boxwood, " " "	"	7.50
" 261 — " " " Handled.....	"	8.50
" 262 —Rosewood, Box Screw Arms	"	9.00
" 263 — " " " Handled.....	"	10.00
" 264 —Boxwood " " "	"	10.00
" 265 — " " " Handled.....	"	11.00

IRON PLANES

STANLEY IRON BLOCK PLANES



No. 101—Block Plane, 3½ inches in length, 1 inch Cutter.....each \$0.20



No. 110—Block Plane, 7½ inches in length, 1½ inch Cutter.....each \$0.60



No. 102—Block Plane, 5½ inches in length, 1½ inch Cutter.....each 0.40



No. 130—Block Plane (Double-Ender), 8 inches in length, 1½ inch Cutter.....each 0.80



No. 103—Block Plane, Adjustable, 5½ inches in length, 1½ inch Cuttereach 0.60

This Plane has two slots, and two Cutter Seats. It can be used as a Block Plane, or, by reversing the position of the cutter and the clamping wedge (see dotted lines in the engraving), it can be used to plane close up into corners.

BAILEY'S ADJUSTABLE BLOCK PLANES WITH IMPROVED THROAT ADJUSTMENT



No. 9½—Block Plane, 6 in. length, 1½ in. Cutter.....each \$1.50

" 15— " " 7 " " 1½ " " " 1.60

" 16—Block Plane, Nickel Trimmings, 6 in. length, 1½ in. Cuttereach 1.05

" 17—Block Plane, Nickel Trimmings, 7 in. length, 1½ in. Cuttereach 1.75



No. 9½—Rosewood Handle, 6 in., 1½ in. Cutter.....each \$1.75

" 15½— " " 7 " 1½ " " " 1.85

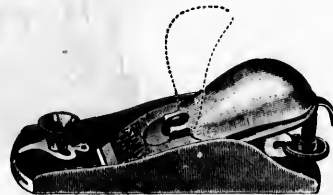

The Knuckle-Joint in the cap makes it a lever too; and placing the cap in position, will also clamp the Cutter securely in its seat.

No. 18—Nickel Trimmings, 6 in. length, 1½ in. Cutter.....each \$1.75

" 19— " " 7 " 1½ " " " 1.85

STANLEY IRON RABBIT PLANES



No. 75



No. 98

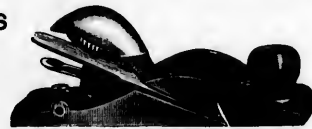

No. 140

No. 75—Bull Nose, Rabbet Plane, 4 inches in length, 1 inch Cutter.....each \$0.50

" 98—Side Rabbet Plane, length 4 inches, Right Hand.....each 1.35

" 99— " " 4 " Left "each 1.35

" 140—Rabbet and Block Plane with Detachable Side, length 7 inches, 1½ inch Cutter.....each 1.80

The No. 140 Plane has Detachable Side, can be easily changed from a Block Plane to a Rabbet Plane or vice versa. The Cutter is set on a skew. No. 101 half-dozen, all others one in a box.

IRON PLANES

BAILEY'S PATENT ADJUSTABLE



Nos. 3 to 4½



Nos. 5 to 8

No. 3	— Smooth Plane,	8 inches in Length,	1½ inch Cutter		each	\$3.00
" 4	"	" 9	" 2	"	"	3.25
" 4½	"	" 10	" 2½	"	"	3.75
" 5	— Jack	" 14	" 2	"	"	3.75
" 6	— Fore	" 18	" 2½	"	"	4.75
" 7	— Jointer	" 22	" 2½	"	"	5.50
" 8	"	" 24	" 2½	"	"	6.50



Nos. 104 and 105, Wrought Steel Stock

No. 104	— Smooth Plane,	9 inches in Length,	2½ inch Cutter		each	2.75
" 105	— Jack	" 14	" 2½	"	"	3.50

BAILEY'S WOOD PLANES



Nos. 22 to 24



Nos. 35 to 37

No. 22	— Smooth Plane,	8 inches in Length,	1½ inch Cutter		each	2.00
" 24	"	" 8	" 2	"	"	2.00
" 35	— Handle Smooth Plane,	9 inches in Length,	2 inch Cutter		"	2.50
" 36	"	" 10	" 2½	"	"	2.75
" 37	— Jerry	" 13	" 2½	"	"	3.00

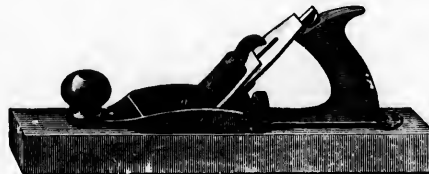

No. 26	— Jack Plane,	15 inches in Length,	2 inch Cutter		each	2.25
" 27	"	" 15	" 2½	"	"	2.50
" 29	— Fore	" 20	" 2½	"	"	2.75
" 30	— Jointer	" 22	" 2½	"	"	3.00
" 33	"	" 23	" 2½	"	"	3.25

One in a box.

IRON PLANES

STANLEY'S ADJUSTABLE CIRCULAR PLANE



No. 113—Adjustable Circular, $1\frac{1}{2}$ inch Cutter each \$4.00
 This Plane has a flexible Steel Face, which can be easily shaped to any required arc, either concave or convex, by turning the Knob on the front of the Plane.

ADJUSTABLE SCRAPER PLANE



This Tool is used for scraping and finishing Veneers or Cabinet-work. It can be used equally well as a Tooth Plane; and will do excellent work in scraping off old paint and glue.
 No. 112—Adjustable Scraper Plane, 9 inches, 3 inch Cutter each \$3.00

IMPROVED SCRUB PLANE



This Tool has a single Iron, with the cutting edge rounded. It is particularly adapted for roughing down work before using a Jack or other Plane.
 No. 40—Iron Stock, $9\frac{1}{2}$ inches in length, $1\frac{1}{2}$ inch Cutter each \$1.50

STANLEY'S ADJUSTABLE BEADING, RABBIT AND MATCHING PLANE



This Plane embraces (1) Beading and Center Beading Plane; (2) Rabbit and Filletter; (3) Dado; (4) Plow; (5) Matching Plane; (6) Sash Plane; and (7) a superior Slitting Plane. Each Plane has seven Beading Tools (1-8, $\frac{3}{16}$, $1\frac{1}{4}$, $\frac{5}{16}$, $\frac{3}{8}$, $\frac{7}{16}$ and $1\frac{1}{2}$ inch), ten Plow and Dado Bits (1-8, $\frac{3}{16}$, $1\frac{1}{4}$, $\frac{5}{16}$, $\frac{3}{8}$, $\frac{7}{16}$, $1\frac{1}{2}$, $\frac{5}{8}$, $\frac{3}{4}$ and $7\frac{1}{8}$ inch), a Slitting Blade, a Tonguing Tool and a Sash Tool.
 No. 45—Nickel-Plated, with Twenty Tools, Bits, etc. each \$12.00

HOLLOWS AND ROUNDS, FOR PLANE No. 45

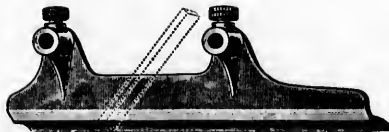

Nos.....	6	8	10	12	
Cutter.....	$\frac{3}{8}$	$\frac{1}{2}$	$\frac{5}{8}$	1 inch	wide.
Works.....	$\frac{3}{8}$	$\frac{1}{2}$	$1\frac{1}{2}$	1 1/2 "	circle.
Price.....	per pair \$2.10				2.10

NOSING TOOL, FOR PLANE No. 45

No. 5—Nosing Tool, $1\frac{1}{4}$ inch (attach same as above), each \$1.50

REEDING TOOLS, FOR PLANE No. 45

Additional Tools for Reeding, consisting of two, three, four or five Beads each will be furnished to order at prices given below. They can only be used with Plane No. 45.

Size of Beads, either 1-8, 3-16 or 1-4 inch—2 Beads, 30c.; 3 Beads, 45c.; 4 Beads, 60c.; 5 Beads, 75c. each.

One in a box.

each \$3.00
 " 3.25
 " 3.75
 " 3.75
 " 4.75
 " 5.50
 " 6.50

each 2.75
 " 3.50

each 2.00
 " 2.50
 " 2.50
 " 2.75
 " 3.00

each 2.25
 " 2.50
 " 2.75
 " 3.00
 " 3.25

PATENT FLOOR PLANE



This Tool will be found useful for planing Floors, Bowling Alleys, Skating Rinks, Decks of Vessels, etc. The construction of the Plane will enable the owner to do more work, and with less outlay of strength, than can be done with any other tool. The weight of the Plane is about 10 pounds, and the full length of the handle 45 inches.

No. 74—Floor Plane, 10½ inches in length, 2½ inch Cutter each \$8.75

BAILEY'S ADJUSTABLE VENEER SCRAPER



No. 12



No. 83

No. 12—Adjustable Veneer Scraper, 3 inch Cutter.....each \$3.50
 " 83—Wood Scraper, with Handles and Roller, 3 inch Blade..... " 1.00

WOODWORKER'S HANDY ROUTER PLANE

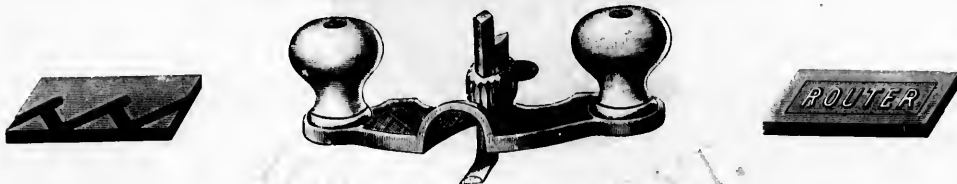

This Tool will smooth the bottom of grooves, panels, or all depressions below the general surface of any wood-work; and will rapidly router out mortises for Sash-frame Pulleys, etc.

No. 71—Nickel-Plated, with Steel Bits (¼ and ½ inch).....each \$2.25

STANLEY'S UNIVERSAL HAND BEADER

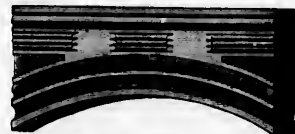
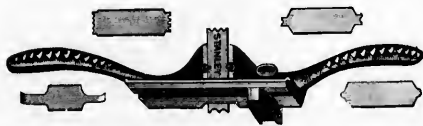

SAMPLE OF WORK DONE BY BEADER

For Beading, Reeding or Fluting, straight or irregular surfaces and for all kinds of light Routing. With a square gauge for straight, and an oval gauge for curved work.

Both ends of the Cutters are sharpened, thus embracing six ordinary sizes of Beads, four sets of Reeds, two Fluters, and a double Router Iron (¼ and ½ inch).

No. 66—Iron Stock, with seven Steel Cutters.....each \$1.50

One in a box.

SAW SETS

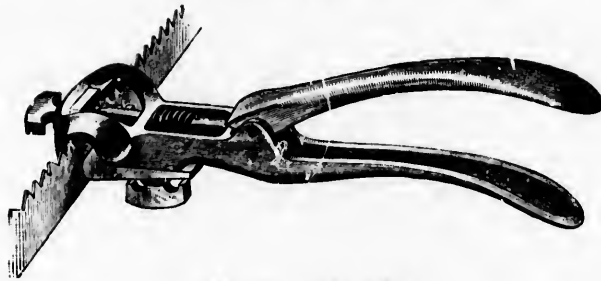

FOR HAND AND TENON SAWS

No. 1—Perfect, Polished per doz. \$5.85



FOR CROSS-CUT AND CIRCULAR SAWS

No. 3—Perfect, Japanned per doz. 11.65
 No. 1 packed one in a box. No. 3 half-dozen in a wood box.



No. 431



No. 432

No. 431—Bright, Forged Steel, Turn-screw Handle..... per doz. 4.60
 " 432— " " " " Varnished Wood Handle..... " 4.05
 One dozen in a box.



HAMMER SAW SETS

No. 771—Wynn's Hammer Saw Sets..... per doz. 7.10
 Half-dozen in a package.

SAW SETS

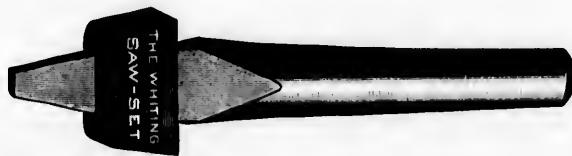

The Whiting, for Cross-Cut Sawsper doz. \$8.00

One in a box.



The Lincoln, for Cross-Cut Sawsper doz. 9.00

One in a box.

THE CONQUEROR SWAGE, JUMPER OR UPSET

No. 1



No. 2

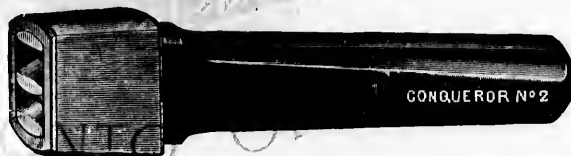

No. 3



- | | Each |
|--|--------|
| No. 1—For large Circular Saws, as per cut. | \$1.20 |
| “ 2—For small Circular and Mill Saws.. | 3.00 |
| “ 3—For Band Saws and small Circular Saws..... | 3.00 |

One in a box.

The lower opening in the Swage being rounding on the bottom, takes its bearing on the centre of the tooth, spreading and shaping it as shown on section of tooth *H*. The upper opening (in which section of tooth is inserted) is used for squaring up, and leaves the tooth as shown at *G*.

The teeth of a saw require to be swaged to a sharp, keen edge, and the bottom of the openings in the Conqueror being slotted it is impossible to blunt or injure the fine cutting edge of the tooth, which is frequently done by other swages. One of the principal drawbacks in the manufacture of solid swages has been the difficulty experienced in properly hardening them at the bottom of the opening, which portion of swage does all the work, and requires to be hardened in the most perfect manner.

The Conqueror is hardened before the sleeve is driven on, and the hardening composition passes freely through the slots at the bottom of the openings, thus insuring an even and correct hardening in that portion of the swage where it is most required.

SAW GAUGES AND JOINTERS

CHAMPION SAW GAUGE AND JOINTER

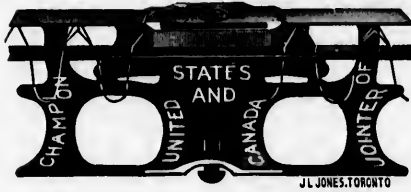

THE "CHAMPION" SAW GAUGE AS A DRAG TOOTH JOINTER.

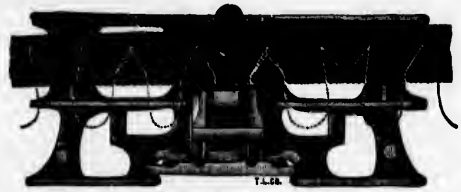

THE "CHAMPION" COMBINED SAW GAUGE AND JOINTER AS A SIDE-FILER.

Champion Combination Saw Gauge, Jointer and Side Filer.....per doz. \$3.00

One dozen in a box.

EUREKA SAW TOOLS

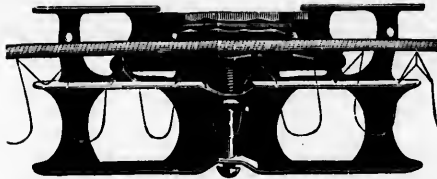

JOINTER



RAKER TOOTH GAUGE



SETTING BLOCK



TOOTH SET GAUGE

Eureka Combination Saw Tools, comprising a combined Saw Filer, Jointer and Raker Tooth Gauge, Setting Block and Tooth Set Gauge. One set in a box.....per doz. sets \$10.00

Eureka Saw Jointers. One dozen in a box.....per doz. 3.00

SAW GAUGES AND GUMMERS



GAUGE FOR REGULATING CLEANING TEETH

No. 15—Saw Gauges, Hardened Steel..... per doz. \$0.00

The cleaning teeth of all saws should be somewhat shorter than the cutting teeth, and although shorter should be a uniform length throughout. With the use of this Gauge the teeth can be rapidly and correctly reduced to an even length.

NEW DOMINION SAW GUMMERS

RICE LEWIS & SON
LIMITED



- No. 0—For Cross Cut Saws, complete with one cutter grinder, one crank, one set of boxes and one cutter, $\frac{3}{8}$ and $\frac{1}{2}$ inch.....each \$8.00
- " 1—For Circular Saws, complete with two cutter grinders, two cranks, two sets of boxes, and one cutter, $\frac{3}{8}$, $\frac{1}{2}$, $\frac{3}{4}$ and $\frac{1}{2}$ inch.....each 12.00
- " 2—For Circular Saws, complete with three cutter grinders, three cranks, three sets of boxes, one arbor and one cutter, $\frac{3}{8}$, $\frac{1}{2}$, $\frac{3}{4}$, $\frac{1}{2}$ and 1 inch.....each 16.00

SAW GUMMER CUTTERS



SOLID

Size.....	1/4	5/16	3/8	1/2	5/8	3/4	7/8	1 inch.
Per dozen.....	\$0.00	0.60	0.60	0.60	9.00	13.20	16.50	19.80

HOLLOW CUTTERS TO RUN ON ARBOR FOR NEW DOMINION GUMMERS

Size.....	3/4	7/8	1	1 1/8	1 1/4	1 1/2 inch.
Per dozen.....	\$8.00	9.15	10.00	12.00	13.25	14.60

TOOL CHESTS

Superior quality of Tools, selected from our own Stock.



- No. 1—Contains 10 inch Hand Saw, 8 inch Brace, $\frac{1}{8}$ and $\frac{1}{4}$ Bits, Hammer, Screw Driver, 2 foot Rule, Steel Square, Block Plane, Mallet, $\frac{1}{2}$ inch Chisel and Handle, Bracket Saw and 4 Blades, Brad Awl, Oil Stone, Oil Can, and Carpenter's Pencil. Complete in Chest 23x10x10 inch, with Lock and Key each \$3.00
- " 2—Contains 23 inch Hand Saw, 8 inch Brace, $\frac{1}{8}$ and $\frac{1}{4}$ Bits, Hammer, Screw Driver, 2 foot Rule, Steel Square, Block Plane, Mallet, 10 inch Wrench, $\frac{1}{8}$ and $\frac{3}{8}$ Chisel and Handles, $\frac{3}{4}$ Gouge and Handle, 6 inch Dividers, 2 inch Spokeshave, 4 inch Saw File, Bracket Saw and 4 Blades, Oil Stone, Oil Can, Brad Awl, Carpenter's Pencil, Bottle of Glue, and 3 sheets Sand Paper. Complete, in Chest 20x12x12 inch, with Lock and Key each 6.00
- " 3—Contains 23 inch Hand Saw, 23 inch Rip Saw, 8 inch Brace, $\frac{1}{8}$, $\frac{1}{4}$ and $\frac{3}{8}$ Bits, Hammer, Mallet, Screw Driver, 2 foot Rule, Steel Square, Block Plane, 10 inch Wrench, $\frac{1}{8}$, $\frac{1}{2}$ and $\frac{3}{4}$ inch Chisels and Handles, $\frac{3}{4}$ Gouge and Handle, pair 6 inch Dividers, 2 inch Spokeshave, Saw File and Handle, Bracket Saw and 4 Blades, Oil Stone, Oil Can, Brad Awl, Gimlet, Hand Vice, Sliding T Bevel, pair Carpenter's Pincers, 24 inch Clamps, Level, Marking Gauge, Nail Set, Tin of Glue, 6 sheets Sand Paper, and Carpenter's Lead Pencil. Complete, in Chest 20x12x12 inch, with Lock and Key each 9.00
- " 4—Contains 23 inch Hand Saw, 23 inch Rip Saw, 10 inch Brace, $\frac{1}{8}$, $\frac{1}{4}$, $\frac{1}{2}$ and $\frac{3}{4}$ Bits, Countersink Bit, 2 Screw Drivers, 2 foot Rule, Steel Square, Hammer, Mallet, Iron Block Plane, Wood Jack Plane, Drawknife, 2 4-inch Clamps, 10 inch Wrench, Marking Gauge, Sliding T Bevel, Spirit Level, Carpenter's Pincers, $\frac{1}{4}$, $\frac{1}{2}$ and $\frac{3}{4}$ inch Chisels and Handles, $\frac{1}{8}$ and $\frac{1}{2}$ inch Gouge and Handles, Hand Vice, Spokeshave, Bracket Saw and 4 Blades, 6 inch Dividers, Oil Can, Oil Stone, Brad Awl, Carpenter's Pencil, Gimlet, Saw File and Handle, 8 inch Flat File and Handle, Soldering Iron, Tin of Glue, and 12 sheets of Sand Paper. Complete, in Chest 20x12x12 inch, with Lock and Key each 12.00

TOOL CHESTS

Superior quality of Tools, selected from our own stock.



- Steel
Stone,
each \$3.60
- Steel
Handle,
Can,
12x12
each 6.00
- Screw
Handles,
and
Cutter's
and
each 9.00
- Bit,
Plane,
Level,
Vice,
Cutter's
and
each 12.00
- No. 5—Contains 24 inch Hand Saw, 26 inch Rip Saw, 8 inch Compass Saw, 10 inch Brace, $\frac{1}{8}$, $\frac{1}{4}$, $\frac{3}{8}$ and $\frac{1}{2}$ inch Brace Bits, Countersink and Turn Screw Bit, 2 Screw Drivers, 2 ft. Rule, Steel Square, Hammer, Mallet, 10 inch Wrench, pair 6 inch Pincers, pair 6 inch Dividers, Try Square, Sliding T Bevel, Steel Square, Wood Smooth and Jack Planes, Draw Knife, $\frac{1}{4}$, $\frac{1}{2}$ and $\frac{3}{4}$ inch Chisels and Handles, $\frac{1}{8}$ and $\frac{1}{4}$ inch Gouge and Handles, Spokeshave, Marking Gauge, Spirit Level, Hand Vice, 2, 4-inch Clamps, 2 Brad Awls, Gimlet, Hatchet, Bracket Saw with 4 Blades, 5 inch Saw File and Handle, 8 inch Flat File and Handle, 8 inch Cabinet Rasp, Oil Stone, Oil Can, Nail Set, 5 inch Plyers, Glass Cutter, Tin of Glue, and 12 sheets of Sand Paper. Complete in Chest, 33x16x16 inch, with Handles, Lock and Key...each \$18.00
- No. 6—Contains 24 inch Hand Saw, 20 inch Rip Saw, 8 inch Back Saw, 12 inch Compass Saw, 10 inch Brace $\frac{1}{8}$, $\frac{1}{4}$, $\frac{3}{8}$ and $\frac{1}{2}$ inch Brace Bits, Countersink and Turn Screw Bits, 3 Screw Drivers, 3, 5 and 6 inch, 2 Hammers, Mallet, 2 ft. Rule, Steel Square, Sliding T Bevel, Level, Wood Smooth and Jack Planes, Draw Knife, 10 inch Wrench, Spokeshave, Marking Gauge, pair 6 inch Dividers, pair 6 inch Carpenter's Pincers, $\frac{1}{4}$, $\frac{1}{2}$, $\frac{3}{4}$ and 1 inch Chisel and Handles, $\frac{1}{8}$ and $\frac{1}{4}$ inch Gouge and Handle, 2 Brad Awls, Gimlet, Hatchet, Bracket Saw and 4 Blades, Oil Can, Oil Stone, Bench Vice, Cabinet Rasp and Handle, Saw File and Handle, 8 inch Flat File and Handle, pair 5 inch Plyers, Tack Claw Glass Cutter, Soldering Iron, Bench Screw, Nail Set, Tin of Glue, 2, 4-inch Clamps, 12 sheets Sand Paper, Carpenter's Lead Pencil. Complete in Chest, 33x16x16 inch, with Handles, Lock and Key.....each 24.00
- No. 7—Contains 24 inch Hand Saw, 20 inch Rip Saw, 12 inch Compass Saw, 8 inch Back Saw, 10 inch Brace, $\frac{1}{8}$, $\frac{1}{4}$, $\frac{3}{8}$, $\frac{1}{2}$, $\frac{3}{4}$ and 1 inch Brace Bit, Countersink and Turn Screw Bits, 2 Screw Drivers, 4 and 6 inch, 2 Hammers, Mallet, 2 ft. Rule, Steel Square, Try Square, Sliding T Bevel, Level, Wood Smooth and Jack Plane, Draw Knife, Spokeshave, 10 inch Wrench, 2, 4-inch Clamps, Bench Screw, Bench Vice, $\frac{1}{4}$, $\frac{1}{2}$, $\frac{3}{4}$ and 1 inch Socket Chisel and Handles, $\frac{1}{8}$ and $\frac{1}{4}$ inch Gouge and Handles, Hatchet, pair 6 inch Pincers, pair 6 inch Dividers, pair 6 inch Combination Plyers, 2 Brad Awls, Gimlet, Oil Can, Oil Stone, Marking Gauge, Bracket Saw and 4 Blades, Cabinet File, Saw File, Flat File with Handles, Nail Set, Soldering Iron, Glass Cutter, Tack Claw, Tin of Glue, 12 sheets Sand Paper, Carpenter's Lead Pencil. Complete in Chest, 33x16x16 inch, with Handles, Lock and Key.....each 30.00

The chests for Sets Nos. 5 to 7 have drop front, with separate compartment for Saws and two Trays.

OLMSTED'S IMPROVED MITRE BOXES

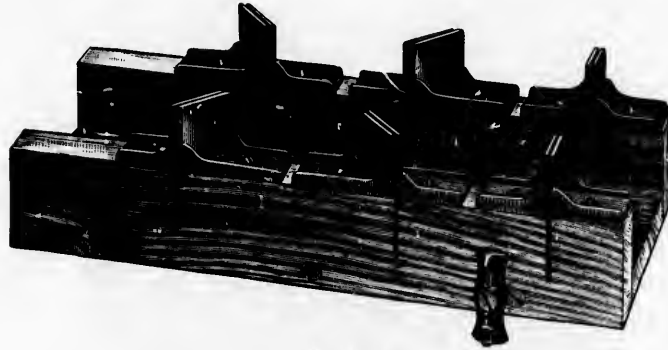

Nos. 3 and 4

The frame is made of hardwood, 1 inch thick. The irons are made sufficiently high and broad to make a good bearing upon the saw blade, and spaced sufficient to allow the saw to move freely.

No. 3—Will saw moulding $1\frac{1}{2} \times 3$ inches	each	\$2.00
" 4— " " $2\frac{1}{2} \times 4$ "	"	2.85

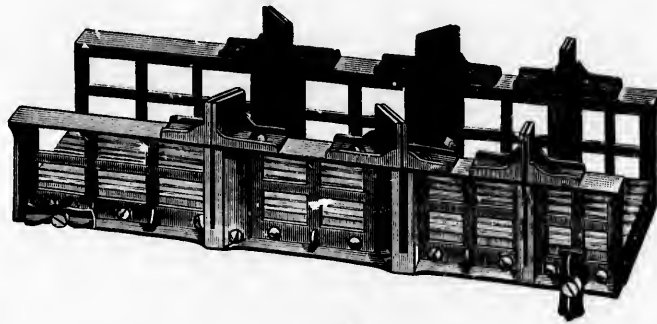

No. 5

The frame of this Box is made of iron, a thin board being fastened to the bottom as a strike.

No. 5—Will saw moulding $2\frac{1}{2} \times 4$ inches	each	6.00
--	------	------

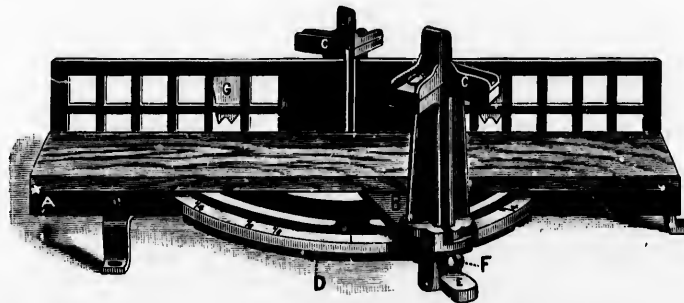

No. 6

Adjustable saw guides and notches, with device for holding work fast while sawing.

No. 6—Will take work 4 inches wide at mitre and 6 inches wide at right-angles.....	each	8.10
--	------	------

LANGDON ADJUSTABLE MITRE BOX

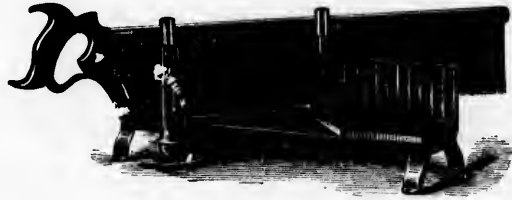

THE NEW LANGDON MITRE BOX

No. 17—With Saw for Wood, 18 x 4.....	each	\$13.00
“ 18— “ “ 20 x 4.....	“	14.00
“ 19— “ “ 22 x 4.....	“	14.80

ADJUSTABLE JOINTER GAUGE



Adjustable for squaring or to any level desired, attach with the depression in centre of the wing opposite the cutting edge of the plane iron.....each 2.55

IMPROVED UNIVERSAL TRIMMER

RAZOR

CUT

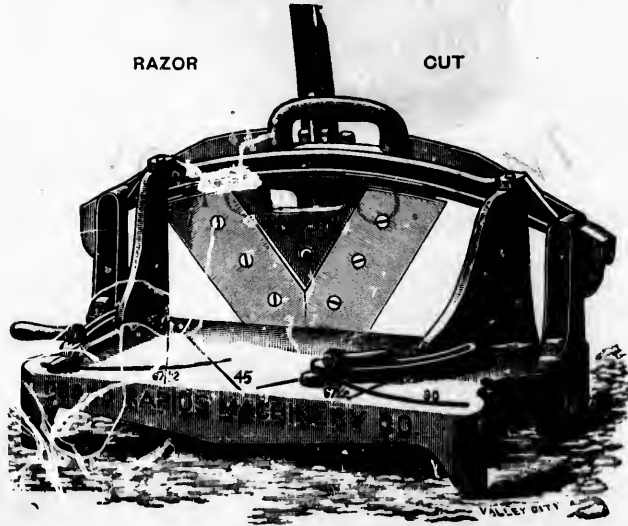

Circular ways for the knife to travel in, giving a draw as well as a shearing cut.

No. 8—Cuts 4½ in. wide and 8 in. long, weight 50 lbs.....	each	41.80
---	------	-------

HACK SAWS

STUB'S HACK SAWS



Wrought Iron Frame.

Size	5	6	7	8	9	10	12 inch.
Each	\$1.40	1.65	1.85	2.10	2.40	2.60	3.05

GRIFFIN HACK SAWS



Malleable Iron Frame.

Size	8	9	10	12 inch.
No. 30—Japanned Frame, with 12 blades	per doz. \$18.00	10.15	20.25	22.50



No. 31—Japanned Frame, with 12 blades, 8 inch.....	per doz.	\$22.50
" 35—Nickel-Plated " " 12 " 8 "	"	30.40



No. 3—Coppered Steel Frame, with one blade, 0 inch	per doz.	5.00
--	----------	------

THOMPSON'S HACK SAWS



Extension Frame.

No. 40—Nickel Steel Frame, extending 8 to 12 inches, with one blade	per doz.	18.00
---	----------	-------

HACK SAWS

THE "UNIVERSAL" ADJUSTABLE SAW FRAME



No. 42—Adjustable Frame, without Bladesper doz. \$17.15

12 inch.
3.05

RAILROAD TRACK HACK SAW FRAME



No. 2—Adjustable Frame, with two Handles, without Blades each 3.35

This Frame has been designed for use in cutting electric railway rails, iron girders, beams, etc. It is made of steel, and is very strong. It is 7½ inches deep and adjustable for saws 10 to 14 inches long.

12 inch.
22.50

HACK SAW BLADES



Size	5	6	7	8	9	10	12 inch.
Stubs	per doz. \$1.05	1.85	2.35	2.85	3.25	3.75	4.05
Griffin	per gross	11.55	12.40	13.20	14.00
Thompson	"	0.25	10.00	11.00	11.80	12.00	15.25
Star	"	13.20	14.10	17.15	21.15

The Stubs Hack Saw Blades are steel, tempered, 12 teeth to the inch. The Griffin and Thompson are flexible back, hardened teeth—REGULAR 14 teeth, and FINE 23 teeth to the inch. The Star are full hardened—REGULAR 14 teeth, FINE 23 teeth to the inch. Regular teeth supplied unless otherwise ordered.

"UNIVERSAL" HACK SAW BLADES



The illustration on the left will point out the fact that every tooth is "set" either narrower or wider than its predecessor, allowing the Saw to cut more smoothly, faster, and last longer than saws of the ordinary set.

Size	8	9	10	12	14 inch.
Per gross	\$11.70	12.00	15.30	18.00	22.50

The 14 inch Saws are ¾ inch wide, 10 teeth; 12 inch, ⅝ inch wide, 13 teeth; others, ½ inch wide, 16 teeth. All are 24 gauge.

doz. 18.00

SCROLL SAWS AND LATHES



PRIZE HOLLY SAW, No. 1



PRIZE DEMAS SAW AND LATHE, No. 10

- No. 1—Prize Holly Scroll Saw complete, with Polished Tilting Table, Emery Wheel, Power Drill, 12 Saw Blades, 1 Drill Point and 12 Designs.....each \$4.50
- " 10—Prize Demas Saw and Lathe complete, with Polished Tilting Table, Emery Wheel, Power Drill, 12 Saw Blades, 3 Drill Points, 30 Patterns and 5 Turning Tools.....each 12.00
- Saw Clamps for Prize Holly and Prize Demas Saws.....per pair 0.35

NEW ROGERS' SCROLL SAW



NEW ROGERS' SAW, Nos. 1 and 2

No. 1

Consists of Scroll Saw, with Japanned Tilting Table, Iron Balance Wheel instead of Emery (as per cut), Power Drill, Pratt's Rubber Positive Blower, 12 Saw Blades, Wrench, Sheet of Designs and 3 Drill Points. Each machine is set up and run and carefully inspected before leaving the works. They are shipped in close boxes. Weight, boxed, 42 lbs.

No. 1—Rogers' Saw.....each \$6.00

No. 2

Consists of Scroll Saw with Nickel-Plated Tilting Table, Emery Wheel, Power Drill, Pratt's Rubber Positive Blower, 12 Saw Blades, Wrench, Sheet of Designs, and 3 Drill Points. Each machine is set up and run and carefully inspected before leaving the works. It is then taken down and shipped in close boxes. Weight, boxed, 42 lbs.

No. 2—Rogers' Saw.....each \$7.00

Saw Clamps, for Rogers', Goodell or Companion Saws.....per pair 0.40

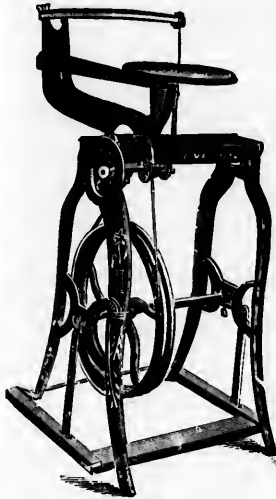

NO. 5 DEMAS

IMPROVED DEMAS SAW, NO. 5

Height of Saw Table from floor, 43 inches; height to top of Bed, 36 inches; diameter of Drive Wheel, 21 inches; weight of Drive Wheel, 46 lbs; weight of machine, 110 lbs. A plank 2½ inches thick and 24 inches long or wide can pass under arm and back of Saw Blade.

THE BUZZ SAW AND MOULDING ATTACHMENTS

(For Prices see page 109.)

May be propelled by the same treadle and wheel power, as the Scroll Saw attachment shown in cut and can be easily removed.

No. 5—Demas Saw.....each \$19.80

PRICE LEWIS & SON
HAND BRACKET SETS



No. 2

These sets are packed in paper boxes, and embrace a Spring Steel Saw Frame, polished and nickel-plated, 5 x 12 inches, having patent Clamps for holding the Saw Blades, rosewood handle. Three sheet designs, embracing a great variety of fancy and useful articles; twelve Saw Blades, one Awl, one sheet of Impression Paper, and full directions for using the Saw.

No. 2.....per doz. \$18.75

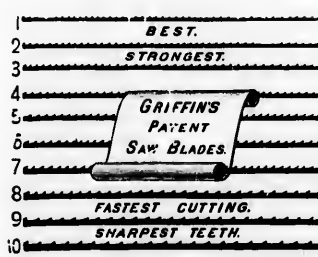

TORONTO, ONT.

SAW BLADES

Nos.	00 to 6	7	8	9	10
Griffin	per gross \$1.15	1.25	1.35	1.45	1.00
Boker's	" 0.00	1.00	1.10	1.20	1.25

One gross in a package.

FOR DEMAS SAW, NO. 5

7½ inches long.

No.	A	B	C	D	E	F
Size	1/8	3/8	1/2	5/8	3/4	7/8
Per dozen	\$1.25	1.25	2.55	2.55	2.55	2.55

MANUAL AND PATTERNS

This is a book of 87 full-size Patterns. It also contains full instructions in Fret Sawing, giving descriptions of all the woods and their uses; it also has a treatise on gluing, shellacing, polishing, sand-papering, etc.

Price of Manual and Patterns.....each \$0.75

GOODELL LATHE AND SAW ATTACHMENT

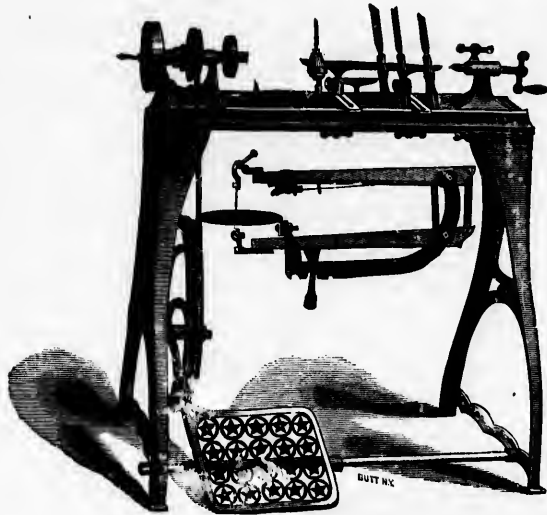

This Lathe is provided with a Long and Short Tool Rest, 5 Turning Tools, one $4\frac{1}{2} \times \frac{3}{4}$ Emery Wheel, Wrench and 6 Drill Points. The swing of Lathe is 5 inches, length of bed 24 inches, distance between centres $13\frac{1}{2}$ inches.

The Lathe Head is provided with a 2 inch Face Plate, a Spur and Screw Centres, Drill Chuck suitable for Drills to $\frac{1}{2}$ inch.

THE SCROLL SAWING ATTACHMENT

As seen in the cut, is secured to the Lathe Bed by one bolt and can be easily attached or removed.

Finely finished, Planed and Polished Parts Nickel-Plated.

No. 7—Price of Lathe and Lathe Tools only.....\$17.00

No. 8—Price of Lathe and Lathe Tools, with Scroll Saw Attachment ... 20.40

In ordering please state if Lathe only or Lathe with Scroll Saw Attachment is wanted.

COMPANION LATHE AND SAW ATTACHMENT

This Companion Lathe and Scroll Sawing Attachment was specially designed for the *Youths' Companion*.

It is similar to the "Goodell," only the polished parts are not plated. The Lathe Bed is 24 inches long, $13\frac{1}{2}$ inches between centres, 5 inch Swing supplied with 3 Turning Tools, Emery Wheel, Screw Driver, Wrench and 6 Drill Points.

The Scroll Sawing Attachment is secured to the Lathe Bed by one bolt and can be easily attached or removed.

No. 11—Price of Lathe and Tools only \$11.90

No. 13—Price of Lathe, Tools and Scroll Saw Attachment..... 14.50

In ordering please state if Lathe only or Scroll Saw Attachment is wanted.



DEMAS LATHE NO. 4



No 4 DEMAS LATHE

Length of Bed 42 inches, with Planed Ways, height from floor 34 inches, swing 5 inches.
Distance between centres 30 inches, Adjustable Lathe Rest and Tail Block, weight 130 lbs.

No. 4—Demas Turning Lathe, without Tools	each \$24.75
Scroll Saw Attachment as with No. 5 Demas Saw to fit No. 4 Lathe	" 8.25

DOVETAIL, BUZZ SAW AND MOULDING ATTACHMENTS

For Demas No. 4 Lathe or Demas No. 5 Saw.

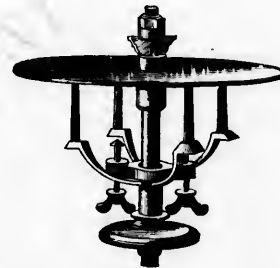
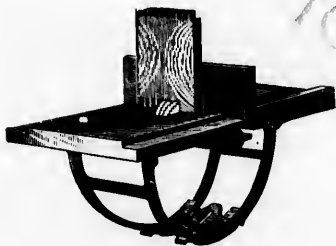

Dovetailing Attachment, suitable for No. 4 Lathe only. Each, with 4 Saws..... \$16.50	Buzz Saw Attachment, with 6 inch Saw. For No. 4 Lathe.....each \$ 8.25 " " 5 Saw..... " 11.55	Moulding Attachment, suitable for No. 4 Lathe or No. 5 Saw. Each (no knives) \$16.50 Moulding Knives, per set 3.30
--	---	--

In ordering Buzz and Dovetailing Attachment separately, state name of your machine and if it has a Lathe Attachment.

CIRCULAR SAWS

SILVER STEEL

Patent Machine Ground, of Extra Quality and Superior Workmanship.

DIAMETER. Inches.	Gauge.	Size of Hole. Inches.	Price Each.	Each Gauge Extra.	DIAMETER. Inches.	Gauge.	Size of Hole. Inches.	Price Each.	Each Gauge Extra.
4	19	$\frac{3}{8}$	\$0.75	\$0.06	36	0	$1\frac{1}{2}$	\$21.00	\$1.50
5	19	$\frac{3}{8}$	1.00	0.08	38	8	$1\frac{1}{2}$	24.20	1.75
6	18	$\frac{3}{8}$	1.15	0.10	40	8	$1\frac{1}{2}$	26.40	2.25
7	18	$\frac{3}{8}$	1.40	0.12	42	8	$1\frac{1}{2}$	34.65	2.75
8	17	$\frac{3}{8}$	1.08	0.14	44	8	$1\frac{1}{2}$	42.00	3.20
9	16	1	1.95	0.16	46	8	$1\frac{1}{2}$	49.25	3.75
10	15	1	2.25	0.18	48	7	2	57.75	4.50
12	15	1	2.85	0.20	50	7	2	65.65	4.75
14	14	1	3.50	0.24	52	6	2	76.00	6.30
16	14	$1\frac{1}{8}$	4.40	0.30	54	6	2	80.75	7.50
18	13	$1\frac{1}{8}$	5.30	0.45	56	6	2	107.50	9.00
20	13	$1\frac{1}{8}$	6.30	0.48	58	6	2	120.50	10.00
22	12	$1\frac{1}{8}$	7.40	0.52	60	6	2	130.00	12.00
24	11	$1\frac{1}{8}$	8.60	0.60	62	6	2	162.75	13.50
26	11	$1\frac{1}{8}$	9.90	0.70	64	6	$2\frac{1}{2}$	180.00	15.75
28	10	$1\frac{1}{8}$	12.00	0.80	66	6	$2\frac{1}{2}$	200.00	18.00
30	10	$1\frac{1}{8}$	14.00	0.90	68	6	$2\frac{1}{2}$	220.00	20.00
32	10	$1\frac{1}{8}$	16.50	1.00	70	6	$2\frac{1}{2}$	252.00	22.50
34	9	$1\frac{1}{8}$	18.70	1.20	72	6	$2\frac{1}{2}$	284.00	25.00

PERIN'S FRENCH BAND SAW BLADES

SOLE AGENTS

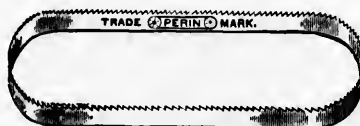

FOR CANADA

These Blades are joined, set and filed, ready for use, and stamped with M. Perin's name and Trade Mark. They are highly finished, even in temper, and the backs rounded and polished.

LENGTH.	WIDTH IN INCHES.											
	$\frac{3}{8}$	$\frac{7}{16}$	$\frac{1}{4}$	$\frac{5}{16}$	$\frac{3}{8}$	$\frac{7}{16}$	$\frac{1}{2}$	$\frac{5}{8}$	1	$1\frac{1}{4}$	$1\frac{1}{2}$	2
17 feet	\$3.25	\$3.25	\$3.00	\$3.90	\$4.35	\$4.85	\$5.20	\$6.30	\$7.15
17 " 10 in.	3.40	3.40	3.75	4.15	4.60	5.05	5.40	6.60	7.45
18 " 8 in.	3.55	3.55	4.00	4.40	4.75	5.90	5.65	6.85	7.80
20 " 6 in.	3.90	3.90	4.30	4.70	5.15	5.75	6.15	7.45	8.45	12.30

BAND SAW BLADES SET AND FILED, BUT NOT JOINED

Size	$\frac{1}{8}$	$\frac{3}{16}$	$\frac{1}{4}$	$\frac{5}{16}$	$\frac{3}{8}$	$\frac{7}{16}$	$\frac{1}{2}$	$\frac{5}{8}$	1	$1\frac{1}{4}$	inch.
Per 100 feet	\$15.40				17.50	19.00	21.70	24.50	28.00	33.50	

BAND RE-SAWS

Size	2	$2\frac{1}{4}$	$2\frac{1}{2}$	3	inch.
Per 100 feet

Band Saw Blades, $\frac{1}{8}$ inch are 20 gauge; $\frac{3}{16}$ to 2 inch, 21 gauge; Re-Saw Blades, 18 gauge, with teeth $1\frac{1}{2}$ inch apart.

SILVER SOLDER

Silver Solder, rolled thin, in ounce rolls.....per ounce \$1.50

The successful brazing of Band Saws largely depends on the Solder used. We keep constantly in stock special Silver Solder that has proven to be the best adapted for brazing tempered steel.

PIT, WHIP AND ICE SAWS

EXTRA TEMPERED



PIT SAWS

Complete with Tiller and Box.

Length.....	5	5½	6	6½	7	7½	8 feet.
10½ inch Butt..... each	\$0.00	0.40	0.80	7.20	7.00	8.00	8.50

WHIP SAWS

Complete with Tiller and Box.

Length.....	5	5½	6	6½	7	7½	8 feet.
6 inch Butt, Tapering to 3 inches at Point..... each	\$4.00	4.50	5.00	5.50	6.00	6.50	7.00
7 " " " 3 " " " " " " " " " " " "	4.20	4.70	5.20	5.70	6.20	6.70	7.20
8 " " " 4 " " " " " " " " " " " "	4.40	4.90	5.40	5.90	6.40	6.90	7.40

SPECIAL KLONDIKE WHIP SAWS

Complete with Tiller and Box.

Length.....	6	6½ feet.
8 inch Butt, Tapering to 4 inches at Point..... each	\$5.40	5.90

EXTRA CAST STEEL ICE SAWS

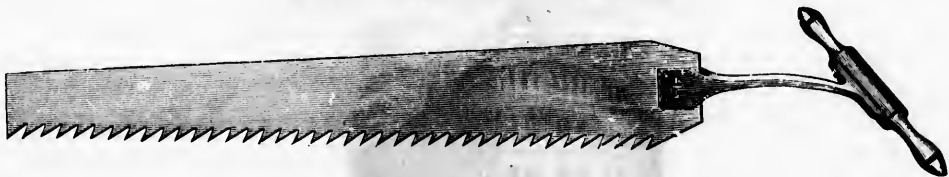

With Tiller Handle.

7 inch Butt, Tapering to 5 inches at Point, 12 and 13G, Set and Sharpened, without Handle..... per foot	\$1.00
8 " " " 6 " " " 12 " 13G " " " " " " " " " " " "	1.05

PIT AND ICE SAW HANDLES

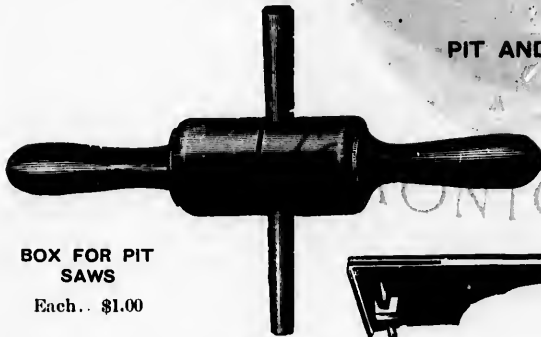

TILLER FOR PIT AND ICE SAWS

Each..... \$1.25

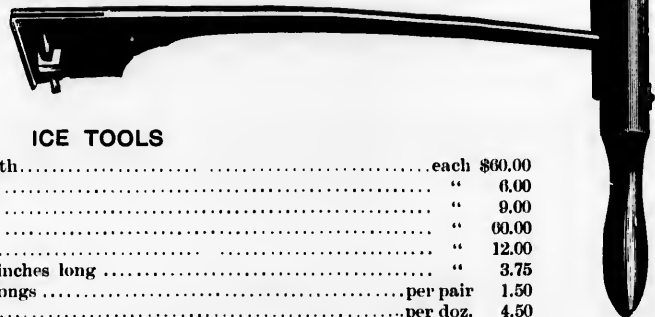

BOX FOR PIT SAWS

Each.. \$1.00

ICE TOOLS

Ice Plows, 12 inch, with Cast Steel Teeth..... each	\$60.00
Stationary Guides for Plow, extra..... "	6.00
Swing Guides, " " " " " " " " " " " "	9.00
One Horse Markers..... "	60.00
One Horse Scrapers..... "	12.00
Two Prong Splitting Chisels, 4 feet 6 inches long..... "	3.75
24 inch, Iron Handled, Steel Pointed Tong..... per pair	1.50
5 foot Pike Poles..... per doz.	4.50

CROSS-CUT SAWS

LANCE TOOTH



The Queen, ground extra thin on the back, set and filedper foot \$1.00



The Victor, ground thin on the back, set and filedper foot 0.75

No
Pr
No
"



No

CROSS-CUT SAWS

LANCE TOOTH

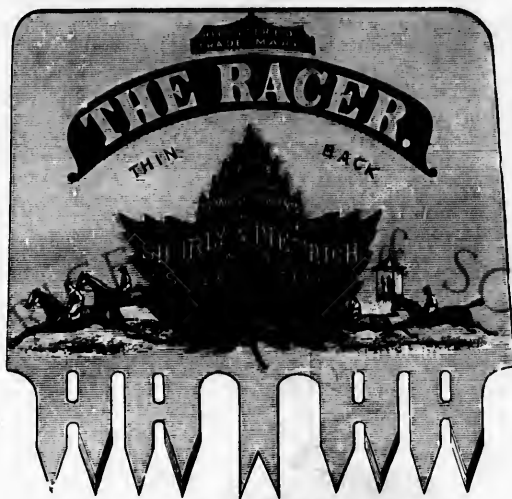

SHURLY & DIETRICH

No. 0—Racer, ground extra thin on the back, set and filed.....	per foot	\$1.00
Premier, ground thin on the back, set and filed.....	"	0.95
No. 1—Lance Tooth, Maple Leaf, ground thin on the back, set and filed.....	"	0.95
" 3— " " ground thin on the back	"	0.60

THE NARROW RACER

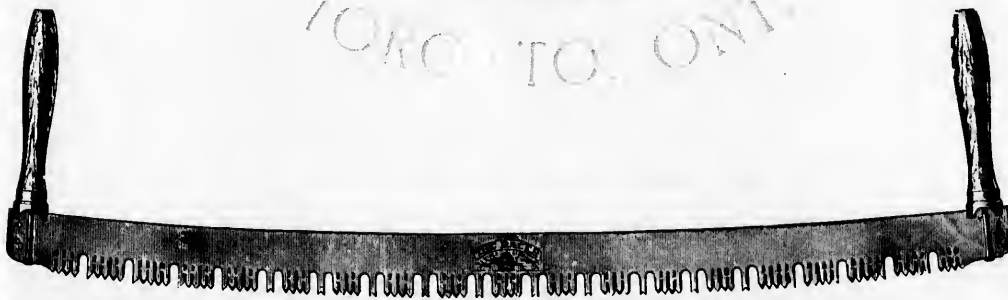

NARROW RACER, FOR SAWING LOGS OR TREES

Narrow Racer, Silver Steel, set and filed	per foot	\$0.75
---	----------	--------

CROSS-CUT SAWS

IMPROVED CHAMPION



Improved Champion, Silver Steel, set and filed	per foot	\$0.00
" " Cast Steel " "	"	0.55

TUTTLE TOOTH



Tuttle Tooth, Silver Steel, set and filed	per foot	\$0.90
" " Cast Steel, " "	"	0.55
Disston's Tuttle Tooth, four gauges thinner on back than on teeth	"	0.60
" " " two " " " " " "	"	0.54

Toothed to the end for Pacific Coast Trade.

CROSS-CUT SAWS AND HANDLES



BOYNTON



No. 5

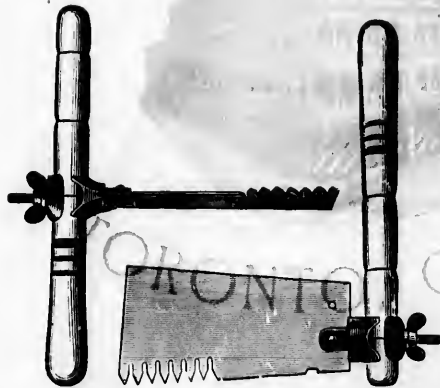

No. 6

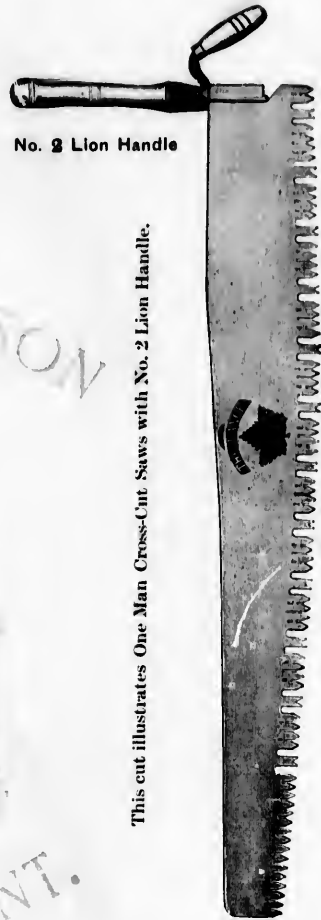

No. 2 Lion Handle

This cut illustrates One Man Cross-Cut Saws with No. 2 Lion Handle.

CROSS-CUT SAW HANDLES

No. 1—Boynton	per dozen pairs	\$2.25
" 3—Malleable Iron Loop (similar to No. 1)....	" "	2.25
" 5— " "	" "	2.25
" 6—Adjustable	" "	2.25
" 2—Lion, for One Man Saws	" "	6.50
Handles Painted Red	per dozen pairs extra, net	0.20

ONE MAN CROSS-CUT SAWS

LANCE TOOTH

Sold by the foot, price without Handles,
Set and Filed ready for use.

No. 1—Maple Leaf	per foot	\$0.95
" 3—Lance Tooth.....	" "	0.60

per foot \$0.90
" 0.55

foot \$0.90
0.55
0.60
0.54

WOOD SAWS

FRAMED

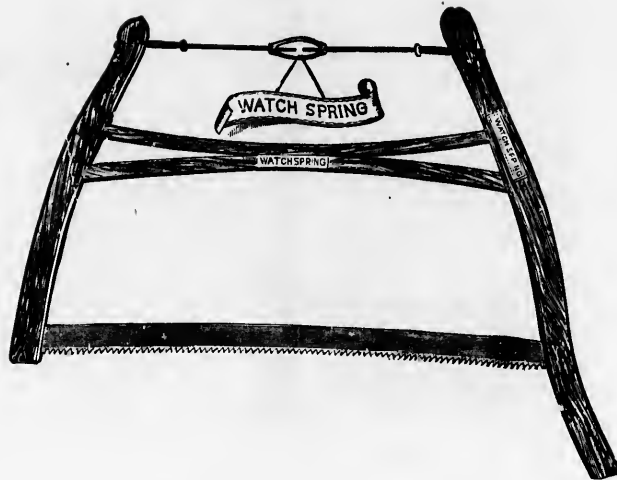

Watch Spring, Painted Frames, Blued Spring Steel Blades per doz. \$5.50

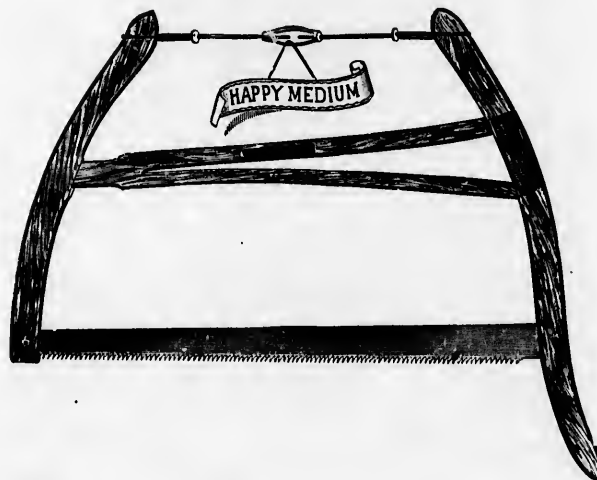

Happy Medium, Painted Frames, Tapered Blades per doz. 5.80

Half-dozen in a box.

WOOD SAWS

FRAMED

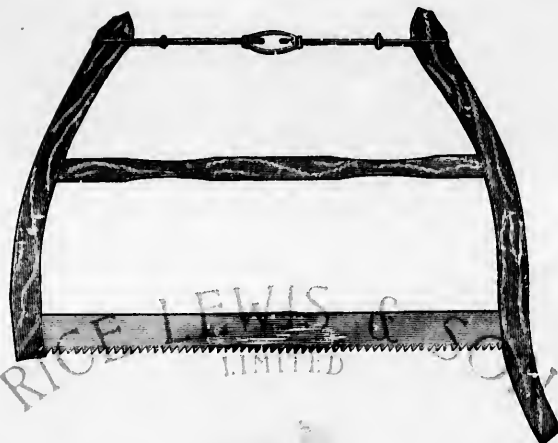

No. 5—Plain Frames, 30 x 2 inch Blade.....	per doz.	\$4.15
" 7—Painted " 30 x 2 " "	" "	4.50
" 5—Frames only, Plain.....	" "	1.90
" 7— " " Painted.....	" "	2.25

doz. \$5.50

SAW BUCKS

Folding Saw Bucks, Hardwood, Plain.....	per doz.	4.15
" " " " Painted.....	" "	6.00

SAW RODS



No. 11—21 inches long.....	per doz.	1.00
----------------------------	----------	------

SAW SCREWS

WROUGHT BRASS



No. 1C



No. 2C



No. 4C



No. 1S

Full size cuts.

Nos.....	1C	2C	4C	1S	2S
Per gross.....	\$5.15	6.00	10.35	4.50	5.00

doz. 5.90

STEEL SAW SCREWS—BRIGHT

No. 3—Raised Round Heads, style similar to No. 2 C.....	per gross	8.00
---	-----------	------

HAND, PANEL AND RIP SAWS



A. R. PERRY & BRO. No. 10

Size	16	18	20	22	24	26 inch.
No. 10—Cast Steel Hand Saws..... per doz.	\$5.00	6.00	6.10	6.20	6.40	6.50
" 10— " Rip Saws..... "	"	"	"	"	"	6.50



ENTERPRISE. No. 25

No. 25—Cast Steel Hand or Rip Saws, 26 inch per doz. \$10.25

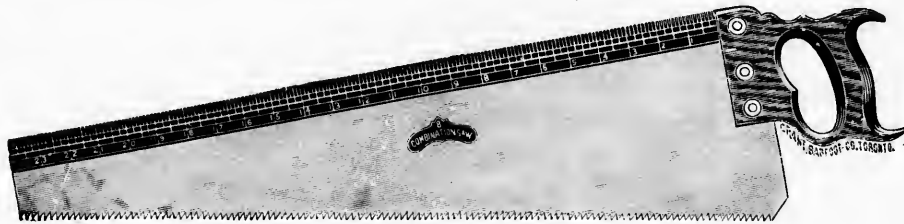

COMBINATION. No. 12

No. 12—Cast Steel Hand Saws, 26 inch..... per doz. \$11.50



BUILDERS FAVORITE. No. 50

No. 50—Silver Steel, Apple Wood Handle, Raised Screws, 26 inch..... per doz. \$21.50

Quarter dozen in a package.

HAND, PANEL AND RIP SAWS



SHURLY & DIETRICH. No. 45, "D.S."

No. 45—D. S., Silver Steel, Highly Finished Blade, Apple Wood Handle, Raised Screws, 26 inch.... per doz. \$27.50



SHURLY & DIETRICH. No. 2

Silver Steel, Satin Finished Blade, Apple Wood Handle, Raised Screws.

Length.....	16	18	20	22	24	26	28 inch.
No. 2—Hand Saws..... per doz.	\$15.00	17.00	19.00	21.00	23.00	25.00	28.00
" 2—Rip ".....	25.00	28.00



SHURLY & DIETRICH. No. 4 1/2

Spring Steel, Warranted. Beech Handle.

Length.....	16	18	20	22	24	26	28 inch.
No. 4 1/2—Hand Saws..... per doz.	\$9.50	12.00	14.50	16.00	18.00	20.00
" 4 1/2—Rip ".....	20.00	22.50



SHURLY & DIETRICH. No. 4

Spring Steel, Warranted. Beech Handle.

Length.....	18	20	22	24	26	28 inch.
No. 4—Hand Saws..... per doz.	\$11.50	14.00	15.50	17.50	18.00
" 4—Rip ".....	18.00	21.00
" 5—Hand or Rip Saws.....	18.00	21.00

The No. 5 Saw has straight back, in other particulars the same as No. 4.

One-third dozen in a box.

HAND, PANEL AND RIP SAWS



VICTORIA

Silver Steel, Highly Finished Blade, Carved Beech Handle, Raised Screws.

Victoria Hand Saws, length 26 inches	per doz.	\$17.50
" Rip " " 26 "	"	17.50



HAND AND PANEL SAWS

DISSTON'S

Length	16	18	20	22	24	26 inch.
No. 9—Apple Handle, Polished Edge..... per doz.	\$17.00	19.00	23.00	24.00
" D8— " " Hollow Back "	16.00	17.50	19.50	21.00	22.00
" 8— " " " "	\$13.50	14.50	16.50	18.50	20.00	21.00
" 76— " " " "	14.00	16.00	18.00	19.00	20.00
" 7—Beech Handle " (Disston) "	\$13.00	14.00	16.00	18.00	19.00	20.00
" 107— " " (Keystone) "	\$11.00	12.25	13.50	15.00	16.00	17.00

RIP SAWS

DISSTON'S

Nos.....	9	D8	8	76	7	107
28 inch, 4½ to 6 points..... per doz.	\$28.00	25.00	24.00	23.50	23.50	20.00
26 inch, 4½ to 6 points..... "	22.00	20.00	20.00	17.00

BACK OR TENON SAWS

DISSTON'S

Length	8	10	12 inch.
No. 4—Apple Handle, Blued Back..... per doz.	\$19.00	14.00	16.00
" 77—Mechanic's Own, Bright Back..... "	18.00	20.00

BACK OR TENON SAWS



SHURLY & DIETRICH

Length	8	10	12	14 inch.
No. 2—Extra Refined Spring Steel, Polished Back, Etched, Beech Handle...	\$13.50	15.50	17.50	19.50

COMPASS SAWS

HENRY DISSTON & SONS' BEST OF SAWS

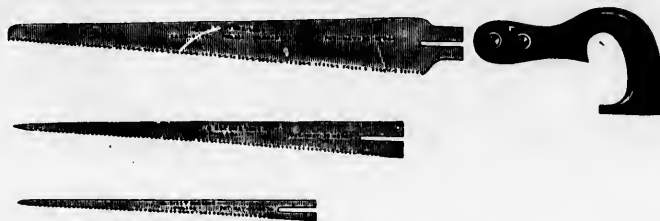

No. 3—Combining one each, Keyhole, Compass, and Pruning Saw	per doz. sets	\$11.00
Extra Blades, Keyhole	per doz.	1.75
“ “ Compass	“	2.75
“ “ Pruning	“	4.75
Extra Handles, with Screws	“	1.75

Three sets in a box.



Length		10	12	14	16 inch.
No. 18—Silver Steel	per doz.	\$5.25	5.50	5.75	6.00
“ 19—Cast Steel	“	3.50	3.75	4.00	4.50
“ 20— “	“	3.25	3.50	3.75	4.25
“ 2—Disston's Cast Steel	“	4.50	4.75	5.00

Nos. 18 and 19 are ground thin on back.

KEYHOLE SAW AND PAD



No. 5—Keystone Saw, Iron Pad	per doz.	\$2.00
------------------------------------	----------	--------

PRUNING SAWS

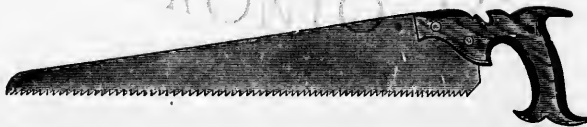

No. 16—18-inch Pruning Saws	per doz.	7.50
-----------------------------------	----------	------



No. 17—18-inch, Coarse Teeth on one side, Fine on the other	per doz.	8.00
---	----------	------

Half-dozen in a package.

BUTCHER SAWS



Length	16	18	20	22	24	26 inch.
No. 2—Shurly & Dietrich, Oval Back	per doz. \$10.00	17.33	18.50	19.60	20.75	21.85

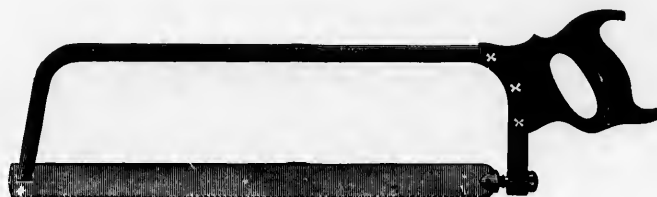

Length.....	16	18	20	22	24 inch.
No. 1—Disston's, Oval Back.....	per doz. \$17.25	18.25	19.25	20.25	21.50



Length.....	20	22 inch.
No. 4—Disston's, Flat Back.....	\$21.50	22.50



Length.....	20	22	24 inch.
No. 6—Disston's, Oval Back, Thumb Nut Attachment.....	per doz. \$20.00	21.00	22.00

One-third dozen in a box.

BUTCHER SAWS



Length..... **16** **18** **20** **22** inch.
 No. **06**—Shurly & Dietrich. Flat Back, 1½ inch Riveted Blade per doz. \$12.55 13.45 14.00 14.75
 “ **7**—Kitchen Saw, Round Back, Riveted Blade, length 14 inchesper doz. \$8.00
 Quarter-dozen in a package.



No. **115**—Boker's Knife Saw, 12 inch Blade, Varnished Handleper doz. \$4.75

PORK PACKERS' SAWS

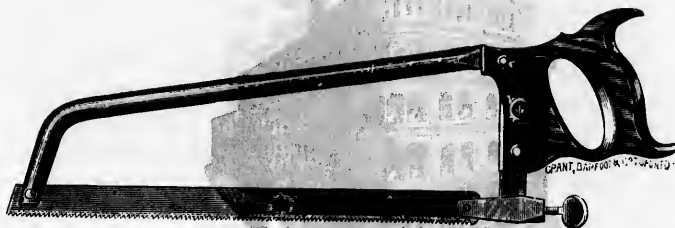

Length..... **16** **18** inch.
 No. **04**—Silver Steel, with Patent Buckleper doz. \$16.00 17.00

DEHORNING SAWS

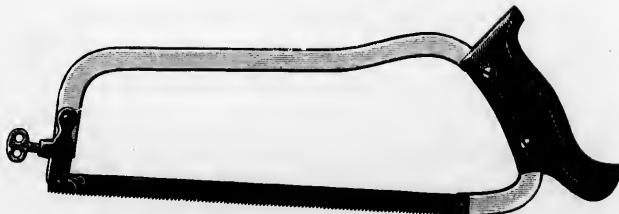

No. **0**—Beech Handle, Nicked Frame, 10 inchper doz. \$8.25
 No. **115**, half-dozen in a package, others quarter-dozen.

26 inch.
21.85

24 inch.
21.50

22 inch.
22.50

24 inch.
22.00

AXES



LEADER
 Leader, Single Steel, Bronze Finish per doz. \$7.25
 Assorted Weights, 3½ to 4½, 3¾ to 4½, 4 to 4¾ lbs.



FOREST BEAUTY
 Forest Beauty, Single Steel, Overcoat, Bronze Finish per doz. 7.75
 Assorted Weights, 3 to 3½, 3½ to 4½, 3¾ to 4½, 4 to 4¾ lbs.



TRY ME
 Try Me, Double Steel, Bronze Finish per doz. 9.50
 Assorted Weights, 3 to 3½, 3½ to 4½, 3¾ to 4½, 4 to 4½, 4½ to 5 lbs.
 One dozen in a box.

...each \$10.00
 .. " 12.00

...ing. When
 ...iring a second
 ...en 5 inches, 3½

26 inch.

7.87
 8.00

er doz. \$6.33
 " 3.50
 " 6.33

24 inch.
 6.15

18 inch.
 2.93

10 inch.
 2.00

AXES



ALBERTA

Alberta, Double Steel, Bevelled, High Ridge, Bronze Finish per doz. \$10.00
 Assorted Weights, 3½ to 4½, 3¾ to 4¾, 4 to 4¾, 4¼ to 5 lbs.



STANLEY

Stanley, Double Steel, High Ridge, Bronze Finish per doz. 11.00
 Assorted Weights, 3½ to 4½, 3¾ to 4¾, 4 to 4¾, 4¼ to 5 lbs.



UNCLE SAM

Uncle Sam, Triple Steel, Painted Green per doz. 12.00
 Assorted Weights, 3¾ to 4¾ lbs.
 One dozen in a box.

AXES



MODEL

Model, Triple Steel, Forged Bevel, Blued Finish per doz. \$11.50
 Assorted Weights, 4 to 4½, 4½ to 5 lbs.

doz. \$10.00



GEORGIAN BAY

Georgian Bay, Triple Steel, Bronze Finish per doz. 13.50
 Assorted Weights, 4 to 4½, 4½ to 5 lbs.

doz. 11.00



EMPIRE

Empire, Triple Steel, Full Polished per doz. 13.50
 Assorted Weights, 3½ to 4½, 4 to 4½, 4½ to 5 lbs.
 One dozen in a box.

doz. 12.00

AXES



BLACK PRINCE, SCORING
Black Prince, Scoring, Double Steel, Bronze Finish per doz. \$13.00
 Assorted Weights, 4½ to 5½ lbs.



ONTARIO PATTERN
Ontario Pattern, Double Bitted Axe, Ground Thin, Special Temper, Bronze Finish per doz. 18.75
 Assorted Weights, 3½ to 4½ lbs.



BRITISH COLUMBIA PATTERN
British Columbia Pattern, Double Bitted Axe, Inserted Steel, Bronze Finish per doz. 18.75
 Assorted Weights. One dozen in a box.

HANDLED AXES



Hunters' Axes, Cast Steel, $3\frac{1}{2}$ Inch Cut, 16 Inch Handles per doz. \$6.75



Hunters' Tomahawks, Cast Steel, Full Polished, $3\frac{1}{2}$ Inch Cut, 14 Inch Handles per doz. 7.75
One dozen in a box.



Leader, Single Steel, Bronze Finish, 36 inch Handles per doz. \$10.25
Forest Beauty, Single Steel, Bronze Finish, 36 inch Handles " 10.75
Try Me, Double Steel, " " 36 " " " 12.50
Monarch, Triple " " " 36 " " " 13.25

BOYS' HANDLED AXES

Boys' Handled Axes, Cast Steel, Bronze Finish, 28 inch Handles per doz. 8.25

AXE WEDGES



FULL SIZE

Perfection Axe Wedges, Japanned per gross 4.25
One dozen in a box.

FIREMEN'S AXES

HANDLED

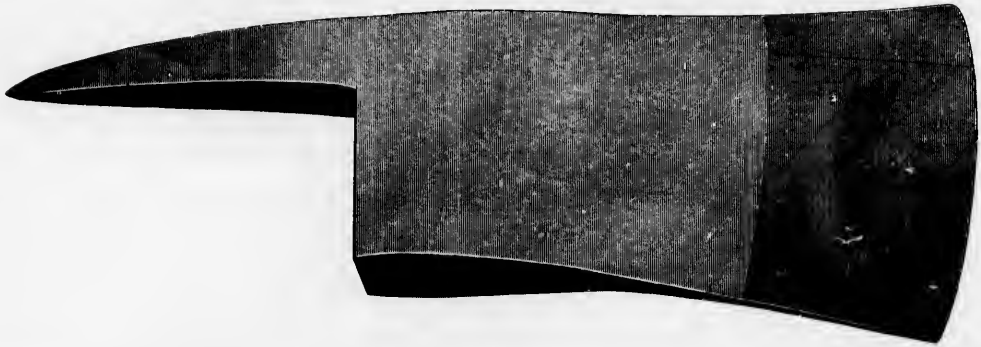

Extra Cast Steel, Finished in Red and Gold, 36 inch Handles.....each \$3.75

SHIP CARPENTERS' AXES



Extra Cast Steel Ship Carpenters' Axesper doz. 30.00

BROAD AXES

OTTAWA PATTERN



each \$3.75

30.00

Weight.....	6 to 7½	7½ to 8	8 to 9¼	9½ to 10 lbs.
Per dozen.....	\$35.00	38.50	38.50	44.50

Half-dozen in a box.

ADZES



CARPENTERS'



SHIP CARPENTERS'

Star, Steel Poll	per doz.	\$18.00	No. 33—Extra Cast Steel, Plain.....	per doz.	\$21.00
No. 1—Extra Cast Steel, 4½ to 4¾ in. cut.	“	21.00	“ 34— “ “ Lipped	“	24.00

RAILROAD ADZES

5 inch Cut, Extra Heavy	per doz.	27.00
-------------------------------	----------	-------

BENCH AXES

HANDLED



Warnock's Extra Cast Steel.

\$21.00
24.00

Nos.....	2	3	4	5	6	7	
Cut.....	4	5	5½	6	6½	7½	inch.
Per dozen	\$12.00	13.00	14.50	16.00	18.00	19.50	

Half-dozen in a box.

27.00

HATCHETS

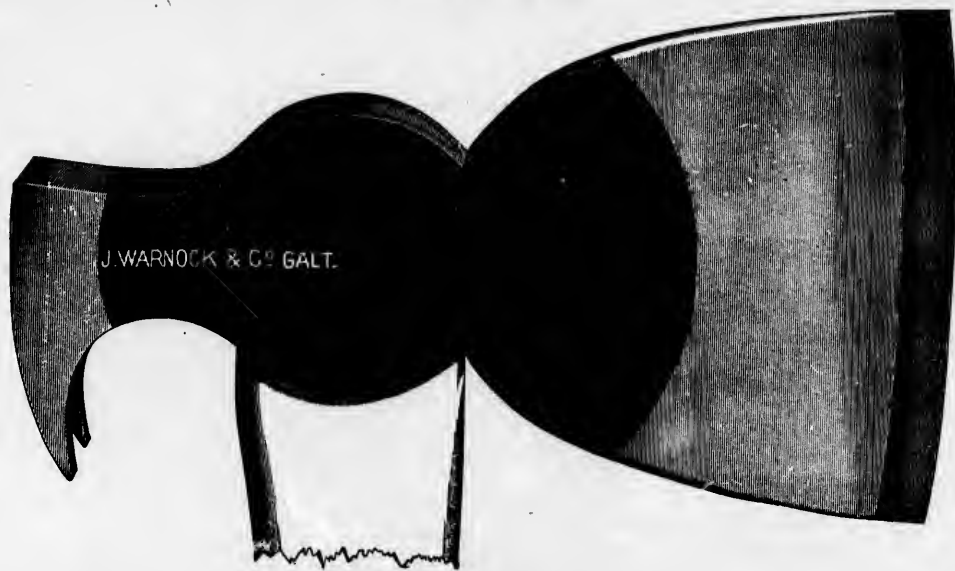

CLAW

- No. 18—Warnock's, Extra Cast Steel, Polished and Bronzed, 3½ inch Cut..... per doz. \$10.50
 " 7—Champion, Cast Steel, Polished and Bronzed, 3 inch Cut..... " 6.10

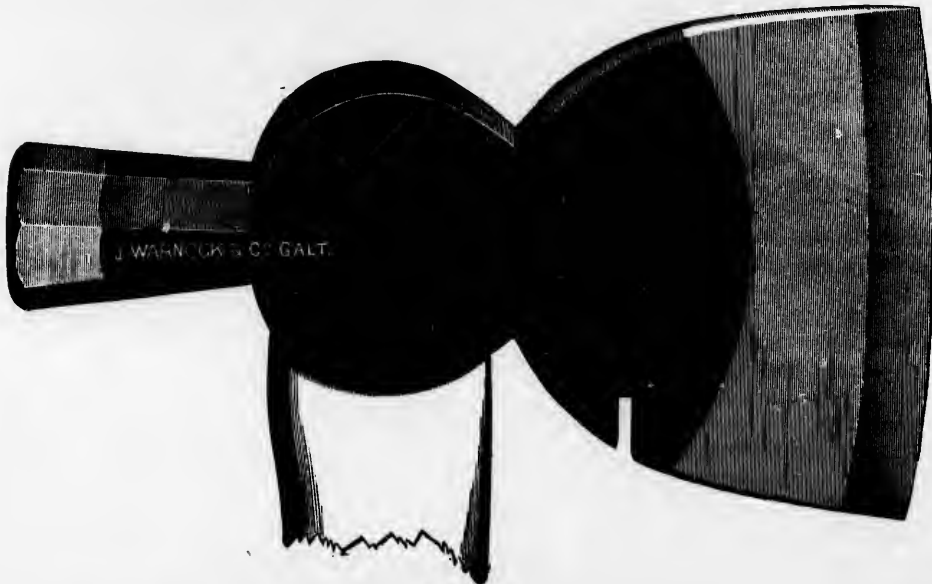

SHINGLING

- No. 17—Warnock's, Extra Cast Steel, Polished and Bronzed, 3½ inch Cut..... per doz. \$9.50
 " 1—Champion, Cast Steel, Polished and Bronzed, 3 inch Cut..... " 5.00
 " 2—Cast Steel, Polished and Painted, 3½ inch Cut..... " 3.00

Half-dozen in a box.

HATCHETS



LATHING

- No. 5—Boston Pattern, Extra Cast Steel, Full Polished, 2 inch Cut..... per doz. \$7.15
 " 6—Underhill Pattern " " 2 " " 9.25

RICE LEWIS & SON



No. 10

LATHING

- No. 10—Bell Face, 1½ inch head, Extra Cast Steel, Polished, 2½ inch Cut..... per doz. \$9.25
 " 45—Toronto Pattern, same as No. 10 but Head ½ inch larger, 2 inch Cut " 11.40

Half-dozen in a box.

doz. \$9.50
 5.00
 3.00

HATCHETS



LATHING

No. 15—New Boston Pattern, Extra Cast Steel, Full Polished, 2 inch Cut..... per doz. \$11.40



No. 1.

LATHING

No. 1—Warnock's, Extra Cast Steel, Polished and Bronzed, 2 $\frac{3}{8}$ inch Cut	per doz.	\$8.25
" 2— " " " " " " " 3 " "	"	9.25
" 3—Champion " " " " " " " 2 $\frac{3}{8}$ " "	"	5.00

Half-dozen in a box.

LUMBERING TOOLS



No. 36

No. 36—Timber Grips, for Rafting, Millyard or Builders' use per doz. \$43.20

PEAVEY AND CANT HOOK HANDLES, MAPLE



Length		4	4½	5	5½	6 feet.
No. 39—Peavey Handles	per doz.	\$3.25	3.50	4.00	4.50	5.00
" 36—Cant Dog Handles	"	3.25	3.50



No. 9



No. 9½



No. 12

No. 9—Peavey Sockets	per doz.	\$3.00
" 9½— "	"	3.90
" 12—Band and Bolt, Swedes Iron.	"	5.40



No. 7



No. 11

No. 7—Duck Bill Hook and Band	per doz.	13.00
" 8—Chisel "	"	10.80
" 10—Duck Bill Hooks only	"	7.60
" 11—Chisel "	"	5.40

BOOT CALKS



Nos. 0 1 2 3 4

No.	0	1	2	3	4
	SMALL BALL	MEDIUM BALL	LARGE BALL	SMALL HEEL	LARGE HEEL
Per 1000	\$6.00	7.00	8.00	10.00	10.00

Medium and Small Ball and Small Heel, 500 in a box ; Large Ball and Large Heel, 250.

CALK PUNCH AND SET

Calk Punch and Set, made of Hardened Cast Steel, Polished per doz. \$3.00

LUMBERING TOOLS

SOREW CLEVIS

TIMBER DOG

CHAIN GRAB RING

CHAIN ROUND RING

STEEL SAW
WEDGE



No. 22



No. 23



No. 25



No. 26



No. 27

Nos.	22	23	25	26	27
Per dozen.....	\$3.25	1.45	2.80	2.00	3.25

RICE LEWIS & SON
LIMITED
SWEDES IRON PILING HOOKS



No. 13



No. 14



No. 15



No. 16



No. 17

Nos.	13	14	15	16	17
Per dozen.....	\$27.00	21.60	12.00	11.90	9.75

TORONTO, ONT.

GRAB HOOK

ROUND CHAIN HOOK

BAR BOOM HOOK

RING BOOM HOOK



No. 18



No. 19



No. 20



No. 21

Nos.	18	19	20	21
Per dozen.....	\$4.00	4.00	5.40	6.50

LUMBERING TOOLS

OAK WHIFFLETREES



No. 33

No. 33—Oak Whiffletrees, Ironed	per set	\$3.00
" 43— " " Eveners	each	0.75
" 56— " Single Trees, Ironed	"	1.25

BOOM CHAINS

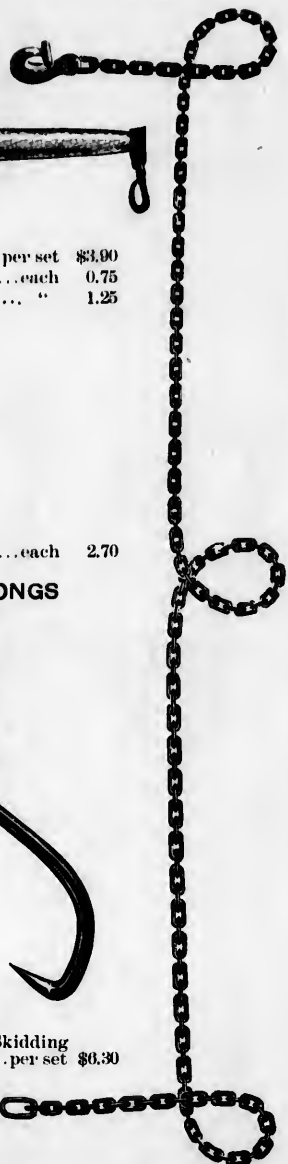

No. 29

OAK NECK YOKES



No. 34

No. 34—Oak Neck Yokes, Ironed, Heavy, 3 feet 3 inches long	each	2.70
--	------	------

KNOCK DOWN CHAINS FOR RAFTING



No. 28

No. 28—Knock Down Chains	per doz.	\$6.75
--------------------------------	----------	--------

SKIDDING TONGS



No. 35

No. 35—Cast Steel Skidding Tongs	per set	\$6.30
---	---------	--------

WHIFFLETREE, MIDDLE END



No. 24

Per doz	\$4.95
---------------	--------

WHIFFLETREE, IRON END



No. 24½

Per doz	\$4.15
---------------	--------

BOOM CHAINS

No. 29—Boom Chains, all sizes, furnished with all styles of Hooks, also with Toggle and Ring. When ordering Boom Chains, state length, also kind of fastener required. Logging Chains all sizes, as ordered.

ICE TOOLS



MARKER, WITH SWING GUIDE

No. 1—3½ inch Cast Steel Markers, 11 Cutting Teeth with Swing Guide, complete.....each \$101.50



THE "ICE KING"



No. 7, ICE PLOW

No. A—"Ice King," 7 inch, 5 Cutting Teeth, 22 inch Swing Guide with Shoe.....	each \$43.75
" 6— 8 inch Cast Steel Ice Plows, 7 Cutting Teeth, weight with case 115 lbs.....	" 84.00
" 7— 9 " " " 7 " " 120 lbs.....	" 80.25
" 8—10 " " " 6 " " 125 lbs.....	" 92.75

The No. A "Ice King" is suitable for Dairymen, Butchers and Farmers, the teeth are not ground and polished, but are left blue.

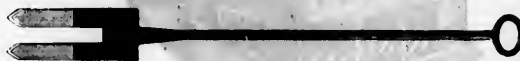

No. 31½—Splitting Forks, length 4 ft. 7½ in., Tines 12 in. long, weight 15½ lbs.....each \$7.65



No. 35—Fork Bars, length 4 ft. 9 in., Forks 8 in. wide, weight 16 lbs.....each 8.00



No. 42—Bar or Packing Chisels, length 4 ft. 7 in., Blade 12 x 4½ in., weight 15½ lbs..... each 5.75



No. 100—Ice Hooks, 4 and 4½ ft., Turned Ash Handles.....	per doz. 18.25
" 100— " 5 ft. " "	" 16.65

Cast Steel Ice Saws, see page 201.

TRACK AND CROWBARS

CLAW BARS



Claw Bars with Heel, Solid Steel.....per lb. \$....

FLAGGING BARS



Flagging Bars, Solid Steel.....per lb.

TAMPING BARS



Tamping Bars, Solid Steel.....per lb.

CROWBARS



WEDGE POINT



PINCH POINT

Crowbars, Solid Steel, Assorted Weights.....per lb.

RAILROAD TRACK TOOLS

SCREW RAIL BENDER OR "JIM CROW"

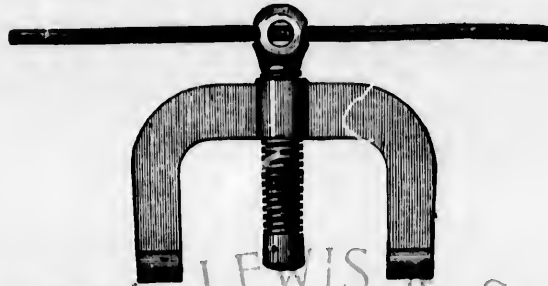

Screw Rail Benders or "Jim Crows".....each \$.....

These Benders can be made to suit any section of rail; when ordering, a sectional drawing of rail should be sent.

RAIL TONGS



Rail Tongs, Solid Steel, Weight 15 to 25 lbs.....per lb. \$.....

RAIL OR CONSTRUCTION CARS

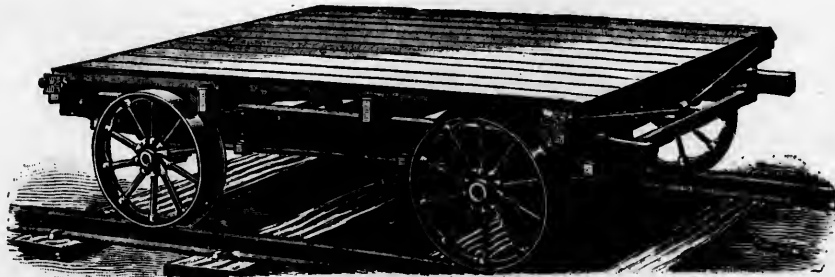

We are prepared to make to order, on short notice, Push Cars for use in laying track, etc. Prices on application.

TACK CLAWS AND HAMMERS

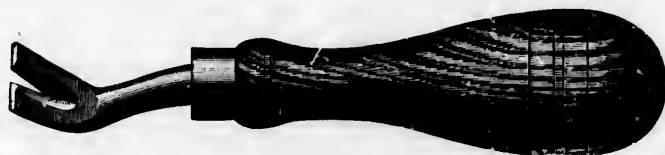

No. 0—Wood Handle, Short Shank, Polished.....per doz. \$0.65



No. 46—Wood Handle, Flat Polished Steel Blade, Riveted Tangper doz. 1.40
 " 15—Drop Forged Steel, Polished, Length 6 $\frac{3}{4}$ inch..... " 3.05

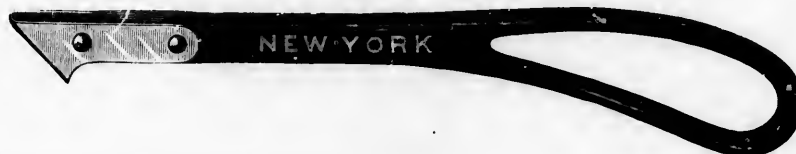

No. 20—Malleable Handle, Tempered Steel Points.....per doz. 1.50

TACK HAMMERS

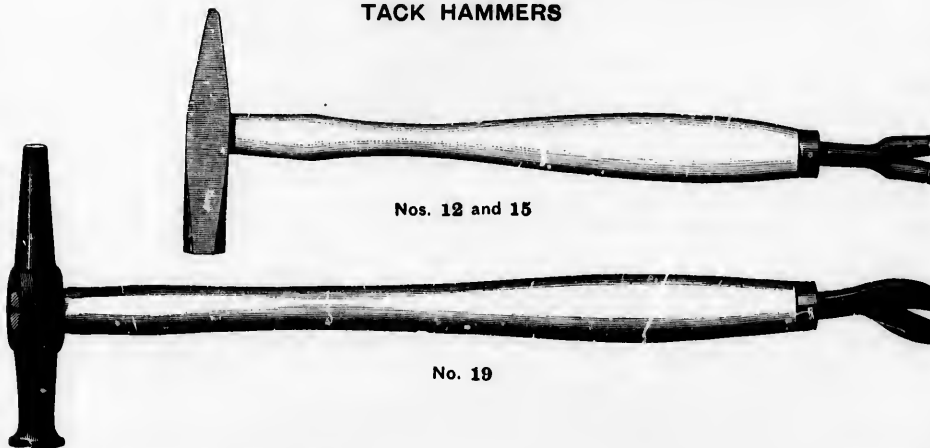

No. 160—Wood Handle, Claw Head, Polished.....per doz. 1.30
 " 12— " Imitation Cast Steel, Polished, Large " 1.05
 " 15— " " " " " " " " " 0.95

No. 160 is the same pattern as an ordinary Claw Hammer, only lighter.

No. 19—Wood Handle, Magnetic Head, Japanned.....per doz. 1.85

One dozen in a box.

UPHOLSTERERS' HAMMERS

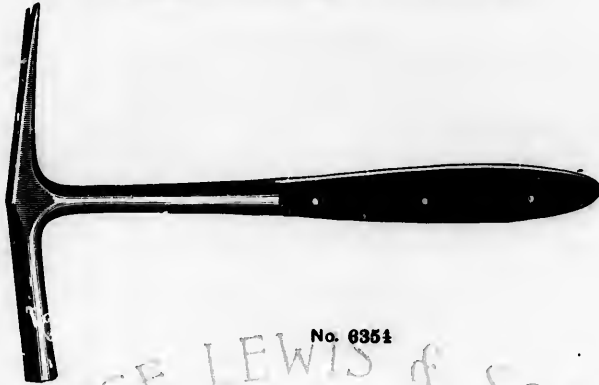

No. 6354

No.	34—Polished Steel Head, with Claw	per doz.	\$1.75
"	10117—Bright Steel Head, without Claw	"	7.00
"	10118— " " " with "	"	7.25
"	2031K— " " " without "	"	7.75
"	6354—Polished " " with "	"	17.85

Half-dozen in a box.

STEEL FACED SHOE HAMMERS

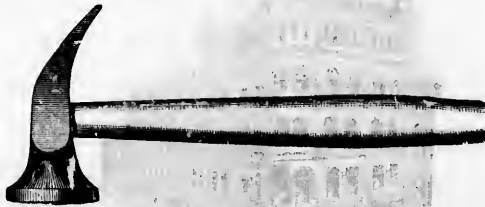

No. 2—Shoe Hammer, Steel Faced		per doz.	6.90
--------------------------------------	--	----------	------

Half-dozen in a package.

RIVETING HAMMERS

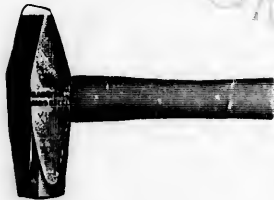

Cast Steel, Plain Eye.

No.	010	012	013	014	014½
Weight	1½ lb.	1½ lb.	13 oz.	7 oz.	4 oz.
Per dozen	\$8.50	7.50	6.50	5.50	5.00

TINNERS' HAMMERS



Cast Steel, Plain Eye, Square.

No.	000	00	0
Weight	1 lb.	14 oz.	12 oz.
Per dozen	\$8.50	7.50	6.75

Half-dozen in a box.

The weights given do not include weight of handles.

NAIL HAMMERS



Full size, No. 1½

ADZE EYE, SOLID CAST STEEL HAMMERS, HANDLED

Nos.	0	1	1½	3	21	22		
Weight.	1½	1½	1	½	1	1½	lbs.	
Per doz.	\$9.50	8.50	7.50	7.00	5.50	6.50		
No. 101½—Adze Eye, Steel, Full Polished, Weight 1 lb. 4 oz.							per doz.	\$3.15
“ 102 — “ Cast Iron, Full Polished, Weight 1 lb. 3 oz.								2.25
“ 103 — “ “ Nickel-Plated, Weight 1 lb. 3 oz.								2.65

BRAD HAMMERS

No. 30—Adze Eye, Solid Cast Steel, Polished, Weight 7 oz. per doz. 4.50



Full size, No. 61½

ADZE EYE, BELL FACE, SOLID CAST STEEL HAMMERS, HANDLED

Nos.		01	61½	63		
Weight.		1½ lbs.	1 lb.	7	oz.	
Per dozen		\$8.50	7.50	7.00		
No. 10—Cast Iron, Weight 1 lb. 3 oz.					per doz.	\$3.10

Half-dozen in a box.

The weights given do not include weight of handles.

NAIL HAMMERS

MAYDOLE'S

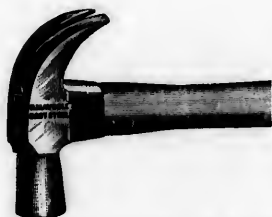

Nos. 1 and 1½, ROUND FACE



Nos. 11, 11½ and 13, BELL FACE

Maydole's Adze Eye, Solid Cast Steel, Handled.

Nos.	1	1½	11	11½	13
Weight.	1½ lbs.	1 lb.	1 lb. 3 oz.	1 lb.	7 oz.
Per dozen	\$8.75	8.00	8.75	8.00	6.75

IMPROVED NAIL-HOLDING HAMMER, HANDLED



No. 50

No. 50—Adze Eye, Solid Cast Steel, Weight 1½ lbs. per doz. \$12.50

By this improvement free use of the hands is given when driving the nail beyond the ordinary reach.

BOX OPENING HAMMER, HANDLED



No. 111

No. 111—Solid Cast Steel, Weight 1½ lbs. per doz. 10.00

Half-dozen in a box.

The weights given do not include weight of handles.

22
1½ lbs.
6.50
per doz. \$3.15
2.25
2.65

per doz. 4.50

63
7 oz.
7.00
oz. \$3.10

BLACKSMITHS' HAMMERS

HANDLED

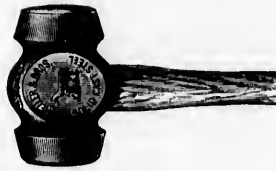

No. 16

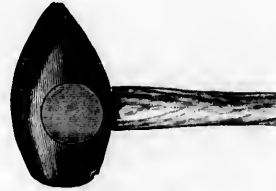

No. 17

No. 16—Heller & Bros.' Rounding Hammers, with Handles, 2 to 3 lbs	per doz.	\$24.00
" 17— " " " Cat's Head or Turning Hammers, with Handles, 2 to 3 lbs	"	24.00

Quarter-dozen in a box.

FARRIERS' HAMMERS

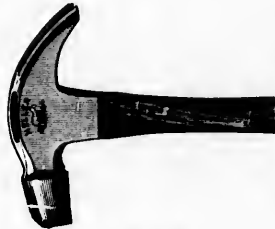

No. 18

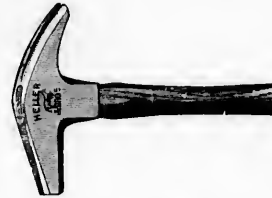

No. 19

No. 18—Heller & Bros.' Driving Hammers, with Handles, 13 to 20 oz	per doz.	\$12.50
" 19— " " " " " " 11 to 20 "	"	10.00

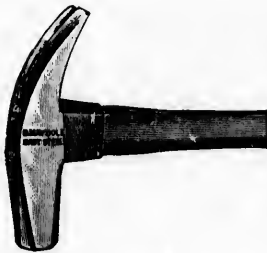

No. 152

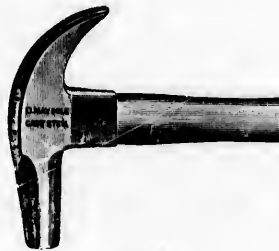

No. 253

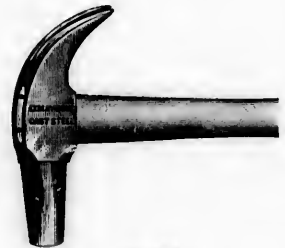

No. 55

No. 152—Maydole's Driving Hammers, with Handles, Boston Pattern, 10 oz.	per doz.	\$8.00
" 253— " " " " " Adze Eye, Round, 8 "	"	7.00
" 27—Gardner's " " " " Boston Pattern, 15 "	"	8.00
" 53— " " " " Adze Eye, Octagon, 10 "	"	7.50
" 55— " " " " Plain Eye, Round, 8 "	"	5.00

Half-dozen in a box.

The weights given do not include weight of handles.

MACHINISTS' HAMMERS



**No. 8
CROSS PEIN**



No. 22, BALL PEIN



**No. 9
STRAIGHT PEIN**

Solid Cast Steel, Octagon, without Handles.

Weights	1/2	3/4	1 to 3 lbs.
No. 22—Ball Pein	per lb.	\$0.52	0.32
" 8—Cross Pein	"	"	0.32
" 9—Straight Pein	"	"	0.32

MACHINISTS' COPPER HAMMERS



Pure Copper, with Hardwood Handles.

Nos.	1	2	3	4	5	6	
Weight	1/2	1	1 1/2	2	2 1/2	3	lbs.
Each	\$0.75	1.15	1.35	1.65	2.05	2.40	

CAST IRON SLEDGES



With Round Tapering Body.

Weights 10 to 12 lbs. per lb. \$0.06

BLACKSMITHS' SLEDGES



No. 45

Solid Cast Steel, Polished Face and Pein.

No. 45—Cast Steel Sledges, Cross Pein, Weights 6 to 14 lbs.	per lb.	\$0.11 1/2
" 141—Peter Wright's C. S. Cross Pein Sledges, 2 1/2 to 4 lbs.	"	0.21
" 139— " " " Double-Faced Sledges, 3 1/2 to 8 lbs.	"	0.21

BLACKSMITHS' TURNING SLEDGES



Cast Steel Turning Sledge, Octagon, without Handles.

No. 15—Heller & Bros., Weights 5 to 10 lbs.per lb. \$0.30½

COLD CHISELS



No. 78—Cast Steel Cold Chisels, Weights 1 to 3 lbs.per lb. 0.25

HARDIES



No. 83

FLATTERS



No. 84

No. 83—Cast Steel Hardies, Shanks $\frac{1}{4}$ to $1\frac{1}{2}$ inches square.per lb. 0.25

" 84— " Flatters, 1 to $\frac{1}{4}$ inches " 0.25

BLACKSMITHS' TOOLS

SWEDGES



No. 77, BOTTOM



No. 78, TOP

No. 77—Cast Steel Bottom Swedges, Sizes $\frac{1}{4}$ to 3 inches.....per lb. \$0.30
 " 78— " Top " " $\frac{1}{4}$ to 3 " " 0.30

FULLERS



No. 79, TOP



No. 80, BOTTOM

No. 79—Cast Steel Top Fullers, Sizes $\frac{1}{4}$ to 3 inches.....per lb. 0.25
 " 80— " Bottom " " $\frac{1}{4}$ to 3 " " 0.25

BLACKSMITHS' PUNCHES AND CREASERS



No. 81



No. 82



No. 85

No. 81—Round Punches, Sizes $\frac{1}{4}$ to 1 inch.....	per lb.	\$0.25
" 82—Square " " $\frac{1}{4}$ to 1 "	"	0.25
" 85—Adze Eye Creaser	"	0.25

STONE WEDGES



No. 73—Stone Wedges, Weights 2 to 6 lbs.....	per lb.	0.10
--	---------	------

WOOD CHOPPERS' WEDGES



No. 69—Wood Choppers' Wedges, Truckee Pattern, weight as desired.....	per lb.	0.10
---	---------	------

STRIKING OR MINING HAMMERS



No. 57—Cast Steel, Western or Long Pattern, Polished Faces, 3 to 5 lbs.....per lb. \$0.14
 " 57— " " " " " " over 5 lbs..... " 0.114

HAND DRILLING OR STONE CUTTERS' HAND HAMMERS



No. 54—Cast Steel, Eastern or Short Pattern, Polished Faces, 3 to 5 lbs.....per lb. 0.14
 " 54— " " " " " " over 5 lbs..... " 0.114

NAPPING HAMMERS



No. 58—Cast Steel Napping Hammer, Polished Faces, 1½ to 3 lbs.....per lb. 0.14

TRACK MAULS



No. 65—Cast Steel Railroad Track Mauls, Polished Face and Point, 7 to 10 lbs.....per lb. 0.13

SHIP MAULS



No. 66—Cast Steel Ship Mauls, Polished Face, 4½ to 6 lbs.....per lb. \$0.19

SINGLE FACE SPALLING OR STONE HAMMERS



No. 50—Cast Steel Spalling or Stone Hammers, Polished Face, 3 to 5 lbs.....per lb. 0.14

“ 50— “ “ “ “ over 5 lbs..... “ 0.13

STONE AXES

TWO CUTTING EDGES

No. 52—Cast Steel Stone Axes, Weight 5 to 12 lbs.....per lb. 0.15½

DOUBLE FACE SPALLING OR STONE HAMMERS



No. 51—Cast Steel Spalling Hammers, Polished Double Face, 12 to 22 lbs.....per lb. 0.13

STONE SLEDGES

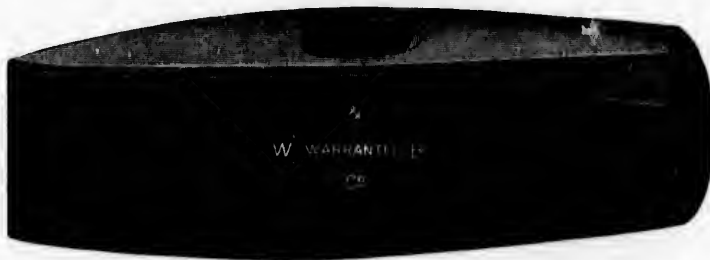

No. 48—Cast Steel Stone Sledges, Polished Face, 16 to 26 lbs. per lb. \$0.11½

BUSH HAMMERS



No. 53—Cast Steel Masons' Bush Hammers, 3 to 5 lbs. per lb. 0.00
 " 53— " " " " over 5 lbs. " 0.56

FOULDS' MULTIPLEX STONE CUTTERS



No. 1

No. 2

No. 3

The Handles are Malleable Iron; the Blades are Cast Steel, Adjustable and Reversible.

Width		½	1	2	3
Handles, separate	each	\$0.25	0.25	0.30	0.40
Nos. 2 or 3 Cutters	"	0.06	0.06	0.06	0.12

LEAD WIRE, for use in Handle Socket per hank \$0.50

MASONS' STONE PICKS



No. 64—Cast Steel Masons' Stone Picks, 5 to 12 lbs. per lb. 0.26

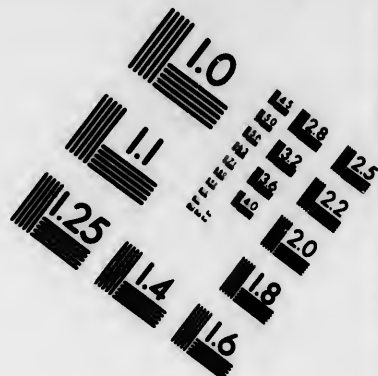
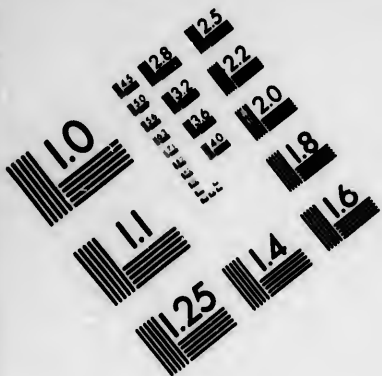

**IMAGE EVALUATION
TEST TARGET (MT-3)**

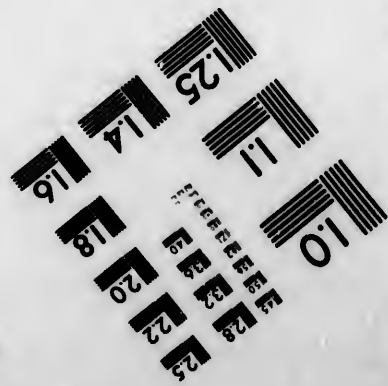
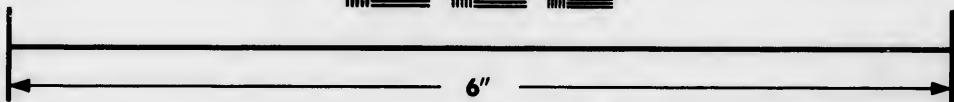
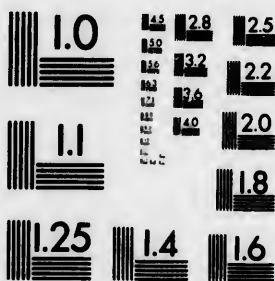

**Photographic
Sciences
Corporation**

23 WEST MAIN STREET
WEBSTER, N.Y. 14590
(716) 872-4503

1.8
2.0
2.2
2.5
2.8
3.2
3.6
4.0

10
11

GRUB HOES AND MATTOCKS



GRUB HOE



EDGE MATTOCK

Grub Hoes, Round Eye, 4½ inch Cutter	per doz.	\$10.50
Edge Mattocks, Adze Eye, Short Cutter, 4½ inch.....	"	10.00
" " " Long " 6 inch.....	"	10.50



PICK MATTOCK

Pick Mattocks, Adze Eye.....	per doz.	10.50
------------------------------	----------	-------

2 dozen in a box.

RAILROAD PICKS



Railroad or Clay Picks, Adze Eye, Steel Pointed.

Weights, assorted	5 to 6	6 to 7	7 to 8	8 to 9 lbs. each.
Per dozen	\$7.20	7.80	8.40	9.00

Rock Picks, Solid Eye, Steel Pointed, both Ends Pointed, Assorted Weights 9 to 10 lbs. each per doz. \$12.00

COAL PICKS



Coal Picks, Solid Eye, Steel Pointed, Weights 2, 2½, 3 and 3½ lbs. each per doz. 12.00

MINERS' DRIFTING PICKS



Miners' Drifting Picks, Solid Steel, Assorted Weights 4 to 5 lbs. each per doz. 12.00

YUKON DRIFTING PICKS



Yukon Drifting Picks, Solid Steel, 28 to 30 inches long, Weight 5 to 6 lbs. each per doz. 12.00

KLONDIKE PICKS, STRAPPED



Klondike Picks, Strapped and Handled, Length 28 to 30 inches, Weight exclusive of Handle, 4½ to 5 lbs. each.
Per doz. 18.00

POLL PICKS



British Columbia Pattern, Drift Eye, Solid Cast Steel, assorted, 4½ to 5 lbs.....	per doz.	\$14.00
Prospectors' Poll Picks, " " " " 2½ to 3 "	"	12.50
" " " " 2 to 2½ " with 34 inch Handles.....	"	13.50

PROSPECTORS' PICKS



Full Polished and Handled.

No. 1—Solid Cast Steel, with 18 inch Handles, Weight, including Handle, 2 lbs.....	per doz.	9.75
Half-dozen in a box,		

IRON MORTARS AND PESTLES OR ORE-CRUSHERS



Nos. 1 and 2



No. 3

No. 1—4½ inch diameter, 4½ inch deep, Polished Inside, will hold about ½ Quart	per doz.	8.25
" 2—5½ " " 6 " " " " " 1 "	"	10.75
" 3—9 " " 8 " " " " " 3 "	each	3.00

MINERS' GOLD PANS

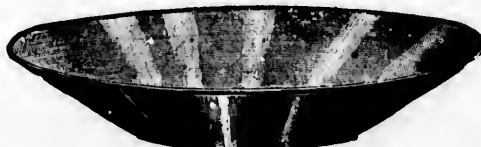

No. 1—16½ x 2½ inch, Polished.....	per doz.	3.75
" 2—16½ x 2½ " Plain.....	"	3.00

MINERS' CANDLESTICKS



Ideal, Colorado Pattern, Wrought Steel.....per doz. \$0.30

MINERS' LAMPS



With Hinged Covers.

No. 1—With Short Spouts.....per doz. \$2.85
 " 2— " Large " " 3.00

STEEL LAMPS



Copper Plated.

No. 20 $\frac{1}{2}$ — $\frac{3}{4}$ Inch Diameter.....per doz. 9.00
 " 21— $\frac{1}{2}$ " " " 12.00

POCKET GOLD SCALES



No. 1—In Tin Boxes, to weigh up to 2 ounces.....per doz. 15.00
 " 2— " " " 4 " " 17.75
 " 3— " " " 6 " " 21.00

QUICKSILVER

Quicksilver, in Metallic Flasks of 76 $\frac{1}{2}$ lbs.....per lb. 0.80
 In less quantities, Flasks extra.

PROSPECTORS' MAGNIFYING GLASSES



No. 75



No. 76

No. 75—Oxidized Metal, with one Lens, $1\frac{1}{4}$ inch diameter..... per doz. \$3.00
 " 76— " " " two Lenses, giving different powers, $1\frac{1}{4}$ inch diameter..... " 6.50



No. 77

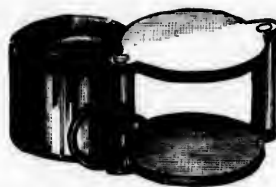

No. 85

No. 77—Oxidized Metal, with three Lenses, giving various powers, $1\frac{1}{4}$ inch diameter..... per doz. \$ 8.00
 " 85—Standard Miners' Glass, Nickel-plated Case, Double Lenses, with Diaphragm, High Magnifying Power, $1\frac{1}{4}$ inch diameter..... per doz. 13.50

POCKET COMPASSES

WITH BRASS SLIP COVERS



Nos. 50 to 52



Nos. 53 to 55

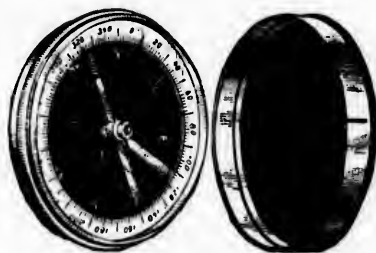

No. 56

No. 50—Card Dial, $1\frac{1}{4}$ inch diameter..... per doz. \$ 2.40
 " 51— " " $1\frac{1}{8}$ " " " " " " " " " " " " 2.00
 " 52— " " $1\frac{1}{2}$ " " " " " " " " " " " " 2.80
 " 53—Silvered Metal Dial, Full Division, $1\frac{1}{8}$ inch diameter, Needle with Jewelled Centre, with Stop " 12.50
 " 54— " " " " $1\frac{1}{2}$ " " " " " " " " " " " 13.00
 " 55— " " " " 2 " " " " " " " " " " 13.50
 " 56—Heavy Brass Case and Cover, Oxidized Metal Dial, Full Divisions on Raised Circle, $2\frac{1}{4}$ inch diameter, English Bar Needle with Jewelled Centre. It is particularly recommended for Miners' and Lumbermen's use, as it is water and dust proof, and the Needle is more easily seen at night.
 Per dozen..... 22.50

POCKET AND SURVEYORS' COMPASSES

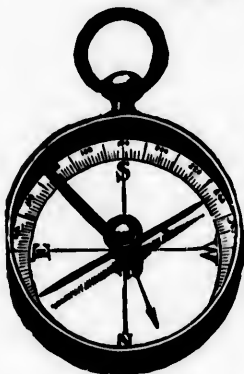

Nos. 58 to 60



Nos. 61 to 63



Style Case of Nos. 61 to 67

	Per Doz. \$
No. 57—Nickel-Plated, Open Face, Metal Dial, 1 7/8 inch diameter.....	4.50
.. 58—Brass, Open Face, Silvered Metal Dial, Full Divisions on Raised Circle, 1 7/8 inch diameter, English Bar Needle with Jewelled Centre.....	16.50
.. 59—Brass, Open Face, Silvered Metal Dial, Full Divisions on Raised Circle, 1 7/8 inch diameter, English Bar Needle with Jewelled Centre.....	17.50
.. 60—Brass, Open Face, Silvered Metal Dial, Full Divisions on Raised Circle, 2 inch diameter, English Bar Needle with Jewelled Centre.....	18.50
.. 61—Brass, Hinged Cover, Silvered Metal Dial, Full Divisions, 1 7/8 in. diam., Needle with Jewelled Centre.....	15.00
.. 62—..... 1 3/4 " " " " " " " " " " " "	16.00
.. 63—..... 2 " " " " " " " " " " " "	17.00
.. 64—Nickel-Plated Hunting Case, Watch Style, Silvered Dial, Full Divisions, 1 7/8 inch diameter, Needle with Jewelled Centre.....	21.00
.. 65—Nickel-Plated Hunting Case, Watch Style, Silvered Dial, Full Divisions, 1 7/8 inch diameter, Bar Needle with Jewelled Centre.....	28.50
.. 66—Nickel-Plated Hunting Case, Metal Dial, 1 7/8 inch diameter.....	0.75
.. 67—..... Silvered Dial, Full Divisions, 2 inch diameter, English Bar Needle with Jewelled Centre, has Automatic Spring.....	30.00



No. 86

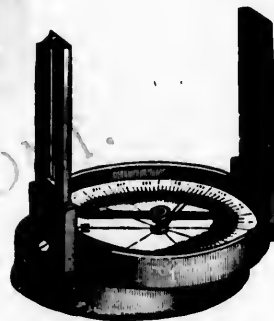

No. 87 and 88

No. 86—Surveyors' Compass, Brass Case with Ring and Slip Cover, Silvered Metal Dial, Full Divisions, 2 1/2 inch diameter, English Bar Needle with Jewelled Centre, Folding Sights.....	each \$1.25
No. 87—Surveyors' Compass, Silvered Metal Dial, with Full Divisions on Raised Circle, 3/4 inch diameter, English Bar Needle with Jewelled Centre, Folding Sights and Mounted for Jacob Staff, all fitted in Mahogany Box.....	each 7.50
No. 88—Surveyors' Compass, Silvered Metal Dial, Full Divisions on Raised Circle, 3/4 inch diameter, English Bar Needle, Folding Sights, Improved Mounting for Jacob Staff, Double Adjustment, in Mahogany Box. This Instrument is provided with two Levels for adjusting the same.....	each 0.50

POCKET TELESCOPES

ACHROMATIC



Pocket Telescopes, with Four Sections, Brass Finish, Morocco Covered.

No. 90	—1 inch Object Lens, with Magnifying Power of 12 diam., Length Closed 6 in., Extended 16 in.	each	\$3.00
" 91	—1½ " " " " " 19 " " 8 " " 23½ " " "	"	5.50
" 92	—2 " " " " " 20 " " 10½ " " 36 " " "	"	11.50

FIELD AND MARINE GLASSES

ACHROMATIC



No. 93

Nos. 95 to 97

No. 99

No. 93	—Bardon & Son, Pocket Field Glass, 1½ inch Object Lens, Excellent Power and very handy shape to be carried in the pocket. Is recommended as a Sportsman's Glass	each	\$11.50
" 94	—Field and Marine Pocket Glass, 1½ Object Lens, Morocco and Nickel Finish with Small Compass on the Bar, Good Quality Lenses	each	4.25
" 95	—Chevelier, 2½ inch Object Lens, Morocco and Black Japanned Finish, Medium Quality	each	6.50
" 96	—Lemaire, 2½ " " " " Oxidized " Large Eye Pieces for Day or Night use, High Power.	each	16.25
" 97	—Lemaire, 2½ inch Object Lens, Morocco and Black Oxidized Finish, Large Eye Pieces for Day or Night use, High Power.	each	17.50
" 98	—Marchand, 2½ inch Object Lens, Morocco and Black Japanned Finish, Large Eye Pieces for Day or Night use, Good Power	each	8.50
" 99	—La Reine, 1½ inch Object Lens, Morocco and Black Japanned Finish, Changeable Eye Pieces for Theatre, Field or Marine use, Excellent Quality Lenses	each	21.50
" 100	—Bardou, 2½ inch Object Lens, Morocco Covered, Black Oxidized Finish, Highest Grade Lenses	each	22.00

The Field and Marine Glasses are provided with a Leather Case and Strap.

THERMOMETERS

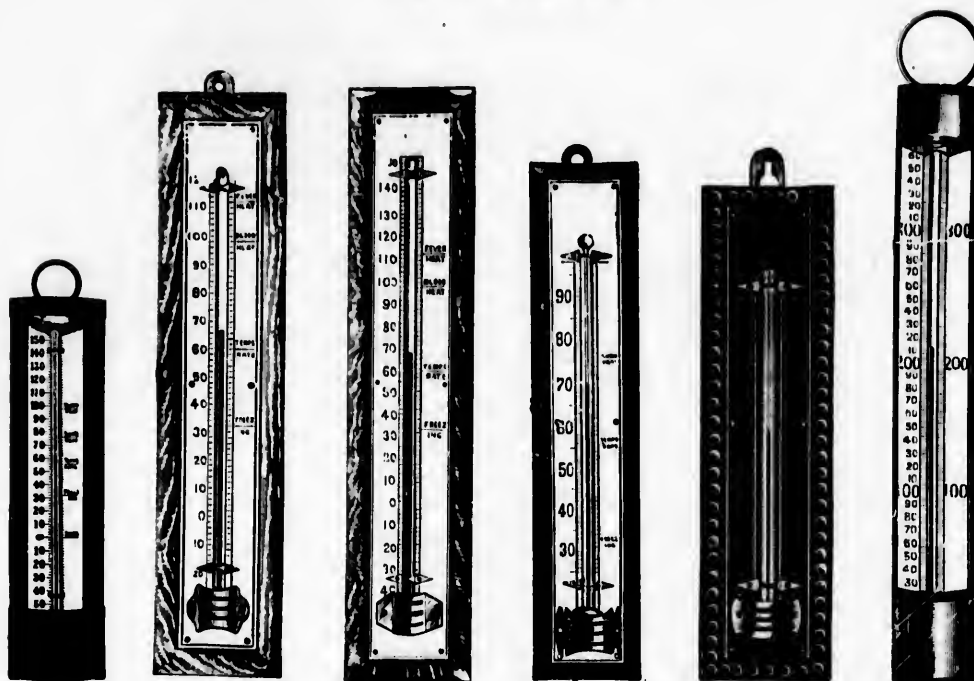

No. 30

Nos. 97 to 99

Nos. 144 to 146

Nos. 151 and 152

Nos. 100 and 101

No. 370

JAPANNED TIN CASE THERMOMETERS

Length	7	8	10 inch.
No. 30—Japanned Tin Case	\$2.00	2.25	2.65
“ 31— “ “ Ruby Tube	2.25	2.45	2.85

HOUSE OR CABINET THERMOMETERS

No. 97—Maple Back, Oval Edges, Metal Scale with Brass Trimmings, 8 inch	Per doz. \$ 3.90
“ 98— “ “ “ “ “ “ 10 “	5.20
“ 99— “ “ “ “ “ “ 12 “	7.80
“ 49—Panel, Cherry Wood Backs, “ “ “ 8 “	2.00
“ 141—Polished Oak Backs, Cove Edges, Magnifying Mercury Tube, Ivory Scale, Gilt Trimmings, 8 inch.	23.40
“ 145— “ “ “ “ “ “ “ 10 “	31.20
“ 146— “ “ “ “ “ “ “ 12 “	46.80
“ 151— “ “ “ “ “ Spirit Tube, Metal Scale, “ 10 “	26.00
“ 152— “ “ “ “ “ “ “ 12 “	36.40
“ 100—Carved Oak Backs, Fine Polish, Mercury Tube, Brass Trimmings, 8 inch.....	10.40
“ 101— “ “ “ “ “ “ “ 10 “	14.30

CONFECTIONERS' THERMOMETERS

No. 370—With Heavy Copper Case, 350° or 400°, 12 inch	per doz. 26.00
---	----------------

THERMOMETERS



370

0 inch.
15
15

Per doz.
\$ 3.00
5.20
7.80
2.60
23.40
31.20
46.80
26.00
30.40
10.40
14.30

26.00



No. 2171



No. 37



No. 184



No. 380



No. 1070B

Length.....	inch.	7	8
No. 2171—Floating Dairy Thermometers, marked Churning, Cheese, Scalding	per doz.	\$1.25	1.30
" 37—Dairy Thermometer, Bright Tin Case, Zinc Scale, marked Churning, Cheese, Scalding ..	"	2.00	2.45
" 184—Bath " " Wood Frame, Tube well protected with Brass Guard	10 inch. per doz.	5.20	
" 380—Enamel Oven Thermometer, Extra Heavy Flange, Registering 350° to 400°	12 "	"	31.25
" 1070B—Self Registering Thermometer, Wood Back, Registers Minimum and Maximum ..	10 "	"	14.50

COMBINED THERMOMETER AND BAROMETER

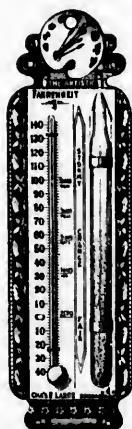

No. 50

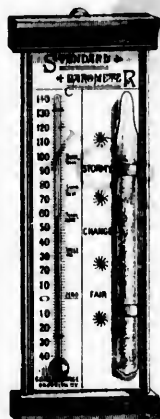

No. 51



Nos. 100 and 314

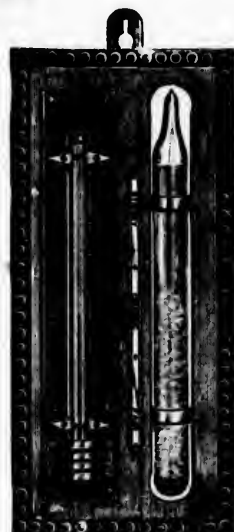

No. 78

No. 50—Artistic Barometers, Mounted on Decorated Tin Plate, Gold Lacquered Backs	per doz.	\$2.40
" 51—Standard " Cherry Moulding at each end, Tinned Slide Rods	"	2.00
" 100—Sargent's " Varnished Wood Backs, Cove Moulded Edges	"	4.50
" 314—Pool's Signal Service Barometer, Varnished Wood Backs, Cove Moulded Edges	"	3.55
" 78—Mounted on Carved Oak Back, Fine Polish, Etched Bottle	"	0.10

Each in a separate box, one dozen in a large box.

BRICK TROWELS



LONDON PATTERN

Size	10	10½	11	11½	12	13	13½	14 inch.
Disston's..... per doz.	\$.....	13.15	13.75	14.40	15.00	16.00	17.80	18.75
Brades', No. 2880..... "	12.50	12.75	13.10	13.50	14.30	14.75	15.20
" N. Y., No. 2155..... "	11.00	11.50
Boker's, No. 1010½..... "	4.75	5.00	5.30	5.50
" " 1000..... "	2.00



PHILADELPHIA PATTERN

Size	11	11½	12	12½	13	14 inch.
Disston's..... per doz.	\$.....	16.25	16.90	17.80	18.75
Wm. Rose & Bros..... "	20.00	20.65	21.35	22.00	22.75	24.15

STONEMASONS' TROWELS

Brades', No. 2150, 8½ inch..... per doz. \$8.20

POINTING TROWELS



GAUGING TROWELS



Size	4½	5	5½	6	7	8 inch.
Disston's, Pointing Trowels..... per doz.	\$.....	5.95	6.25	6.55
Brades' " "..... "	5.60	6.10	6.65
Boker's, No. 1610½, Pointing Trowels..... "	2.65	2.75	2.85	3.00
" " 1624 Gauging Trowels..... "	5.10	5.70	6.90

PLASTERING TROWELS



Size.....		11	11½	12 inch.
Diaston's, No. 1.....	per doz.	\$15.25	10.75	18.50
" " 2.....	"	13.50	14.50	15.75
Cincinnati (Woodrough & McParlins').....	"	10.50	20.25	21.00
Shurly & Dietrich, No. 1, Silver Steel.....	"	18.00	10.00	20.00

MASONS' MITRE RODS

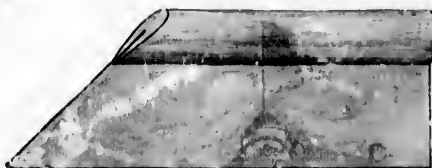

No. 1—With Back.....	per inch face	\$0.10
" 2—Without Back.....	" "	0.07

TUCKING JOINTERS



No. 3—Tucking Jointers, without Handles.....	per doz.	7.00
--	----------	------

BRICK HAMMERS



No. 4—Brick Hammers, Solid Steel, 8 inch Handles.....	per doz.	15.00
" 5— " Scrutches (similar to Hammer, but with two "Cutter" Ends).....	"	15.00

HANDLES

ADZE EYE HAMMER HANDLES



MACHINISTS' HAMMER HANDLES



Adze Eye Hammer Handles, Selected Second Growth Hickory.....	per doz.	\$0.75					
" " Extra Hickory.....	"	0.50					
Length.....			14	16	18	20	22 inch,
Machinist's Hammer Handles, Selected Second Growth Hickory.....	per doz.	\$0.85	1.00	1.15	1.30	1.45	24 inch,
" " Extra Hickory.....	"	0.00	0.70	0.80	0.65	1.00	1.15

SLEDGE HANDLES



Length.....			30	32	34	36	40 inch.
Selected Second Growth Hickory.....	per doz.	\$2.00	2.25	2.50	2.75	3.40	
Extra Hickory.....	"	1.00	1.75	2.00	2.25	2.75	

HATCHET HANDLES



BENCH AXE HANDLES



Length.....			14	15	16	17 inch.
Shingle and Lath Hatchet Handles, Selected Second Growth Hickory ..	per doz.	\$0.75	0.75
Bench Axe Handles, Selected Second Growth Hickory	"	..	0.90	0.90	0.90	

AXE HANDLES



No. A - Selected Second Growth Hickory, 30 inch	per doz.	\$4.00
" B - Extra " " 30 "	"	3.00
" C - Special No 1, " " 30 "	"	2.00
" D - " 2, " " 30 "	"	1.50
" E - Boys, No. 1, Hickory, 28 "	"	1.25
" F - Best Second Growth Oak, 30 "	"	3.00
" G - Octagon No. 1 Hickory, Hand Shaved, 30 inch	"	2.00
" H - " Extra " " 30 "	"	3.00
" K - " Selected Second Growth Hickory, Hand Shaved, 30 inch	"	4.00
" M - Oval, " " " " 30 "	"	4.00

DOUBLE BITTED AXE HANDLES



Double Bitted Axe Handles, Selected Second Growth Hickory, 30 inch.....	per doz.	\$3.50
" " " " 40 "	"	4.00
Broad Axe Handles, Right or Left Hand Pattern, Selected Second Growth Hickory.....	"	2.50

HANDLES

ADZE HANDLES



House Carpenters' Adze Handles, Selected Second Growth Hickory per doz. \$2.00



Railroad or Ship Carpenters' Adze Handles, Selected Second Growth Hickory per doz. 2.00

RAILROAD, OR SURFACE PICK HANDLES



Pick or Mattock Handles, Selected Second Growth Hickory, 30 inch per doz. 4.00
 " " " Extra Hickory, 30 inch " 2.50
 " " " No. 1 Hickory, 30 " " 2.00

DRIFTING PICK HANDLES



Used entirely for mining purposes.

Drifting Pick Handles, Selected Second Growth Hickory, 34 inch per doz. 3.25
 " " " Extra Hickory, 34 inch " 2.25

MINERS' POLL PICK HANDLES



Poll Pick Handles, Selected Second Growth Hickory, 34 inch per doz. 3.25

HAND SAW AND PLANE HANDLES



SAW



No. 10



No. 12

No. 3—Hand, Panel and Rip Saw Handles, Plain per doz. \$1.15
 " 2— " " " Varnished " 1.30
 " 7— " " " " for No. 7 Hand Saw " 3.40
 " D8— " " " " " D8 " " 5.40
 Compass Saw Handles " 1.05
 No. 10—Jack Plane Handles " 0.45
 " 12—Jointer " " 0.80

One dozen in a box.

CHISEL HANDLES

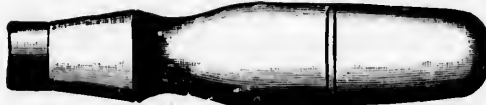

TANGED FIRMER				SOCKET FIRMER	
No. 31	Tanged Firmer Chisel Handles, Hickory, Brass Ferrule, Assorted, 6 sizes			per gross	\$ 5.20
" 36	" " " " " " " " " "			6 large sizes	7.20
" 37	" " " " " " " " " "			extra large	8.80
" 38	" " " " " " " " " "			largest size made	10.40
" 41	" " " " " Applewood			Assorted, 6 sizes	6.40
" 46	" " " " " " " " " "			large size only	8.00
" 47	" " " " " " " " " "			extra large size only	9.60
" 48	" " Carving			about 4 x 1/2 inch	8.00
" 61	Socket Firmer			Assorted, 6 sizes	5.20
" 66	" " " " " " " " " "			large sizes only	6.80
" 67	" " " " " " " " " "			extra large sizes only	8.00

TANGED FIRMER CHISEL HANDLES



No. 210



211



212 and 212 1/2



213 and 213 1/2



214



215 and 215 1/2

BOXWOOD

Nos.	210	211	212 1/2	213 1/2	214	215 1/2
In sets of 12, for Chisels 1/4 to 2 inch... per set	\$2.15	2.90	3.55	3.05	2.65	3.55

BEECHWOOD

Nos.	212	216	215
In sets of 12, for Chisels 1/4 to 2 inch... per set	\$1.00	1.00	1.60

SOCKET FRAMING CHISEL HANDLES



No. 71	Socket Framing Chisel Handles, Hickory, Assorted, 6 sizes	per gross	\$6.80
--------	---	-----------	--------

RAWHIDE CAP CHISEL HANDLES

No. A	Tanged Firmer Chisel Handles, Hickory, Brass Ferrules, Assorted, 5 sizes	per gross	\$15.40
" B	" " " " " " " " " " 2 large sizes	"	16.80
" AA	Socket " " " " " " " " " " Assorted, 5 sizes	"	15.40
" CC	Framing " " " " " " " " " " one size	"	18.20

One dozen in a box.

TURNSCREW HANDLES

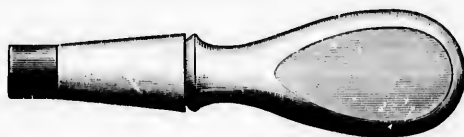

Beechwood, with Heavy Capped Ferrules, Drilled and Slotted.

Size for.....	5	6	8	10	inch.
No. 62	per doz.	\$0.75	0.05	1.20	1.75
" 1380 —Marples' Varnished Beechwood, Assorted for 5, 6, 7 and 8 inch.....					per doz. \$2.25

One dozen in a box.

FILE HANDLES



No. 121 —Basswood File Handles, Assorted, 4 sizes.....					per gross 2.40
" 123 — " " " " 2 larger sizes.....					" 2.85

Quarter gross in a box.

BRAD AWL HANDLES



No. 1373 —Marples' Oval Brad Awl Handles, Beechwood Varnished, Brass Ferrule, Assorted.....					per gross 6.00
--	--	--	--	--	----------------

AWL HAFTS



No. 51. PEG AWL HAFT



No. 46, SEWING AWL HAFT



No. 21, SEWING AWL HAFT

No. 51 —Peg Hafts, Leathered Top.....					per doz. \$0.00
" 46 —Sewing " Short Nut.....					" 0.00
" 21 — " " Brass Ferrule.....					" 0.50

AUGER HANDLES



No. 1

No. 1—Plain Auger Handles, assorted..... per doz. \$0.50

IVES' PATENT AUGER HANDLES



No. 2

No. 3

Will hold any size Auger.

No. 2—In Sets of two Handles (large and small)	per set	\$1.90
“ 2½—Handles separate	each	1.25
“ 3—Millwright, in sets of two Handles (large and small)	per set	2.50
“ 3½— “ “ Handles separate	each	1.60

No. 3 has adjustable “Cam Ring,” as shown in cut of No. 2.

SEAMLESS BRASS FERRULES



Nos. 7	6	4	2	0							
Nos. 10	9	7	6	5	4	3	2	1	0	00	
Inside diameter	$\frac{1}{2}$	$\frac{3}{8}$	$\frac{1}{2}$	$\frac{5}{8}$	$\frac{1}{2}$	$\frac{3}{4}$	$\frac{1}{2}$	$\frac{1}{2}$	$\frac{1}{2}$	$\frac{1}{2}$	1 inch.
Per gross	\$0.30	0.33	0.47	0.60	0.65	0.80	0.85	1.00	1.10	1.25	1.65

COLVIN INTERCHANGEABLE MALLETS

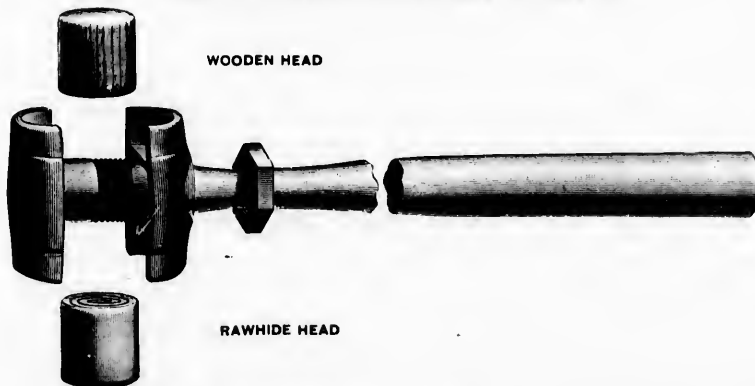

WOODEN HEAD

RAWHIDE HEAD

No. 3—With two Rawhide Heads, $1\frac{1}{2}$ inch diameter, weight $1\frac{1}{4}$ lbs.....	each	\$2.25
“ 4— “ “ “ “ “ 2 “ “ “ 3 “	“	3.00
“ 3—Heads only	“	0.45
“ 4— “	“	0.65

A Rawhide Head can be used on one side, with a Wooden, Copper or Hard Rubber Head on the other. Workers in copper, tin and other soft metals find them indispensable.

TOOL BASKETS



Size.....	Medium	Large	Extra Large.
Bound.....	30	33	36 inches.
Bound and Lined.....	\$3.00	3.75	4.80
	5.10	5.50	6.75

GIANT NAIL PULLERS



No. 1—American, Large, length 18 inches.....	per dozen	\$24.00
" 2— " Small, length 15 inches.....	"	20.00
" 1362—Boker's Giant Pattern.....	"	13.50
" 1359— " Pattern.....	"	12.60

BOX OPENING CHISELS



No. 72—12 inch Japanned, Wrought Iron, Steel Faced.....	per dozen	\$4.80
	Half-dozen in a box.	

CAST STEEL COLD CHISEL



Size.....	$\frac{3}{8}$	$\frac{1}{2}$	$\frac{5}{8}$	$\frac{3}{4}$	$\frac{7}{8}$	1 inch.
Per dozen.....	\$0.85	1.25	2.10	2.60	3.05	4.50
	Half-dozen in a box.					

BOX SCRAPERS.

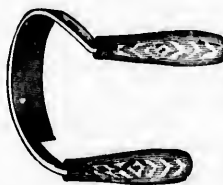

No. 11— $5\frac{1}{2}$ inch Oval Cut, Forged.....	per dozen	\$0.80
---	-----------	--------

METALLIC PATTERN LETTERS AND FIGURES

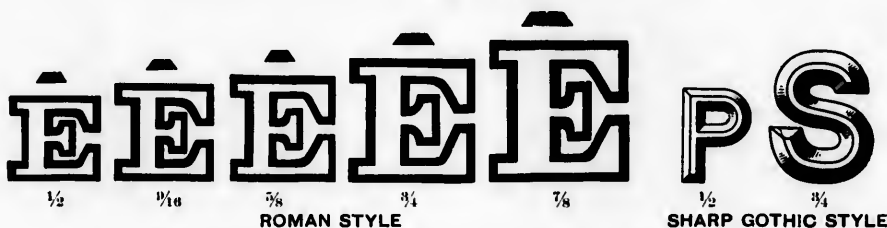

Measure on face, a $\frac{1}{8}$ inch Letter or Figure will measure $\frac{7}{8}$ inch on the back.

Size	$\frac{3}{16}$	$\frac{1}{4}$	$\frac{5}{16}$	$\frac{3}{4}$	$\frac{1}{2}$	$\frac{5}{8}$	$\frac{3}{4}$	1
Each	\$0.02	0.02	0.02	0.02 $\frac{1}{2}$	0.02 $\frac{1}{2}$	0.03	0.03 $\frac{1}{2}$	0.04 $\frac{1}{2}$

To fasten the Letters or Figures to the Patterns, use a solution of gum shellac and alcohol.

STEEL MARKING LETTERS AND FIGURES



Size	$\frac{1}{16}$	$\frac{1}{8}$	$\frac{3}{16}$	$\frac{1}{4}$	$\frac{5}{16}$	$\frac{3}{4}$
Steel Marking Letters	\$4.40	4.40	5.40	0.75	8.10	10.80
“ Figures	1.50	1.50	1.80	2.25	2.70	3.60
Name Stamps	0.20	0.20	0.30	0.35	0.40	0.50

50 cents per pound additional for Forgings on all Stamps with lettering over $\frac{3}{8}$ inch.

STENCIL ALPHABET AND FIGURES IN SETS



In separate pieces or made on strips.

Size	$\frac{1}{2}$	$\frac{3}{4}$	1	$1\frac{1}{4}$	$1\frac{1}{2}$	2	$2\frac{1}{2}$	3	4
Letters	\$0.55	0.70	1.10	1.35	1.70	2.70	3.40	4.05	5.40
Figures	0.30	0.35	0.40	0.55	0.70	1.00	1.20	1.35	2.70

Alphabet and Figures, Circular, 25 per cent. extrm. Straight Line Business Stencils, $\frac{1}{2}$ inch, 2 $\frac{1}{2}$ cents; $\frac{3}{4}$ and 1 inch, 4 cents; $1\frac{1}{4}$ inch, 5 $\frac{1}{2}$ cents per letter.

PUNCHING PRESSES

Will punch $\frac{1}{4}$ inch round hole in iron $\frac{1}{4}$ inch thick, or
 $\frac{1}{8}$ inch round hole in iron $\frac{1}{4}$ inch thick.
 It will punch as far as $1\frac{1}{2}$ inches from edge of the work.



No. 1

Supplied with Punches and Dies, 1-8, 3-16 and 1-4 inch. Unless otherwise ordered, Punches and Dies will be supplied 1-32 inch over exact sizes. Weight 80 lbs.

Complete..... \$37.50

Extra Punches or Dies, 75 cents each.

The handle may be set at any angle, up or down, to suit various kinds of work.

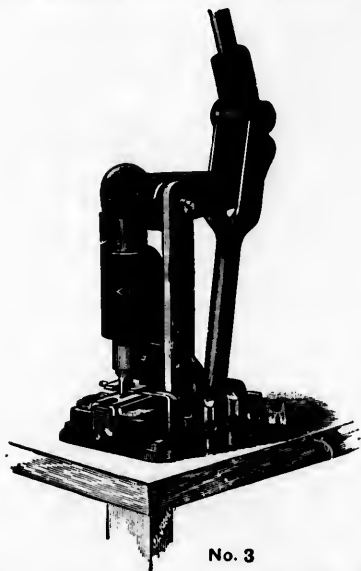

No. 3

Complete, with four Round Punches and Dies.. \$14.00
 Complete, with 4 Punches and Dies for Saw Gunning 15.00
 Machine, without Punches or Dies..... 9.00
 Round Punches or Dies..... each 0.65
 Saw Gunning Punches or Dies..... " 0.90

Saw Gunning Punches and Dies are 1-8x7-8, 3-16x7-8, 1-2x7-8, 5-8x7-8, and Round Punches from 1-8 to 3-8. 1-32 oversize sent unless otherwise ordered.



No. 2

Will punch 1-2 inch hole in iron 5-16 inch thick as far as 3 1-8 inches from edge of work.

For convenience in using the larger sizes of Punches and Dies the ratchet may be brought into play by throwing in the dog. Two handles. Prices with Punches and Dies:

No. 622—Machine with sizes $\frac{1}{4}$, $\frac{1}{8}$, $\frac{3}{16}$ inch..... \$67.50
 " 623— " " " $\frac{1}{8}$, $\frac{1}{16}$, $\frac{1}{32}$, $\frac{1}{64}$, $\frac{3}{16}$ inch... 71.25

Extra Punches, 75 cents each; Dies, \$1.15 each.

Weight, 250 lbs.

Unless otherwise ordered, Punches and Dies will be supplied 1-32 inch over exact sizes.

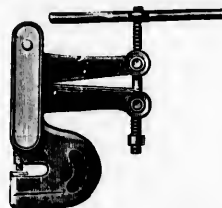

OPEN MOUTH DUPLEX BEAR PUNCH

Forged Steel Body, Steel Joint Pins, Screws and Nuts, with one 3-4 Round Steel Punch and Die.

No. 2 —Centre of Punch to back $1\frac{1}{2}$ inch...each \$37.00
 " 2A— " " " 2 " " " 45.35

No. 2 weighs about 50 lbs., and No. 2A about 75 lbs.

TIRE BENDERS



No. 5

This machine will take tires up to 4 in. in width; is an excellent machine for light work, will bend $1\frac{1}{2}$ x $\frac{1}{2}$ in. easily. The centre roller may be removed after bending the tire, or to admit a welded tire. It is strongly geared, and has change of speed for light and heavy work.

No. 5—Weight 65 lbs.....each \$8.00

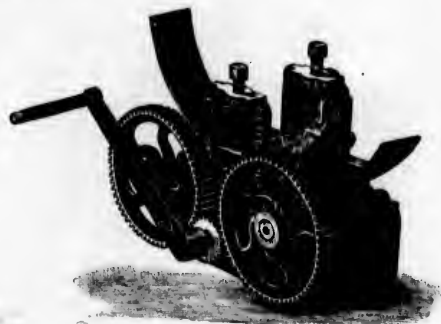

No. 2

Is strongly geared and will bend tires up to 4 in. in width. Has a change of speed for light and heavy tires. The middle roller is removable to take out tire after bending, or to round up a tire after welding.

No. 2—Weight 120 lbs.....each \$9.50

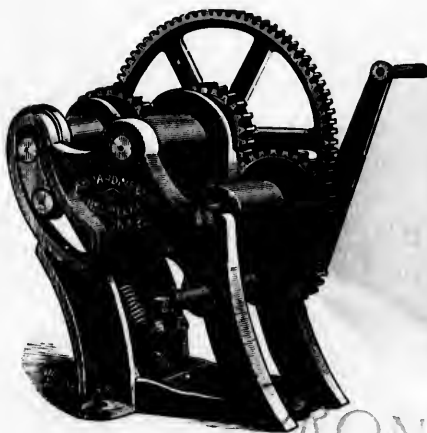

No. 4

No. 4

Has all three rollers geared, a most desirable feature in a bender for heavy tires, or for bending circles. The rollers are grooved for two thicknesses of iron for circles. Unless otherwise ordered we send with grooves for $\frac{3}{4}$ and $\frac{1}{2}$ in.

This machine bends tires up to 4 x 1 in., and any lighter size; also iron up to $1\frac{1}{2}$ x $\frac{3}{4}$ edgewise for circles. The top roller can be taken out to admit welded tire, or to take out the tire or circle after bending.

No. 4—Weight 220 lbs.....each \$30.00

Countershaft, etc., to suit this machine, \$25.00 extra.

IMPROVED TIRE UPSETTER

No. 1—Upsets tires up to 2 in. wide.....each \$11.50

" 2—Upsets tires up to 4 in. wide..... " 13.50



Nos. 1 and 2

PUNCH AND SHEARS

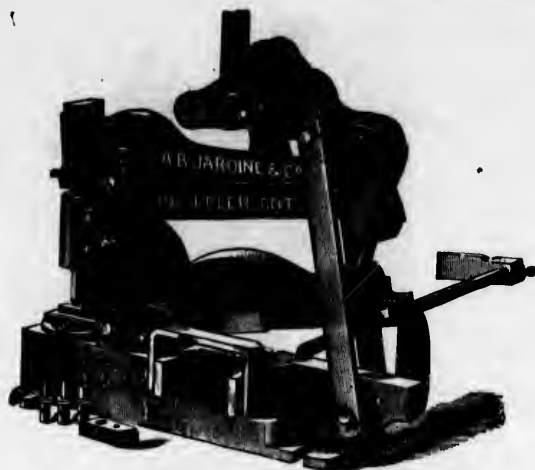

No. 1

No. 1

This Machine shears up to $\frac{3}{4}$ inch square and thinner iron up to 4 inch wide. It will punch $\frac{7}{8}$ hole in $\frac{1}{2}$ iron or $\frac{3}{4}$ hole in $\frac{3}{4}$ iron. Weight, 250 lbs.

Price with four Round Punches and Dies... \$27.00
 Round Punches.....each 0.75
 " Dies..... " 0.75

HAND SHEAR

No. 2

This Shear will cut off iron to $\frac{3}{4}$ square, or $1\frac{1}{2} \times \frac{1}{2}$ inch. It is especially designed to meet the wants of a general blacksmith, and is handy and convenient, as well as durable and strong. It is provided with a fence or stop for convenience in cutting a number of pieces the same length, and a bar to prevent the iron from rising or twisting while being cut. The knives are of the best cast steel, and are adjustable for wear. Weight, 160 lbs.

Price..... \$16.00



No. 2

TUYERE IRONS AND BACKS

Price.....per lb. 6c.



DUCK'S NEST

DUCK'S NEST TUYERE IRONS

Price.....each \$1.25



TUYERE IRON BACK

BLACKSMITH TOOLS

FOOT VISES

FOR SHARPENING HORSESHOES



No. 2

With a Square Base to be bolted to the floor.

With one of these Vises you can do better work than on the anvil, and in less than half the time.

No. 2 weighs 100 lbs.

Priceeach \$7.50

TAPER MANDREL AND SWAGE BLOCKS



MANDREL

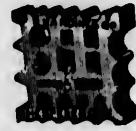

SWAGE BLOCK

Swage Blocks, 12 $\frac{1}{2}$ x 12 $\frac{1}{2}$ x 4 $\frac{1}{2}$ inch.

Rougheach \$6.00
Planned both sides..... " 7.00

Taper Mandrel, 12 inch diameter at base, 2 $\frac{1}{2}$ inch at top, 48 inch high, with groove the whole length of Mandrel.

Each \$8.00

BOLT CLIPPERS

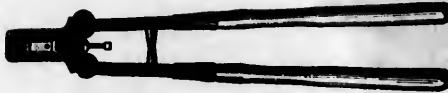

Nos.....	0J	1J	2J	3J
For Bolts	$\frac{1}{8}$	$\frac{1}{4}$	$\frac{1}{2}$	$\frac{3}{4}$ inch.
Each.....	\$3.35	4.05	5.70	7.25

Nos.....	0	1
For Bolts	$\frac{1}{4}$	$\frac{1}{2}$ inch.
Each.....	\$4.75	6.25



No. 2—Porter's Easy Bolt Clippers, length 30 inches, for Bolts $\frac{1}{4}$ inch.....each \$ 8.75
" 3— " New Easy Bolt Clippers, " 30 " " " $\frac{1}{2}$ " " 11.25

Nos. 0 and 3 are the "New Easy" Clippers, adjusted by a Steel Set-Screw in each adjusting section. Nos. 1 and 2 are the "Easy" Clippers, adjusted by Shims.

PORTABLE FORGES



LEADER FORGE, No. 12



HERO FORGE, No. 7

LEADER FORGE, No. 12

Suitable for Light Work. 0070

Hearth 18 inch, Height 30 inch, Weight 65 lbs.

No. 12—Half Hood.....each \$16.00
 " 11—Shield....." 14.00

HERO FORGE, No. 7

Suitable for Mine and Tool Making. 0070

Hearth 18 inch, Height 30 inch, Weight 75 lbs.

No. 7—Half Hood.....each \$23.00
 " 6—Shield....." 20.00

CHALLENGE FORGE, No. 5

Capacity for Heating 2 inch Iron. 7070

Fan 9½ inch, Hearth 22 inch, Height 33 inch, Weight 90 lbs.

No. 5—Half Hood.....each \$27.00
 " 4—Shield....." 24.00



CHALLENGE FORGE, No. 5

PORTABLE FORGES



CHALLENGE FORGE, No. 3



WESTERN CHIEF FORGE, No. 5



WESTERN CHIEF FORGE, No. 3

LEWIS & SONS
LIMITED

TORONTO, ONT.

CHALLENGE FORGE, No. 3

Capacity for heating 3 inch iron.

Fan 12 1/2 inch, Hearth 35 x 23 inch, Height 30 inch,
Weight 130 lbs.

No. 3—Half Hood.....each \$40.00
" 2—Shield....." 30.00

2070

WESTERN CHIEF FORGE, No. 5

Capacity for heating 2 inch iron.

Fan 9 inch, Hearth 22 inch, Height 33 inch, Weight
100 lbs.

No. 5—Half Hood.....each \$27.00
" 4—Shield....." 24.00

02070

WESTERN CHIEF FORGE, No. 3

Capacity for heating 3 inch iron.

Fan 12 inch, Hearth 35 x 23 inch, Height 30 inch,
Weight 145 lbs.

No. 3—Half Hood.....each \$40.00
" 2—Shield....." 30.00

02070

PORTABLE FORGES



CHALLENGE FORGE, No. 1

This Forge has improved Fire Pot separate from Hearth. Fan 14½ inch, Hearth 45×31 inch, Height 30 inch, Length over all 53 inch, Weight 200 lbs.

Without Water Tankeach \$50.00
 With " " " 55.00



WESTERN CHIEF FORGE, No. 1

This Forge has Brass Boxes and Oil Cups. Fan 14½ inch, Hearth 46×33½ inch, Height 30 inch, Length over all 54 inch, Weight 300 lbs.

With Coal or Water Tank.....each \$50.00
 With extra " " " 55.00

BLAST GATES

FOR OPENING AND CLOSING PIPES WHICH SUPPLY BLAST TO FURNACES,
 FORGES, ETC.

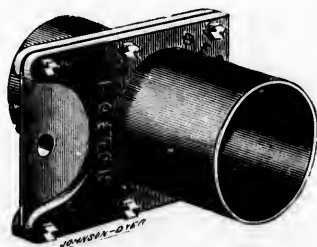

Size	2	2½	3	4	5	6	8	10	12	14	16 inch.
Each	\$1.25	1.55	1.90	2.50	2.70	3.15	4.40	6.25	8.15	10.00	15.00

These measurements apply to the outside of the Collars of the Blast Gate.

WESTERN CHIEF BLOWERS

2170

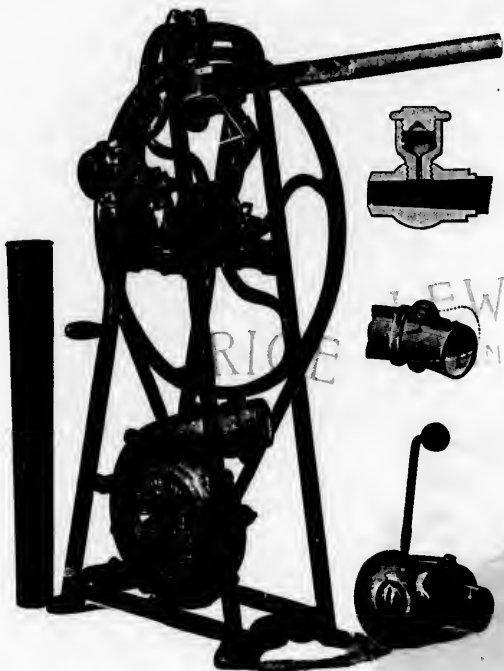

Size D

WESTERN CHIEF BLOWER SIZE D

With Crank and Lever Movement.
Fan 14½ inch, Fly-wheel 27 inch.

Each..... \$28.50

With Brass Boxes and Oil Cups and Reversible Nose to Fan Case.



Size E

WESTERN CHIEF BLOWER SIZE E

Lever Movement only.
Fan 14½ inch, Fly-wheel 27 inch.

Each..... \$23.50

With Brass Boxes and Oil Cups and Reversible Nose to Fan Case.

2070
Each \$50.00
53.00

8 Inch.
00

BLACKSMITH BELLOWS

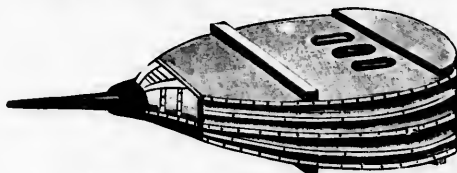

WESTMAN'S DOMINION PATTERN

This is a very easy working Bellows. With the three valves as shown in the engraving, and the peculiar shape of the bellows box, it will shut and open quickly, giving a greater and steadier blast than the ordinary kind.

Size.....	28	30	32	34	36	38	40 inch.
Each.....	\$17.00	18.00	22.00	24.00	28.00	32.00	36.00

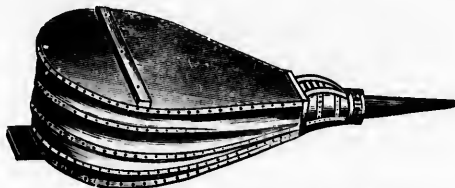

WESTMAN'S ORDINARY PATTERN

Size.....	24	26	28	30	32	34	36	38	40 inch.
No. 1—Westman's Ordinary Pattern..... each	\$10.00	11.00	\$14.00	15.00	16.00	17.00	18.00	22.00	26.00
Standard Pattern.....			12.00	13.00	14.00	16.00	18.00	20.00
extra long.....			\$15.00	17.00	19.00	21.00	24.00



STANDARD PATTERN

The Extra Long Bellows are made considerably longer than the Standard and have likewise a greater spread of leather. They are well adapted for ordinary blacksmith work.

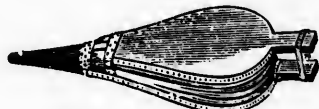

MOULDERS' BELLOWS

Nos.....	1	2	3
Greatest width.....	6	8	10 inch.
Per dozen.....	\$11.25	13.15	16.00



HAND BELLOWS

Fancy Leather, Brass Tube.

Size.....	16 x 6	18 x 7 inch.
No. 3141..... per doz.	\$3.85	4.05

COUNTERSHAFTS FOR STEEL PRESSURE BLOWERS

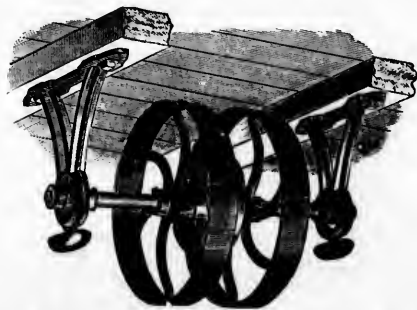

Nos. 1 to 6 regularly have but one driving pulley; Nos. 7 to 12 have two driving pulleys. Additional pulleys, also tight and loose pulleys, may be furnished on these counter shafts at a small additional price.

Number of Steel Pressure Blower	Diameter of Pulley Driving Power.	Diam. of Pulley Driven by Main Belt from Line Shaft.	Diameter of Shaft.	Price with One Driving Pulley.	Price with Two Driving Pulleys.
1	12	4	1/2	\$ 8.00	
2	14	5	1	10.00	
3	16	6	1 1/4	12.00	
4	18	7	1 1/2	16.00	
5	21	8	1 3/4	20.00	
6	25	10	2	25.00	
7	30	12	2 1/2	30.00	\$ 35.00
8	32	12	2	40.00	45.00
9	36	14	2 1/2	50.00	60.00
10	40	16	2 3/4	70.00	80.00
11	42	17	2 3/4	80.00	90.00
11 1/2	44	18	3	90.00	100.00
12	44	18	3	100.00	110.00

THE BUFFALO STEEL BLOWERS AND EXHAUSTERS

Nos. 1 to 6 Blowers, inclusive, have one pulley, and Nos. 7 to 12 have two pulleys.

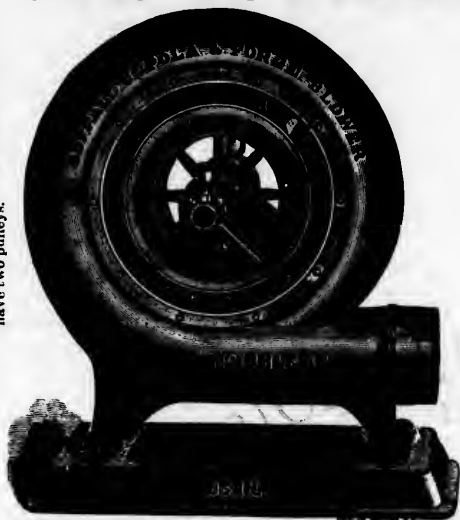

**PRESSURE BLOWER
FOR CUPOLA AND FORGE FIRES**

Number of Blower.	Height in Inches.	Diameter of Outlet.	Diameter of Pulley.	Face of Pulley.	Price without Countershaft.	Price with Countershaft.	ADJUSTABLE BED.	
							Price with Bed but without Countershaft.	Price with Bed and with Countershaft.
1	12½	3½	2½	1¾	\$12.00	\$20.00		
2	15	4	2½	2	18.00	28.00		
3	20	4½	3½	2½	20.00	38.00		
4	24	5½	4	3	30.00	52.00		
5	26	5½	4½	3	44.00	64.00		
6	30	6½	4½	3½	55.00	80.00		
7	35	7½	5	4½	70.00	100.00	\$100.00	\$135.00
8	40	8½	6	4½	100.00	130.00	130.00	175.00
9	45	10	7	5	115.00	170.00	170.00	230.00
10	50	12½	8	5½	100.00	230.00	205.00	350.00
11	60	14½	9	6½	225.00	300.00	330.00	435.00
11½	70	16½	10	7	275.00	350.00	380.00	500.00
12	80	18	10	8	325.00	400.00	475.00	625.00



STYLE "B" BLOWERS AND EXHAUSTERS

FOR FORGES, FURNACES, VENTILATING, DRYING AND COOLING

No. of Blower or Exhauster.	Height in Inches.	Diameter of Outlet.	Diameter of Inlet.	Diameter of Pulley.	Face of Pulley.	Price.
000B	14½	4½	4½	2½	2½	\$ 15.00
1B	15½	5	5	3	2½	20.00
2B	20½	6	6	3½	2½	25.00
3B	25	7½	7½	4	3½	33.00
4B	29	9	9	5	4	44.00
5B	32	10½	10½	5½	4½	55.00
6B	37½	12	12	6½	5½	70.00
7B	43	14	14	7½	6½	90.00
8B	48	16½	16	8½	7½	150.00
9B	55	18	18	9½	8½	200.00
10B	68	21	21	12	10	250.00
11B	70	24	24	14	12	350.00

BUFFALO STEEL PLATE PLANING MILL EXHAUSTERS WITH OVERHUNG WHEELS

Sizes.	Diameter Inlets.	Size of Outlets.	Single Fan Pulleys		Price of Single Fans.	Double Fan Pulleys.		Price of Double Fans.
			Diam.	Face.		Diam.	Face.	
30-in.	11½	9½ x 9½	6	4½	\$55.00	8	7	\$60.00
35 "	13½	11½ x 11½	7	5½	70.00	9	8	100.00
40 "	14½	13½ x 13½	8	6	90.00	10	9	130.00
45 "	17½	15 x 15	9	6½	115.00	11	9½	170.00
50 "	19	16½ x 16½	10	7	150.00	12	10	210.00
55 "	20	18 x 18	11	8	185.00	13	11	275.00
60 "	22½	19½ x 19½	11½	9	200.00	14	12	325.00
70 "	24½	22 x 22	12	10	250.00			
80 "	30½	20 x 20	14	10½	300.00			

Right hand bottom horizontal discharge exhauster is shown in cut. We can furnish them with left hand bottom horizontal discharge, right or left hand top horizontal discharge, up or down blast.



Similar shape of ind.
40 inch.
36.00



40 inch.
26.00
.....
.....
water spread



18 x 7 inch.
4.65

Price with Two Driving Pulleys.

\$ 35.00
45.00
60.00
80.00
100.00
110.00

COTTON BELTING

SUITABLE FOR ELEVATORS AND ALL KINDS OF OPEN BELT DRIVING PURPOSES

Price per Running Foot



2-Ply		3-Ply		4-Ply		5-Ply		6-Ply	
Width	Price	Width	Price	Width	Price	Width	Price	Width	Price
1 in.	\$0.04	1½ in.	\$0.07	2 in.	\$0.12	4 in.	\$0.34	6 in.	\$0.40
1½ "	0.05	2 "	0.09	2½ "	0.14	4½ "	0.36	7 "	0.51
2 "	0.06	2½ "	0.11	3 "	0.16	5 "	0.38	8 "	0.57
2½ "	0.07	3 "	0.13	3½ "	0.18	5½ "	0.40	9 "	0.60
3 "	0.08	3½ "	0.15	4 "	0.21	6 "	0.42	10 "	0.75
3½ "	0.09	4 "	0.16	4½ "	0.24	7 "	0.45	12 "	0.90
4 "	0.10	4½ "	0.18	5 "	0.26	8 "	0.50	14 "	1.12
4½ "	0.12	5 "	0.20	5½ "	0.28	9 "	0.56	16 "	1.35
5 "	0.14	5½ "	0.22	6 "	0.30	10 "	0.63	18 "	1.50
5½ "	0.16	6 "	0.24	6½ "	0.34	11 "	0.75	20 "	1.72
6 "	0.18	6½ "	0.26	7 "	0.38	12 "	0.84	22 "	1.94
6½ "	0.20	7 "	0.28	7½ "	0.42	13 "	0.94	24 "	2.16
7 "	0.22	7½ "	0.32	8 "	0.44	14 "	1.12		

DETACHABLE



LINK BELTING

No.	Price per foot		Links per foot	Working Strain.	No.	Price per foot.		Links per foot.	Working Strain.	No.	Price per foot		Links per foot.	Working Strain.
	Plain.	Attach-ments.				Plain	Attach-ments				Plain.	Attach-ments.		
25	\$0.13	\$0.38	13.3	75 lbs.	54	\$0.22	8.2	475 lbs.	83	\$0.45	\$0.90	3.	1,200 lbs.
32	0.13	0.36	10.4	150 "	055	0.24	7.4	525 "	85	0.50	0.90	3.	1,300 "
33	0.12	0.35	8.0	200 "	55	0.22	\$0.37	7.4	450 "	88	0.50	0.90	4.6	1,200 "
34	0.13	0.35	8.0	225 "	57	0.24	0.47	5.2	900 "	89	0.60	4.6	1,300 "
35	0.14	0.32	7.4	250 "	58	0.24	7.5	550 "	93	0.60	1.20	3.	1,600 "
36½	0.16	8.	250 "	62	0.30	0.55	7.25	650 "	95	0.60	1.20	3.	1,600 "
37	0.16	0.38	0.	225 "	64	0.30	8.	550 "	101	0.60	1.20	4.5	1,600 "
38	0.16	0.35	0.	250 "	65	0.30	0.53	5.06	550 "	103	0.75	1.20	4.	1,800 "
42	0.16	0.35	8.75	300 "	66	0.30	0.53	6.	700 "	105	0.70	1.20	2.	1,500 "
44	0.16	0.35	8.1	325 "	67	0.30	0.53	5.2	700 "	108	0.80	1.40	2.55	2,000 "
45	0.16	0.35	7.4	350 "	71½	0.35	5.0	900 "	114	1.10	1.40	3.66	2,000 "
45½	0.16	0.35	7.4	250 "	72	0.35	5.0	850 "	115	1.05	3.7	2,050 "
47	0.18	0.38	7.4	400 "	72½	0.40	7.25	925 "	117	1.05	3.7	2,150 "
48	0.16	0.35	0.	375 "	75	0.35	0.65	4.6	750 "	118	1.05	3.7	2,200 "
50	0.20	0.38	8.75	350 "	76	0.35	5.2	625 "	122	1.50	2.00	2.	2,200 "
51	0.20	0.38	10.4	375 "	76½	0.35	5.8	700 "	124	1.30	2.00	3.	2,250 "
052	0.24	8.	525 "	77	0.35	0.65	5.2	800 "	146	1.40	1.80	2.	2,800 "
52	0.25	0.38	8.	500 "	78	0.40	0.80	4.0	1,000 "	160	2.00	2.50	1.2	4,000 "

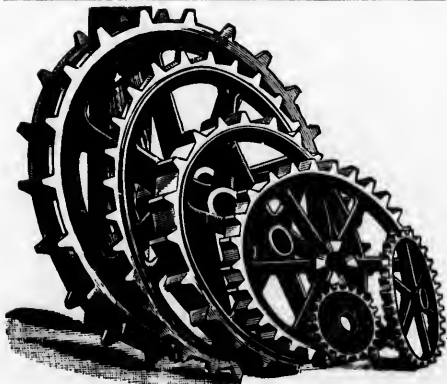

SPROCKET WHEELS TO FIT CHAIN BELTING

Prices on Application

In ordering, give Number of Chain, Number of Teeth, Diameter, Size of Hole, and, if required, Key-Seated or Set-Screwed.

American Leather
 1/2 inch wide up to 6' long
 1/2 inch wide up to 6' long
 1/2 inch wide up to 6' long
 1/2 inch wide up to 6' long

MACHINE BELTINGS

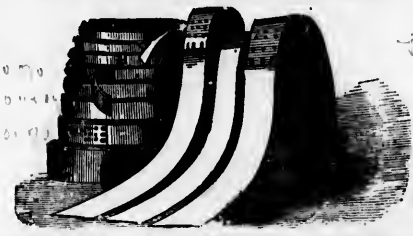

Machine Belting
 1/2 inch wide up to 6' long
 1/2 inch wide up to 6' long
 1/2 inch wide up to 6' long

Width	Price
6 in	\$0.40
7 "	0.51
8 "	0.57
9 "	0.66
10 "	0.75
12 "	0.90
14 "	1.12
16 "	1.35
18 "	1.50
20 "	1.72
24 "	1.94
30 "	2.16

LEATHER BELTING

RUBBER BELTING

PRICE LIST ADOPTED BY THE LEATHER BELTING MANUFACTURERS' ASSOCIATION

Width	A List Per foot	B List Per foot	Width	A List Per foot	B List Per foot
1 1/4 inch	\$0.10	\$0.12	28 inch	\$4.30	\$5.00
1 1/2 "	0.13	0.16	30 "	4.64	5.50
1 3/4 "	0.17	0.20	32 "	5.00	6.00
2 "	0.20	0.24	34 "	5.35	6.50
2 1/4 "	0.23	0.28	36 "	5.70	7.00
2 1/2 "	0.26	0.32	38 "	6.05	7.40
2 3/4 "	0.30	0.36	40 "	6.40	7.80
3 "	0.33	0.40	42 "	7.10	8.60
3 1/4 "	0.36	0.44	44 "	7.80	9.40
3 1/2 "	0.43	0.52			
4 "	0.50	0.60			
4 1/4 "	0.56	0.68			
4 1/2 "	0.63	0.76			
5 "	0.70	0.84			
5 1/2 "	0.76	0.92			
6 "	0.83	1.00			
6 1/2 "	0.90	1.08			
7 "	1.02	1.24			
8 "	1.15	1.40			
10 "	1.29	1.56			
11 "	1.42	1.72			
12 "	1.55	1.88			
14 "	1.82	2.20			
16 "	2.14	2.60			
18 "	2.49	3.00			
20 "	2.84	3.40			
22 "	3.20	3.80			
24 "	3.54	4.20			
26 "	3.92	4.60			

ROUND SOLID	
1/4 inch	5 cts.
1/2 "	7 cts.
3/4 "	10 cts.
1 "	14 cts.
1 1/4 "	18 cts.

TWIST	
1/4 inch	6 cts.
1/2 "	10 cts.
3/4 "	14 cts.
1 "	18 cts.
1 1/4 "	22 cts.
1 1/2 "	30 cts.
1 3/4 "	36 cts.
2 "	40 cts.
2 1/4 "	60 cts.
2 1/2 "	72 cts.

Width	2-Ply Per foot	3-Ply Per foot	4-Ply Per foot	5-Ply Per foot	6-Ply Per foot
1 inch	\$0.07	\$0.09	\$0.11		
1 1/4 "	0.09	0.11	0.13		
1 1/2 "	0.11	0.13	0.15	\$0.19	
1 3/4 "	0.13	0.15	0.17	0.21	
2 "	0.15	0.17	0.21	0.26	\$0.31
2 1/4 "	0.18	0.22	0.26	0.33	0.39
2 1/2 "	0.22	0.26	0.31	0.39	0.47
3 "	0.26	0.30	0.37	0.46	0.56
3 1/4 "	0.30	0.34	0.42	0.53	0.63
3 1/2 "	0.33	0.38	0.47	0.59	0.71
4 "	0.36	0.43	0.52	0.65	0.78
4 1/4 "	0.43	0.52	0.62	0.78	0.93
4 1/2 "	0.51	0.60	0.73	0.91	1.10
5 "	0.59	0.70	0.84	1.05	1.26
6 "	0.67	0.80	0.95	1.18	1.42
7 "	0.75	0.90	1.07	1.33	1.60
8 "	0.83	1.00	1.18	1.47	1.77
9 "	0.91	1.08	1.30	1.62	1.95
10 "	1.00	1.18	1.42	1.77	2.13
11 "	1.06	1.28	1.54	1.92	2.31
12 "	1.16	1.38	1.66	2.07	2.49
13 "	1.25	1.50	1.78	2.22	2.67
14 "	1.41	1.70	2.02	2.52	3.03
15 "	1.58	1.90	2.26	2.82	3.39
16 "	1.76	2.12	2.52	3.15	3.78
17 "	1.96	2.36	2.80	3.50	4.20
18 "	2.18	2.60	3.08	3.85	4.62
19 "	2.42	2.84	3.36	4.20	5.04
20 "			3.64	4.55	5.46
22 "			3.92	4.90	5.88
24 "			4.20	5.25	6.30
26 "			4.48	5.60	6.72
28 "			4.76	5.95	7.14
30 "			5.04	6.30	7.56
32 "			5.32	6.65	7.98
34 "			5.60	7.00	8.40
36 "			5.88	7.35	8.82
38 "			6.16	7.70	9.24

Double Belting twice the price of Single.
 In ordering, state where Bands are to run. We do not guarantee belts run on quarter turn, unless they are specially made for that purpose.

DISCOUNT

AMERICAN		CANADIAN	
Standard	Regular	No. 1	Standard
Light Double	Dynamo Double	Extra	Extra

DISCOUNT

Monarch	Red Strip	Lion

Endless Belts made to order. 3 feet extra charged for splice.

LACE LEATHER IN SIDES

Canadian Tanned	per lb.	\$0.90
Cocheco Raw Hide	per square foot	0.40

Side runs from 10 to 18 square feet.

CUT BELT LACING

Width		1/4	3/8	1/2 inch.
Canadian	per lb.	\$0.90	0.90	0.90
Cocheco Raw Hide	per 100 feet	0.85	1.25	1.75

One hundred feet in a package.

WOOD SPLIT PULLEYS



DIAMETER Inches	WIDTH OF FACE—Inches.														
	3	4	5	6	7	8	9	10	12	14	16	18	20	22	24
4	\$2.00	\$ 2.10	\$ 2.20	\$ 2.40	\$ 2.55	\$ 2.70	\$ 2.85	\$ 3.00							
5	2.10	2.20	2.35	2.55	2.70	2.85	3.00	3.15							
6	2.20	2.30	2.50	2.70	2.85	3.00	3.15	3.30							
7	2.30	2.40	2.65	2.85	3.00	3.15	3.30	3.45							
8	2.40	2.55	2.80	3.00	3.15	3.30	3.45	3.60							
9	2.50	2.65	2.90	3.15	3.28	3.40									
10	2.60	2.75	3.00	3.25	3.40	3.55	3.72	3.90							
11	2.70	2.85	3.10	3.35	3.53	3.70	3.90	4.10							
12	2.80	2.95	3.20	3.55	3.70	3.85	4.08	4.30	\$ 5.10						
13	2.90	3.10	3.40	3.75	4.00	4.25	4.53	4.80	5.00						
14	3.00	3.25	3.65	4.10	4.40	4.70	5.02	5.35	6.00	\$ 6.00					
15	3.10	3.45	3.85	4.35	4.75	5.10	5.48	5.85	6.50	7.20					
16	3.30	3.65	4.05	4.60	5.05	5.50	5.90	6.30	7.00	7.70					
17	3.50	3.85	4.25	4.85	5.35	5.85	6.30	6.70	7.50	8.25					
18	3.70	4.05	4.55	5.10	5.65	6.20	6.65	7.10	8.00	9.00	\$10.70				
19		4.25	4.80	5.50	6.18	6.75	7.15	7.50	8.60	9.80	11.70				
20		4.45	5.20	6.00	6.60	7.15	7.60	8.00	9.60	11.00	12.60				
21		4.70	5.60	6.40	6.90	7.50	8.10	8.65	10.40	12.00	13.70				
22		4.95	5.90	6.85	7.45	8.00	8.70	9.40	11.20	13.00	14.20				
23		5.20	6.15	7.05	7.70	8.40	9.20	9.95	12.00	14.00	16.00				
24		5.40	6.35	7.30	8.05	8.80	9.65	10.45	12.70	15.10	17.50				
25		5.80	6.65	7.60	8.40	9.20	9.85	10.60	13.40	16.25	19.10				
26		6.35	7.00	7.95	8.80	9.60	10.05	11.40	14.20	17.50	20.80	\$24.10	\$31.50	\$35.50	\$40.00
27		6.78	7.40	8.27	9.13	9.95	10.63	11.75	14.72	18.25	21.90	25.50	32.25	36.25	40.75
28		7.20	7.80	8.60	9.45	10.30	11.20	12.10	15.25	19.00	23.00	26.90	33.00	37.00	41.50
29		7.60	8.20	9.00	9.95	10.90	11.80	12.67	15.87	20.00	24.20	28.45	33.75	37.62	41.87
30		8.00	8.60	9.40	10.45	11.50	12.40	13.25	16.50	21.00	25.40	30.00	34.50	38.25	42.25
31		8.40	9.00	9.85	11.02	12.20	13.17	14.13	17.20	21.87	26.57	31.12	35.37	39.25	43.25
32		8.80	9.40	10.30	11.60	12.90	13.95	15.00	17.90	22.75	27.75	32.25	36.25	40.25	44.25
33		9.20	9.85	10.90	12.30	13.70	14.85	16.00	18.95	23.62	28.87	33.37	37.00	41.50	45.50
34		9.60	10.50	11.50	13.00	14.50	15.75	17.00	20.00	24.50	30.00	34.50	38.75	42.75	46.75
35		10.10	11.20	12.25	13.75	15.25	16.65	18.05	21.25	25.50	31.20	35.75	40.12	44.12	48.12
36		10.60	11.80	13.00	14.50	16.00	17.55	19.10	22.50	26.50	32.40	37.00	41.50	45.50	49.50
38		13.00	13.75	14.60	16.05	17.60	19.15	20.70	24.75	28.50	34.50	39.25	45.00	49.00	54.00
40		14.00	14.50	16.00	17.50	19.00	20.75	22.50	26.75	31.00	36.25	41.50	48.00	52.50	58.00
42		15.50	16.05	17.50	19.50	21.50	23.25	25.00	29.50	33.50	38.50	43.75	51.00	56.00	63.00
44		17.00	17.50	19.50	21.65	23.75	25.65	27.50	31.50	36.00	40.75	46.00	54.00	59.00	67.00
46		19.00	19.50	22.00	24.00	26.00	28.00	30.00	33.50	38.50	43.00	48.00	58.00	64.00	72.00
48		21.00	22.00	24.50	26.25	28.00	30.50	32.50	36.00	41.00	45.00	50.00	62.00	71.50	80.00
50				27.25	29.50	31.50	33.50	35.50	39.00	44.00	50.00	56.00	65.00	74.50	84.50
52					31.00	32.50	34.00	36.00	38.00	42.00	46.00	52.50	60.00	77.00	86.25
54					33.50	35.50	37.50	39.25	41.00	45.00	49.50	55.50	64.50	73.50	83.00
56					37.00	38.75	40.50	42.50	44.50	48.50	53.50	60.00	70.00	83.25	92.50
58					40.00	41.50	43.50	46.00	47.50	52.25	57.75	64.25	73.75	87.50	104.50
60					42.50	44.50	47.00	49.25	51.50	56.00	62.00	68.50	78.00	91.00	111.00

BELT TOOLS

COMBINED CUTTER, PUNCH AND AWL



No. 15—Length 5 inches, packed one in a box per doz. \$13.50



CUTTERS FOR BLAKE'S BELT STUDS

Large Cutters for Rubber Belts..... each \$1.95
 Small " " Leather " " 1.45

AWL AND PLIERS COMBINED FOR BLAKE'S BELT STUDS

Each..... \$0.65

ELLIOTT LACE CUTTERS



Price per doz. 7.25

WASHER CUTTERS



No C719 per doz. 14.20

22 24

35.50	\$40.00
36.25	40.75
37.00	41.50
37.62	41.87
38.25	42.25
39.00	43.25
40.25	44.25
41.50	45.50
42.75	46.75
44.12	48.12
45.50	49.50
49.00	54.00
52.50	58.00
56.00	63.00
59.00	67.00
64.00	72.00
71.50	80.00
74.50	84.50
77.00	86.25
83.00	92.50
88.25	102.50
95.25	104.50
101.00	111.00

BELT PUNCHES

THOS. ADAMS' BEST CAST STEEL



FULL SIZE OF HOLES	●	●	●	●	●	●	●	●	●	●	●	●
Size Nos....	1	2	3	4	5	6	7	8	9	10	11	12
Round Nos.....						1 to 6	7	8	9	10	11	12
Per dozen.....						\$1.65	1.85	2.10	2.50	2.85	3.50	3.95
Oval Nos.....			22		23	24	25	26	27	28	29	30
Per dozen.....			\$2.25		2.40	3.10	3.50	3.90	4.35	4.75	5.35	6.20



No. 910

Size Nos.....	2	3	4	5	6	7	8	9	10
No. 910—Boker's Round, per dozen	\$1.30	1.30	1.30	1.30	1.30	1.30	1.30	1.55	1.85

OPEN BELT PUNCHES

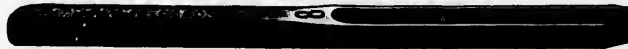

Nos.....	7	8	9	10	11	12
Per dozen.....	\$2.20	2.20	2.50	2.50	3.10	3.10

SPRING BELT PUNCHES

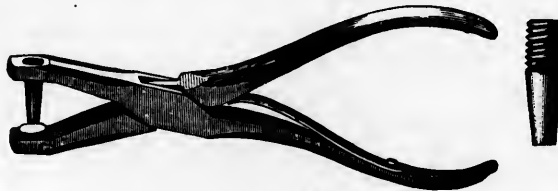

Nos. 10 and 12

No. 10—With Single Tube.....	per doz.	\$4.15
" 12— " 2 Extra ".....	"	7.05
" 3785—Boker's Spring Punches, with Single Tube.....	"	2.85
No. 3785 Punch made from Stamped Sheet Steel.		

REVOLVING SPRING BELT PUNCH



No. 24

No. 24.....	per doz.	\$11.70
Extra Tubes, assorted for Nos. 10 and 12.....	"	1.30
" " " " No. 24.....	"	1.00
Spring Belt Punches, half dozen in a box; others, one dozen.		

THE BUFFALO BELT FASTENER



No. 6—	250 in a box	per 1,000	\$5.00
" 7—	250 "	"	4.00
" 8—	500 "	"	3.50
" 10—	1,000 "	"	2.50
" 13—	1,000 "	"	2.00
" 15—	1,000 "	"	1.50

RAPID HARNESS MENDERS



FULL SIZE OUTS

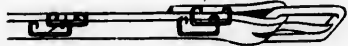

CUT SHOWING MENDER IN USE



Rapid Harness Mender.....per dozen boxes \$2.70
 One gross assorted sizes in a box, 2 dozen boxes in a case.

BELT RIVETS AND BURS



COPPER RIVETS AND BURS

Length.....	$\frac{1}{4}$	$\frac{3}{8}$	$\frac{1}{2}$	$\frac{3}{4}$	$\frac{1}{2}$	$\frac{3}{4}$	$\frac{1}{2}$	$\frac{3}{4}$	$\frac{1}{2}$	$\frac{3}{4}$	$\frac{1}{2}$	$\frac{3}{4}$	$\frac{1}{2}$	$\frac{3}{4}$
Nos.	7	8	10	12	7	8	10	12	7	8	10	12	7	8
Copper Rivets...per lb.	\$0.40	0.50	0.54	0.58	\$0.40	0.50	0.54	0.58	\$0.40	0.50	0.54	0.58	\$0.40	0.50
Copper Burs....	0.40	0.50	0.54	0.58	0.40	0.50	0.54	0.58	0.40	0.50	0.54	0.58	0.40	0.50

In one pound boxes.

Copper Rivets and Burs in half pound boxes, 10 boxes in a carton, assorted, No. 8 x $\frac{1}{4}$, $\frac{3}{8}$, $\frac{1}{2}$ and $\frac{3}{4}$ inch, at an advance of 1 cent per pound, net.

Approximate Number of Copper Belt Rivets and Burs in a pound.

Rivets.....	$\frac{1}{4}$	$\frac{3}{8}$	$\frac{1}{2}$	$\frac{3}{4}$	$\frac{1}{2}$	$\frac{3}{4}$	$\frac{1}{2}$	$\frac{3}{4}$	$\frac{1}{2}$	$\frac{3}{4}$	$\frac{1}{2}$	$\frac{3}{4}$	Burs.
No. 7.....	262	214	181	171	158	152	135	119	102	92	89	79	316
" 8.....	281	200	238	208	192	175	155	120	120	108	93	85	303
" 10.....	472	300	300	320	293	269	248	210	180	163	143	125	105
" 12.....	530	408	415	370	340	302	287	243	222	193	173	155	1045

IRON BELT RIVETS, COPPERED OR TINNED

In one pound boxes.

Length.....	$\frac{1}{4}$	$\frac{3}{8}$	$\frac{1}{2}$	$\frac{3}{4}$	$\frac{1}{2}$	$\frac{3}{4}$	$\frac{1}{2}$	$\frac{3}{4}$	$\frac{1}{2}$	$\frac{3}{4}$	$\frac{1}{2}$	$\frac{3}{4}$	inch.
No. 8.....per pound	\$0.25	0.25	0.24	0.23	0.22	0.22	0.22	0.22	0.22	0.22	0.22	0.22	0.22

ANNEALED IRON BURS, BLACK OR TINNED

In one pound boxes.

Nos.	3	4	5	6	7	8	9	10	12
Black.....per pound	\$0.25	0.26	0.27	0.30	0.32	0.33	0.34	0.35	0.42
Coppered or Tinned....	0.31	0.32	0.33	0.36	0.38	0.39	0.40	0.41	0.48

SLOTTED CLINCH RIVETS

COPPERED



These Rivets can be used for the repair of Harness, Halters, Belts, Bags, Shoes and Straps; with each box a Rivet Set or Holder is included.

No. 9—Assorted, $\frac{1}{4}$ to $\frac{1}{2}$ inch..... per carton \$1.80
 100 Rivets in a box, 12 boxes in a carton.

CAST STEEL RIVET SETS



FULL SIZE CUT OF No. 3

Nos.	00	0	1	2	3	4	5	6	7	8	FULL SIZE OF RIVET SET HOLES
Nos.....	00	0	1	2	3	4	5	6	7	8	
Suitable for Copper Belt Rivets, Nos.....						7	8	9	10	12	
Per dozen.....	\$5.40	5.40	4.55	4.55	3.00	3.00	2.70	2.70	2.30	2.30	

Half-dozen in a box.

STEAM SHEET PACKING



RUBBER PACKING

Made with cloth insertion, cloth on one side or cloth on both sides. One ply of cloth to every $\frac{1}{8}$ inch thickness.

Thickness	$\frac{1}{16}$	$\frac{1}{8}$	$\frac{3}{16}$	$\frac{1}{4}$	$\frac{5}{16}$	$\frac{3}{8}$	$\frac{1}{2}$ inch.
1-Ply	\$0.70	0.65	0.60	0.55	0.55	0.55	0.55
2-Ply	0.70	0.65	0.60	0.58	0.55	0.55	0.55
3-Ply	0.70	0.65	0.60	0.58	0.58	0.55	0.55
4-Ply	0.70	0.65	0.60	0.61	0.61	0.58	0.55

Pure Gum Sheet Packing, without Cloth	per lb.	\$1.40
Wire Insertion Sheet Packing, Plain Rubber, $\frac{1}{8}$ inch and thicker	"	0.80
Plumbago " " Self Vulcanizing, $\frac{1}{8}$ or $\frac{1}{4}$ inch thick	"	0.70
Rainbow " " $\frac{1}{8}$, $\frac{1}{4}$, $\frac{1}{2}$ or $\frac{3}{4}$ inch thick	"	1.00
Asbestos " " $\frac{1}{8}$ to $\frac{1}{2}$ inch thick	"	0.10

Asbestos Sheet Packing is kept in stock 40 x 40 inch, and weighs approximately $\frac{1}{8}$ 2 lbs., $\frac{1}{4}$ 3 lbs., $\frac{1}{2}$ 5 lbs., $\frac{3}{4}$ 8 lbs., 1 11 lbs., $\frac{1}{2}$ inch 16 lbs. per sheet.

GASKETS AND RINGS CUT TO ORDER



Fibrous, $\frac{1}{8}$ inch thick or less	per lb.	\$0.90
" " and upwards	"	0.80
Cloth Insertion, $\frac{1}{8}$ inch thick or less	"	1.25
" " and upwards	"	1.00
Pure Gum, any size and thickness	"	1.50
Plumbago Packing, any size and thickness	"	1.00

ECLIPSE SECTIONAL RAINBOW GASKETS

Diameter, $\frac{1}{2}$, $\frac{3}{4}$, 1, 1 1/2 inch, in boxes 5 to 6 lbs. per lb. \$1.00

The Eclipse Gasket is composed of the celebrated Rainbow Packing Compound, can be readily fitted to any size man or hand hole plate in use. Explicit directions with each box.

PISTON PACKING



TUCK'S ROUND



SQUARE DUCK



RUBBER BACK

Tuck's Round or Square Duck, $\frac{1}{2}$ to 2 inch	per lb.	\$0.85
Rubber Back Packing, $\frac{1}{2}$ to 2 inch	"	1.00
Square Flax " $\frac{1}{2}$ to 1 "	"	0.45
Soapstone " $\frac{1}{2}$ to 1 " diameter	"	0.20
Plumbago " $\frac{1}{2}$ to 1 "	"	0.00
Asbestos " $\frac{1}{2}$ to 1 "	"	0.40
" " Wick in $\frac{1}{2}$ lb. balls	"	0.40
" " " in balls	"	0.28
Cotton " in coils	"	0.15
Jute " " "	"	0.18
Russian Hemp " " "	"	0.30
Italian " " " No. 1, in coils	"	0.25
" " " " 2 " "	"	0.25

In coils about 50 lbs.

each box a

carton \$1.80

FULL SIZE OF
RIVET
SET HOLES

7 8

2.30 2.30

SPIRAL PISTON PACKING



ELASTIC RING



SPIRAL



SECTIONAL RING

GUTTAPERCH BRAND

Spiral Packing, 12 feet in a box, $\frac{1}{8}$ to 1 in. kept in stock (larger size to 2 in. to order).....per lb. \$1.20
 Elastic and Sectional Ring Packing..... " 1.20

GARLOCK PATENT PACKING

Garlock's Spiral Packing, 12 feet in a box.....per lb. 1.20
 Garlock's Elastic and Sectional Ring Packing..... " 1.20

When ordering Elastic or Sectional Ring Packing, give exact diameter of piston, valve, or cut-off rod to be packed, also the diameter and depth of the stuffing box, state number of rings wanted and whether "Elastic" or "Sectional Rings" are preferred.

Approximate Weight of Spiral Packing in a Box of Twelve Feet

Size.....	$\frac{9}{16}$	$\frac{1}{4}$	$\frac{5}{16}$	$\frac{3}{8}$	$\frac{7}{16}$	$\frac{1}{2}$	$\frac{5}{8}$	$\frac{3}{4}$	$\frac{7}{8}$	in.
Weights.....	$\frac{1}{2}$	$\frac{3}{4}$	1	$1\frac{1}{4}$	$1\frac{3}{4}$	2	$3\frac{1}{4}$	$4\frac{3}{4}$	$6\frac{3}{4}$	$8\frac{1}{2}$ lb.

MILLBOARD

English Millboard, 48 x 34, $\frac{1}{4}$ and $\frac{7}{16}$ thick.....per 100 lbs. \$ 8.25
 American " 44 x 34, " " "..... " 11 65

COTTON WASTE



In 100 and 500 lb. bales.

Extra M. C. White Cotton Waste.....	\$ 2.00	per lb. \$0.12
No. 1 " " " ".....	\$ 2.00	" 0.11
Extra " Colored " ".....	\$ 2.00	" 0.08

STEEL WOOL

Consists of finely shredded steel, and is suitable for "rubbing down" varnish or paint on fine woods. It is soft, pliable and easy to handle.

Nos.....	0	1	3	
For.....	Polishing.	Rubbing.	Scouring.	
Per lb.....	\$0.75	0.60	0.60	

OAKUM

In 50 lb. bales.

U.S. Navy Oakum.....	per 100 lbs. \$ 9.50
" " Spun.....	" 11.50
Plumbers' ".....	" 5.50
Spun Caulking Cotton.....	" 15.00

HOSE NOZZLES



MAGIC



PLAIN, No. 1772

Size of Hose Coupling.....	¾	1	1¼	1½	2	2½ inch.
Short Pattern.....Length	7	8	8½	9	11	16 "
Long "....."	8	10	12	14	16	20 "
Diameter of Openings.....	¾	1	1¼	1½	2	2½ "
Short Pattern.....each	\$0.65	0.85	1.65	2.10	3.15	6.25
Long "....."	0.85	1.25	2.50	3.00	5.00	8.35



GEM

COMBINED STREAM OR SPRAY

Magic, Polished, for ½ or ¾ inch Hose Coupling.....	each	\$1.00
" Nickel-plated, " " " ".....	"	1.17
Gem, Polished, " " " ".....	"	1.00
" Nickel-plated, " " " ".....	"	1.25

HOSE COUPLINGS



Size.....	½	¾	1	1¼	1½	2	2½	3 inch
Per dozen.....	\$2.40	2.40	4.40	10.00	14.00	24.00	48.00	76.00

Hose Couplings, 1½ and larger, are fitted with lugs.



SHERMAN HOSE CLAMP

BRASS

Size.....	¾	1½	¾	1 inch.
Per dozen.....	\$0.00	0.00	0.00	2.00

HOSE MENDERS



SHERMAN'S SEAMLESS BRASS

Size.....	½	¾ inch
Per dozen.....	\$1.20	1.20



COOPER'S SEAMLESS BRASS

Size.....	½	¾ inch.
Per dozen.....	\$1.70	1.70

HUDSON'S HOSE MENDERS

One set in a box.

Each box contains 1 pair Pliers, 20 Bands, and 6 Repair Tubes.
 For $\frac{1}{2}$ or $\frac{3}{4}$ Hose per box \$1.00

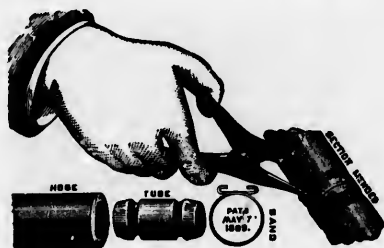

PARTS SEPARATE

Pliers for fastening Bands	per doz.	\$5.00
Size of Hose	$\frac{1}{2}$ $\frac{3}{4}$ 1 inch.	
Bands	per doz.	\$0.25 0.30 0.60
Repair Tubes	"	0.49 0.50 1.00

BIB, HOSE, AND GAUGE GLASS WASHERS

FULLER BIB WASHERS

COMPRESSION BIB WASHERS

HOSE COUPLING WASHERS

GAUGE GLASS WASHERS



No. 1848



No. 1849



No. 1851



No. 1852

Size		%	$\frac{1}{2}$	$\frac{3}{4}$	1 inch.
No. 1848—Fuller Bib Washers	per doz.	\$0.24	0.30	0.30	0.40
" 1849—Boss Compression Bib Washers	per 100	\$1.50	1.60	2.00	2.50
" 1851—Rubber Hose Coupling Washers	per doz.	0.15	0.15	0.15
" 1852— " Gauge Glass "	"	0.50	0.50	0.60	0.75

LAWN

SPRINKLERS

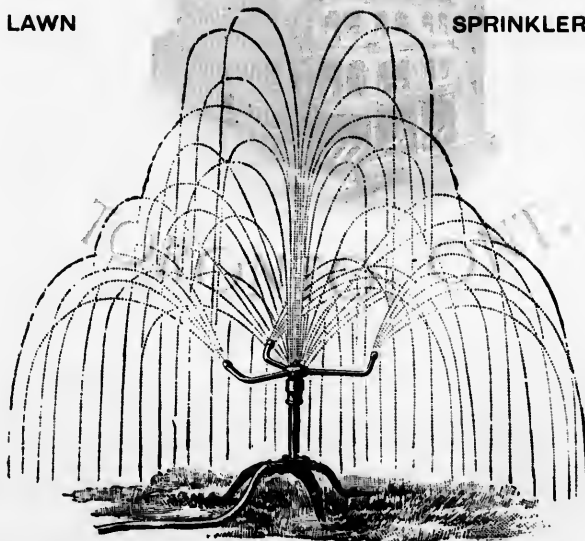

REVOLVING HEAD

Wolverine Sprinkler, top and arms brass, plated, base and legs japanned each \$2.15
 Peerless Sprinkler, arms brass, polished. Standard, base and legs japanned " 1.50



GEM

3 inch
76.00

1 inch.
2.00



SS

$\frac{3}{4}$ inch.
1.70

LAWN SPRINKLERS



CHAMPION



DANDY

Champion Sprinklers with Spike, Plated, for $\frac{1}{2}$ or $\frac{3}{4}$ inch Couplings	per doz.	\$9.20
Dandy " " " " " $\frac{1}{2}$ or $\frac{3}{4}$ " "	"	9.00

GARDEN SYRINGES



No. 413E—Brass, $1\frac{1}{2}$ x 18 inch, with Stream and Spray	per doz.	16.25
" 2015 — Zinc, $1\frac{1}{8}$ x 18 " with Spray only	"	5.25

JOHNSTON'S FORCE PUMP



SHOWING PUMP WHEN ATTACHED TO PAIL

With 3 feet Hose.....each \$8.00

HOSE REELS

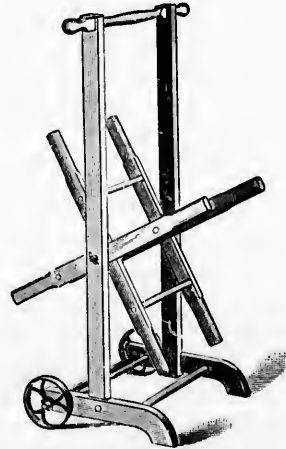

With Drum.....	per doz.	22.00
Without "	"	14.00

HYDRAULIC RAMS

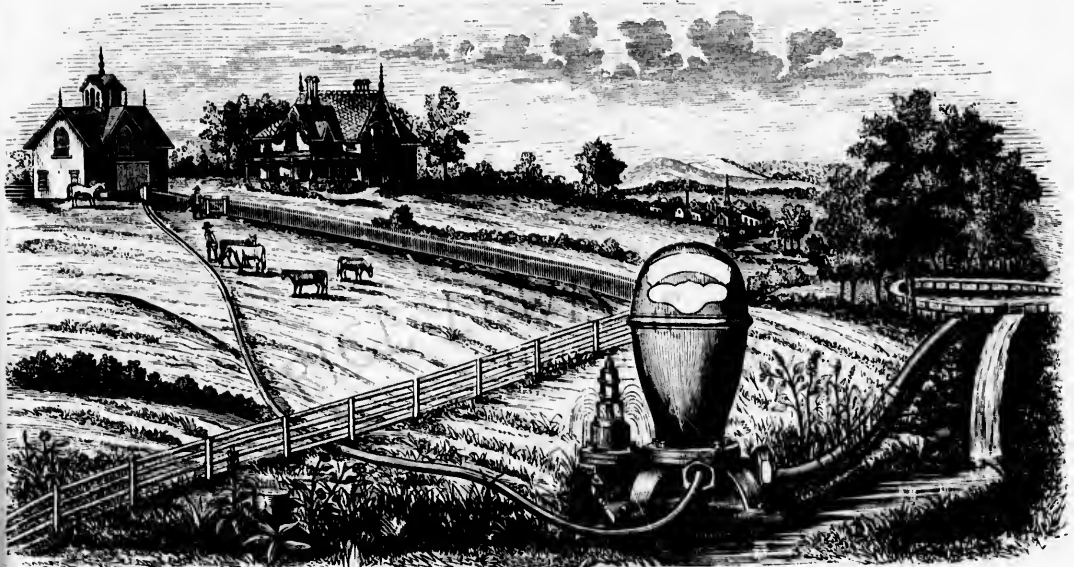

HYDRAULIC RAM IN OPERATION

The various uses of the Ram are at once obvious, viz.: For the purpose of irrigating lands, supplying dwellings, gardens, factories, villages, engines, railroad stations, stock yards, etc., with running water.

The size of the pipes should vary in proportion to the distance the water is to be conveyed, as the greater the distance the larger the pipe in proportion to the size of the machine. This, however, applies to only the discharge pipe.

By means of an Adjuster applied to each of the rams, the quantity of water drawn from the fountain may be varied at pleasure, thus readily adapting the machine to a variable supply. The annexed table exhibits at a glance the capacity, size, price, etc. Pipe furnished when ordered.

GENERAL RULE.—Multiply the quantity supplied by the spring (in gallons per minute) by 65. Multiply this product by the "Head" or number of feet in fall; then divide by 100 times the height to which the water is to be elevated. The result will give the quantity of water raised per minute.

The Rams are fitted for either wrought iron pipe or lead pipe.

Where water is to be forced to any very great distance (say more than 75 rods), it is preferable to use a Discharge Pipe of larger caliber than named in the table below. With a given supply of water under a great fall, the Ram is not required to be of as large size as for the same quantity of water under a less fall. That is, the No. 4 Ram would be of sufficient capacity for taking water from a spring or brook, furnishing seven gallons per minute, where the fall was eight or ten feet; when, if there was not over three or four feet fall to the same spring or brook, then a No. 5 Ram would be better adapted to the place. The Ram can be placed in a pit, and the pipes should be underground, for protection against frost or other injury.

Table giving the Capacity of the Various Sizes of Rams, and the Dimensions of the Pipes to be used in Connection with the same.

SIZE OF RAMS.	Quantity of Water furnished per Minute by the Spring or Brook to which the Ram is adapted.	Length of Drive Pipe.	CALIBER OF PIPES.		Price Each.
			Drive.	Discharge.	
No. 2.....	$\frac{1}{2}$ gals. to 2 gals. per minute.	25 to 50 feet.	$\frac{3}{4}$ inch.	$\frac{1}{2}$ inch.	\$ 9.00.
" 3.....	1 " 4 " "	25 to 50 "	1 "	$\frac{3}{4}$ "	11.00.
" 4.....	2 " 8 " "	25 to 50 "	1 $\frac{1}{4}$ "	1 "	14.00.
" 5.....	3 " 14 " "	25 to 50 "	2 "	1 $\frac{1}{2}$ "	22.00.
" 6.....	4 " 25 " "	30 to 50 "	2 $\frac{1}{2}$ "	2 "	40.00.
" 7.....	8 " 60 " "	30 to 50 "	4 "	2 $\frac{1}{2}$ "	75.00.
" 8.....	12 " 120 " "	30 to 50 "	6 "	3 $\frac{1}{2}$ "	125.00.
" 9.....	80 " 250 " "	30 to 50 "	9 "	4 $\frac{1}{2}$ "	225.00.

For Patent Vibration Joint Air Chamber, add to list No. 2, \$1.00; No. 3, \$1.00; No. 4, \$1.50; and No. 5, \$2.00 extra.

CISTERN PUMPS

REVOLVING CLOSE TOP



No. A, PITCHER SPOUT



No. B, CLOSE SPOUT

These Pumps are to be used for either lead or gas pipe by a coupling or nut fastened to the hub through which a soldering tube is introduced. They are also anti-freezing.

Nos.....	1	2	3	4	5
Size of Cylinder.....	2½	3	3½	4	4½ inch.
Suitable for Pipe.....	1	1 or 1½	1½	1½ or 2	2 "
No. A—Pitcher Spout.....each	\$4.25	4.75	5.25	5.75	6.25
" B—Close "....."	4.25	4.75	5.25	5.75



No. C

CLOSE TOP CISTERN PUMP

	Iron	Brass Lined Cylinder.
No. 1—2½ Cylinder, suitable for 1 or 1½ inch Pipe...	\$4.50	7.00
" 2—3 " " " 1½ inch Pipe.....	5.50	8.00
" 3—3½ " " " 1½ or 1¾ inch Pipe..	6.50	10.00

Has strongly Bolted Base with Coupling Attachments below, either for iron or lead pipe. To prevent freezing the lever should be raised to its extreme height, which opens the lower valve and permits the water to run back into the well.

FORCE PUMPS

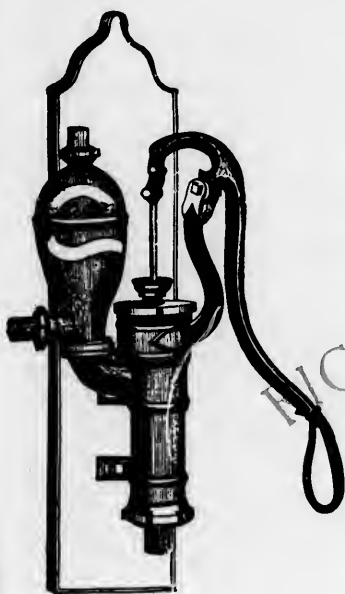

No. 42



No. 41



No. 24

These Pumps are easily adapted to any location. The Lever can be revolved to any desired position and held firmly in place.

FOR EITHER IRON OR LEAD PIPE

	Iron.	Brass Cylinder.
No. 41—2½ inch Cylinder, for 1 or 1½ inch pipe..each	\$11.00	15.00
“ 41—3 “ “ “ 1½ inch pipe..... “	13.00	17.00
“ 42—2½ “ “ “ 1 or 1½ inch pipe.. “	11.00	15.00
“ 42—3 “ “ “ 1½ inch pipe..... “	13.00	17.00

LIFT AND FORCE PUMP

No. 24

WITH WROUGHT IRON EXTENSION PIPE

No. 24—2½ inch Cylinder, for 1½ inch pipe	each	\$12.50
“ 24—3 “ “ “ 1½ “ “		13.50
“ 24—3½ “ “ “ 1½ “ “		14.50
“ 25—Standard without Cylinder		9.00

SPROUT
through which
5
4 4½ inch.
or 2 2 “
75 6.25
75

Brass Lined
Cylinder.

7.00

8.00

10.00

s below, either for
be raised to its ex-
e water to run back

PUMP CYLINDERS

FOR SHALLOW AND DEEP WELLS, OPEN OR DRILLED

No. 58

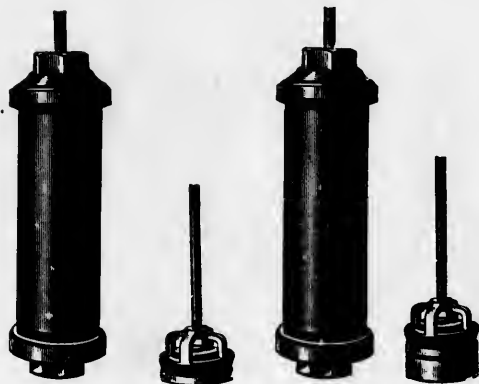

No. 58

No. 59

Size. No.	Size. Inches.	A	B	C	D
		Iron.	Brass Lined.	Brass Body.	Brass Body & Plunger.
1	2½ x 9	\$4.35
2	3 x 9	5.00
3	3½ x 9	5.00
4	2½ x 10	4.35	\$7.75	\$8.00	\$8.75
5	3 x 10	5.00	8.75	9.50	10.50
6	3½ x 10	5.00	9.75	11.50	12.50
7	4 x 10	6.25	10.50	14.00	15.00
8	2½ x 11	5.17	8.50	11.50	12.50
9	3 x 11	6.00	9.50	12.75	14.25
10	3½ x 11	6.83	10.50	15.50	17.50
11	4 x 11	7.62	12.50	21.50	24.00
12	2½ x 13	6.50	9.25	11.75	13.00
13	3 x 13	7.50	10.25	13.50	15.00
14	3½ x 13	8.50	11.25	16.50	19.00
15	4 x 13	10.00	14.00	23.75	27.00
16	4½ x 13	12.50	17.00	28.50	32.00

Nos. 59 and 60

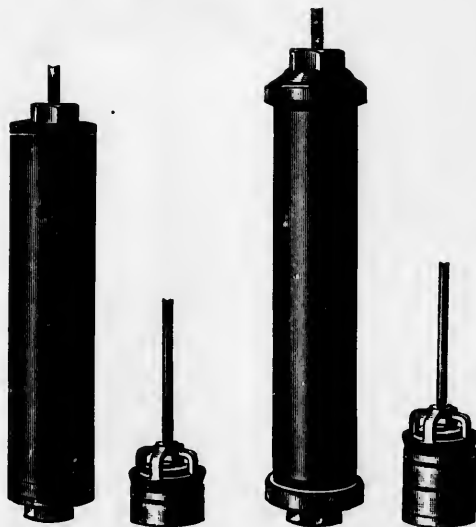

No. 60

No. 61

Size. No.	Size. Inches.	A	B	C	D
		Iron.	Brass Lined	Brass Body.	Brass Body & Plunger.
1	2 x 13	\$10.75	\$12.00
2	2½ x 13	\$6.50	\$9.25	11.75	13.00
3	3 x 13	7.50	10.25	13.50	15.00
4	3½ x 13	8.50	11.25	16.50	19.00
5	4 x 13	10.00	14.00	23.75	27.00
6	4½ x 13	12.50	17.00	28.50	32.00
7	2 x 16	6.00	9.00	10.50	12.00
8	2½ x 16	7.00	10.00	12.50	14.00
9	3 x 16	8.00	11.00	14.00	15.50
10	3½ x 16	9.00	12.00	18.50	21.00
11	4 x 16	10.50	15.75	26.00	29.00
12	4½ x 16	14.00	19.00	30.00	35.00

Nos. 61 and 62

Size. No.	Size. Inches.	A	B	C	D
		Iron.	Brass Lined.	Brass Body.	Brass Body & Plunger.
1	2 x 10	\$ 10.50	\$12.00
2	2½ x 10	\$7.00	\$10.00	12.50	14.00
3	3 x 10	8.00	11.00	14.00	15.50
4	3½ x 10	9.00	12.00	18.50	21.00
5	4 x 10	10.50	15.75	26.00	29.00
6	4½ x 10	13.00	19.00	30.00	35.00
7	2 x 19	13.00	14.50
8	2½ x 19	8.00	10.75	13.75	15.25
9	3 x 19	9.00	11.75	16.50	18.00
10	3½ x 19	10.00	12.75	21.50	24.00
11	4 x 19	11.50	17.50	29.00	32.50
12	4½ x 19	14.00	22.00	33.00	37.50

No. 58—represents Shallow Well Cylinder with Short Plunger and Sand Valve Seats. No. 59—Deep Well Cylinder with Medium Plunger, for Open Wells. No. 60—Deep Well Cylinder with Medium Plunger, for Drilled Wells. No. 61—Deep Well Cylinder with Long Plunger, for Open Wells. No. 62—Similar to No. 60, but with Long Plunger. In ordering, always give Cylinder Number, Size Number and Letter denoting Style of Cylinder wanted.

INJECTORS

THE HOGUE LOCOMOTIVE AND STATIONARY BOILER INJECTOR



This is the latest improved Single Tube Injector in the market. All couplings are made with ground ball joints, every Injector thoroughly tested before leaving the factory, and guaranteed to work perfectly, if properly connected and not over taxed.

SIZE.	Price.	PIPE CONNECTIONS.			Capacity per hour; 1 to 4 ft. lift, 50 to 75 lbs. pressure.		HORSE POWER.
		Steam.	1 Suction.	Delivery.	Maximum.	Minimum.	
	\$16.00				80	55	4 to 8
	18.00				120	70	8 to 10
	20.00				165	90	10 to 15
	25.00				250	135	15 to 25
	30.00				340	165	25 to 35
1	40.00	1	1	1	475	300	35 to 50
1	45.00	1	1	1	575	350	50 to 60
1 1/2	75.00	1 1/2	1 1/2	1 1/2	1300	700	120 to 165
1 1/2	90.00	1 1/2	1 1/2	1 1/2	1740	900	165 to 230
Overflow, 1/4 larger.							

THE PENBERTHY

AUTOMATIC INJECTOR



SIZE.	Price.	Horse Power.	Pipe Connections.	Capacity per hour; 1 to 3 ft. lift, 50 to 75 lbs. pressure.	
				Maximum.	Minimum.
OO.....	\$16.00	4 to 8	1/2 inch	80	55
A.....	18.00	8 to 10	"	120	70
AA.....	20.00	10 to 15	"	165	90
B.....	25.00	15 to 25	"	250	135
BB.....	30.00	25 to 35	"	340	165
C.....	40.00	35 to 50	1 "	475	300
CC.....	45.00	50 to 60	1 "	575	350
D.....	55.00	60 to 95	1 1/2 "	750	400
DD.....	60.00	95 to 120	1 1/2 "	920	500
E.....	75.00	120 to 165	1 1/2 "	1300	700
EE.....	90.00	165 to 230	1 1/2 "	1740	900
F.....	110.00	230 to 290	2 "	2270	1100
FF.....	125.00	290 to 365	2 "	2820	1400

INJECTORS

THE DUPLEX INJECTOR

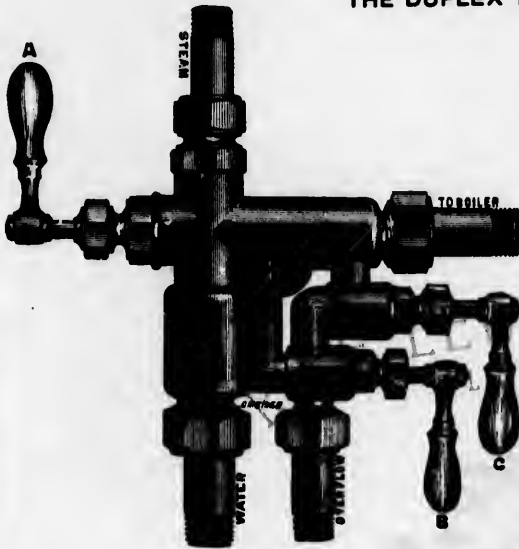

No. of Injector.	SIZE CONNECTIONS.		Gallons per hour @ 90 lbs. Pressure.	Price.
	Water Suction and to Boiler, Inches.	Steam, Inches.		
3	1/2	1/2	65	\$20.00
3 1/2	3/4	3/4	90	21.00
5	1	1	130	25.00
7	1 1/4	1 1/4	210	30.00
9	1 1/2	1 1/2	320	35.00
11	1 3/4	1 3/4	500	50.00
13	2	2	600	60.00
15	2 1/4	2 1/4	1280	75.00
17	2 1/2	2 1/2	1760	90.00
19	2 3/4	2 3/4	2200	110.00
21	3	3	2800	125.00
23	3 1/4	3 1/4	3480	150.00
25	3 1/2	3 1/2	4620	200.00

UNIVERSAL DOUBLE TUBE INJECTOR

KORTING'S

- Working to the best advantage in all cases.
- Takes water at a temperature of 150 degrees Fahr.
- Worked entirely by one handle.
- To start, open with handle.
- To stop, shut with handle.

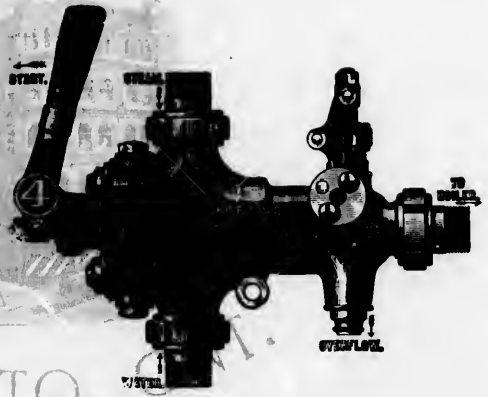

PRICE LIST AND TABLE OF CAPACITIES

Size No.	Price of Injector in Brass.	Size of Iron Pipe Connections, Inches.	PRESSURE OF STEAM IN POUNDS.											
			30		45		60		90		120		150	
			H. P. or Cubic ft. per hour.	Gallons per hour.	H. P. or Cubic ft. per hour.	Gallons per hour.	H. P. or Cubic ft. per hour.	Gallons per hour.	H. P. or Cubic ft. per hour.	Gallons per hour.	H. P. or Cubic ft. per hour.	Gallons per hour.	H. P. or Cubic ft. per hour.	Gallons per hour.
00	\$40.00	1/2	3.5	28	4	30	5	37	6	45	7	52	8	60
0	42.00	3/4	9	67	10.5	79	12	90	13	97	14	105	15	112
1	46.00	1	13	97	14.5	109	16.5	124	18.5	139	21	157	24	180
2	56.00	1 1/4	20	150	22	165	25	187	27	202	29	217	31	232
3	76.00	1 1/2	33	247	36	270	39	292	43	322	48	360	53	307
4	92.00	1 3/4	46	345	51	382	57	427	61	457	66	495	73	547
4 1/2	110.00	2	60	450	68	510	76	570	81	607	86	645	96	720
5	120.00	2 1/4	75	562	86	645	98	735	104	780	111	832	123	922
5 1/2	130.00	2 1/2	90	675	105	787	120	900	128	900	136	1020	150	1125
7	170.00	3	128	900	139	1042	150	1125	172	1260	195	1462	215	1612
8	200.00	3 1/2	165	1237	180	1360	195	1462	225	1687	255	1912	282	2115

These capacities are based on actual tests and are fully guaranteed.

OR

All couplings
before leaving
connected and not

HORSE POWER.	
4 to 8	
8 to 10	
10 to 15	
15 to 25	
25 to 35	
35 to 50	
50 to 60	
120 to 165	
165 to 230	

JECTOR

Capacity per hour: 1 to 3 ft.
t. 50 to 75 lbs. pressure.

Maximum.	Minimum.
80	55
120	70
165	90
250	135
340	165
475	300
575	350
750	400
920	500
1300	700
1740	900
2270	1100
2820	1400

GARDNER STANDARD GOVERNORS

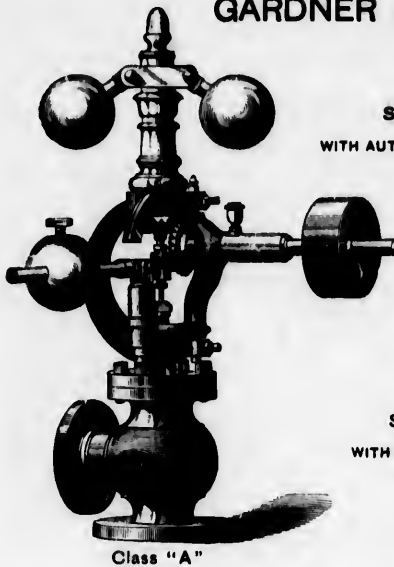

Class "A"
STANDARD GOVERNOR
WITH AUTOMATIC SAFETY STOP AND SPEEDER

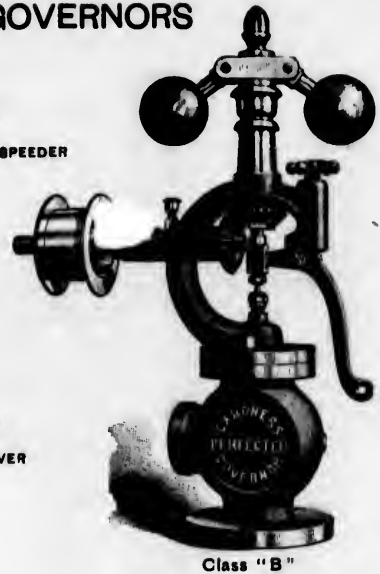

Class "B"
STANDARD GOVERNOR
WITH SPEEDER AND SAWYER'S LEVER

PRICE LIST CLASSES "A" AND "B" STANDARD GOV^S ORS

In ordering, state whether Plain or Finished is desired

SIZE OF GOVERNOR—DIAM. OF OPENING.	¾	1	1¼	1½	2	2¼	2½	3	3½	4	4½	5	6
Class "A," Plain.....				\$20.50	30.00	42.00	48.00	59.00	71.00	83.00	96.00	100.00	140.00
" " "A," Finished.....				\$33.50	40.00	47.00	53.00	67.00	80.00	93.00	107.00	121.00	154.00
" " "B," Plain.....	\$10.00	18.00	21.00	25.00	30.00	35.00	40.00	50.00	60.00	71.00	83.00	94.00	122.00
" " "B," Finished.....	\$18.00	20.00	24.00	29.00	34.00	40.00	45.00	58.00	69.00	81.00	94.00	106.00	136.00

TABLE OF DIMENSIONS OF CLASS "A" STANDARD GOVERNORS

SIZE OF GOVERNOR—DIAMETER OF OPENING.	1½	2	2¼	2½	3	3½	4	4½	5	6
Diameter of Base Flange.....	5½	7	7	8	9	9	10	10	12	14
" " Side.....	Sc'd	Sc'd	7	7	8	9	10	10	11	13
Largest Radius of Balls.....	5	6	6	6½	7½	7½	8½	8½	10	11
From Centre to Side Flange.....	3½	5	5	5½	6	6½	6½	7	7½	8½
From Base to Centre of Inlet.....	4	5	5½	5½	6	6½	6½	7	8	8½
Extreme Height.....	21	25	26	28	32	34	37	38	43	44
From Centre to End of Shaft.....	11	13	13	15	15	17	17	17	21	21
Diameter of Pulley.....	3	5	5	5	5½	5½	6	6	7	7
Width of Belt.....	1½	2	2	2	2	2	2½	2½	3	3
Number of Revolutions.....	250	200	200	200	170	170	160	160	150	150

TABLE OF DIMENSIONS OF CLASS "B" STANDARD GOVERNORS

SIZE OF GOVERNOR—DIAM. OF OPENING.	¾	1	1¼	1½	2	2¼	2½	3	3½	4	4½	5	6
Diameter of Base Flange.....	Sc'd	Sc'd	Sc'd	5½	7	7	8	9	9	10	10	12	14
" " Side.....	Sc'd	Sc'd	Sc'd	Sc'd	Sc'd	7	7	8	9	10	10	11	13
Largest Radius of Balls.....	4	4	5	5	6	6	6½	7½	7½	8½	8½	10	11
From Centre to Side Flange.....	2½	2½	3	3½	5	5	5½	6	6½	6½	7	7½	8½
From Base to Centre of Inlet.....	2½	2½	3	4	5	5½	5½	6	6½	6½	7	8	8½
Extreme Height.....	15	15	20	21	25	26	28	32	34	37	38	43	44
From Centre to End of Shaft.....	9	9	11	11	13	13	15	15	17	17	17	21	21
Diameter of Pulley.....	2	2	3	3	5	5	5	5½	5½	6	6	7	7
Width of Belt.....	1½	1½	1½	1½	2	2	2	2	2	2½	2½	3	3
Number of Revolutions.....	300	300	250	250	200	200	200	170	170	160	160	150	150

GARDNER SPRING GOVERNORS

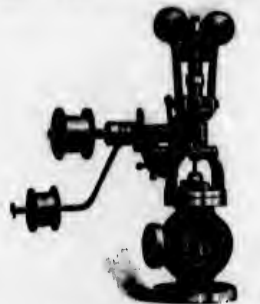
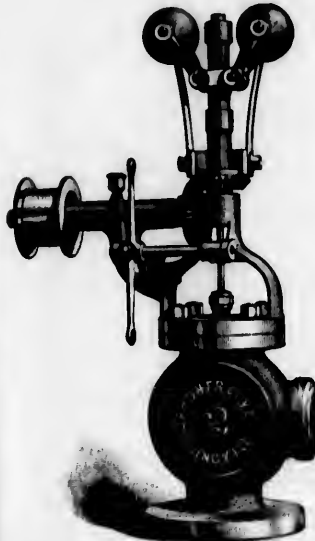

Class "A," SPRING WITH SPEEDER, HAND LEVER AND AUTOMATIC STOP

Class "B," SPRING WITH SPEEDER AND HAND LEVER

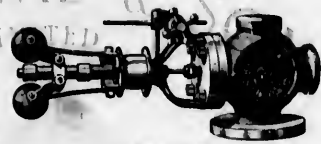

Figure 9

Class "B," SPRING GOVERNOR WITH SPEEDER AND SAWYER'S LEVER, AND WITH OR WITHOUT AUTOMATIC SAFETY STOP

Figure 9 represents our Horizontal Spring Governor, for either vertical or horizontal steam pipe. These are furnished with Straight-Way or Angle-Valve Chambers, and Flanged or Screwed Openings. The position of the Pulley is fixed.

These Spring Governors are designed especially for High-Speed Stationary and Portable Engines. They are quick and sensitive in action. In construction they are fully up to the best modern practice in every particular, and are made in sizes from 1/2 to 7 inches inclusive.

Class "B" represents the Spring Governor without Automatic Stop, but furnished with Speeder and Hand Lever on all sizes.

Class "A" shows the Spring Governor with Automatic Stop. This also has Speeder and Hand Lever.

PRICE LIST OF CLASSES "A" AND "B" SPRING GOVERNORS

DIAM. OF OPENING.	1/2	3/4	1	1 1/4	1 1/2	2	2 1/4	2 1/2	3	3 1/2	4	4 1/2	5	6	7
Class "B," Plain ..	\$14.00	\$16.00	\$18.00	\$21.00	\$25.00	\$30.00	\$35.00	\$40.00	\$50.00	\$60.00	\$71.00	\$83.00	\$94.00	\$122.00	\$150.00
" " "B," Finished ..	16.00	18.00	20.00	24.00	29.00	34.00	40.00	45.00	58.00	69.00	81.00	94.00	100.00	136.00	160.00
" " "A," Plain ..	21.00	24.50	29.50	30.00	42.00	48.00	59.00	71.00	83.00	96.00	100.00	140.00	170.00		
" " "A," Finished ..	23.00	27.50	33.50	40.00	47.00	53.00	67.00	80.00	93.00	107.00	121.00	154.00	186.00		

Class "B" is without Automatic Stop, and Class "A" with Automatic Stop.

TABLE OF DIMENSIONS OF CLASSES "A" AND "B" SPRING GOVERNORS

SIZE OF GOVERNOR.	1/2	3/4	1	1 1/4	1 1/2	2	2 1/4	2 1/2	3	3 1/2	4	4 1/2	5	6	7
Diameter of Base Flange..	Sc'd	Sc'd	Sc'd	Sc'd	5 1/2	7	7	8	9	9	10	10	12	14	15
Diameter of Side Flange..	Sc'd	Sc'd	Sc'd	Sc'd	Sc'd	Sc'd	Sc'd	7	8	9	10	10	11	12	14
Height, inches	12	13	13 1/2	17 1/2	22	23	24	27	29	30	35	36	37	42	44
Radius of Balls	2 1/2	2 1/2	2 1/2	3 1/2	4	4	4	5	5	5	5	5 1/2	6	6
Length of Shaft	8	8	8	11	11	13	13	15	15	15	15	16	18	20	20
Diameter of Pulley	1 1/2	1 1/2	1 1/2	2	2 1/2	2 1/2	2 1/2	3 1/2	3 1/2	3 1/2	4 1/2	4 1/2	4 1/2	6	6
Width of Belt	1	1	1	1 1/2	1 1/2	1 1/2	1 1/2	2	2	2	2 1/2	2 1/2	2 1/2	2 1/2	3
Centre to Side of Chamber	1 1/2	2 1/2	2 1/2	3	3 1/2	5	5	5 1/2	6	6 1/2	6 1/2	7	7 1/2	8 1/2	9
Base to Centre of Chamber	1 1/2	2 1/2	2 1/2	3	4	5	5 1/2	5 1/2	6	6 1/2	6 1/2	7	8	8 1/2	9 1/2
Number of Revolutions ...	600	600	600	450	400	400	400	400	350	350	350	275	275	275	280

Short Rule for Calculating the Size of Pulleys

To FIND DIAMETER OF GOVERNOR SHAFT PULLEY.—Multiply number of revolutions of engine by diameter of engine shaft pulley, and divide product by number of revolutions of governor.

To FIND DIAMETER OF ENGINE SHAFT PULLEY.—Multiply number of revolutions of governor by diameter of governor shaft pulley, and divide product by number of revolutions of engine.

DRINKING FOUNTAINS



COLUMNS



LAMP POSTS

Automatic, fitted with Hyde Valves, no waste of water, at the Base is attached a tray through which waste water runs.

HORSE TROUGHS



These Troughs are strictly Automatic, fitted with Hyde Valves. A large number of them are in use in Toronto and elsewhere, and giving entire satisfaction.

Prices on application.

STREET AND FIRE HYDRANTS

"ST. LAWRENCE"



LAMP POSTS



No. 1

No. 2

No. 3

No. 4

CAST-IRON GAS, WATER & SEWER PIPES.

Thickness and Weight of Standard Cast Iron Pipe

Diameter	inch	3	4	6	8	10	12	14	16	18	20	24	30	36
Thickness	"	$\frac{1}{4}$	$\frac{1}{2}$	$\frac{3}{8}$	$\frac{1}{2}$	$\frac{3}{4}$	$\frac{1}{2}$	$\frac{3}{4}$	$\frac{1}{2}$	$\frac{3}{4}$	$\frac{1}{2}$	$\frac{3}{4}$	$1\frac{1}{4}$	$1\frac{1}{2}$
Weight per Foot	lbs.	17	20	30	45	65	85	110	135	175	200	265	375	480
Weight per Length	"	204	240	360	540	780	1020	1320	1620	2100	2400	3180	4500	5700

Prices on application.

them are in use in

WROUGHT-IRON PIPE

FOR STEAM, WATER OR GAS



Nominal Inside Diameter in Inches.	Nominal Weight per Foot.	Actual Outside Diameter.	Actual Inside Diameter.	Number of Threads to Inch of Screw.	PRICE per Foot.	DISCOUNT % BLACK.	DISCOUNT % GALVANIZED.
1/8	.24	.405	.27	27	.06		
1/4	.42	.54	.36	18	0.08		
3/8	.56	.675	.49	18	0.07		
1/2	.84	.84	.62	14	0.08 1/2		
3/4	1.12	1.05	.82	14	0.12		
1	1.67	1.315	1.04	11 1/2	0.17		
1 1/4	2.24	1.66	1.38	11 1/2	0.24		
1 1/2	2.68	1.90	1.61	11 1/2	0.30		
2	3.60	2.375	2.06	11 1/2	0.43		
2 1/2	5.73	2.875	2.40	8	0.52 1/2		
3	7.54	3.50	3.06	8	0.68 7/8		
3 1/2	9.00	4.00	3.54	8	0.81 6/8		
4	10.66	4.50	4.02	8	0.95 1 1/8		
4 1/2	12.34	5.00	4.50	8	1.25 1 1/4		
5	14.50	5.563	5.04	8	1.42 1 1/2		
6	18.76	6.625	6.06	8	1.85 1 3/4		
7	23.27	7.625	7.02	8	2.45 2 1/2		
8	28.18	8.625	7.98	8	2.95 3 1/8		
9	33.70	9.625	8.93	8	3.75 4 1/8		
10	40.06	10.75	10.01	8	4.75		
11	45.95	12.00	11.25	8	6.00		
12	49.00	12.75	12.00	8	7.00		

WROUGHT-IRON LAP-WELDED BOILER TUBES



Size, Diameter, Outside Measure 1 1/2 1 3/4 2 2 1/4 2 1/2 3 3 1/2 4 inch.

Lengths kept in stock, 10, 12, 14 and 16 feet only.

FITTINGS FOR WROUGHT IRON PIPE

MALLEABLE IRON



BUSHING



PLUG



UNION

Size.....	1/4	3/8	1/2	3/4	1	1 1/4	1 1/2	2	2 1/2	3	inch.
Bushings.....each	\$0.04	0.04	0.05	0.06	0.07	0.09	0.14	0.21	
Plugs....."	\$0.03	0.03	0.05	0.08	0.10	0.16	0.19	0.30	
Unions....."	0.18	0.20	0.22	0.27	0.33	0.40	0.58	0.75	1.55	2.10	

PUMP ROD COUPLINGS

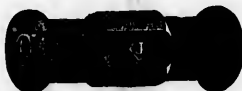

PUMP ROD COUPLINGS

Size.....	3/8	3/8 x 7/16	7/16	1/2	inch.
Threaded.....	10	16 x 14	14	12	"
Malleable Iron, Black.....	\$0.25	0.30	0.25	0.25	per lb.
" " Galvanized.....	0.35	0.40	0.35	0.35	"

CAST FLANGE UNIONS



FLANGE UNION

Size.....	1/2	3/4	1	1 1/4	1 1/2	2	2 1/2	3	3 1/2	4	inch.
Diameter.....	3	3 1/2	3 3/4	4 1/4	4 3/4	5 1/2	5 3/4	6 3/4	7 1/2	8	"
Each.....	\$0.40	0.46	0.52	0.64	0.78	1.00	1.25	1.50	1.80	2.10	

WROUGHT IRON NIPPLES



CLOSE



SHOULDER

Size.....	1/4	3/8	1/2	3/4	1	1 1/4	1 1/2	2	2 1/2	3	3 1/2	4	5	6	inch.	
Close } Right Hand.....	\$0.04	0.04	0.05	0.06	0.09	0.13	0.15	0.20	0.38	0.50	0.73	0.80	1.75	2.00	each.	
Short } " ".....	0.06	0.06	0.07	0.10	0.13	0.19	0.24	0.31	0.55	0.75	1.03	1.23	2.20	2.75	"
Long } " ".....	0.06	0.06	0.07	0.10	0.13	0.19	0.24	0.31	0.55	0.75	1.03	1.23	2.20	2.75	"

Approximate Weight of Malleable Iron Fittings

Size.....	1/4	3/8	1/2	3/4	1	1 1/4	1 1/2	2	2 1/2	3	4	5	6	inch.
Tees.....	2 oz.	3 oz.	4 oz.	8 oz.	13 oz.	1 1/2 lb.	1 1/2 lb.	2 1/2 lb.	5 lb.	8 lb.	13 lb.	30 lb.	35 lb.	each.
Elbows.....	1 1/2 oz.	3 oz.	4 oz.	7 oz.	10 oz.	1 lb.	1 1/4 lb.	2 1/4 lb.	4 1/2 lb.	9 1/2 lb.	12 lb.	20 lb.	28 lb.	"

DISCOUNT
%
GALVANIZED.

3 1/2 4 inch.

MALLEABLE IRON FITTINGS

REVISED CLASSIFICATION AND PRICE LIST

141170



CLASS A

Elbows, $\frac{1}{2}$, $\frac{3}{4}$ x $\frac{1}{2}$, $\frac{1}{2}$ x $\frac{1}{4}$.
 Tees, $\frac{1}{2}$, $\frac{3}{4}$ x $\frac{1}{2}$, $\frac{1}{2}$ x $\frac{1}{4}$, $\frac{1}{2}$ x $\frac{1}{8}$.
 R. and L. Couplings, $\frac{1}{2}$ in.
 Reducing Couplings $\frac{1}{2}$ x $\frac{1}{4}$, $\frac{3}{4}$ x $\frac{1}{4}$.

Couplings R. H., $\frac{1}{2}$.
 Ells, R. and L., $\frac{1}{2}$ and $\frac{3}{4}$.
 R. and L. Return Bends, $\frac{1}{2}$ and $\frac{1}{4}$.
 Plugs, $\frac{1}{2}$.

CLASS B

Elbows, $\frac{1}{2}$, $\frac{3}{4}$ x $\frac{1}{2}$, $\frac{1}{2}$, $\frac{1}{2}$ x $\frac{1}{4}$.
 Tees, $\frac{1}{2}$, $\frac{3}{4}$ x $\frac{3}{4}$, $\frac{1}{2}$ x $\frac{1}{2}$ x $\frac{1}{4}$, $\frac{1}{2}$ x $\frac{1}{4}$ x $\frac{1}{8}$, $\frac{1}{2}$ x $\frac{1}{8}$ x $\frac{1}{8}$.
 Elbows, Side Outlet, $\frac{1}{2}$ inch and smaller.
 Four-way Tees, $\frac{1}{2}$ inch and smaller.
 Street Ells, $\frac{1}{2}$ and $\frac{3}{4}$.
 Crosses, $\frac{1}{2}$, $\frac{3}{4}$ and $\frac{1}{2}$ inch.
 Reducing Crosses, 1 inch and smaller.
 Drop Ells and Tees, $\frac{1}{2}$ inch and smaller.
 Caps, $\frac{1}{2}$ and $\frac{3}{4}$ inch.
 Plugs, $\frac{1}{2}$ and $\frac{3}{4}$ inch.
 Locknuts, $\frac{1}{2}$, $\frac{3}{4}$ and $\frac{1}{2}$.
 Reducing Couplings, $\frac{1}{2}$ x $\frac{1}{4}$ to $\frac{3}{4}$ x $\frac{1}{2}$ inclusive.

Extension Pieces, $\frac{1}{2}$ and $\frac{1}{4}$ inch.
 R. and L. Couplings, $\frac{1}{2}$ and $\frac{3}{4}$.
 R. H. Couplings, $\frac{1}{2}$ and $\frac{3}{4}$ inch.
 R. and L. Elbows, $\frac{1}{2}$ inch.
 R. and L. Return Bends, $\frac{3}{4}$ and 1 inch.
 Waste Nuts, $\frac{1}{2}$ and smaller.
 Chandelier Hooks, all sizes.
 Return Bends, $\frac{1}{2}$ and $\frac{1}{4}$.
 Wall Plates, all sizes.
 45° Ells, $\frac{1}{2}$ inch and smaller.
 Y's, $\frac{1}{2}$ and $\frac{3}{4}$ inch.

CLASS C

Elbows, $\frac{1}{2}$ x $\frac{3}{4}$ and $\frac{1}{2}$.
 Tees, $\frac{1}{2}$ and $\frac{3}{4}$ inch reducing.
 Elbows, Side Outlet, $\frac{3}{4}$ and larger.
 Street Ells, $\frac{1}{2}$, $\frac{3}{4}$ x $\frac{1}{2}$, $\frac{3}{4}$ and 1 x $\frac{3}{4}$ inch.
 Crosses, $\frac{3}{4}$ inch and 1 inch straight.
 Drop Ells, $\frac{3}{4}$ and larger.
 Drop Tees, $\frac{3}{4}$ and larger.
 Four-way Tees, $\frac{3}{4}$ and larger.
 Caps, $\frac{1}{2}$, $\frac{3}{4}$ and 1.
 Plugs, $\frac{1}{2}$, $\frac{3}{4}$ and 1 inch.
 Locknuts, $\frac{3}{4}$, 1 and $1\frac{1}{4}$ inch.

Reducing Couplings, $\frac{3}{4}$ x $\frac{1}{2}$ to 1 inch inclusive.
 R. and L. Couplings, $\frac{1}{2}$ and $\frac{3}{4}$.
 R. H. Couplings, $\frac{1}{2}$ and $\frac{3}{4}$.
 Extension Pieces, $\frac{3}{4}$ and larger.
 Waste Nuts, 1 inch and larger.
 Return Bends, $\frac{3}{4}$ and 1 inch.
 45° Ells, $\frac{3}{4}$ to 2 inch inclusive.
 Y's, 1 inch and larger.
 Return Bends, R. & L., 1 $\frac{1}{4}$ inch and larger.
 Elbows, R. and L., $\frac{3}{4}$ and 1 inch.

CLASS D

Elbows and Tees, $\frac{3}{4}$ and 1 inch.
 Crosses, 1 $\frac{1}{4}$ inch and larger.
 Street Ells, 1 inch and larger.
 Caps, 1 $\frac{1}{4}$ inch and larger.
 Plugs, 1 $\frac{1}{4}$ inch and larger.
 Locknuts, 1 $\frac{1}{4}$ inch and larger.
 Reducing Couplings, 1 $\frac{1}{4}$ inch and larger.
 R. H. Couplings, 1 and 1 $\frac{1}{4}$ inch.

Return Bends, 1 $\frac{1}{4}$ inch and larger.
 R. and L. Couplings, 1 inch and larger.
 45° Elbows, 2 $\frac{1}{4}$ inch and larger.
 Straps, all sizes.
 Elbows, R. and L., 1 $\frac{1}{4}$ inch and larger.
 Such as have smaller outlets than $\frac{3}{4}$ inch to be classed as "C."

CLASS E

Elbows and Tees, 1 $\frac{1}{4}$ inch and larger. Such fittings in this class, that have outlets smaller than 1 inch, to be classed as "D."

Right-Hand Couplings, 1 $\frac{1}{2}$ inch and 2 inch.

The run of Tees gives the size for the purpose of classification, and the outlet being larger does not change it.

PRICE LIST

CLASS.	A	B	C	D	E
Black, per lb.....	\$0.30	\$0.20	\$0.16	\$0.13	\$0.11
Galvanized, per lb.....	0.37	0.27	0.23	0.20	0.18

CAST IRON FITTINGS



ELBOW 45°



ELBOW



TEE



CROSS



RETURN BEND, CLOSE
PATTERN

FOR WROUGHT IRON PIPE

DIAMETER OF PIPE.	1/2	3/4	1	1 1/4	1 1/2	2	2 1/2	3	3 1/2	4	4 1/2	5	6	8
Elbows.....each	\$0.06	\$0.08	\$0.10	\$0.16	\$0.20	\$0.28	\$0.50	\$0.75	\$1.05	\$1.20	\$1.75	\$2.00	\$2.75	\$6.75
“ Right and Left. “	0.07	0.09	0.12	0.18	0.23	0.32	0.60	0.85	1.20	1.40	2.00	2.30	3.15	7.75
“ Reducing..... “	0.07	0.09	0.12	0.18	0.23	0.32	0.60	0.85	1.20	1.40	2.00	2.30	3.15	7.75
“ 45°..... “	0.07	0.10	0.12	0.19	0.24	0.31	0.60	0.90	1.25	1.45	2.20	2.50	3.45	8.50
Tees..... “	0.09	0.12	0.15	0.23	0.29	0.41	0.73	1.10	1.60	1.75	2.55	3.00	4.00	9.75
“ Reducing..... “	0.10	0.14	0.17	0.27	0.33	0.47	0.83	1.25	1.75	2.00	2.95	3.50	4.60	11.25
Bushings..... “	0.04	0.05	0.06	0.07	0.09	0.14	0.21	0.30	0.40	0.50	0.75	0.93	1.25	2.75
Caps..... “	0.23	0.40	0.54	0.75	0.87	1.05	1.20	1.55	2.85
Plugs..... “	0.18	0.25	0.38	0.42	0.65	0.88	1.20	2.75
Return Bends, Close Pattern..... “	0.18	0.20	0.22	0.28	0.40	0.57	1.20	1.70
Return Bends, Close Pattern, R. & L. “	0.21	0.23	0.26	0.33	0.46	0.66	1.40	1.95
Return Bends, Open. “	0.26	0.30	0.40	0.55	0.80	1.35	2.20
“ “ R.&L. “	0.30	0.35	0.46	0.64	0.92	1.55	2.50

Right and Left and Left Hand Fittings not specified above will be charged 15 per cent. more than Right Hand Fittings.

CAST IRON FLANGES



Size of Pipe.....	1/2	3/4	1	1 1/4	1 1/2	2	2 1/2	3	3 1/2	4	5	6	inch.
4 inch diameter.....each	\$0.22	0.22	0.16
5 “ “..... “	0.30	0.30	0.30
6 “ “..... “	0.42	0.40	0.40
8 “ “..... “	0.65	0.95	0.90	0.90	0.90
10 “ “..... “	2.15	2.00	1.90	1.50	1.50	1.50	1.50	1.50

Flanges with other diameters can be supplied on short notice.

HOOK PLATES



Number of Pipes.....	1	2	3	4	5	6	8	10
For 1 inch Pipe, 2 1/2 inch centre to centre..... each	\$0.09	0.18	0.23	0.26	0.32	0.38	0.59	0.70
“ 1 1/2 “ 3 “ “..... “	0.10	0.21	0.27	0.32	0.41	0.52	0.80	1.20
“ 1 1/4 “ 3 1/2 “ “..... “	0.15	0.28	0.43	0.58	0.72	0.88	1.25	1.55
“ 2 “ 4 1/2 “ “..... “	0.22	0.43	0.65	0.90	1.15	1.35

BRANCH TEES

FOR BOX AND CIRCULATION COILS



END FEED



BACK FEED



BACK FEED

BACK OR END FEED

FOR 1 INCH PIPE—1½, 2 AND 2½ INCH RUN

Number of Branches.....	2	3	4	5	6	7	8	9	10	12
1½ inch Run.....each	\$1.00	1.15	1.30	1.45	1.75	2.20	2.45	2.90	3.00	4.75
2 " " " " " "	1.15	1.35	1.60	1.85	2.10	2.45	2.75	3.40	4.00	5.10
2½ " " " " " "	1.75	2.05	2.40	2.75	3.10	3.50	3.75	4.30	5.00	5.85

FOR 1¼ INCH PIPE—2 AND 2½ INCH RUN

Number of Branches.....	2	3	4	5	6	7	8	9	10	12
2 inch Run.....each	\$1.50	1.90	2.40	2.90	3.30	3.90	4.50	5.25	5.85	6.50
2½ " " " " " "	1.95	2.40	2.85	3.55	3.95	4.20	4.95	6.15	6.85	7.65

FOR 1½ INCH PIPE—2½ AND 3 INCH RUN

Number of Branches.....	2	3	4	5	6	7	8	9	10	12
2½ inch Run.....each	\$2.85	3.45	4.15	5.00	5.75	6.50	7.00	8.25	9.25	10.50
3 " " " " " "	3.15	3.80	4.60	5.50	6.25	7.25	7.75	9.00	10.00	11.50

NOTE—In ordering, be particular to state Tapped Right or Left Hand and size of Run. When both ends or one end and back are tapped, add one outlet to give number for the price.

STRAPS



No. 27

WASTE NUTS



No. 28

WALL PLATES



No. 29

Size.....	¼	⅜	½	¾	1	1¼	1½	2 inch.
No. 27— Approximate weight per 100	2½	2½	3½	6	10	18	16½	21½ lbs.
" 28— " " " "	5	7	10	10½	14½ "
" 29— " " " "	..	14 "
Nos. 27, 28 and 29.....	price per pound \$0.20							

GLOBE AND ANGLE VALVES



STANDARD BRASS GLOBE AND ANGLE VALVES

Size.....	¼	⅜	½	¾	1	1¼	1½	2	2½	3 in.
Each.....	\$0.00	0.75	1.00	1.35	1.80	2.80	3.00	5.90	11.75	16.00

JENKINS' PATTERN BRASS GLOBE AND ANGLE VALVES

Size.....	¼	⅜	½	¾	1	1¼	1½	2	2½	3 in.
Each.....	\$1.10	1.25	1.60	2.20	2.80	4.00	5.50	8.00	15.75	22.00

GENUINE JENKINS' BROS. BRASS GLOBE AND ANGLE VALVES

Size.....	¼	⅜	½	¾	1	1¼	1½	2	2½	3 in.
Each.....	\$1.10	1.25	1.60	2.20	2.80	4.00	5.50	8.00	15.75	22.00

JENKINS' DISCS



Size.....	¼	⅜	½	¾	1	1¼	1½	2	2½	3 in.
Each.....	\$0.00	0.08	0.08	0.10	0.12	0.18	0.24	0.30	0.48	0.66

The Disc as shown in cut will fit either imitation or genuine valves. The imitation valve disc has a round hole (not flattened at sides) and will not fit the genuine valve.

IRON BODY GLOBE AND ANGLE VALVES



WITHOUT YOKE



WITH YOKE

BRASS MOUNTED, WITHOUT YOKE

Size.....	1½	2	2½	3 in.	
Screwed Ends.....	each	\$3.50	5.40	7.35	9.80
Flanged Ends.....	"	4.80	7.00	9.00	12.50

BRASS MOUNTED, WITH YOKE

Size.....	2½	3	3½	4	4½	5	6 in.
Screwed Ends.....	\$9.00	12.50	15.25	19.00	24.00	27.00	37.50
Flanged Ends.....	10.75	15.00	18.50	22.50	27.50	31.00	42.00



BACK FEED

9	10	12
0.90	3.00	4.75
1.40	4.00	5.10
1.30	5.00	5.85

10	12
5.85	6.50
6.85	7.65

10	12
9.25	10.50
10.00	11.50

When both ends or one

PLATES



No. 29

1½	2 inch.
10½	21½ lbs.

price per pound \$0.20



STRAIGHT-WAY VALVES

BRASS, WITH STATIONARY SPINDLES

Screwed Top, Double Gate.

Size	1/2	3/4	1	1 1/4	1 1/2	2	2 1/2	3 inch.	
Screwed Ends	each	\$1.30	1.75	2.25	3.25	4.25	6.25	11.50	16.00
Flanged "	"	2.50	3.00	4.00	5.00	7.50	10.00	16.00	20.00
Sliding Stem and Lever	"	2.30	2.95	3.65	4.85	6.05	8.25	13.75	18.50

PEET OR STRAIGHT-WAY VALVES

WITH RISING SPINDLES

Size	1/2	3/4	1	1 1/4	1 1/2	2	2 1/2	3 inch.	
Screwed Ends	each	\$1.30	1.75	2.25	3.25	4.25	6.25	11.50	16.00
Flanged "	"	2.50	3.00	4.00	5.00	7.50	10.00	16.00	20.00
Sliding Stem and Lever	"	2.30	2.95	3.65	4.85	6.05	8.25	13.75	18.50

IRON-BODY STRAIGHT-WAY VALVES

Brass Mounted, Screwed Top.

Diameter of Opening	2	2 1/2	3	3 1/2	4 inch.	
Screwed Ends	each	\$7.00	10.00	12.00	16.00	18.00
Flanged "	"	7.00	10.00	12.00	16.00	18.00
Sliding Stem and Lever	"	9.00	12.25	14.50	18.75	21.00

Brass Mounted, Flanged Top.

Diameter of Opening	3	3 1/2	4	5	6 inch.	
Screwed Ends	each	\$12.00	16.00	18.00	25.00	32.00
Flanged "	"	12.00	16.00	18.00	24.00	31.00
Sliding Stem and Lever	"	14.50	18.75	21.00



IRON-BODY WATER GATES

SCREWED

Flanged Top, Double Gate, to bear Extra Heavy Pressure on either face.

Diameter of Opening	3	4	5	6	7	8	10	12 inch.	
Bell Ends	each	\$15.00	19.00	25.00	30.00	36.00	42.00	60.00	80.00

FLANGED

Valves 14 to 48 inch and Indicator Valves and Posts for Sprinkler Systems. Prices on application.



No. 210, BACK PRESSURE VALVE

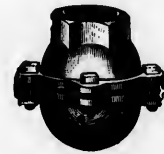

No. 244, FOOT VALVE

Size	2	2 1/2	3	3 1/2	4	5	6 inch.	
No. 240—Back Pressure Valve, Screwed	each	\$11.00	13.00	15.00	10.00	22.50	33.50	43.00
" 241— " " " Flanged	"	12.75	15.00	17.50	22.00	26.00	37.00	47.00
" 244—Foot Valve, Painted, Screwed	"	0.90	1.30	1.85	2.60	2.80	4.25	7.00
" 245— " " Galvanized, Screwed	"	1.45	2.00	2.70	3.00	4.25	6.50	10.00

VALVES

BRASS CHECK VALVES

HORIZONTAL, ANGLE OR VERTICAL



Size.....	1/4	3/8	1/2	3/4	1	1 1/4	1 1/2	2	2 1/2	3 in.
Each.....	\$0.50	0.60	0.85	1.15	1.55	2.30	3.25	5.20	10.00	14.00

JENKINS' PATTERN

Size.....	1/4	3/8	1/2	3/4	1	1 1/4	1 1/2	2	2 1/2	3 in.
Each.....	\$1.10	1.20	1.30	1.00	2.00	3.00	5.00	7.50		

BRASS STRAIGHT-WAY SWINGING CHECK VALVES



PRATT & CADY PATTERN

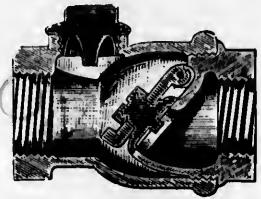
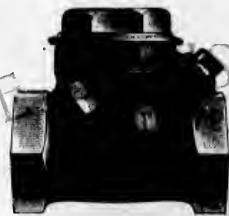

STANDARD PATTERN

Size.....	1/4	3/8	1/2	3/4	1	1 1/4	1 1/2	2	2 1/2	3 in.
Screwed.....	each	\$1.25	1.30	1.75	2.25	3.25	4.25	6.25	11.50	10.00

BRASS STOP COCKS

SQUARE OR FLAT HEAD



Size.....	1/4	3/8	1/2	3/4	1	1 1/4	1 1/2	2	2 1/2	3 in.
Each.....	\$0.70	0.75	1.10	1.50	2.25	3.75	4.80	7.25	14.00	20.00

IRON STOP COCKS

SQUARE OR FLAT HEAD

Size.....	1/2	3/4	1	1 1/4	1 1/2	2	2 1/2	3	4 in.	
All Iron.....	each	\$0.90	1.05	1.30	1.60	1.95	2.70	4.40	6.75	15.50
" with Brass Washers.....	"	1.00	1.20	1.55	1.95	2.35	3.20	5.15	7.75	19.00

BRASS SAFETY VALVES

CROSS OR ANGLE PATTERN

Size.....	1/2	3/4	1	1 1/4	1 1/2	2	2 1/2	3 in.
Screwed End, each	\$2.75	3.50	5.00	7.00	8.50	12.00	22.00	30.00

IRON BODY SAFETY VALVES

BRASS MOUNTED, CROSS OR ANGLE PATTERN

Size.....	2	2 1/2	3	3 1/2	4 in.	
Screwed.....	each	\$7.80	13.25	17.25	23.00	28.75
Flanged.....	"	10.25	16.00	21.50	27.50	34.00

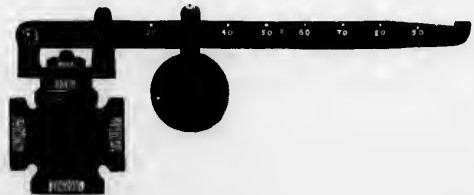

2 1/2	3 inch.
11.50	16.00
16.00	20.00
13.75	18.50

2 1/2	3 inch.
11.50	16.00
16.00	20.00
13.75	18.50



FLANGED

10	12 inch.
60.00	80.00

on application.

VALVE

5	6 inch.
33.50	43.00
37.00	47.00
4.25	7.00
6.50	10.00

GAS FITTERS' GOODS

FOR IRON PIPE

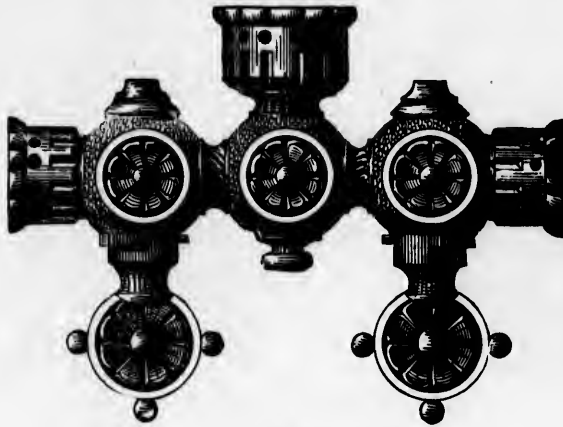

No. 1, 2-LIGHT PENDANT COCK

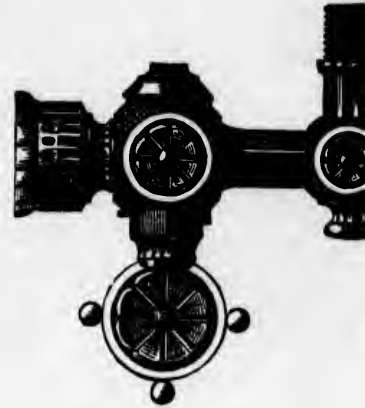

No. 2, L BURNER COCK

Size.....	$\frac{1}{4} \times \frac{1}{8}$	$\frac{3}{8} \times \frac{1}{8}$	$\frac{3}{8} \times \frac{1}{4}$	Size.....	$\frac{1}{8}$	$\frac{1}{4}$
No. 1each	\$0.07	0.81	0.81	No. 2each	\$0.38	0.44

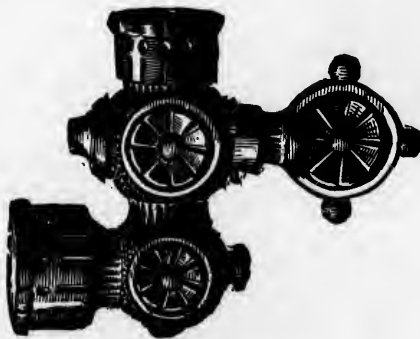

No. 3

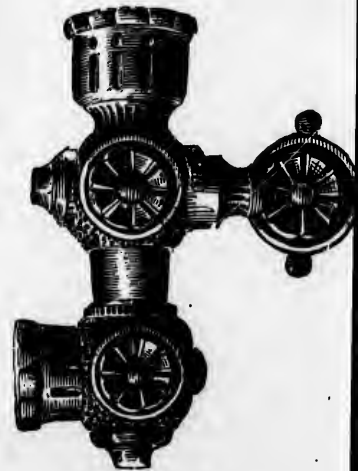

No. 4

Size.....	$\frac{1}{8} \times \frac{1}{8}$	$\frac{1}{4} \times \frac{1}{8}$	$\frac{1}{4} \times \frac{1}{4}$	$\frac{3}{8} \times \frac{1}{8}$	$\frac{3}{8} \times \frac{1}{4}$
No. 3—L Stiff Pendant Cock.....each	\$0.37	0.37	0.44	0.45	0.45
“ 4—Revolving “ “	0.58	0.58	0.67	0.67

GAS FITTERS' GOODS

FOR IRON PIPE



BURNER COCK

.....	1/8	1/4	3/8
each	\$0.38	0.44	0.50



No. 5, PILLAR COCK

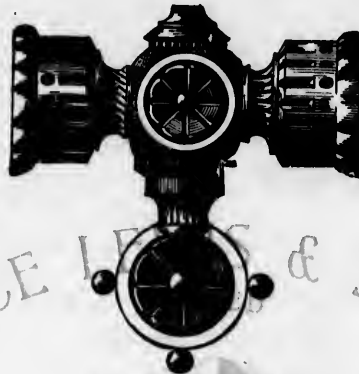

No. 6, STRAIGHT COCK



No. 7, MIDDLE SWING

Size	1/8	1/4	3/8	1/2	3/4 x 1/8	3/8 x 1/4 inch.
No. 5—Pillar Cocks.....each	\$0.27	0.34	0.44	0.54
" 6—Straight Cocks....."	0.30	0.38	0.45	0.37	0.42
" 7—Middle Swings....."	0.31	0.36	0.36
" 8—Universal "....."	0.62	0.66	0.62	0.66



No. 4



No. 9, END NOZZLE



No. 10, SIDE NOZZLE



No. 11, STIFF JOINT

Size	1/8 x 1/8	1/4 x 1/8	3/8 x 1/8	3/8 x 1/4	3/8 x 3/8	1/2 x 1/4	1/2 x 3/8 inch.
No. 9—End Nozzles.....each	\$0.10	0.14	0.14
" 10—Side "....."	0.10	0.14	0.14
" 11—Stiff Joints....."	0.12	0.13	0.14	0.17	0.17



No. 12, BRASS PILLAR WITH LAVA TIPS



No. 13, METAL TIPS



No. 14, LAVA TIPS

x 1/4	3/8 x 1/8	3/8 x 1/4	No. 12—Brass Pillars with Lava Tips.....	per gross	\$3.00
.44	0.45	0.45	" 13—Metal Tips, Excavated Heads.....	"	3.00
.58	0.67	0.67	" 14—Lava " " " 1/2 to 10 feet.....	"	1.25

COMPRESSION HOSE BIBBS



WITHOUT STUFFING BOX

FOR IRON PIPE

Size.....		1/2	5/8	3/4
Finished with Stuffing Box.....	each	\$1.17	1.35	2.10
Finished without Stuffing Box.....	"	1.00	1.17	1.85

‡ Hose Bibbs are screwed for 3/4 inch Iron Pipe.

STOP AND WASTE COCKS

FOR IRON PIPE

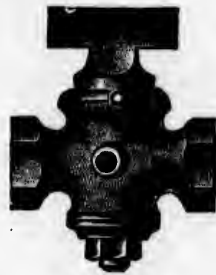

T HANDLE



L HANDLE

Size.....		3/8	1/2	3/4	1 inch.
T Handle.....	each	\$0.95	1.17	1.88	2.75
L Handle.....	"	0.95	1.17	1.88	2.75

CAST IRON ADJUSTABLE STOP COCK BOXES

FOR STREET SERVICES

Prices on application.

COMPRESSION GAUG COCKS



No. 1



No. 4

Size.....		1/2	3/4 inch Pipe.
No. 1—Wood Wheel, without Stuffing Box, Rough.....	each	\$1.00	1.10
" 2— " " with " " ".....	"	1.25	1.35
" 3— " " without " " Finished.....	"	1.00	1.10
" 4— " " with " " ".....	"	1.25	1.35

DUPLEX GAUGE COCKS

RUBBER VALVES



No. 558

Size.....	1/2	3/4	1 inch.
No. 558—Duplex Gauge Cocks.....	each	\$0.00	1.00

BRASS AIR OR PET COCKS



No. 584—T HANDLE

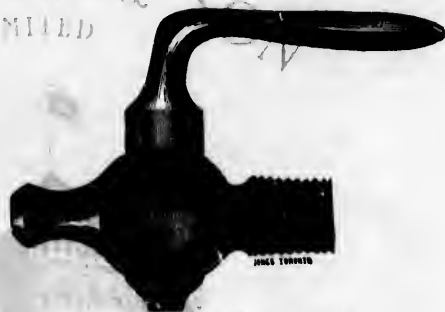

No. 586—LEVER HANDLE

Size.....	1/8	1/4	3/8	1/2	3/4	1 inch.
No. 584—T Handle.....	each	\$0.40	0.45	0.50	0.60	0.75
" 586—Lever Handle.....	0.00	0.05

BRASS STEAM WHISTLES



Diameter of Bell.....	1	1 1/2	2	2 1/2	3	3 1/2	inch.
Size of Iron Pipe.....	1	1 1/2	2	2 1/2	3	3 1/2	"
Without Valve.....	each	\$1.70	2.50	3.25	4.50	6.00	8.50
With Valve.....	"	4.00	4.75	6.50	8.00	11.00
Diameter of Bell.....	4	4 1/2	5	6	8	inch.	
Size of Iron Pipe.....	1	1 1/2	2	2 1/2	3	inch.	
Without Valve.....	each	\$11.00	14.50	18.00	24.00	35.00	
With Valve.....	"	14.00	17.25	22.00	30.00	40.00

WHISTLE VALVES

STEAM METAL

Size.....	1/2	3/4	1	1 1/4	1 1/2	2	2 1/2	3	inch.
Price.....	each	\$2.25	2.75	3.25	4.00	5.50	9.50	20.00	30.00

POP SAFETY VALVES



No. 359



No. 360

Size	1	1 1/4	1 1/2	2	2 1/2	3 inch.
No. 359—Double Seat for Portable Engines	\$12.00	15.00				
" 360—Consolidated, for Stationary Engines	12.00	15.00	20.00	30.00	50.00	65.00
" 361— " with Cover	13.00	16.00	21.00	31.00	51.00	66.00



STEAM GAUGES

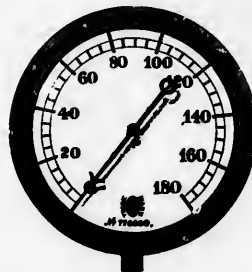

PRESSURE AND VACUUM GAUGES

Pressure Gauges, with Iron or Brass Case and Brass Rings.

Diameter of Dial	2 1/2	4	5	5 1/2	6	8 1/2 inch.
No. 361—Japanned Case, Finished Ring	\$5.00	5.00	7.00	9.00	20.00	
" 362— " " Nickel-Plated	5.50	5.50	7.00	9.00	21.00	
" 363—Finished Brass Case and Ring	\$6.50	7.50	9.00	11.00	14.00	27.00
" 364—Nickel-plated " "	7.50	8.50	10.00	12.50	16.00	30.00
" 365—Japanned Case, Vacuum Gauge			9.00	11.00	14.00	27.00

WATER COLUMNS

- No. 368—Light Pattern, Cast Iron Column, with 5 inch I. C. Steam Gauge, No. 3 Water Gauge, 3 1/2 inch Compression Cocks, Syphon and Cock, complete \$27.00
- No. 369—Heavy Pattern, Cast Iron Column, with 5 inch I. C. Steam Gauge, No. 3 Water Gauge, 3 1/2 inch Compression Cocks, Syphon and Cock, complete 29.00



No. 369

CYLINDER LUBRICATORS

WITH PATENT METALLIC DISC, CAP AND DRAIN VALVE



No. 451



No. 452



No. 453

Diameter of Cup	1	1¼	1½	2	2½	3 inch.
Size of Shank, I. P. Thread	½	¾	1	1½	2	2½
No. 451—With Wood Wheels	each	\$3.25	3.75	4.75	5.75
" 452— " " "	"	2.75	3.50	4.50
" 453— " " "	"	\$2.00	2.20

CASE'S PATENT HAND CYLINDER OIL PUMP

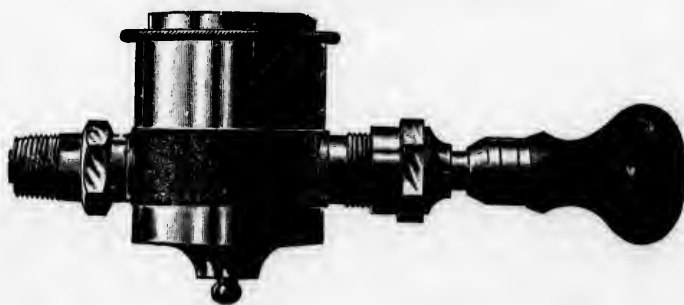

Nos.	1	2	3	4	
Size of Bowl	2¼ x 2¼	2½ x 2½	2¾ x 2¾	3½ x 3½ inch.	
Capacity	¼ Pint	½ Pint	¾ Pint	1 Pint	
Finished	each	\$3.50	4.25	5.00	7.50
Nickel-Plated	"	4.00	5.00	6.00	8.00

GLASS OILERS



No. 499, WITH GUARDS

No. 499						
Size.....	1x1	1¼x1¼	1½x1½	2x2	2½x2½	3x3 inch.
Size of Shank...	¼	½	¾	1	1 or 1½	1 or 1½ "
Each.....	\$1.65	1.90	2.20	3.30	5.50	6.00

No. 501						
Plain Glass Shell, Brass Caps and Plugs.						
Size.....	1¼x1¼	1½x1½	2x2	2½x2½	inch.	
Each.....	\$0.95	1.10	1.70	2.90		

AUTOMATIC SIGHT FEED CYLINDER LUBRICATORS

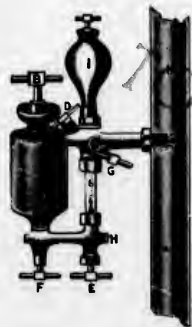

No. 2231

Single Sight Feed.

Suitable for Portable or Stationary Engines.

Capacity.....	¼	½	1 pints.
Brass, Polished.....each	\$5.00	5.50	9.00
" Plated..... "	5.50	6.50	10.00



No. 441

For Stationary or Marine Engines.

Capacity.....	¼	½	1	2 pints.
Brass, Polished.....each	\$17.00	22.00	30.00	45.00
" Plated..... "	20.00	25.00	35.00	50.00

The Pint Cup is made with or without Standard; the 2 Pint with Standard.

OIL AND GREASE CUPS



PLAIN OIL CUPS

Diameter of Cup.....	¾	7/8	1	1¼	1½	1½ inch.
Size of Shank for Iron Pipe.....	½	½	½	½	½	“
Price.....each	\$0.30	0.35	0.40	0.50	0.60	0.90

Diameter of Cup.....	1¾	2	2¼	2½	3	inch.
Size of Shank for Iron Pipe.....	¾	¾	¾	¾	¾	“
Price.....each	\$1.25	1.75	2.25	2.75	4.50	



No. 1

COMPRESSION GREASE CUPS

Outside Diameter.....	1¼	1½	2	2½	inch.
No. 1—Rough.....each	\$0.70	0.80	1.20	1.60	
“ 2—Finished..... “	1.50	2.00	2.50	3.00	



No. 2

NEEDLE SHAFING OILERS



No. 1



No. 3



No. 6



No. 8

No.	Description	Diameter of Bottles inches.	Capacity in ounces.	Price per dozen.
No. 1	Round	2	3	\$3.00
“ 2	“ Flat Side	2	2	3.00
“ 3	“	1½	1½	3.00
“ 3	“	2	1½	3.00
“ 3	“	2½	3	3.00
“ 6	“ Flat Top	3	5½	3.00
“ 8	“ Flat Side	2½	2½	3.00
“ 10	“	2½	2½	3.00
		3½	2	3.00

The above bottles are made of the best White Flint Glass, they are ground perfectly air-tight inside the necks and are fitted with Wood Plugs and Coppered Iron Wires.

OILERS

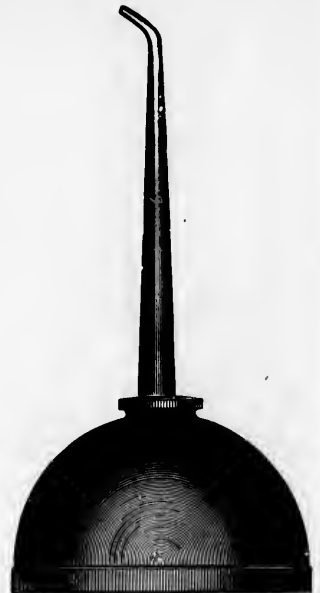

WITH IMPROVED SPRING BOTTOMS

COPPER-PLATED STEEL

Nos.....	12	13	13A	14	14A	14AA	14B	15	15A	16	
Diameter.....	2 $\frac{1}{4}$	3 $\frac{3}{8}$	3 $\frac{3}{8}$	3 $\frac{3}{8}$	3 $\frac{3}{8}$	3 $\frac{3}{8}$	3 $\frac{3}{8}$	4 $\frac{1}{8}$	4 $\frac{1}{8}$	4 $\frac{1}{8}$	inch.
Length of Spout.....	2 $\frac{1}{2}$	3	5	9	3	5	9	3	5	9	"
Per dozen.....	\$4.50	5.50	6.00	6.50	7.50	8.00	8.50	9.25	9.75	10.50	

NICKEL-PLATED

Nos.....					120	130	140AA	160	
Diameter.....					2 $\frac{1}{4}$	3 $\frac{3}{8}$	3 $\frac{3}{8}$	4 $\frac{1}{8}$	inch.
Length of Spout.....					2 $\frac{1}{2}$	3	5	9	"
Per dozen.....					\$6.50	8.00	10.75	14.00	

BRASS

Nos.....	1120	1130	1140	1140A	1140B	1150	1160
Diameter.....	2 $\frac{1}{4}$	3 $\frac{3}{8}$	3 $\frac{3}{8}$	3 $\frac{3}{8}$	3 $\frac{3}{8}$	4 $\frac{1}{8}$	4 $\frac{1}{8}$
Length of Spout.....	2 $\frac{1}{2}$	3	9	3	9	3	9
Per dozen.....	\$6.50	8.00	9.20	10.20	11.20	12.00	14.00

These Oilers are made of very heavy stock and handsomely finished. Spouts 5 inches and under are straight, 9 inches are bent as shown above. 3 $\frac{3}{8}$ inch diameter and under, one dozen; others half-dozen in a box.

HORIZONTAL OILERS

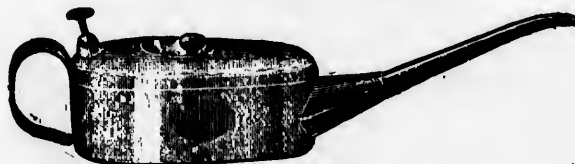

PATENT VALVE SPRING OIL FEEDER

No. 735.....	$\frac{1}{4}$	$\frac{1}{2}$	1	1 $\frac{1}{2}$
Per dozen.....	\$6.75	8.05	10.35	12.30

ROUND BODY, LOCOMOTIVE SPRING VALVE FEEDERS

Extreme Length.....	14	16	18	23
Per dozen.....	\$6.75	8.05	10.35	12.30

SHAFTING, COUPLINGS AND HANGERS



PATENT COLD-ROLLED STEEL SHAFTING

Kept in stock in
16 FEET LENGTHS

Made to Whitworth Standard Gauge and accurately straightened.

Sizes.....	1/4	5/16	3/8	7/16	1/2	9/16	5/8	11/16	3/4	13/16	7/8	15/16	1	1 1/16	1 1/8	inch.
Weight, per foot.....	.167	.200	.275	.371	.507	.684	1.05	1.26	1.50	1.77	2.05	2.35	2.68	3.02	3.38	
Price.....per lb.	\$.....															

Size.....	1 1/16	1 1/4	1 5/8	1 7/8	2	2 1/8	2 1/4	2 1/2	2 3/4	3	inch.
Weight, per foot.....	3.77	4.17	4.81	5.52	6.01	7.06	8.18	9.30	10.00	12.07	
Price.....per lb.	\$.....										

Boxing extra.

Shafting larger than 3 inch to 5 inch in diameter can be furnished to order only.

PATENT COLD-ROLLED SQUARE STEEL

FOR KEYS AND SQUARE SHAFTS

Inches square.....	1/4	5/16	3/8	7/16	1/2	9/16	5/8	11/16	3/4	13/16	7/8	15/16	1
Weight, per foot.....	.213	.270	.352	.470	.652	.850	1.08	1.34	1.61	1.92	2.25	2.60	3.00
Price.....per lb.	\$.....												

RIBBED COMPRESSION COUPLINGS



Size of Shaft.....	1 1/8	1 1/4	1 1/2	1 3/4	2	2 1/4	2 1/2	2 3/4	3	3 1/4	3 1/2	3 3/4	4
Each.....	\$3.05	3.65	4.20	6.90	7.40	9.00	10.00	11.00	13.00				

FLANGE OR FACE COUPLINGS

Bored and Turred, complete with Bolts.

Size of Shaft.....	1 1/4	1 1/2	1 3/4	2	2 1/4	2 1/2	3	inch.
Each.....	\$3.10	3.85	5.85	6.75	7.35	8.25	9.55	

SHAFTING SET COLLARS

Dia. of Hole.....	1	1 1/8	1 1/4	1 1/2	1 3/4	2	inch.
Each.....	\$0.65	0.75	0.85	0.95	1.05	1.25	1.45

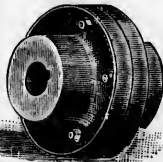

FLANGE COUPLING



SHAFTING COLLAR

ADJUSTABLE SHAFTING HANGERS

SELF-LUBRICATING, DOUBLE LOCKNUT

Size of Shaft....	3/4	1	1 1/4	1 1/2	1 3/4	2	2 1/4	2 1/2	3	inch.
Weight.....lbs.					42	61	82	128	176	265
Each.....	\$1.90	2.25	2.65	3.85	5.05	6.15	8.65	11.15	15.00	

Post Hangers same price as Drop Hangers.

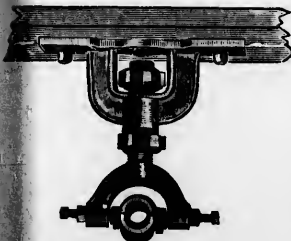

ETS

Per Set.

..... \$7.00
..... 10.00

PATENT OILERS

..... \$8.00
..... 11.00
..... 11.00
..... 11.00

..... 11.00
..... 11.00
..... 11.00

..... 11.00

..... 11.00

..... 11.00

..... 11.00

..... 11.00

..... 11.00

..... 11.00

..... 11.00

..... 11.00

..... 11.00

..... 11.00

..... 11.00

..... 11.00

..... 11.00

..... 11.00

..... 11.00

..... 11.00

..... 11.00

..... 11.00

..... 11.00

..... 11.00

..... 11.00

..... 11.00

..... 11.00

..... 11.00

..... 11.00

..... 11.00

..... 11.00

..... 11.00

..... 11.00

..... 11.00

..... 11.00

..... 11.00

..... 11.00

..... 11.00

..... 11.00

..... 11.00

..... 11.00

..... 11.00

..... 11.00

..... 11.00

..... 11.00

..... 11.00

..... 11.00

..... 11.00

..... 11.00

..... 11.00

..... 11.00

..... 11.00

..... 11.00

..... 11.00

..... 11.00

..... 11.00

..... 11.00

..... 11.00

..... 11.00

..... 11.00

..... 11.00

..... 11.00

..... 11.00

..... 11.00

..... 11.00

..... 11.00

..... 11.00

..... 11.00

..... 11.00

..... 11.00

..... 11.00

..... 11.00

..... 11.00

..... 11.00

..... 11.00

..... 11.00

..... 11.00

..... 11.00

..... 11.00

..... 11.00

..... 11.00

..... 11.00

..... 11.00

..... 11.00

..... 11.00

..... 11.00

..... 11.00

..... 11.00

..... 11.00

..... 11.00

..... 11.00

..... 11.00

..... 11.00

..... 11.00

..... 11.00

..... 11.00

..... 11.00

..... 11.00

..... 11.00

..... 11.00

..... 11.00

..... 11.00

..... 11.00

..... 11.00

..... 11.00

..... 11.00

..... 11.00

..... 11.00

..... 11.00

..... 11.00

..... 11.00

..... 11.00

..... 11.00

..... 11.00

..... 11.00

..... 11.00

..... 11.00

..... 11.00

..... 11.00

..... 11.00

..... 11.00

..... 11.00

..... 11.00

..... 11.00

..... 11.00

..... 11.00

..... 11.00

..... 11.00

..... 11.00

..... 11.00

..... 11.00

..... 11.00

..... 11.00

..... 11.00

..... 11.00

..... 11.00

..... 11.00

..... 11.00

..... 11.00

..... 11.00

..... 11.00

..... 11.00

..... 11.00

..... 11.00

..... 11.00

..... 11.00

..... 11.00

..... 11.00

..... 11.00

..... 11.00

..... 11.00

..... 11.00

..... 11.00

..... 11.00

..... 11.00

..... 11.00

..... 11.00

..... 11.00

..... 11.00

..... 11.00

..... 11.00

..... 11.00

..... 11.00

..... 11.00

..... 11.00

..... 11.00

..... 11.00

..... 11.00

..... 11.00

..... 11.00

..... 11.00

..... 11.00

..... 11.00

..... 11.00

..... 11.00

..... 11.00

..... 11.00

..... 11.00

..... 11.00

..... 11.00

..... 11.00

..... 11.00

..... 11.00

..... 11.00

..... 11.00

..... 11.00

..... 11.00

..... 11.00

..... 11.00

..... 11.00

..... 11.00

..... 11.00

..... 11.00

..... 11.00

..... 11.00

..... 11.00

..... 11.00

..... 11.00

..... 11.00

..... 11.00

..... 11.00

..... 11.00

..... 11.00

..... 11.00

..... 11.00

..... 11.00

..... 11.00

..... 11.00

..... 11.00

.....

METALS



POST'S ZERO Babbitt Metal per lb. \$0.35

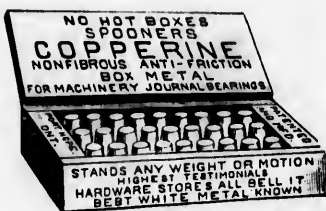

SPOONER'S COPPERINE

	FINEST	No. 1	No. 2
er lb.....	\$0.35	0.21	0.15
No. X—Antifriction Babbitt Metal			per lb. \$0.12
“ 0— “ “ “			“ 0.09

LEAD

	BAR LEAD	PIG LEAD
Per 100 lbs.....	\$....

TIN

	BAR TIN	PIG TIN
Per 100 lbs.....	\$....

COPPER

	BAR	INGOT
Per 100 lbs.....	\$....

CAKE ZINC

ZINC—In Slabs of about 40 lbs..... per 100 lbs. \$....

ANTIMONY

ANTIMONY—In cakes weighing about 30 lbs..... per 100 lbs. \$....

SOLDER

Half and Half Solder, in Bars.....	per 100 lbs.	\$....
Plumbers' “ in Cakes or Bars	“
Wire “ in Coils	“

SPELTER

Best English Brass Brazing Spelter Grain, in 28 lb. Bags.....	per 100 lbs.	\$....
“ “ “ “ “ Square Wire, in Coils	“

DIXON'S PASTE BRAZING GRAPHITE

Thoroughly prevents the Spelter or Brass from sticking to the Metal per lb. \$0.5

LEAD PIPE

LIST OF CALIBRE AND WEIGHT OF LEAD PIPE

CALIBRE.	Weight per yard	CALIBRE.	Weight per yard.	CALIBRE.	Weight per yard.	CALIBRE.	Weight per yard.
1/2 in.	Lbs. 1 1/2	3/4 in. extra light..	Lbs. 5	1 1/4 in. extra light.	Lbs. 6	1 1/2 in. extra strong	Lbs. 20
3/4 in. light.....	2 1/2	light.....	6	light.....	8	2 in. extra light..	16
strong.....	3 and 4*	medium.....	7	medium....	10	light.....	18
1 in. extra light..	2 1/2, 3 and 3 1/2	strong.....	8	strong.....	12	medium.....	20
light.....	4	extra strong	9 and 10*	extra strong	14	strong.....	22
medium....	4 1/2	1 in. extra light.	5	1 1/4 in. extra light.	10	extra strong	24
strong.....	5 and 6*	light.....	6	light.....	11	2 1/2 in. light.....	20
extra strong	7 and 8	medium....	7	medium....	12	medium.....	24
1 1/2 in. extra light..	4 1/2	strong.....	8	strong.....	14	strong.....	27
light.....	5	extra strong	9 and 10	extra strong	16 and 18	extra strong	30 and 32
medium....	6	double extra	12 and 13*	1 1/2 in. light.....	14	light.....	27
strong.....	7	strong.....		medium....	16	medium.....	30
extra strong	8* and 9			strong.....	18	strong.....	34

* Corporation standard.

LEAD PIPE

Lead Pipe, all sizes, put up in coils about 163 lbs. per lb. \$0.07

COMPOSITION GAS TUBING ON REELS

Calibre	3/8	1/2	5/8	3/4	1 inch.
Weight per yard.....	1	1 1/2	2 1/2	3	3 1/2
Average length.....	75	50	40	30	25
Per lb.....	\$0.07 1/2	0.07 1/2	0.07 1/2	0.07 1/2	0.07 1/2

BRASS CASSED TUBING



Lacquered, Iron Lined, 10 or 12 ft. lengths.

Sizes.....	3/8	1/2	5/8	3/4	1	1 1/4	1 1/2	2 inch.
Per 100 feet.....	\$9.00	9.50	11.75	14.25	17.50	21.25	25.50	34.00

SOLID DRAWN BRASS TUBING

Iron Pipe, Sizes.....	1/4	3/8	1/2	5/8	1	1 1/4	1 1/2	2 inch.
Per lb.....								

BRAZED BRASS TUBING

Sizes.....	1/4	3/8	1/2	5/8	3/4	1	1 1/4	1 1/2	2 inch.
Per lb.....									

BRASS CASSED RODS

1/2 inch diameter.....	per 100 ft.	\$2.80
"	"	5.00

SOLID BRASS ROD

Sizes.....	1/4	5/16	3/8	7/16	1/2	5/8	3/4	7/8	1 inch.
Per lb.....	\$0.24	0.24	0.24	0.24	0.24	0.24	0.24	0.24	0.24

SHEET BRASS

Spring, 12 inches Wide

Gauges.....	6	8	10	12	14	15	16	17	18	19	20	21	22	23	24	25	26	27	28
Per lb.....	\$0.23	0.23	0.23	0.23	0.23	0.23	0.23	0.23	0.23	0.23	0.23	0.23	0.23	0.23	0.23	0.24	0.24	0.24	0.24

Soft, 12 inches Wide

Gauges.....	16	18	19	20	21	22	23	24	25	26	27	28	30	32	34
Per lb.....	\$0.22	0.22	0.22	0.22	0.22	0.22	0.22	0.22	0.23	0.23	0.23	0.23	0.23	0.24	0.25

Soft, 16 inches Wide

Gauges.....	16	18	19	20	21	22	23	24	25	26	27	28	30	32	34
Per lb.....	\$0.25	0.25	0.25	0.25	0.26	0.26	0.26	0.26	0.27	0.27	0.27	0.28	0.28	0.29	0.31

Brass in special patterns of wire and strips, price on application.

ALUMINUM AND ALUMINUM ALLOYS

In the form of

INGOTS, CASTINGS, BARS, PLATES, SHEETS, TUBES AND WIRE, AND ALL FORMS OF STRUCTURAL SHAPES

Correspondence Solicited.

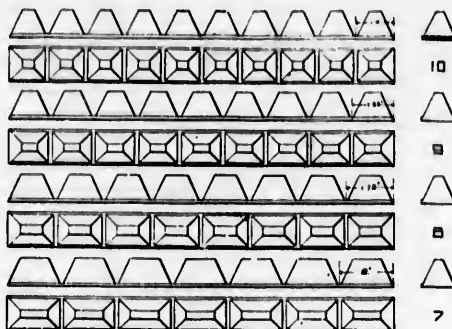

STANDARD RE-MELTING INGOTS

We carry in stock

	INGOT ALUMINUM		SPECIAL CASTING ALLOY	NICKEL ALUMINUM CASTING ALLOY
	No. 1	No. 2	80% pure, alloyed with zinc, copper, tin, manganese and iron. Specific gravity, 3.0.	7 to 10% nickel and copper. Specific gravity about 2.85.
	98% pure.	91% pure.		
Price, less than 50 lbs. \$.....
" 50 to 100 lbs.....
" over 100 lbs.....

SHEET ALUMINUM

12 inches wide, 6 to 8 feet long, kept in stock; other sizes to order.

Gauge Nos.	10 to 19	20 to 24	25 to 30
Price	per lb.

The comparative weight of Aluminum to Brass is as 1 is to 3.19, so that an equivalent price per square foot of Aluminum as compared to Brass for a given amount of money would enable a consumer to purchase the same number of square feet in Aluminum as could be obtained in Brass; but when large quantities of Aluminum are ordered, a reduction in price is made, making the cost of Aluminum considerably cheaper than Brass.

ALUMINUM

This metal has been rolled into sheets of .0007 inch thick. It can also be drawn into tubes or wire, and spun or stamped into different shapes. For stamping or spinning, it must be annealed after rolling. The rigidity and temper of Aluminum is considerably increased by the addition of a few per cent. of hardening ingredients. The metals commonly used for this purpose are nickel, copper, manganese, tin, iron and zinc. In plates or sheets these metals are added in amounts not to exceed 5 or 6 per cent. Greater percentages render these Aluminum alloys non-malleable.

NICKEL ALUMINUM in sheets and sections, having a composition of from two to five per cent. of nickel and copper, alloyed with pure Aluminum, and with a specific gravity of about 2.75, are furnished, either hot rolled and annealed, for stamping and spinning, or medium hard rolled, or cold rolled and very stiff, as may be required. **Nickel Aluminum and Special Casting Alloys** have a tensile strength about equal to that of brass, has about the same shrinkage as brass, and can be as easily toolled.

ALUMINUM, IN INGOTS FOR CASTING, melts at a temperature of about 650 degrees centigrade, or 1,200 Fahrenheit. It is not good practice in making castings to heat it much above its melting point or allow it to remain melted for any great length of time, on account of its capacity for absorbing gases. Aluminum is melted in ordinary plumbago crucibles. No flux is needed to cover the metal, for it is non-volatile at any temperature that can be attained with an ordinary coke fire without blast. A very thin film of oxide forms on the surface of the molten metal, which, while not enough to injure either ingots or castings, protects the metal from further oxidations. The metal should be poured as cold as possible, in order to insure sound castings, free from blow holes (caused by the very great absorption of gas by over-heated molten Aluminum) or cracks and depressions due to shrinkage. The gates should be large, and put in such places on the castings that the metal will not "draw away" where the gate joins the piece.

Aluminum in proportions of two per cent. and over materially decreases the shrinkage of cast-iron. From one to two pounds of Aluminum per ton in cast-iron put into the metal as it is being poured from the spout lessens the tendency of the metal to chill, and permits of sounder castings being made, having a closer grain and hence much easier toolled.

ALUMINUM FOR STRUCTURAL PURPOSES. The attention of those contemplating the use of Aluminum for structural purposes is called to the fact that the elastic limit is closer to the ultimate tensile strength than in any other of the commercial metals, and for this reason the safety factor of four to five means a great deal more than it does in steel or iron where the same safety factor is used. Generally speaking, for purposes where Aluminum alloys are brought into tension, such as in sheets or in rolled shapes, an ultimate tensile strength of from 32,000 to 40,000 pounds per square inch may be reckoned upon (pure metal may be taken at from 24,000 to 28,000 pounds). For the alloy of cast Aluminum on tension the ultimate tensile strength may be taken at from 15,000 to 28,000 pounds per square inch.

GALVANIZED SHEET-IRON



STOCK SIZES

6 ft. x 2½ ft.	28 W.G.	26 W.G.	24 W.G.	22 W.G.	20 W.G.	18 W.G.	17 W.G.
6 " x 3 "	"	"	"	"	"	"	"
8 " x 2½ "	"	"	"	"	"	"	"
8 " x 3 "	"	"	"	"	"	"	"

GALVANIZED CORRUGATED SHEET-IRON

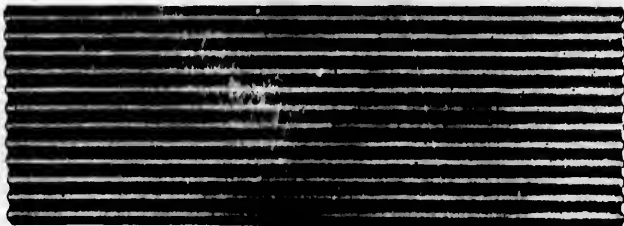

Corrugations 2½ inches from centre to centre. Sheets usually stocked measure 28 inches wide, will cover 28 inches from centre to centre of outside corrugation; length 8 feet. It is suitable for Roofing, Siding, Partitions, Curved Ceilings and Awnings.

Price (square equals 10 x 10 feet) per square \$....

PLANISHED SHEET-IRON

(IMITATION RUSSIAN)

A quality, Rustless, size 00 x 28 inch	per 100 lbs.	\$....
B " " " "	"

SHEET ZINC

No. 8 (No. 27 B.W.G.)	per 100 lbs.	\$....
" 9 " 26 "	"

Size of Sheets, 84 x 36 inch; about 500 lbs. in cask.

PERFORATED SHEET ZINC

Size of Sheets, 3 x 8 feet.

Diameter of Hole	⅜	⅜	⅜	⅜ to ½ inch.
Price per square foot	\$0.22	0.18	0.12	0.10

SIEVES AND RIDDLES

MOULDERS' RIDDLES

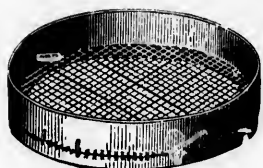

SINGLE RIM RIDDLES

In $\frac{3}{8}$, $\frac{1}{2}$, $\frac{5}{8}$, $\frac{3}{4}$ and 1 inch mesh.

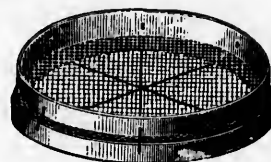

DOUBLE RIM RIDDLES

In Nos. 3, 4, 5, 6, 7, 8, 10, 12, 14 and 16 mesh.

No. 1—Steel or Iron Wire, 18 inch in diameter.....	per doz.	\$ 9.00
" 2—Galvanized Wire " "	"	12.00
" 3—Brass Wire " "	"	15.00

MINERS' EXTRA HEAVY STEEL WIRE RIDDLES

Space.....	$\frac{3}{8}$	$\frac{1}{2}$	$\frac{5}{8}$	$\frac{3}{4}$	1	1 $\frac{1}{8}$	1 $\frac{1}{4}$	1 $\frac{3}{8}$	1 $\frac{1}{2}$ inch.
No. of Wire.....	14	13	12	11	11	10	10	9	9
Per dozen.....	\$10.20	10.20	14.85	13.50	13.50	13.50	13.50	12.50	13.50

These Riddles are 20 inches in diameter, with the steel wire bottom independent of the rim.

SEED AND FLOUR SIEVES

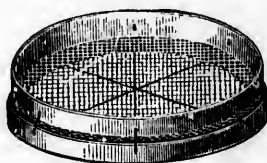

SEED SIEVES

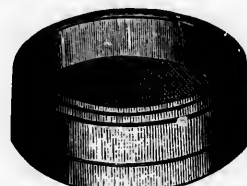

TIMOTHY AND FLOUR SIEVES

No. 4—Seed Sieves, 18 inch in diameter, 2 to 22 mesh.....	per doz.	\$7.20
" 5—Timothy and Flour Sieves, 3 in a nest, 11, 12 and 13 inch diameter, Tinned, 14 to 22 mesh.....	"	2.10
" 7—Potato Riddles, $\frac{1}{2}$ to 2 inch space, 18 inch diameter.....	"	9.00

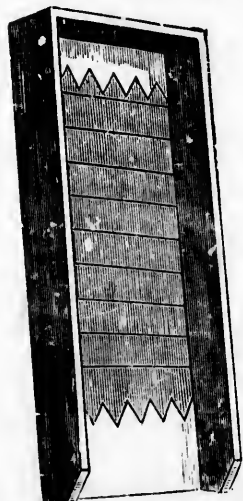

MASON'S SAND SCREEN

SAND AND COAL SCREENS

EXTRA HEAVY SAND SCREENS

No. 3—Crimped, size 7 ft. x 34 inch.....	each	\$7.20
" 4— " " 5 ft. x 23 inch.....	"	6.00

The usual size is $\frac{1}{2}$ mesh in the clear.

EXTRA HEAVY STEEL WIRE COAL SCREENS

$\frac{3}{4}$ to 1 inch square openings.

No. 5—Crimped, size 7 ft. x 34 inch.....	each	\$10.80
" 6 " " 5 ft. x 27 inch.....	"	8.75

WIRE CLOTH

Meshes are from centre to centre of wires. Put up in 12 yard rolls.

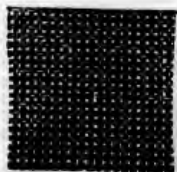

No. 18 MESH, No. 25 WIRE

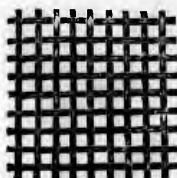

No. 8 MESH, No. 18 WIRE

No.	Size.	No. of Wire.	Cents Per Yard.			
			18 In.	21 In.	24 In.	30 In.
18	2 x 2 Mesh	18	\$0.28	\$0.30	\$0.35	\$0.45
19	2½ x 2½ "	19	0.26	0.30	0.35	0.45
20	3 x 3 "	20	0.28	0.30	0.35	0.45
22	4 x 4 "	22	0.28	0.30	0.35	0.45
23	5 x 5 "	23	0.28	0.30	0.35	0.45
24	6 x 6 "	24	0.28	0.30	0.35	0.45
25	7 x 7 "	25	0.30	0.32	0.37	0.47
26	8 x 8 "	26	0.30	0.32	0.37	0.47
27	9 x 9 "	27	0.30	0.32	0.37	0.47
28	10 x 10 "	28	0.33	0.35	0.40	0.50
30	12 x 12 "	30	0.33	0.35	0.40	0.50
32	14 x 14 "	32	0.35	0.37½	0.43	0.55
34	16 x 16 "	34	0.35	0.37½	0.43	0.55
35	18 x 18 "	35	0.37	0.40	0.45	0.55
36	20 x 20 "	36	0.37	0.40	0.45	0.55
36	22 x 22 "	36	0.37	0.40	0.45	0.55
36	24 x 24 "	36	0.54	0.65
37	26 x 26 "	37	0.60	0.75

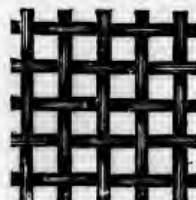

No. 4 MESH, No. 13 WIRE

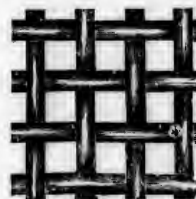

No. 3 MESH, No. 11 WIRE

BRASS AND COPPER WIRE CLOTH

100 FEET ROLLS

Mesh.....	12 x 12	14 x 14	16 x 16	18 x 18	20 x 20	24 x 24	30 x 30	40 x 40	50 x 50	60 x 60
Gauge of Wire...Nos.	24	25	26	27	28	30	31	33	35	36
Per square foot.....	\$0.33	0.33	0.33	0.33	0.33	0.35	0.40	0.45	0.50	0.60

Meshes are from centre to centre of wires.

Brass Milk Strainer Cloth, 50 x 50 Mesh, in 5 feet rolls, 12 inches wide.....per square foot \$0.27

WINDOW SCREENS

HARDWOOD, OIL FINISHED



PERFECTION



NEW EXTENSION

Size.	Per Doz.	Size.	Per Doz.
No. 2—18 inch high, adjusts 20 to 23 inches.....	\$4.15	No. A—18 inch high, adjusts 10 to 24 inches.....	\$4.75
" 3—18 " " " 24 to 40 ".....	4.65	" B—18 " " " 24 to 32 ".....	5.25
" 4—24 " " " 24 to 40 ".....	5.65	" C—22 " " " 32 to 40 ".....	6.25

One dozen in a crate.

SCREEN DOORS

WITH FLUSH MOULDING



No. 13 WIRE



No. 11 WIRE

50 x 50 60 x 60
35 36
0.50 0.60

per square foot \$0.27



No. 100

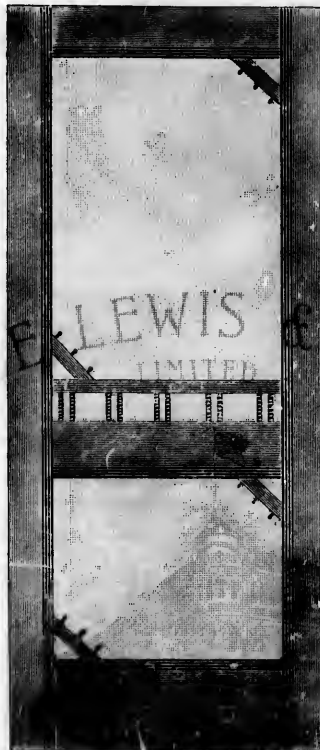

No. 102



No. 104

Wire Cloth, put on with a groove and wedge. Doors are made up from clear, white pine, $\frac{7}{8}$ inch thick; Nos. 100 and 102 are filled and varnished; No. 104, finished in Walnut Stain. Both sides alike.

Size	2 ft. 8 in. x 6 ft. 8 in.	2 ft. 10 in. x 6 ft. 10 in.	3 ft. x 7 ft.
No. 100	per doz. \$22.00	22.00	22.00
" 102	25.75	25.75	25.75
" 104	14.00	14.00	14.00

SCREEN WIRE CLOTH PAINTED GREEN

Double Selvage, Standard Mesh, in 50 Lineal Feet Rolls.

Green Painted Screen Wire Cloth, 12 x 12 Mesh, No. 33 Steel Wire.....per 100 square feet \$2.70
Widths carried in stock: 18, 20, 22, 24, 26, 28, 30, 32, 34 and 36 inches.

Table showing Number of Square Feet from One to Five, 50 Feet Rolls

LINEAL FEET.	Widths													
	18	20	22	24	26	28	30	32	34	36	38	40	42 Inch wide.	
50	75	83 $\frac{1}{2}$	91 $\frac{1}{2}$	100	108 $\frac{1}{2}$	116 $\frac{1}{2}$	125	133 $\frac{1}{2}$	141 $\frac{1}{2}$	150	158 $\frac{1}{2}$	166 $\frac{1}{2}$	175	Sq. ft.
100	150	166 $\frac{1}{2}$	183 $\frac{1}{2}$	200	216 $\frac{1}{2}$	233 $\frac{1}{2}$	250	266 $\frac{1}{2}$	283 $\frac{1}{2}$	300	316 $\frac{1}{2}$	333 $\frac{1}{2}$	350	"
150	225	250	275	300	325	350	375	400	425	450	475	500	525	"
200	300	333 $\frac{1}{2}$	366 $\frac{1}{2}$	400	433 $\frac{1}{2}$	466 $\frac{1}{2}$	500	533 $\frac{1}{2}$	566 $\frac{1}{2}$	600	633 $\frac{1}{2}$	666 $\frac{1}{2}$	700	"
250	375	416 $\frac{1}{2}$	458 $\frac{1}{2}$	500	541 $\frac{1}{2}$	583 $\frac{1}{2}$	625	666 $\frac{1}{2}$	708 $\frac{1}{2}$	750	791 $\frac{1}{2}$	833 $\frac{1}{2}$	875	"

Per Doz.
5000 \$4.75
" 5.25
" 6.25

IRON AND STEEL WIRE



PRICE LIST ADOPTED DEC. 21ST, 1897.

Nos.	6/9	10	11	12	13	14	15	16	17	18	19	20		
Bright	} 2.60	2.70	2.80	3.00	3.20	3.40	3.60	3.80	3.90	4.10	4.30	4.60		
Annealed														
Coppered	3.20	3.30	3.40	3.50	3.75	4.00	4.25		
Galvanized	3.20	3.30	3.40	3.50	3.75	4.00	4.25	5.30	5.50	5.70	6.00		
Tinned	5.75	6.00	6.00	6.50	6.50	6.50	6.60	6.75	6.90	7.00	7.20	7.40		
Nos.	21	22	23	24	25	26	27	28	29	30	31	32	33	34
Bright, Weaving and Binding (Black)	} 5.10	5.25	5.60	6.30	7.00	8.00	8.50	9.00	9.50	10.00	10.50	11.00	12.00	13.00
Tinned														
	7.60	7.80	8.00	8.50	9.00

EXTRAS—NET

Oiled Wire	per 100 lbs.	\$0.05	Bagging and Papering	per 100 lbs.	\$0.10
Spring Wire	"	0.75	50 and 100 lb. Bundles	"	0.05
Special Hay Baling Wire	"	0.25	in 25 lb. Bundles	"	0.10
Best Steel Wire	"	0.65	" 1 lb. Hanks	"	0.50
Bright Soft Drawn	"	0.15	" 1/2 lb. "	"	0.75
Charcoal (Extra Quality)	"	1.00	" 1 lb. "	"	1.00
Packed in Casks or Cases	"	0.15	" 1 oz. Rings	"	4.00

LIGHT STRAIGHTENED WIRE

Cut to Special Exact Length.

Size of Wire	Gauge No.	0 to 5	6 to 9	10 to 11	12 to 16
Over 20 inch long	per 100 lbs.	\$0.25	0.50	0.75	1.00
10 to 20 " "	"	0.50	0.75	1.00	1.50
5 to 10 " "	"	1.00	1.50	2.00	3.00

HEAVY STRAIGHTENED WIRE

In Bundles, cut 10 to 12 ft. long (not exact).

Size	7/16	3/8	1/2	5/16	1/4	3/16	inch.
------------	------	-----	-----	------	-----	------	-------

Prices will be quoted on application.

GALVANIZED TELEGRAPH AND TELEPHONE

Wire Gauge, Nos. 6 to 16.

"B.B."	\$0.15 per 100 lbs. over Plain Galvanized Wire.
Ex. "B.B." Charcoal	1.15 " " " " " "

RYLAND'S COPPERED STEEL SPRING WIRE

Nos.	1 to 8	9	10	11	12	13	14	15	16	17	18
Per 100 lbs.	\$5.85	6.10	6.25	6.55	6.85	7.15	7.45	8.50	8.80	9.10	9.40

This superior quality of Coppered Steel Spring Wire has been stocked for a number of years, and given universal satisfaction.

WIRE

BEST SOFT COPPER WIRE

Nos.	3 to 10	11 to 16	17 and 18	19 and 20	21	22	23	24	25	26
Per lb.	\$0.22	0.23	0.25½	0.26½	0.27½	0.28	0.29	0.30	0.32	0.36

SOFT BRASS WIRE

Nos.	1 to 10	11 to 16	17 and 18	19 and 20	21	22	23	24	25
Per lb.	\$0.18½	0.19	0.19½	0.20	0.21	0.22	0.23	0.24	0.26

BRASS SPRING WIRE per lb. extra, net \$0.02

HAIR WIRE ON SPOOLS



FULL SIZE OF SPOOL

BLACK

TINNED

Gauge of Wire.....	Nos. 32	Nos. 36	Gauge of Wire	Nos. 32	Nos. 36
Black.....	per gross \$4.00	5.25	Tinned.....	per gross \$4.75	6.00

STUBS CAST STEEL

In 3 ft. lengths.

Diameter	¾ ₁₆	¾ ₈	¾	¾ ₂	¾ ₄	¾ ₂	¾	¾ ₂	¾ ₁₆	¾ ₈	¾	¾ ₂	¾	¾ inch.
Per lb.....	\$0.75	0.75	0.75	0.75	0.75	0.75	0.75	0.75	0.75	0.75	0.75	0.75	0.75	0.75

In 12 inch lengths.

Diameter	¾ ₁₆	¾ ₈	¾ ₄	¾ ₂	¾	¾ ₂	¾ ₄	¾ ₈	¾ ₁₆	¾	¾ inch
Per lb.	\$0.82	0.82	0.75	0.75	0.75	0.75	0.75	0.75	0.75	0.75	0.75

Twist Drill and Wire Gauge Nos.	1	2	3	4	5	6	7	8	9	10	11	12	13
Per lb.....	\$0.75	0.75	0.75	0.75	0.75	0.75	0.75	0.75	0.75	0.75	0.75	0.75	0.75

Twist Drill and Wire Gauge Nos.	14	15	16	17	18	19	20	21	22	23	24	25	26
Per lb.....	\$0.75	0.75	0.82	0.82	0.82	0.82	0.82	0.82	0.82	0.82	0.82	0.82	0.82

Twist Drill and Wire Gauge Nos.	27	28	29	30	31	32	33	34	35	36	37	38	39
Per lb.....	\$0.82	0.82	0.82	0.82	0.90	0.90	0.90	0.90	0.90	0.90	0.90	0.90	1.05

Twist Drill and Wire Gauge Nos.	40	41	42	43	44	45	46	47	48	49	50	51	52
Per lb.....	\$1.05	1.05	1.05	1.05	1.05	1.05	1.05	1.20	1.20	1.20	1.20	1.45	1.45

For Decimal sizes of Twist Drill Wire Gauge, see page 173.

MUSIC WIRE

In one pound rolls.

Music Wire Gauge Nos.	6	8	10	12	13	14	15	16	17
Size in Decimals0215	.0243	.027	.0296	.0314	.0326	.0345	.036	.0377
Per lb.	\$.....

Music Wire Gauge Nos.	18	19	20	21	22	23	24	26	28
Size in Decimals0395	.0414	.0434	.046	.0483	.051	.055	.0626	.072
Per lb.	\$.....

18 19 20
4.10 4.30 4.60
.....
5.70 6.00
7.00 7.20 7.40
32 33 34
11.00 12.00 13.00
.....

per 100 lbs. \$0.10
" 0.05
" 0.10
" 0.50
" 0.75
" 1.00
" 4.00

11 12 to 16
0.75 1.00
1.00 1.50
2.00 3.00

¼ ⅝ inch.

Galvanized Wire.
" "
8 17 18
30 9.10 9.40
years, and given

GALVANIZED POULTRY NETTING

PUT UP IN 50 LINEAL YARD ROLLS

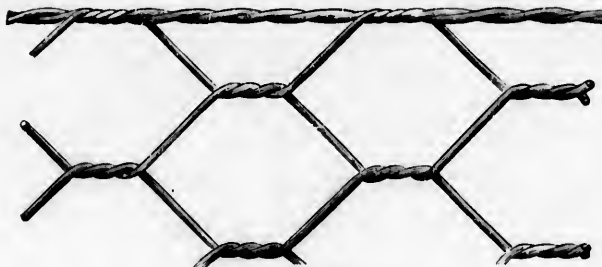

1 INCH MESH

Width	12	12	12	12	18	24	24	30	30	30	36	36	36	36	42	42	48	60	72	inch.
Mesh	1	1½	1½	2	2	1	2	¾	1	2	½	1	1½	1½	2	3	2	2	2	"
Gauge of Wire.	10	10	10	10	10	10	10	10	10	10	20	19	19	19	19	19	18	19	19	19
Per roll	\$3.10	2.45	2.05	1.50	2.25	6.30	3.00	11.00	7.85	3.75	21.00	9.45	7.50	6.10	4.50	5.25	5.10	6.00	7.50	9.00

McMULLEN'S WOVEN WIRE FENCING

GALVANIZED



LIST No. 1

Mesh 5½ x 10½ inches. Selvage No. 13, Meshes No. 14 Wire.

Width	25½	31	36½	42	47½	53	inch.
Per rod	\$0.54	0.57	0.60	0.63	0.66	0.69	

LIST No. 2

Mesh 5½ x 10½ inches. Selvage and Meshes No. 13 Wire.

Width	25½	31	36½	42	47½	53	inch.
Per rod	\$0.60	0.65	0.70	0.75	0.80	0.85	

LIST No. 3

Mesh 4 x 8 inches. Selvage No. 13, Meshes No. 14 Wire.

Width	22	26	30	34	38	42	46	50	54	inch.
Per rod	\$0.66	0.69	0.72	0.75	0.78	0.81	0.84	0.87	0.90	

LIST No. 4

Mesh 3 x 6 inches. Selvage No. 14, Mesh No. 15 Wire.

Width	30	23	26	29	32	35	41	47	59	71	77	inch.
Per rod	\$0.80	0.85	0.90	0.95	0.97	1.00	1.05	1.10	1.25	1.40	1.50	

20 Rods in a Roll, except 50, 71 and 77 inches wide, 3 x 6 inch Mesh; these are 10 Rod Rolls.

When ordering, give No. of List, width of goods and quantity required.

STEEL WIRE FOUNDRY BRUSHES



No. 1



No. 2



No. 3

No. 1—With Back Strap, 4 rows $3\frac{1}{2}$ inch Wire	per doz.	\$5.00
" 2—With Handles " " "	"	5.00
" 3—Round, $3\frac{1}{2}$ inch diameter, 4 inch Wire	"	5.50

MOULDERS' BRUSHES



SOFT BRUSH



HARD BRUSH

No. 6—Soft Brushes or Dusters	per doz.	\$10.05
" 7—Hard "	"	7.35

STEEL WIRE BROOMS



No. 5

No. 1—10 x $3\frac{1}{2}$ inch, 5 rows 5 inch Wire	per doz.	\$12.00
" 2—12 x 4 " 5 " 6 "	"	15.00
" 3—14 x $4\frac{1}{2}$ " 5 " 7 "	"	18.00
" 4—12 x $2\frac{1}{2}$ " 4 " 5 "	"	10.50
" 5—14 x $2\frac{1}{2}$ " 4 " 5 "	"	12.00

IRON TESTING MACHINE



No. 3

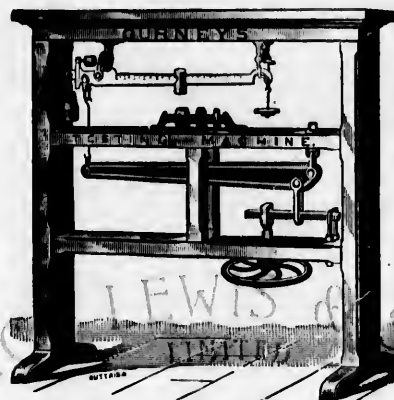

This machine is for the use of foundrymen in testing the strength of Cast Iron and ascertaining the best mixture of iron for any work. Specimens one inch square, fifteen inches long, may be cast and tested in a few minutes. By turning the hand-wheel below force is applied to the specimen, the force required being registered by the beam above as on a platform scale. The frame work is of oak. Capacity, 5,000 lbs.

Price.....each \$115.00

per doz. \$10.05
 " " 7.95

FIRE BRICK



"Ramsay" Fire Bricks per 1,000 \$.....
 American " " " "

FIRE CLAY

Best Imported Fire Clay, in bags about 200 lbs..... per ton \$15.00

per doz. \$12.00
 " " 15.00
 " " 18.00
 " " 10.50
 " " 12.00

MOULDERS' TOOLS



No. 10, BENCH LIFTER



No. 1, SQUARE TROWEL



No. 13, BEAD



No. 2, FINISHING TROWEL



No. 12, LIFTERS



No. 3, HEART-SHAPE TROWEL



No. 14, FLANGE AND BEAD



No. 4, HEART AND SQUARE



No. 7, TAPER AND SQUARE

For Prices
See opposite page.

MOULDERS' TOOLS

MONK'S

No. 1, SQUARE TROWELS

Length.....	4	4½	5	5½	6 inch.
1 inch wide, per doz.	\$6.75	7.50	8.25	9.00	9.75
1½ " " "	6.75	7.50	8.25	9.00	9.75
1¾ " " "	8.25	9.00	9.75	10.50	11.25
2 " " "	11.25	12.00	12.75
2 " " "	12.75	13.50	14.25

No. 2, FINISHING TROWELS

Length.....	5	5½	6 inch.
1½ inch wide.....per doz.	\$8.25	9.00	9.75
1¾ " " " " "	9.75	10.50	11.25

No. 3, HEART TROWELS

Width.....	2	2¼	2½	3 inch.
Per doz.....	\$7.50	8.40	11.25	15.00

No. 4, HEART AND SQUARE

Width.....	¾	1	1¼	1½	1¾	2 inch.
Per doz.....	\$6.00	6.75	8.25	9.75	11.25	12.75

No. 5, HEART AND LEAF

Width.....	1	1¼	1½ inch.
Per doz.....	\$6.75	8.25	9.75

No. 6, HEART AND SPOON

Width.....	1	1¼	1½ inch.
Per doz.....	\$6.75	8.25	9.75

No. 7, TAPER AND SQUARE

Width.....	¾	1	1¼	1½ inch.
Per doz.....	\$6.00	6.75	8.25	9.75

No. 8, TAPER AND SPOON

Width.....	1	1¼	1½ inch.
Per doz.....	\$6.75	8.25	9.75

No. 9, DOUBLE SQUARE

Width.....	½	¾	1 inch.
Per doz.....	\$6.75	7.50	8.25

No. 10, BENCH LIFTERS

Width.....	¾	1	1¼	1½ inch.
Per doz.....	\$6.00	6.75	7.50	8.25

No. 11, BENCH LIFTERS (BENT)

Width.....	¾	1	1¼	1½ inch.
Per doz.....	\$6.00	6.75	7.50	8.25

No. 12, LIFTERS

Length.....	10	12	14	16	18 inch.
¼ inch, per doz.	\$5.25	6.00	6.75	7.50
½ " " " " "	5.25	6.00	6.75	7.50
¾ " " " " "	6.00	6.75	7.50	8.25
1 " " " " "	6.75	7.50	8.25	9.00	9.75
1 " " " " "	8.25	9.00	9.75	10.50	11.25
1 " " " " "	9.00	9.75	10.50	11.25	12.00
1 " " " " "	11.25	12.00	12.75		

No. 13, BEAD

Width.....	½	¾	1 inch.
Per doz.....	\$6.75	7.50	8.25

No. 14, FLANGE AND BEAD

Width.....	½	¾	1 inch.
Per doz.....	\$10.50	12.00	13.50

No. 15, HUB TOOL

Width.....	¾	1 inch.
Per doz.....	\$11.25	13.50

No. 16, HALF ROUND CORNER

Width.....	1	1¼	1½	2 inch.
Per doz.....	\$7.50	7.50	7.50	7.50

No. 17, SQUARE CORNER

Width.....	2	2½	3 inch.
Per doz.....	\$7.50	7.50	7.50

No. 18, INSIDE SQUARE CORNER

Width.....	2	2½	3 inch.
Per doz.....	\$11.25	11.25	11.25

No. 19, BUTTON SLICK

Width.....	1¼	2	2½ inch.
Per doz.....	\$7.50	7.50	7.50

Size of all Tools where only one dimension is given is width of largest end.



No. 13, BEAD



NGE AND BEAD

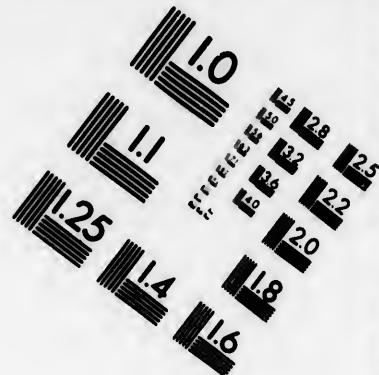
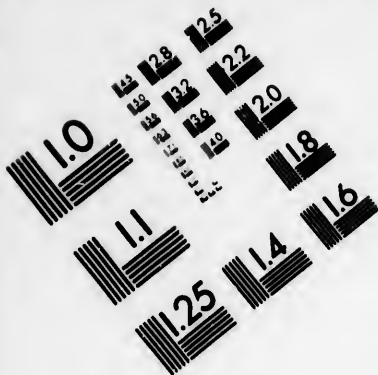

**IMAGE EVALUATION
TEST TARGET (MT-3)**

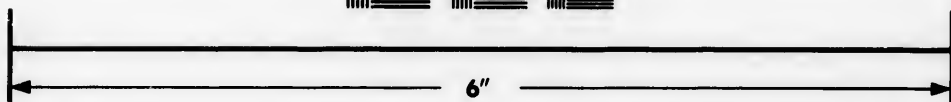
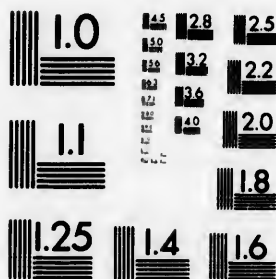

**Photographic
Sciences
Corporation**

23 WEST MAIN STREET
WEBSTER, N.Y. 14580
(716) 872-4503

18
20
22
25

01

CRUCIBLES

DIXON'S



Holding Capacity, three pounds of molten metal per number.

Nos	1	2	4	6	8	10	12	
Height outside	3½	4	5	5½	6½	7½	8	Inch.
Diameter at the top, outside	2½	2½	4	4½	5½	6	6½	"
" " bilge, "	2½	2½	4	4½	5½	6	6½	"
" " bottom, "	1½	1½	2½	2½	3½	4	5	"
Price	each	\$0.35	0.45	0.55	0.70	0.80	0.95	1.05

Nos	14	16	18	20	25	30	35	40	50	60	70	80	90	
Height outside	8½	8½	9½	10½	10½	11½	11½	12½	13½	14	14½	15½	15½	Inch.
Diam. at top, outside	6½	7½	7½	7½	8½	8½	9½	9½	10½	10½	10½	11½	11½	"
" " bilge, "	7½	7½	8½	8½	9	9½	9½	10½	11½	11½	12	12½	12½	"
" " bottom, "	5	5½	5½	6	6½	6½	7	7½	7½	8	8½	8½	9	"
Price	each	\$0.91	1.04	1.17	1.30	1.62½	1.95	2.27½	2.00	3.25	3.90	4.55	5.20	5.85



LUBRICATING GRAPHITE

In 1 lb. packages	per doz.	\$3.15
In 5 lb. screw-top tin cans	per tin	1.30

PLUMBAGO

In bulk	per lb.	0.30
---------	---------	------

FOUNDRY FACINGS

Charcoal Facings, in barrels about 250 lbs.	per barrel	\$.....
Lead " " " 250 "	"	"
Seacoal " " " 250 "	"	"

PORTLAND CEMENT

White's Best English Portland Cement, in barrels about 275 lbs.	per barrel	\$.....
Canadian " " " 275 "	"	"
Calced Plaster (Plaster of Paris) " " 275 "	"	"
Water Lime	"	"

LIFTING JACKS



TRAVERSING SCREW JACK

No. 37—Height when down 15 inches, Rise 10 inches, Horizontal Movement 15 inches, Weight 120 lbs., Capacity 8 tons...each \$107.25

No. 60—Height when down 18 inches, Rise 14 inches, Horizontal Movement 15 inches, Weight 140 lbs., Capacity 15 tons...each 123.25



TRAVERSING BASE

Suitable for any style of Jack.

No. 40—Horizontal movement 15 inches, Plate 10x12 inches, Weight 90 lbs., Capacity 25 tons.....each \$66.00

No. 43—Horizontal movement 15 inches, Plate 13x13 inches, Weight 180 lbs., Capacity 50 tons.....each 100.00

HYDRAULIC JACKS

Outside Pump Style.

Valves and Plunger Packing can be looked after without loosening Pump from casing. Working parts of Pump are entirely protected from dust.

In tripping, the valves are operated entirely by the lever and if for any reason the operator removes his hand from the lever while lowering the load, the valves close and the load stops.

Capacity Tons.	Rise Inches.	Height when down Inches.	Weight.	Price Each.
00	9	19	276 lbs.	\$313.50
00	12	22	304 "	338.25
00	18	28	360 "	387.75

The above Jacks to order only.

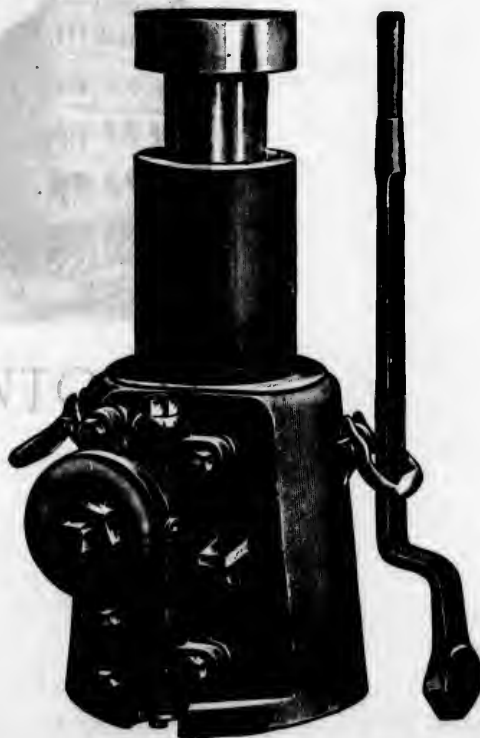

60 TON HYDRAULIC JACK

0 12
 1 8 inch.
 4 6 1/2 "
 5 5 "
 1.05
 80 90
 15 1/2 15 1/2 inch.
 11 1/4 11 1/4 "
 12 1/2 12 1/2 "
 8 9 "
 3.20 5.85

per doz. \$3.15
 per tin 1.30

per lb. 0.30

barrel \$.....

barrel \$.....

JACK SCREWS



Nos. 3 and 5



No. 17



No. 18

CAST IRON STAND, WROUGHT IRON SCREW, SQUARE THREAD

No.	DESCRIPTION.	Diameter of Screw.	Height of Stand and Length of Screw.	Height over all when screwed down.	Weight.	Price each.
1	Wide Flange Base, one handle	2	13	19	54	\$ 8.00
3	Wide Bell Bottom, " "	1½	9½	14	27	5.50
5	" " two " "	2½	15	21½	70	12.00
9	Bottle Pattern one " "	2	19	25½	60	9.50
17	Bell Bottom " "	1½	12	16	23	5.00
18	" " " "	2	12	18	38	7.25

LEVER JACKS



The Frame and Pawl, Malleable Iron; the Bar and Lever, Steel Forging; Milled Teeth, Steel Pins and Hardened Bearings.

Nos.	2	4	5	6
Height of Jack	19	22	26½	20½ inches.
Rise of Bar	11	18	15	14
Weight of Jack	27	46	83	100 lbs.
Capacity	2	4	10	15 tons.
Each	\$16.50	26.40	38.00	43.00

ALBANY JACKS



No. 4A—Height 30 inches, Rise of Bar 20 inches, Weight 60 lbs., Capacity 6 tons.....each \$22.50

THE HYPER-ACME

PULLEY BLOCKS

The friction in this block is automatically cut off as the load rises, and consequently only the load being raised need be reckoned on, thereby reducing the power required by more than one-half.

The ordinary screw block has only the single worm and that of a very fine pitch, thus making the process of raising very slow, where as in the "Hyper Acme" Pulley Block the worm is of very coarse pitch, causing the load to rise with great speed.

The lowering of light or heavy weights is done with ease and rapidity.

The screw is cut by special machinery to fit exactly the radius of the wheel, thereby adding very materially to the long life and safety of the block. Each block is tested to 50 per cent. above the nominal power it is sold for. One man can lift any weight up to 10 tons with far greater ease and very much quicker than with the ordinary pulley blocks.



TORONTO, ONT.

PRICES

Nominal Power	tons	1/2	1	1 1/2	2	3	4	5	10
Tested to	"	3/4	1 1/2	2 1/2	3	4 1/2	6	7 1/2	15
With Chain to Lift 12 feet, each		\$36.00	41.50	49.00	62.00	77.00	90.25	108.75
" " 15 " "		64.80	80.00	93.05	113.00
" " 20 " "		120.00	273.00
Hand Chain Wheels		3.75	4.00	5.00	6.25	7.50	8.75

20 inches,
..... each \$22.50

PATENT EPICYCLOIDAL PULLEY BLOCKS

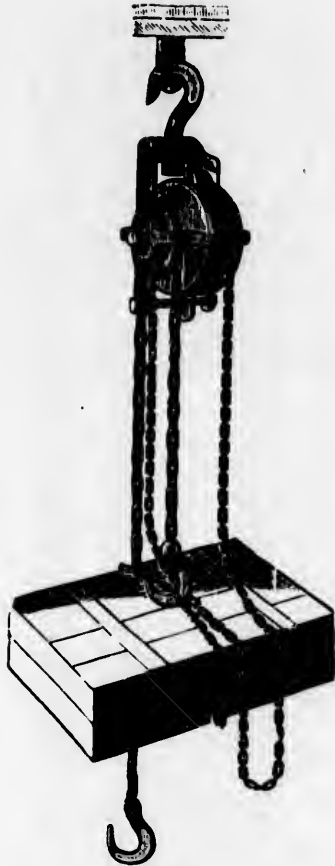

No. 1

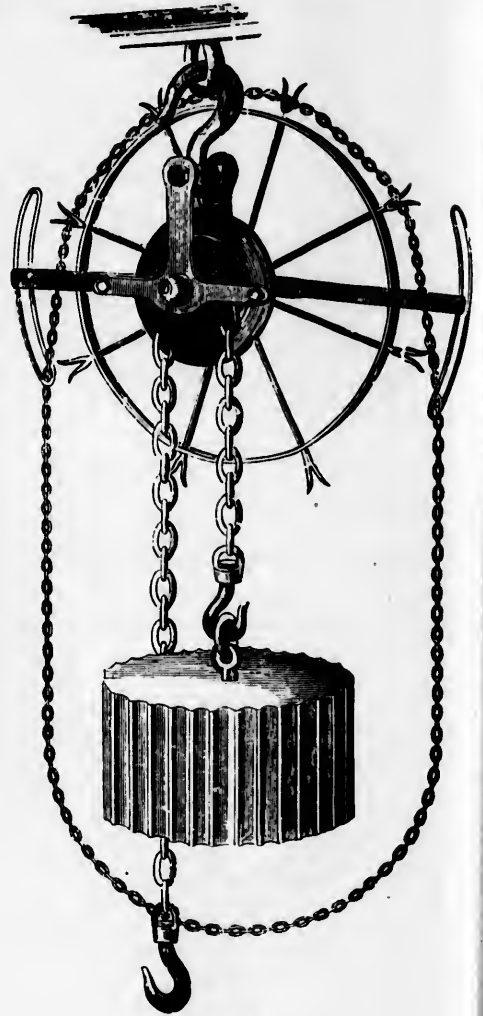

No. 3

One man can lift a ton with a set of Ton Blocks. 130 lbs. force required to lift 2240 lbs.

The ratio of speed of Hand and Load Chain is 37 to 1.

Tested to.....	¼	½	1	1½	2	3 tons.
No. 1, to lift 12 feet, including Hand and Lifting Chain.....each	\$13.50	16.20	24.35	29.50	34.75	50.00
Tested to				3	4	5 tons.
No. 3, fitted with Sprocket-Wheel and Guides, to lift 15 feet				\$66.35	81.50	107.00

DIFFERENTIAL PULLEY BLOCKS

WESTON'S IMPROVED

With Chain Guides, which prevent the troublesome locking of chains, and enable the block to be used horizontally or at any desired angle.

With 40 feet of Chain to each.

Tested to	¼	½	1	1½	2	3	4 tons.
Each	\$9.10	10.75	15.00	19.00	22.85	28.85	37.50

ADDITIONAL CHAIN

Size	¼	½	1	1½	2	3	4 tons.
Per 100 feet	\$19.20	19.20	26.00	30.00	34.50	38.40	42.20

TOP SHEAVES FOR DIFFERENTIAL BLOCKS

Size	¼	½	1	1½	2	3	4 tons.
Each	\$1.20	1.40	2.20	2.95	5.30	5.75	7.20



HOISTING CRAB OR WINCH

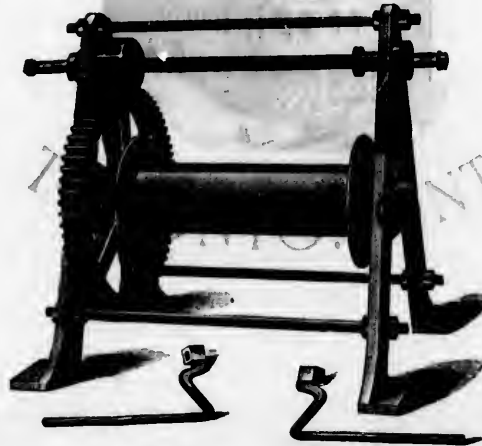

Turned Shafts, the Bearings accurately bored, steel keyed.

No. 1—Weight 550 lbs., Capacity 4 tons each \$50.00

Post and Derrick Winches and other sizes of Crab Winches to order.

2240 lbs.

2 3 tons.
34.75 50.00

4 5 tons.
81.50 107.00

SURE-GRIP STEEL TACKLE BLOCKS



Instructions for Reeing

Enter rope at A, pass wedge, and follow arrows as shown in cut. It will be noticed that the two centre ropes coming in contact with wedge always travel in same direction at same time. Take twist out of rope.

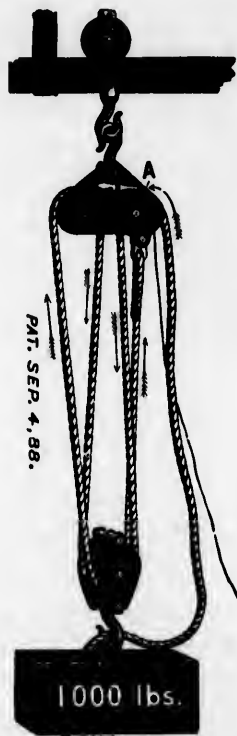

Nos. 3, 4, 5 and 6

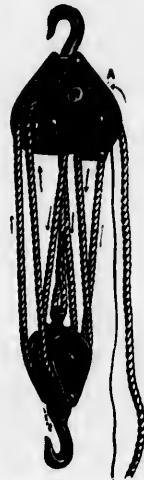

Nos. 4½, 5½ and 6½

These blocks will hold the load at any point without fastening the rope. The break is simply a wedge that drops by gravity between the upper sheaves and is absolutely automatic in its action. The face of the wedge is fluted in such a manner that the rope is not worn more than by an ordinary block. There is no back slip, which greatly reduces the effort of lifting. The blocks can be operated from any position.

No. 3—	To be used with	$\frac{3}{8}$ inch rope,	one man can lift	300 lbs.,	capacity	600 lbs.	each	\$ 3.00
" 4—	"	"	"	350 "	"	1000 "	"	5.50
" 4½—	"	"	"	500 "	"	1200 "	"	10.00
" 5—	"	"	"	400 "	"	1800 "	"	7.00
" 5½—	"	"	"	600 "	"	2000 "	"	12.00
" 6—	"	"	"	450 "	"	2500 "	"	8.50
" 6½—	"	"	"	850 "	"	4000 "	"	14.00

Blocks Nos. 3, 4, 5 and 6 require rope 5 times, and Nos. 4½, 5½ and 6½, 7 times the height to be lifted. The above prices include upper and lower blocks only. Rope Extra.

Test of Sure-Grip Blocks

Nos.....	3	4	5	6	6½
Tested without breaking to.....	2800	3900	4500	5900	9000 lbs.
Capacity claimed.....	600	1000	1800	2500	4000 "

TRACK TROLLEYS

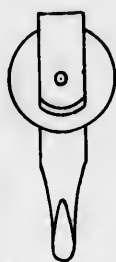

SINGLE

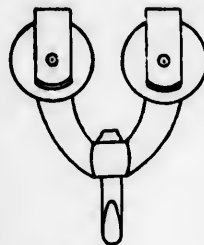

DOUBLE

Size of Sheave	2 1/2	3 1/2	4 1/2 inch.
Single Trolleys.....	\$1.00	3.35	6.20
Double ".....	9.50	11.40	15.20

RICE, LEWIS & SON



No. 879

THE "EDDY" TACKLE BLOCKS

Forged Steel Shells.

Each Block has a Becket.

Size	3 1/2	4	5	6	8 inch.
For Rope.....	1	1	1	1	1 "
Single.....each	\$0.75	0.85	0.90	1.10	1.65
Double....."	1.45	1.60	1.75	2.00	2.85



No. 880

TORONTO, ONT.

SNATCH BLOCKS

LOCKPORT PATTERN No. 177

Steel Shell, Iron Sheave, Japanned.

Length of Shell	7	8	10	12	14	16 inch.
For Rope.....	1	1 1/2	1 1/2	1 1/2	2	"
Each.....	\$5.50	7.00	9.00	11.50	15.00	20.00

GIN BLOCKS

With Wrought Iron Frame, Swivel Hooks.

Diameter of Wheel...	12	14	16	18 inch.
For Rope.....	1	1 1/2	1 1/2	1 1/2 "
Each.....	\$4.30	4.00	6.40	6.00



No. 177, SNATCH BLOCK



GIN BLOCK

5 1/2 and 6 1/2

simply a wedge that
face of the wedge is
no back slip, which

.....each	\$ 3.00
....."	5.50
....."	10.00
....."	7.00
....."	12.00
....."	8.50
....."	14.00

e lifted. The above

6	6 1/2
5800	9000 lbs.
2500	4000 "

WROUGHT IRON TACKLE BLOCKS

LONDON PATTERN



SNATCH BLOCK

For Rope.....		$\frac{3}{8}$	$\frac{1}{2}$	$\frac{3}{4}$	1	1 $\frac{1}{4}$	1 $\frac{1}{2}$	1 $\frac{3}{4}$	2 inch.
One Sheave.....	each	\$1.30	1.85	1.95	2.80	2.75	3.50	4.00	7.35
Two ".....	"	1.85	2.15	2.65	3.50	4.25	5.90	8.30	11.80
Three ".....	"	2.20	2.65	3.50	4.80	5.90	8.10	11.80	15.65
Snatch.....	"	2.40	3.15	3.70	4.00	5.00	8.85

"STAR" STEEL TACKLE BLOCKS



Size.....		4	5	6	7	8 inch.
For Rope.....		$\frac{1}{2}$	$\frac{3}{4}$	$\frac{1}{2}$	$\frac{1}{2}$	1 "
One Sheave.....	each	\$0.90	1.00	1.25	1.50	1.85
Two ".....	"	1.75	1.90	2.25	2.70	3.20
Three ".....	"	2.50	2.75	3.25	4.00	4.75

TACKLE BLOCKS



HATCH BLOCK

1 1/4	2	inch.
4.00	7.35	
8.90	11.90	
1.80	15.05	
5.90	8.85	



SINGLE WITH BECKET



DOUBLE WITH BECKET

Regular Inside Iron Strapped Blocks, Loose Hooks and Becketts, Iron Sheaves.

Size of Shell	3	3 1/2	4	5	6	7	8	9	10	inch.
For Rope	1	1 1/2	2	3	4	5	6	7	8	"
Single	each \$0.70	0.75	0.85	0.90	1.10	1.30	1.05	1.85	2.75	
Double	" 1.30	1.45	1.00	1.75	2.00	2.40	2.85	3.40	4.50	

PATENT ROLLER BUSHED

Inside Iron Strapped Blocks, Loose Hooks and Becketts.

Size of Shell	3	3 1/2	4	5	6	7	8	9	10	inch.
For Rope	1	1 1/2	2	3	4	5	6	7	8	"
Single	each \$1.10	1.15	1.20	1.25	1.50	1.70	2.25	2.50	3.50	
Double	" 2.00	2.20	2.25	2.35	2.85	3.35	4.15	4.70	6.00	

BLOCKS FOR ROPE STRAPS

SHELLS RIVETTED, IRON SHEAVES



SINGLE



DOUBLE

Size of Shell	2	3	4	5	6	inch.
For Rope	1	1 1/2	2	3	4	"
Single	each \$0.22	0.28	0.30	0.45	0.54	
Double	" 0.40	0.48	0.60	0.82	0.90	



PATENT STEEL ROLLER BUSHINGS

WITH RIVETTED SEPARATOR

Hole or Pin	1/2	5/8	inch.
Each	\$0.50	0.70	

8	inch.
1	"
1.85	
3.20	
4.75	

CAST IRON WHEELS

FOR TRANSMISSION OF POWER BY WIRE ROPES

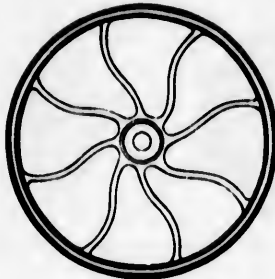

SKETCH OF WHEEL

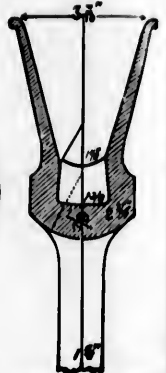

SECTION OF RIM OF 6 FT. WHEEL

PRICE OF WHEELS

Bored to Fit Shaft, and lined with Leather Filling.

Diameter.....	2	2½	3	3½	4	5	6	7	8	feet.
Each.....	\$18.00	20.00	22.50	24.00	36.00	48.00	72.00	85.00	126.00	

Special prices for larger sizes.

Table of Transmission of Power by Wire Ropes

Showing the necessary size and speed of wheels and rope to obtain any desired amount of power.

Diameter of Rope.....	¼	½	¾	¾	1½	1½	1½	1½	1½	¾	¾	¾	¾	¾	inch.
Diameter of Pulley.....	3	3	4	4	5	5	6	6	6	7	7	7	8	8	feet.
Number of Revolutions.....	100	140	100	120	100	120	100	120	140	80	100	120	80	100	
Horse Power.....	2	3	4	5	8.6	10.3	13.4	16.1	18.7	16.9	21.1	25.3	22	27.5	

CAST IRON SHEAVES



WITH PATENT ROLLER BUSHINGS

Diameter.....	1¼	2	2¼	3	3½	4¼	4¼	5½	6	inch.
Thickness.....	½	½	¾	¾	1	1	1¼	1¼	1¼	"
Size of Hole.....	½	½	¾	¾	1	1	1¼	1¼	1¼	"
Black..... each	\$0.50	0.55	0.60	0.65	0.80	0.90	1.15	1.25	1.50	
Galvanized..... "	0.55	0.60	0.65	0.75	0.96	1.10	1.30	1.45	1.90	

CAST IRON SHEAVES

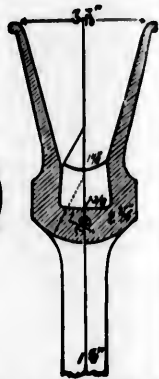

OF RIM OF 8 FT. WHEEL



FOR ROPE

Diameter	1 1/4	2	2 1/4	2 3/4	3	3	3 1/2	3 3/4	4	4 1/4	4 1/2	inch.
Thickness	1 1/4	1 1/2	1 3/4	1 3/4	1 3/4	1 3/4	1 3/4	1 3/4	1 3/4	1 3/4	1 3/4	"
Size of Hole	1 1/4	1 1/2	1 3/4	1 3/4	1 3/4	1 3/4	1 3/4	1 3/4	1 3/4	1 3/4	1 3/4	"
Black	each \$0.08	0.08	0.07	0.07	0.00	0.10	0.12	0.10	0.18	0.10	0.21	0.28
Diameter	4 1/4	5	5 1/4	5 1/2	6	6 1/4	6 1/2	7	7	8	8	inch.
Thickness	1 1/4	1 1/2	1 3/4	1 3/4	1 3/4	1 3/4	1 3/4	1 3/4	1 3/4	1 3/4	1 3/4	"
Size of Hole	1 1/4	1 1/2	1 3/4	1 3/4	1 3/4	1 3/4	1 3/4	1 3/4	1 3/4	1 3/4	1 3/4	"
Black	each \$0.08	0.90	0.54	0.90	0.48	0.54	0.70	0.80	0.75	1.30	1.80	

FOR CHAIN

Diameter	6	6	8	10	12	inch.
Thickness	1 1/4	1 1/4	1 1/2	2	2 1/2	"
Size of Hole	1 1/4	1 1/4	1 1/2	1	1	"
For Chain	1 1/4	1 1/4	1 1/2	1 1/2	1 1/2	"
Black	each \$0.50	0.70	1.30	2.25	3.00	

Japanned, with Turned Grooves and Bored Pin Holes. Under 3 1/2 inch are solid, others like cut.

CLOTHES LINE PULLEYS

WELL WHEELS

of power.

5 1/2	5	5	inch.
7	8	8	feet.
120	80	100	
25.3	22	27.5	



No. 65, 2 1/2 Inch



No. 1, CAST IRON, JAPANED

No. 65-2 1/2 inch, Japanned	per doz.	\$0.70	Size	8	10	12	14	inch.
" 165-2 1/2 "	"	1.45	No. 1	Per doz.	\$3.40	4.50	5.65	9.75
One dozen in a box.								

HAY FORK PULLEYS

SWIVEL EYE



No. 433



No. 565



No. 384

No. 433—Cast Frame Pulley, 6 inch Maple Sheave, 1 inch Self-Lubricating Pin	per doz.	\$2.50
" 565—Steel " " 5½ " Cast Iron Sheave, revolving on a large Axle.....	"	2.70
" 384—Cast " " 6 " Maple Sheave, 1 inch Self-Lubricating Pin.....	"	3.00



No. 709



Nos. 1 and 11

No. 709

"Hartz" Self-Oiling, Steel Shell, Wrought Iron Swivel Ring, Sheave 4½ inch diameter, 1½ inch wide.

No. 709.....	per doz.	\$3.00
--------------	----------	--------

Nos. 1 and 11

Japanned, Extra Strong and Smooth Running, Sheave 5 inch diameter for 1 inch Rope.

No. 1—Stationary Eye.....	per doz.	\$2.70
" 11—Swivel Eye.....	"	3.00

JAPANNED SIDE PULLEYS



No. 25, $\frac{3}{4}$ inch



No. 25, $1\frac{1}{4}$ inch

Size.....	1	$1\frac{1}{4}$	$1\frac{1}{2}$	$1\frac{3}{4}$	2	$2\frac{1}{4}$	$2\frac{1}{2}$ inch.
No. 25.....	per doz.	\$0.72	0.78	0.80	0.98	1.30	1.70 2.00

2 inch and smaller, two dozen in a box; $2\frac{1}{4}$ and $2\frac{1}{2}$ inch one dozen.

UPRIGHT PULLEYS



No. 55

HOT HOUSE PULLEYS

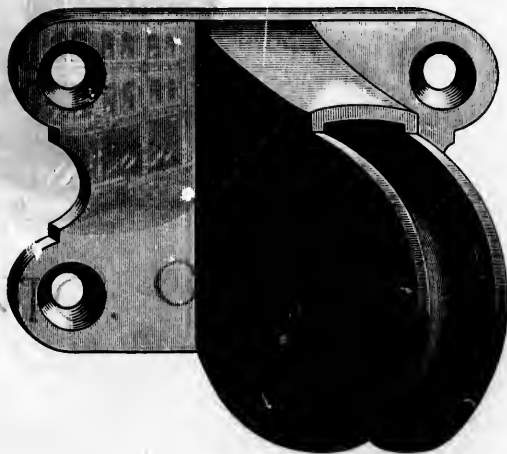

No. 85, $1\frac{1}{4}$ inch

No. 55— $1\frac{1}{2}$ inch, Japped.....	per doz.	\$0.90	No. 85— $1\frac{1}{4}$ inch, Japped.....	per doz.	\$1.70
" 55-2 " "	"	1.05	" 85-2 " "	"	2.00

Two dozen in a box.

One dozen in a box.

BRASS SCREW PULLEYS

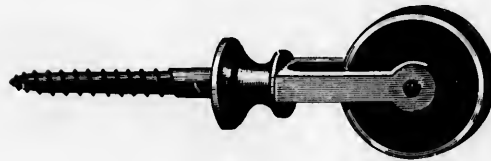

Size		$\frac{1}{2}$	$\frac{5}{8}$	$\frac{3}{4}$	$\frac{7}{8}$	1	1 $\frac{1}{4}$	1 $\frac{1}{2}$ inch.
No. 274—Single	per doz.	\$0.57	0.75	0.90	1.10	1.50	2.20	3.00
" 284—Double	"	1.50	1.90	2.20	2.55	3.00

JAPANNED SCREW PULLEYS

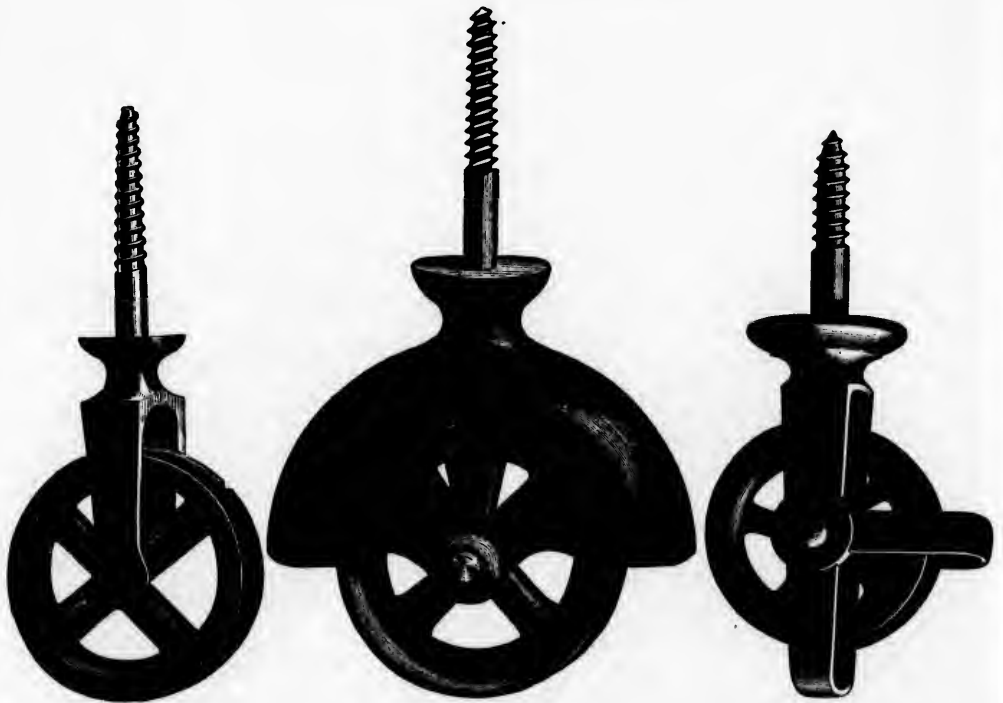

No. 45, 1 $\frac{1}{2}$ Inch

No. 43, 2 Inch

No. 46, 1 $\frac{1}{2}$ Inch

Size		1 $\frac{1}{2}$	1 $\frac{3}{4}$	2	2 $\frac{1}{4}$	2 $\frac{1}{2}$	3 inch.
No. 45	per doz.	\$0.55	0.68	0.90	1.10	1.30
" 43	"	1.80	2.40
" 46	"	1.10

No. 45, 1 $\frac{1}{2}$ to 2 $\frac{1}{4}$ inch, two dozen in a box; others one dozen.

TACKLE OR AWNING PULLEYS

WITH SCREW EYE

No. 71, JAPANNED

With Bright Wire Screw Eye.

Size	1/2	5/8	3/4 inch.
Per dozen	\$0.53	0.68	0.78

No. 171, GALVANIZED

With Brass Screw Eye.

Size	1/2	5/8	3/4 inch.
Per dozen	\$0.80	1.00	1.10



Nos. 71 and 171, 1/2 inch



Nos. 71 and 171, 3/4 inch



Nos. 73 and 173, 1/2 inch



Nos. 73 and 173, 1 1/2 inch



Nos. 73 and 173, 1 1/4 inch

SWIVEL EYE

No. 73, JAPANNED

Size	1/2	5/8	3/4	1	1 1/4	1 1/2	1 3/4	2 inch.
Per dozen	\$0.50	0.00	0.80	1.00	1.10	1.00	2.40	3.20

No. 173, GALVANIZED

Size	1/2	5/8	3/4	1	1 1/4	1 1/2	1 3/4	2 inch.
Per dozen	\$0.75	0.85	1.10	1.30	1.80	2.40	3.70	4.80

2 inch, half-dozen in a box ; other sizes, one dozen.

RICE LEWIS & SON
LIMITED

TOMMY HORN

1 1/4 1 1/2 inch.
2.20 3.00
.....

1 1/2 inch
30
80 2.40
.....

TACKLE OR AWNING PULLEYS

(Not Swivel Eye.)



Nos. 74 and 174, $\frac{1}{2}$ Inch



Nos. 74 and 174, $\frac{3}{4}$ Inch



Nos. 74 and 174, $1\frac{1}{2}$ Inch

SINGLE No. 74, JAPANNED

Size	$\frac{1}{2}$	$\frac{3}{4}$	1	$1\frac{1}{4}$	$1\frac{1}{2}$	$1\frac{3}{4}$	2	$2\frac{1}{2}$ inch.
Per dozen	\$0.40	0.60	0.70	0.80	1.00	1.30	1.80	3.50

SINGLE No. 174, GALVANIZED

Size	$\frac{3}{4}$	1	$1\frac{1}{4}$	$1\frac{1}{2}$	$1\frac{3}{4}$	2	2 inch.
Per dozen	\$0.85	1.00	1.30	1.80	2.60	4.00	

DOUBLE No. 76, JAPANNED

Size	$\frac{3}{4}$	1	$1\frac{1}{4}$	$1\frac{1}{2}$	$1\frac{3}{4}$	2	2 inch.
Per dozen	\$0.85	1.00	1.10	1.60	2.40	3.70	

DOUBLE No. 176, GALVANIZED

Size	$\frac{3}{4}$	1	$1\frac{1}{4}$	$1\frac{1}{2}$	$1\frac{3}{4}$	2	2 inch.
Per dozen	\$1.30	1.60	1.80	3.00	4.80	6.00	

SINGLE No. 75, JAPANNED

2 inch, with Eye at each end.....per doz. \$1.00

2 inch, half-dozen in a box; other sizes, one dozen.

GALVANIZED TACKLE BLOCKS

With Loose Wrought Iron Hooks.



Length of Shell	3	$3\frac{1}{2}$	4
Size of Sheave	$1\frac{1}{2} \times \frac{1}{2}$	$2 \times \frac{1}{2}$	$2\frac{1}{2} \times \frac{1}{2}$
No. 429—Single.....each	\$0.43	0.48	0.75
" 430—Double	0.50	0.60	0.95

DECK HALYARD BLOCKS

GALVANIZED IRON

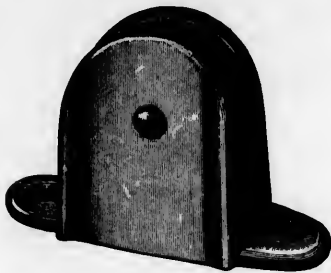

No. 449, Single

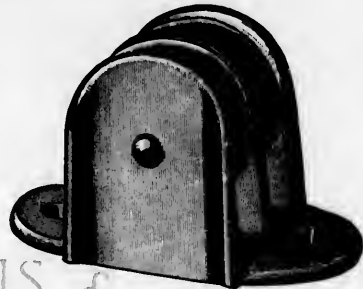

No. 450, Double

No. 449—Sheave 1½ x ½ inch.....	each \$0.25	No. 450—Sheave 1½ x ½ inch.....	each \$0.50
" 449— " 2 x ¾ "	" 0.50	" 450— " 2 x ¾ "	" 1.00

GALVANIZED SNATCH BLOCKS

MALLEABLE IRON



No. 451, With Plate



No. 452, With Eye

No. 451—Sheave 1½ x ¾ inch.....	each \$0.25	No. 452—Sheave 1½ x ¾ inch.....	each \$0.20
" 451— " 1½ x ½ "	" 0.35	" 452— " 1½ x ½ "	" 0.25

GALVANIZED TURNBUCKLES



No. 225, PIPE TURNBUCKLES

Diameter of Screw.....	¼	⅜	½	⅝	¾ inch.
No. 225.....each	\$1.00	1.10	1.30	1.50	1.80



No. 221, TURNBUCKLE WITH HOOK AND EYE

Diameter of Screw.....	¼	⅜	½	⅝	¾	1	1½ inch.
No. 221.....each	\$1.00	1.10	1.30	1.50	1.80	2.10	2.40 3.50 4.25 5.50 7.00



174, 1½ inch
 2 2½ inch.
 1.80 3.50
 1¾ 2 inch.
 2.60 4.00
 1¾ 2 inch.
 2.40 3.70
 1¾ 2 inch.
 4.80 6.00
per doz. \$1.00

3½ 4 inch.
 2 x ¾ 2½ x ¾ "
 0.48 0.75
 0.60 0.95

GALVANIZED GROMMET RINGS

LIGHT

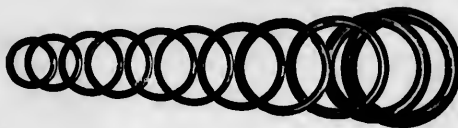

Size		$\frac{3}{8}$	$\frac{1}{2}$	$\frac{5}{8}$	$\frac{3}{4}$	$\frac{7}{8}$	1	1 $\frac{1}{4}$ inch
No. 601.....	per gross	\$0.35	0.40	0.45	0.65	0.85	1.15	2.00

MAST HOOPS



Made of $\frac{1}{4}$ inch Galvanized Iron.

Measure in clear.....		2	3	4	5	6 inch.
No. 275.....	per doz.	\$0.50	0.80	0.85	1.10	1.30
Yacht Mast Hoops, Copper Rivetted, all sizes, 3 to 14 inch.	per inch	\$0.04				

SHEET BRASS WASHER GROMMETS



Size.....	Nos.	0	1	2	3	4	inch.
Size of Hole.....		$\frac{1}{8}$	$\frac{1}{4}$	$\frac{3}{8}$	$\frac{1}{2}$	$\frac{3}{4}$	"
No. 604... per gross		\$0.50	0.80	1.10	1.50	2.50	

TENT HOOKS AND EYES

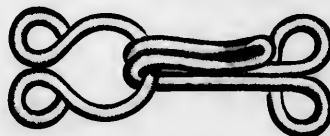

No. 1300—Brass	per gross	\$2.70
No. 1306—Galvanized	"	1.15

INSERTING DIES



Inserts Sheet Brass Washer and Teeth Grommets.

For Nos.....		0	1	2	3	4
No. 690.....	each	\$3.00	3.25	3.40	3.55	3.75

MARLINE SPIKES



TEMPERED STEEL, POLISHED

Size..... 10 12 inch.
 No. 632..... per doz. \$6.00 7.50

STEEL POINTS, JAPANESE

Size..... 8 10 inch.
 No. 635..... per doz. \$2.70 4.50

1 1 1/4 inch
 1.15 2.00

CAULKING IRONS

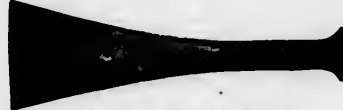

No. 640, CAULKING IRONS

No. 641, DUMB IRONS

Nos.....	640	640	640	641
Crease.....	0	1	2	3
Thickness.....			 inch.
Per dozen.....	\$6.75	6.90	7.15	7.30 7.90
Klondike Boat Caulking Irons, total length 5 inches, crease 1/4 inch thick, 2 inches wide per doz. \$5.25				

CAULKING MALLET AND BEETLES



No. 638, CAULKING MALLET

No. 639—HAWGING BEETLES

No. 638—Live Oak per doz. \$28.00

No. 639—Live Oak per doz. \$30.00

5 6 inch.
 1.10 1.90
 per inch \$0.04

D EYES



..... per gross \$2.70
 " 1.15

SHIP SCRAPERS



No. 649—Blades 1/4 inch thick, 5 inch cut per doz. \$5.65

FOG HORNS

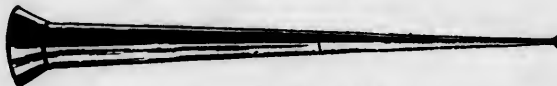

WOOD MOUTHPIECE

Length.....
 No. 650..... per doz. \$9.45 11.85 16.50

2 3 4
 40 3.55 3.75

GALVANIZED THIMBLES



ROUND



HEART SHAPE

		ROUND						
Diameter (edge to edge)		$\frac{3}{4}$	1	1 $\frac{1}{4}$	1 $\frac{1}{2}$	2	2 $\frac{1}{4}$	2 $\frac{1}{2}$ inch.
No. 588	per doz.	\$0.25	0.35	0.40	0.45	0.60	0.70	0.80
		HEART SHAPE						
Width of Score		$\frac{5}{8}$	$\frac{1}{2}$	$\frac{3}{4}$	$\frac{1}{2}$	$\frac{3}{4}$	$\frac{7}{8}$	1 inch.
For Wire Rope, circumference		1	1 $\frac{1}{4}$	2	2 $\frac{1}{4}$	2 $\frac{3}{4}$	3	"
No. 594	per doz.	\$1.20	1.45	1.55	1.70	2.35	2.60	

GALVANIZED HOOKS AND THIMBLES



No. 328



No. 329

Size		$\frac{1}{4}$	$\frac{3}{8}$	$\frac{1}{2}$	$\frac{5}{8}$	$\frac{3}{4}$ inch.
No. 328—Hooks and Thimbles	per doz.	2.25	2.55	2.95	3.65	4.80
" 329— $\frac{1}{4}$ -inch Sister or Match Hooks	per doz.					\$3.40

Measure diameter of Hook at largest part.

THE CROSBY WIRE ROPE CLIP



Are the most effective Wire Rope Fastenings in the market.

Diameter of Rope		$\frac{3}{8}$	$\frac{1}{2}$	$\frac{5}{8}$	$\frac{3}{4}$ inch.
Price	each	\$0.40	0.45	0.55	0.60

WIRE ROPE SOCKETS



No. 590



No. 591

Size		$\frac{3}{8}$	$\frac{1}{2}$	$\frac{5}{8}$	$\frac{3}{4}$ inch.
No. 590—Black	per doz.	1.80	2.00	2.25	2.85
" 591— "	"	2.20	2.50	3.15	3.75

GAFF-TOPSAIL HOOKS

GALVANIZED SELF-MOUSING

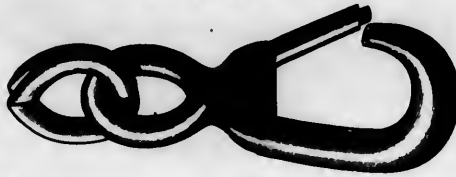

No. 338— $\frac{1}{4}$ inch with Thimbles..... per doz. \$7.80
 " 338— $\frac{1}{4}$ " without Thimbles..... " 6.85

GALVANIZED JIB HANKS

GALVANIZED S. HOOKS



Size inside 1 1 $\frac{1}{4}$ 1 $\frac{1}{2}$ 2 inch. | Size..... $\frac{1}{4}$ $\frac{5}{16}$ $\frac{3}{8}$ inch.
 No. 573-Single Stay, per doz. \$0.65 0.70 0.75 0.90 | No. 349..... per doz. \$0.50 0.65 0.95

GALVANIZED CHAIN SHACKLES



No. 217, with Pin

No. 215, with Screw

Size..... TORONTO, ONT.
 No. 217—With Pin..... per doz. $\frac{1}{4}$ $\frac{5}{16}$ $\frac{3}{8}$ $\frac{1}{2}$ inch.
 " 215—With Screw..... 2.75 2.75 3.00 4.00
 " 215—With Screw..... 3.00 3.00 3.25 4.50

GALVANIZED BOOM BANDS



No. 258

No. 267

Size.....
 No. 258.....each \$0.90 1.05 1.25 1.40 | No. 266—3 inch Boom Bands with Traveller..each \$1.25
 " 266—4 " " " " 1.60
 " 267—5 " " adjustable..... " 5.25

GALVANIZED CHOCKS



No. 313



No. 311

Entire Length.....	3	3 1/2	4	4 1/2	5	5 1/2	6 1/2	7 1/2	8 1/2	10 1/2 inch.
No. 313—Straight..... per single doz.	\$1.10	1.45	1.80	2.30	2.55	4.00	5.80	8.70	9.50	
1" 311—Bow Chocks..... per dozen pair	1.80		2.20		3.60					

10 11
0 7 inch.
2.50 3.00
..... per doz. \$4.50
..... " 9.00

SOCKET OAR LOCKS MALLEABLE IRON



RICE LEWIS & SON
LIMITED

Nos.....	10	11	12
Size between Horns.....	1 1/2	2	2 1/2 inch.
No. 294—Galvanized..... per dozen pair	\$4.50	5.25	7.50

..... per doz. 10.66

MALLEABLE IRON TINNED OAR LOCKS



No. 1



No. 2



No. 4

TORONTO, ONT.

No. 1—2 1/2 inch opening.....										
" 2—2 1/2 " ".....										per dozen pair \$6.00
" 4—2 1/2 " ".....										6.00
										7.20

..... per doz. 0.00
..... " 0.90

WATER DECK IRONS

For the Protection of Decks, Floors and Partitions against Fires from Heated Stove Pipes.



GALVANIZED

Size.....	3	4	5	6 inch.
Each.....	\$1.05	1.35	1.75	2.30

PLAIN

Size.....	3	4	5	6 inch.
Each.....	\$0.70	0.95	1.35	1.70

The sizes indicate openings for pipe.

CHAIN DECK PIPES

GALVANIZED

Size.....	1 1/4	2	2 1/4	2 1/2	3 inch.
For Chain	1/4	1/2	3/4	1	"
Each.....	\$0.75	0.85	0.95	1.10	1.25



BRASS SIDE LIGHTS



Diameter of Glass in the Clear.....	5	6	7	8 inch.
" " Opening in Flange.....	6	7	8	9
No. 618—Round Flange.....	\$4.00	6.00	8.00	9.00
" 620— " ".....	9.00	11.00	14.00

ve Pipes.

5 6 inch.
1.75 2.30

5 6 inch.
1.85 1.70
gs for pipe.

SAILORS' PALMS



No. 2—Hide Mounted.....per doz. \$3.50

SAIL NEEDLES

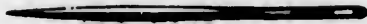

Length..... 2 2½ 3 3½ inch.
No. 2402.....per 100 \$0.40 0.55 0.75 0.95

RICE, LEWIS & SON
LIMITED

PACKING NEEDLES



Length..... 3 3½ 4 5 6 inch.
No. 2403.....per gross \$1.00 1.05 1.15 1.40 1.75

COLLAR NEEDLES



Length..... 5 6 inch.
No. 2404.....per gross \$2.10 2.30

TORONTO, ONT.

UPHOLSTERERS' NEEDLES



DOUBLE POINTED

Length..... 10 12 14 inch.
No. 2410.....per gross \$7.65 12.00 17.10

STEEL KNITTING NEEDLES



Nos..... 8 9 10 11 12 13 14 15 16
B. W. Gauge..... 13 14 15 16 17
No. 2421—Tapered.....per gross \$0.80 0.75 0.70 0.60 0.55 0.50 0.45 0.40 0.40

7 8 inch.
8 9
8.00 9.00
14.00

GALVANIZED BOAT HOOKS



No. 352X1—For 1½ inch Pole..... per doz. \$4.85
 " 352X2— " 1½ " " 6.50

SCREW RUDDER BRACES



Opening between Straps..... ½ ¾ 1 inch.
 No. 290—Galvanized..... per doz. \$3.25 3.90 4.50

GRAPPLING IRONS

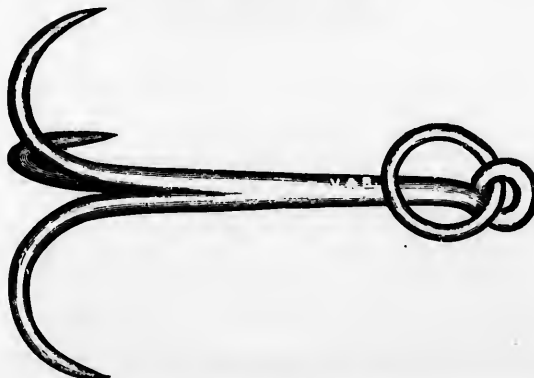

WROUGHT IRON, PAINTED

Nos.....	1	2	3	4	5
Size of Iron.....	½	¾	1	1½	2 inch.
Each.....	\$0.50	0.75	1.00	1.50	2.00

IRON STOCK ANCHORS

TESTED



Weights	25	30 to 50	60 to 75	100 lbs. and larger
Price	per lb. \$0.10	0.08	0.07	0.06

GALVANIZED STOCK ANCHORS

Weights	8 and 10 lbs.	12 to 18 lbs.	20 to 30 lbs.
Price	per lb. \$0.14	0.12	0.10

DIRIGO FOLDING ANCHORS

GALVANIZED



OPEN

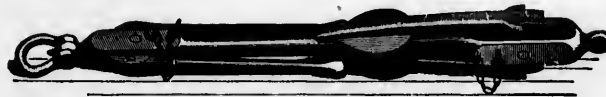

CLOSED

Size	4	6	10	16	20	26	30 lbs.
Price	each \$1.90	2.25	3.75	5.25	6.75	7.80	9.00

867

..... per doz. \$4.85
 " 0.50

¾ ¾ inch.
 3.80 4.50

4 5
 1 1 inch.
 1.50 2.00

CHAIN



CLOSE LINK COIL CHAIN

Size	$\frac{1}{8}$	$\frac{5}{32}$	$\frac{3}{16}$	$\frac{7}{32}$	$\frac{1}{4}$	$\frac{9}{32}$	$\frac{5}{16}$	$\frac{3}{8}$	inch.
Per 100 lbs.....	\$.....								

PROOF CABLE CHAIN

Size	$\frac{7}{16}$	$\frac{1}{2}$	$\frac{9}{16}$	$\frac{5}{8}$	$\frac{3}{4}$	$\frac{7}{8}$	1	1 $\frac{1}{8}$	1 $\frac{1}{4}$	1 $\frac{1}{2}$	inch.
Per 100 lbs	\$.....										

B. B. CRANE CHAIN

Size.....	$\frac{3}{8}$	$\frac{7}{16}$	$\frac{1}{2}$	$\frac{9}{16}$	$\frac{5}{8}$	$\frac{3}{4}$	$\frac{7}{8}$	inch.
Per 100 lbs	\$.....							

ENGLISH COIL CHAIN

Weight of 100 feet and Proof Strain.

Size	$\frac{1}{8}$	$\frac{5}{32}$	$\frac{3}{16}$	$\frac{7}{32}$	$\frac{1}{4}$	$\frac{5}{16}$	$\frac{3}{8}$	$\frac{7}{16}$	$\frac{1}{2}$	$\frac{9}{16}$	$\frac{5}{8}$	$\frac{3}{4}$	$\frac{7}{8}$	1	1 $\frac{1}{8}$	1 $\frac{1}{4}$	in.diam.
Weighs.....	30	38	44	48	52	98	148	198	260	315	413	500	700	950	1200	1500	lbs.
Proof Strain	$\frac{3}{4}$																
						1 $\frac{1}{2}$	2 $\frac{1}{2}$	3 $\frac{1}{2}$	4 $\frac{1}{2}$	6	9	13	17	21	27	tons.	

AMERICAN B. B. CRANE CHAIN

Weight of 100 feet and Proof Strain.

Size	$\frac{3}{16}$	$\frac{1}{4}$	$\frac{5}{16}$	$\frac{3}{8}$	$\frac{7}{16}$	$\frac{1}{2}$	$\frac{9}{16}$	$\frac{5}{8}$	$\frac{3}{4}$	$\frac{7}{8}$	1	1 $\frac{1}{8}$	1 $\frac{1}{4}$	1 $\frac{1}{2}$	in. diam.
Weighs	47	75	100	150	200	250	325	410	550	750	1000	1250	1500	2200	lbs.
Proof Test.....	1000	1500	3000	3800	5650	8000	10000	12000	16000	20000	30120	36150	47000	72000	"
Tensile "	2000	3000	5000	7500	9000	11500	16000	19000	29000	40000	50000	66000	80000	116000	"

NOTE—Chain is, unless otherwise ordered, $\frac{1}{16}$ in. over or larger than diameter given.

REPAIRING LINKS



No. 351

Wrought, Open for Welding.

Size.....	$\frac{3}{16} \times 1\frac{1}{4}$	$\frac{1}{4} \times 2$	$\frac{5}{16} \times 2\frac{1}{4}$	$\frac{3}{8} \times 2\frac{1}{2}$
Per gross.....	\$1.05	2.15	2.65	3.00



No. 350

Lloyd's, Japanned for Riveting.

Size.....	$\frac{3}{16}$	$\frac{1}{4}$	$\frac{5}{16}$	$\frac{3}{8}$	$\frac{7}{16}$	$\frac{1}{2}$	$\frac{5}{8}$	$\frac{3}{4}$
Per dozen..	\$0.40	0.40	0.45	0.55	0.65	0.85	1.25	2.30

WIRE ROPE



ROUND WIRE ROPES

GALVANIZED WIRE ROPE

FOR SHIPS' RIGGING, DERRICK STAYS, ETC.

6 Strands, 7 Wires to the Strand; Hemp Centre.

Diameter.....	¼	⅝	¾	⅞	Circumference..	1½	1¾	2	2¼	2½	2¾	3	3¼ inch.
100 ft. weighs about....	8	14½	19	29		34	42	59	75	92	113	133	158 lbs.
Price per lb.	\$0.20	0.17	0.16½	0.16		0.15	0.13	0.12	0.11	0.10½	0.10	0.10	0.09½
Galvanized Seizing Wire, in 1000 feet coils.....	per lb. \$.....												

STEEL WIRE ROPE

BEST CRUCIBLE CAST STEEL, FOR HOISTING, TRANSMISSION OF POWER, ETC.

No. 2

SPECIALLY FLEXIBLE

For Cranes, Derricks, Etc.

6 Strands, 24 Wires to the Strand; Hemp Centres.

No. 3

FLEXIBLE

For Elevators and Hoists

6 Strands, 19 Wires to the Strand; Hemp Centre.

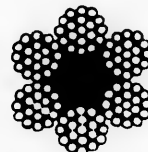
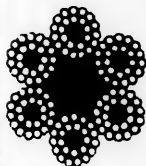

SECTION OF No. 2

SECTION OF No. 3

Diameter.....	¼	⅝	¾	⅞	1½	1¾	2	2¼	2½	2¾	3	3¼ inch.
No. 2.....	per foot	0.13	0.15	0.18	0.23
" 3.....	"	\$0.07	0.09½	0.10	0.11	0.12	0.16	0.18	0.23	0.26	0.33	

Approximate Weight and Strength of Crucible Cast Steel Wire Hoisting Ropes

Diameter.....	¼	⅝	¾	⅞	1½	1¾	2	2¼	2½	2¾	3	3¼ inch.
Circumference.....	1	1½	1¾	2	2½	2¾	3	3½	4	4½	4¾	5 inch.
No. 2—Weight per 100 feet.....	17	21	29	39½	58	83	108	145	175	233	333	lbs.
" 3— " ".....	17	23	27	42	70	94	125	160	204	260	366	"
" 2—Breaking Strain, Tons (2240 lbs.)..	2½	4	6	7½	12	16½	22½	28	36	47	60	Tons.
" 3— " " " ".....	4½	6	7½	10½	17	24	32½	41	53	60	94	"
Minimum Size of Sheave for No. 2.....	2	2	2	3	6	8	10	15	18	22	30	inch.
" " " " " ".....	3	3	4	6	8	12	16	21	24	33	43	"

Take one-seventh of Breaking Strain for Safe Working Load.

Approximate Weight and Strength of Manilla Rope.

Diameter.....	¾	1	1½	1¾	2	2½	2¾	3	3½	4	4½	4¾	5 inch.
Circumference.....	1	1½	2	2½	3	3½	4	4½	5	5½	6	6½	7 inch.
Strength in lbs. (new)	400	450	750	900	1250	1700	2250	3000	4000	5000	5800	7000	8000
Number of feet in a lb	70	42	34	24	17	12	10	7½	6	5	4½	3½	3
Diameter.....	1½	1¾	2	2½	2¾	3	3½	4	4½	4¾	5	5½	6 inch.
Circumference.....	3½	3¾	4	4½	4¾	5	5½	6	6½	7	7½	8	9
Strength in lbs. (new)	8200	11000	12000	13500	17000	19000	27000	20000	31500	37000	42000	48000	60000
Number of feet in a lb	2½	2	1½	1¼	1¼	1¼	1	0.90	0.68	0.55	0.48	0.42	0.34

¾ to 1½ inch, 100 fathoms in a coil; 1½ to 3 inch, 120 fathoms.

ROPE

SISAL

Diameter $\frac{7}{8}$ inch and larger	Basis	\$....	per lb.
" " " "	Advance	$\frac{1}{2}$ cent	"
" $\frac{3}{4}$ and $\frac{5}{8}$ inch	"	1 "	"
" $\frac{1}{2}$ inch	"	1 $\frac{1}{2}$ "	"
Uncoiled	"	$\frac{1}{2}$ "	"

MANILLA

Diameter $\frac{7}{8}$ inch and larger	Basis	\$....	per lb.
" " " "	Advance	$\frac{1}{2}$ cent	"
" $\frac{3}{4}$ and $\frac{5}{8}$ inch	"	1 "	"
" $\frac{1}{2}$ inch	"	1 $\frac{1}{2}$ "	"
Bolt and Point Rope	"	1 $\frac{1}{2}$ "	"
Tallow Laid Transmission Rope	"	2 "	"
Tarred Rope	Less	$\frac{1}{2}$ "	"



For approximate weight and strength of Manilla Rope, see page 309.

COTTON

Diameter	$\frac{1}{8}$	$\frac{3}{16}$	$\frac{1}{4}$	$\frac{5}{16}$	$\frac{3}{8}$	$\frac{7}{16}$	$\frac{1}{2}$	$\frac{5}{8}$	$\frac{3}{4}$ inch.
Feet to the lb.	125	90	65	37	25	19	14	10	7
In Coils, about	25	25	25	25	35	35	40	40	40 lbs.
Per lb.	\$....

CORDAGE

Russia Sea Line	per lb.	\$....	Tarred Russia Hemp Rope	per lb.	\$....
" Halyard	"	" " Hambroline	"
Dry Tarred Lath Yarn	"	" " House Line	"
Sisal Hay, Hide and Cheese Rope	"	" " Marline	"
Manilla Marline	"	" " Spun Yarn	"

CLOTHES LINES



COTTON CLOTHES LINES

Length	48	50	60	72	75	80	100 feet.
Cable	per doz.	\$1.30	1.05	2.00	2.15
Braided	"	2.00	3.00 4.00

GALVANIZED CLOTHES LINE WIRE



In coils of 50 or 100 feet.

Nos.	16	17	18	19	
7 Strands	per 1000 feet	\$9.50	6.50	5.00	4.00
6 " Hollow	"	6.20	4.60	3.70

BED CORDS

Length	48	60	72	100 feet.
Sisal, 3 Threads	per doz.	\$....
" 6 "	"
Cotton	"

AWNING AND CHALK LINES



No. 5
 " 4½
 " 4
 " 3½

BRAIDED COTTON AWNING LINES

White or Drab.

Nos.....	3½	4	4½	5	
Length.....	48	48	48	100	feet.
Per doz. hanks.....	\$2.25	3.00	3.75	11.25	



No. 3
 " 2
 " 1
 " 0

COTTON CHALK LINES

20 foot Hanks, 12 Hanks in a bundle, 6 connected.

Nos.....	0	1	2	3	
Silver Lake Braided..	per gross	\$9.00	9.75	10.50	11.25
Nos.....	12	15	18	24	30
Cotton Chalk Lines....	per gross	\$1.85	2.30	2.75	3.40 3.85

GARDEN LINES

No. 1—Cotton.....	per doz.	\$....
" 2— ".....	"
" 3—Hemp.....	"

MASONS' LINES

No. 15—Cotton, 100 ft. Hanks.....	per doz.	\$....
" 18— " 100 ft.	"
" 28—Hemp, 100 ft. ".....	"

One dozen in a box.

TWINE



Cotton Twine, 2-ply, in ½ lb. balls in 5 lb. bags.....	per lb.	\$0.22
" " 4-ply, " " " " " ".....	"	0.30
" Bag Twine, in ½ lb. balls, 12 balls in a package.....	per package	0.90
No. 1—Magenta Counter Twine, in ½ lb. balls, 12 balls in a package.....	"	1.20
" 12—Flax Stitching Twine " " " " " ".....	"	2.38
" 15— " Mattress " " " " " ".....	"	2.38
" 20— " Tufting " " " " " ".....	"	1.50
" 50— " " " " " ".....	"	1.80
" 126—Indian Hemp Wrapping Twine " " " " " ".....	"	0.78
" 100—Jute Counter " " " " " ".....	"	0.84
" 108—Light Unfinished Jute Wrapping Twine, in ½ lb. balls, 12 balls in a package.....	"	0.72
" 112— " " " " " ".....	"	0.60
" 135—Jute Sewing Twine " " " " " ".....	"	0.60
" 254—Russia Hemp Bag Twine, 2-ply " " " " " ".....	"	0.78
" 254— " " 3-ply " " " " " ".....	"	0.78
" 644—Bleached Flax " " " " " ".....	"	0.98
" 256—Russia Hemp Heavy Parcel Twine in 2 lb. balls.....	per lb.	0.28
" 115—Jute Seaming Cord in 2 lb. balls.....	"	0.19
Flax Sewing or Sail Twine, 6, 8, or 10-ply, in hanks about 1 lb.....	"	0.37

BARBOUR'S STANDARD SHOE THREAD

Nos.....	8	9	10	12	15	20	25
Barbour's Standard.....	per box	\$0.78	0.86	0.87	0.92	1.02	1.08
" "Harp" Brand.....	"	0.68	0.72	0.78	0.83	0.95	1.00

8 balls in a box, 3 boxes in a parcel.

COTTON SEINE TWINE

Soft Laid Seine or Hammock Twine, 9, 12, 16, 20, 24, 28, 36, 40 and 48 thread.....	per lb.	\$0.35
Hard Laid " " " 9, 12, 16, 20, 24, 28, 36, 40 and 48 thread.....	"	0.35

ST. PETER'S RUSSIA HEMP COD LINES

Threads.....	6	9	12	15	18	21	24
150 feet Hard Laid.....	per doz.	\$2.45	3.25	3.80	4.25	5.00	5.85

TENTS

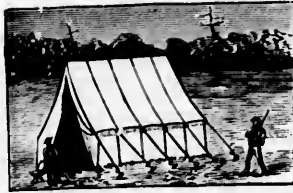

WALL TENTS



"A" OR WEDGE TENTS

WALL TENTS					"A" OR WEDGE TENTS			
Length and Width.	Height of Pole.	Height of Wall.	PRICE Without Poles or Stakes.		Length and Width.	Height.	PRICE Without Poles or Stakes.	
			8-oz. DUCK	10-oz. DUCK			8-oz. DUCK	10-oz. DUCK
7 x 7 feet	7 feet	2 feet	\$ 8.75	\$10.00	7 x 7 feet	7 feet	\$ 7.80	\$ 8.75
7 x 9 1/2 "	7 "	2 "	9.75	11.00	7 x 9 "	7 "	8.75	9.80
8 x 10 "	7 1/2 "	2 "	11.75	13.40	8 x 9 "	8 "	11.40	12.80
9 x 12 "	7 1/2 "	2 "	13.75	15.65	9 x 12 "	8 "	13.00	15.00
10 x 12 "	8 "	2 1/2 "	16.55	18.75	9 x 14 "	8 "	15.00	18.00
10 x 14 "	8 "	2 1/2 "	18.00	20.50				

COTTON DUCK

Nos	Ounces per square yard	per yard	6	8	10	12
22 inch wide			21 1/2	18	14 1/2	11 1/2
28 "			\$0.25	0.23	0.20	0.18
30 "			0.29	0.27	0.23	0.20
32 "			0.31	0.28	0.24	0.20
36 "			0.33	0.30	0.26	0.21
40 "			0.38	0.34	0.29	0.24
48 "			0.42	0.38	0.32	0.26
60 "			0.50	0.45	0.38	0.32
72 "			0.62	0.57	0.48	0.40
			0.75	0.68	0.57	0.47

Other widths and numbers can be supplied on short notice.

LIFE BUOYS



LIFE PRESERVERS



No. 1—Small Yacht size.....each	\$4.50	No. 4—Cork Life Preservers.....each	\$1.50
" 2—Life Buoys....."	5.00		

WOOLSEY'S COPPER BEST PAINT

The Best Covering now in use for Bottoms of Wooden Vessels.

In gallon tins.....	per gallon	\$3.60
---------------------	------------	--------

CHALK

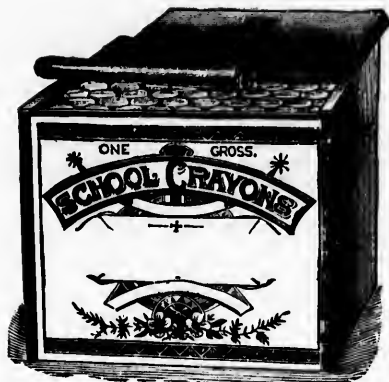

SCHOOL CRAYONS



CARPENTERS' CHALK

White, per gross.....	\$0.13½	Per gross.....	WHITE \$0.80	RED 0.95	BLUE 1.10
Lump Chalk, White.....					per 100 lbs. \$3.00

LUMBER PENCILS



No. 361—Dixon's, Black Lead, Hexagon, 4½ x ½ inch, Japanned.....		per gross	\$10.20
" 520— " Red " " 4½ x ½ " Paper Covered.....		"	16.00
" 521— " Blue " " 4½ x ½ " " ".....		"	16.00
" —Ross', Black " " 4½ x ½ " Japanned.....		"	9.35
" 232—Boker's, Black " " 4½ x ½ " " ".....		"	5.10
" 235— " Blue " " 4½ x ½ " " ".....		"	5.30
" 238— " Red " " 4½ x ½ " " ".....		"	5.10
" 7022— " Blue " Round, 5 x 1 " " ".....		"	16.15

One dozen in a box.

PENCIL HOLDERS



Adapted to Lumber Pencils of standard makes.

Pencil Holders only, Nickel-Plated, without handle.....	per doz.	\$15.00
---	----------	---------

METAL WORKERS' CRAYONS



No. 524—Sawed out of solid soapstone, flat shape, chisel point. Packed in ¼ gross boxes.....	per gross	\$6.25
--	-----------	--------

LEAD PENCILS

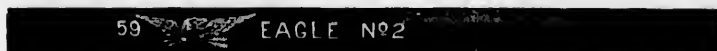

No. 59—Eagle, Plain Round, Cedar, Natural, No. 2.....	per gross	\$1.35
" 200—Faber " " " " " 2.....	"	1.20
" E—Eagle " " " " "	"	0.75
" 1000—Faber " " " " "	"	0.75

One gross in a box.

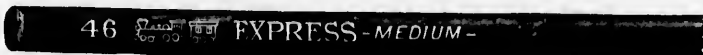

No. 46—Eagle, Black Medium, Round, with Gilt Stamp.....	per gross	2.20
" 52— " Natural " " " "	"	2.20
" 2300—Faber " " " " "	"	1.00
" 2402— " Black " " " "	"	2.00

One gross in a box.



No. 142—Eagle Hexagon, Silk Finish, Stained Wood, No. 2.....	per gross	4.15
" 143— " " " " " 3.....	"	4.15
" 101— " Round " " " " 1.....	"	3.50
" 102— " " " " " 2.....	"	3.50
" 121— " " Rosewood " " " 1.....	"	3.50

Half gross in a box.



No. 140—Eagle, Round, Cedar, Highly Polished, No. 2, with Patent Inserted Rubber Head.....	per gross	1.50
--	-----------	------



No. 222½ — Eagle, Round, Finest Finish, Gold Stamp, Specially Graded, No. 2½.....	per gross	4.75
" 223 — " " " " " " Hard and Firm, " 3.....	"	4.75
" 224 — " " " " " " Extra Hard, " 4.....	"	4.75
" 480H — Faber " " " Silver, Specially Graded,	"	4.00
" 480HH — " " " " " Hard and Firm,	"	4.00
" 480HHHH — " " " " " Extra Hard,	"	4.00

Nos. 222½ to 224, one dozen in patent packing boxes. Nos. 480, ¼ gross in a box.

GLASS CUTTERS



No. 3—Combined Glass Cutter and Putty Knife.....per doz. \$0.85



No. 4—Combined Glass Cutter and Putty Knifeper doz. 0.85

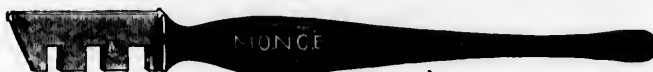

No. 7—Glass Cutter, Iron Handle.....per doz. 0.85

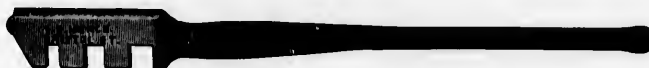

No. 1—Glass Cutter, with Hardened Steel Pin.....per doz. 1.75



No. XXX—Glass Cutter, Rosewood Handleper doz. 1.85
 " XX — " " Iron Handle (similar to No. 1)..... " 1.55

One dozen in a box.

GLAZIERS' DIAMONDS

SHARRATT & NEWTH



Nos.	1	2	3	4
Crown Diamond, Plain.....	each	\$5.25	6.40	8.00
" " with Rack	"	5.05	7.20	8.80
New Patent, with Rack	"	5.00	6.80	8.00	10.00

These Diamonds are capable of being reset at small cost. Are Not Returnable except for resetting.

WINDOW GLASS

NUMBER OF PANES IN A BOX AND LIST PRICE PER PANE

SIZE.	NO. OF PANES.		PRICE PER PANE.		SIZE.	# Panels per 100 ft.	PRICE PER PANE.		SIZE.	# Panels per 100 ft.	PRICE PER PANE.		SIZE.	# Panels per 100 ft.	PRICE PER PANE.	
	soft	100ft	Star.	Double Diamond Star.			Star.	Double Diamond Star.			Star.	Double Diamond Star.			Star.	Double Diamond Star.
7 x 9	115	220	\$0.03	\$0.04	10 x 50	18	\$0.47	\$0.70	20 x 34	10	\$0.40	\$0.73	36 x 52	8	\$1.58	\$2.30
8 x 10	100	180	0.04	0.05	11 x 51	17	0.65	0.74	38 1/2 x 15	10	0.60	0.80	54 1/2 x 7	7	1.80	2.70
9 x 12	87	135	0.04	0.05	12 x 52	16	0.72	0.78	40 1/2 x 14	9	0.60	0.80	60 1/2 x 7	6		3.37
10 x 12	80	120	0.05	0.07	14 x 54	14	0.78	0.83	44 1/2 x 13	8	0.65	0.94	66 1/2 x 7	5		3.90
	72	108	0.06	0.08	16 x 56	12	0.85	0.89	48 1/2 x 12	7	0.78	1.15	72 1/2 x 6	4		4.47
	66	99	0.07	0.09	18 x 58	10	0.92	0.96	52 1/2 x 11	6	0.85	1.28	78 1/2 x 5	3		5.33
	60	90	0.08	0.11	20 x 60	9	1.00	1.04	56 1/2 x 10	5	1.10	1.50	84 1/2 x 4	2		6.50
	54	81	0.09	0.12	22 x 62	8	1.08	1.12	58 1/2 x 9	4	1.15	1.57	86 1/2 x 3	1		7.80
	48	72	0.10	0.13	24 x 64	7	1.16	1.20	60 1/2 x 8	3	1.22	1.82	74 1/2 x 5	1		9.40
	42	63	0.11	0.14	26 x 66	6	1.25	1.29	62 1/2 x 7	2	1.30	2.08	76 1/2 x 5	1		11.20
	36	54	0.12	0.15	28 x 68	5	1.35	1.39	64 1/2 x 6	1	1.40	2.08	78 1/2 x 5	1		13.00
	30	45	0.13	0.16	30 x 70	4	1.45	1.49	66 1/2 x 5	1	1.50	2.45	80 1/2 x 4	1		14.80
12 x 16	38	57	0.09	0.11	32 x 72	3	1.55	1.59	68 1/2 x 4	1	1.60	2.90	82 1/2 x 3	1		16.60
18 x 24	25	38	0.12	0.15	34 x 74	2	1.65	1.69	70 1/2 x 3	1	1.70	3.90	84 1/2 x 2	1		18.40
20 x 30	20	30	0.15	0.18	36 x 76	1	1.75	1.79	72 1/2 x 2	1	1.80	5.00	86 1/2 x 1	1		20.20
22 x 33	18	27	0.16	0.19	38 x 78	1	1.85	1.89	74 1/2 x 1	1	1.90					22.00
24 x 36	15	23	0.18	0.21	40 x 80	1	1.95	1.99	76 1/2 x 1	1	2.00					23.80
26 x 39	12	18	0.20	0.23	42 x 82	1	2.05	2.09	78 1/2 x 1	1	2.10					25.60
28 x 42	10	15	0.22	0.25	44 x 84	1	2.15	2.19	80 1/2 x 1	1	2.20					27.40
30 x 45	8	12	0.24	0.27	46 x 86	1	2.25	2.29	82 1/2 x 1	1	2.30					29.20
32 x 48	6	9	0.26	0.29	48 x 88	1	2.35	2.39	84 1/2 x 1	1	2.40					31.00
34 x 51	5	7	0.28	0.31	50 x 90	1	2.45	2.49	86 1/2 x 1	1	2.50					32.80
36 x 54	4	6	0.30	0.33	52 x 92	1	2.55	2.59	88 1/2 x 1	1	2.60					34.60
38 x 57	3	5	0.32	0.35	54 x 94	1	2.65	2.69	90 1/2 x 1	1	2.70					36.40
40 x 60	2	3	0.34	0.37	56 x 96	1	2.75	2.79	92 1/2 x 1	1	2.80					38.20
42 x 63	1	2	0.36	0.39	58 x 98	1	2.85	2.89	94 1/2 x 1	1	2.90					40.00
44 x 66	1	2	0.38	0.41	60 x 100	1	2.95	2.99	96 1/2 x 1	1	3.00					41.80
46 x 69	1	2	0.40	0.43	62 x 102	1	3.05	3.09	98 1/2 x 1	1	3.10					43.60
48 x 72	1	2	0.42	0.45	64 x 104	1	3.15	3.19	100 1/2 x 1	1	3.20					45.40
50 x 75	1	2	0.44	0.47	66 x 106	1	3.25	3.29	102 1/2 x 1	1	3.30					47.20
52 x 78	1	2	0.46	0.49	68 x 108	1	3.35	3.39	104 1/2 x 1	1	3.40					49.00
54 x 81	1	2	0.48	0.51	70 x 110	1	3.45	3.49	106 1/2 x 1	1	3.50					50.80
56 x 84	1	2	0.50	0.53	72 x 112	1	3.55	3.59	108 1/2 x 1	1	3.60					52.60
58 x 87	1	2	0.52	0.55	74 x 114	1	3.65	3.69	110 1/2 x 1	1	3.70					54.40
60 x 90	1	2	0.54	0.57	76 x 116	1	3.75	3.79	112 1/2 x 1	1	3.80					56.20
62 x 93	1	2	0.56	0.59	78 x 118	1	3.85	3.89	114 1/2 x 1	1	3.90					58.00
64 x 96	1	2	0.58	0.61	80 x 120	1	3.95	3.99	116 1/2 x 1	1	4.00					59.80
66 x 99	1	2	0.60	0.63	82 x 122	1	4.05	4.09	118 1/2 x 1	1	4.10					61.60
68 x 102	1	2	0.62	0.65	84 x 124	1	4.15	4.19	120 1/2 x 1	1	4.20					63.40
70 x 105	1	2	0.64	0.67	86 x 126	1	4.25	4.29	122 1/2 x 1	1	4.30					65.20
72 x 108	1	2	0.66	0.69	88 x 128	1	4.35	4.39	124 1/2 x 1	1	4.40					67.00
74 x 111	1	2	0.68	0.71	90 x 130	1	4.45	4.49	126 1/2 x 1	1	4.50					68.80
76 x 114	1	2	0.70	0.73	92 x 132	1	4.55	4.59	128 1/2 x 1	1	4.60					70.60
78 x 117	1	2	0.72	0.75	94 x 134	1	4.65	4.69	130 1/2 x 1	1	4.70					72.40
80 x 120	1	2	0.74	0.77	96 x 136	1	4.75	4.79	132 1/2 x 1	1	4.80					74.20
82 x 123	1	2	0.76	0.79	98 x 138	1	4.85	4.89	134 1/2 x 1	1	4.90					76.00
84 x 126	1	2	0.78	0.81	100 x 140	1	4.95	4.99	136 1/2 x 1	1	5.00					77.80
86 x 129	1	2	0.80	0.83	102 x 142	1	5.05	5.09	138 1/2 x 1	1	5.10					79.60
88 x 132	1	2	0.82	0.85	104 x 144	1	5.15	5.19	140 1/2 x 1	1	5.20					81.40
90 x 135	1	2	0.84	0.87	106 x 146	1	5.25	5.29	142 1/2 x 1	1	5.30					83.20
92 x 138	1	2	0.86	0.89	108 x 148	1	5.35	5.39	144 1/2 x 1	1	5.40					85.00
94 x 141	1	2	0.88	0.91	110 x 150	1	5.45	5.49	146 1/2 x 1	1	5.50					86.80
96 x 144	1	2	0.90	0.93	112 x 152	1	5.55	5.59	148 1/2 x 1	1	5.60					88.60
98 x 147	1	2	0.92	0.95	114 x 154	1	5.65	5.69	150 1/2 x 1	1	5.70					90.40
100 x 150	1	2	0.94	0.97	116 x 156	1	5.75	5.79	152 1/2 x 1	1	5.80					92.20

WINDOW GLASS

Stocked in 50 feet boxes, from 16 to 40 united inches, and in 100 feet cases, from 16 to 70 united inches.

Sizes.....	16 to 25	26 to 40	41 to 50	51 to 60	61 to 70 inch.
Price 50 ft. boxes.....	\$.....
" 100 ft. cases.....

For number of panes in a box and list price per pane, see page 379.

PUTTY

Pure Bladder and Bulk Putty, made from best Grey's Chalk and Pure Linseed Oil.

In barrels.....	per lb. \$....
" bladders.....	".....
" tins, 12½ and 25 lbs. each.....	".....

Tins packed in cases containing 100 lbs.

WHITE LEAD

	PURE	EXTRA GEM	STANDARD	No. 1
Per 100 lbs.....	\$....

In 25 lb. irons.

DRY LEAD

Red Lead, Dry, in 100 lb. Kegs.....	per lb. \$....
White ".....	".....

LAMP BLACK

	ORDINARY		GERMANTOWN
¼ lb. packages.....	per lb. \$....		¼ lb. packages..... per lb. \$....
1 " ".....	".....		1 " "..... ".....

HARRIS' IMPROVED PAINT MILLS

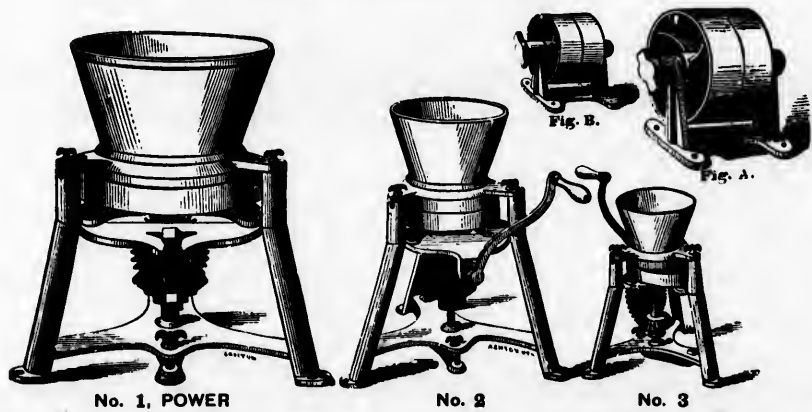

No. 1—Hand or Power Mill, Hopper 8 in. high, 14 in. across top, holds 3 gallons, weight 118 lbs.....	each	\$28.00
" 2—Hand Mill " 6 " " 8 " " " 1 " " 30 ".....	".....	10.00
" 3— " " 5 " " 7 " " " " 21 ".....	".....	5.00
" 4— " " 4 " " 5 " " " " 15 ".....	".....	7.00
" A—Pulley for No. 1 Power Mill, Pulley 12 in. diameter, 5 in. face, weight 84 lbs.....	".....	15.00
" B— " suitable for driving the No. 2 Mill.....	".....	8.00

The No. 1 requires about ¼ horse power and has a capacity of about 300 lbs. per day. The pulley should make revolutions per minute, No. 2 about 50 revolutions per minute. No. 1 is supplied with extra handle for about 100 hand use.

BUILDING PAPER



In rolls of 400 square feet

No. 20—Dry Building Paper or Straw Board, for lining buildings.....	per roll	\$0.56
" 21—Dry Fibre Building Paper, No. 2 " "	"	0.60
" 22—Ideal, Dry Fibre Building Paper, " "	"	1.10
" 23—O.K. No. 1, Building Paper (corded) " "	"	1.25
" 24—O.K. No. 2, " " " "	"	1.20
" 25—Blue, Rosin Sized, No. 1 Building Paper, " "	"	0.85
" 26—Blue, Rosin Sized, No. 2, " "	"	0.70
" 27—Tarred Straw Board " " " (not suitable for roofing).....	"	0.70
" 28—Tarred Fibre, No. 1 " " " " " "	"	1.00
" 29—Tarred Fibre, No. 2 " " " " " "	"	0.75

No. 30—Best Tarred Pure Wool Felt, for roofing, in 50 to 60 lb. rolls.....per 100 lbs. \$2.70

CERITE WATERPROOF SHEATHING

No. 31—Cerite Waterproof Sheathing, in rolls 20 inches wide, 800 square feet each.....per roll \$2.00

The waterproof composition is forced through the paper, filling up the pores, forming a coating on each side, making it perfectly Wind-proof and Water-proof. It is specially adapted for use under metal roofing and siding, there being no injurious chemicals used.

ASBESTOS BUILDING FELT

36 inches wide, about 8 lb. to the 100 square feet.

No. 32—Asbestos Building Felt, in rolls about 85 lbs.....per lb. \$0.10

For fire-proof construction several thicknesses should be used; can be used also for covering furnace pipes, fire-heated surfaces, etc.

CARPET FELT

"Gore Brand" Moth Proof Elastic Carpet Felt, 16 oz.per 100 lbs. \$3.75

COAL TAR AND PITCH

Refined Coal Tar in barrels, 40 gals.....	per barrel	\$8.00
Pure Coal Tar " 40 "	"	7.00
XXX Refined Coal Tar in quart tins.....	per doz.	1.80
Roofing Pitch, made from pure Coal Tar, 275 lbs.....	per barrel	4.50
Pine Pitch.....	"	6.00

PINE TAR

In patent pint packages.....per doz. 1.30

ROSIN

Amber Rosin, G quality.....per 100 lbs. ...

BEESWAX

Virgin, Pure, In cakes.....per lb.

ROLL PAPER CUTTERS



Single or in combination.

Sizes.....	12	15	18	20	24	30	inch.
For Single Cutter.....	\$2.25	2.25	2.25	2.25	3.00	3.75	each.

Combination Cutters can be supplied, combining any of the above sizes, at prices given.

ROLL PAPER

Diameter of Rolls, 8 inches.

BROWN

Widths of Rolls.....	12	15	18	20	24	30	inch.	
No. 1—Brown, basis of weight, 24 x 36 inches, 100 lbs.....							price per lb.	\$.....
“ 2—.....							price per lb.	“.....

MANILLA

Widths of Rolls.....	12	15	18	20	24	30	inch.	
Best Manilla, basis of weight, 24 x 36 inches, 45 lbs.....							price per lb.	\$.....
“.....							price per lb.	“.....

WRAPPING PAPERS

No 1, BROWN

Sizes.....	18 x 24	22 x 32	24 x 36	30 x 40	34 x 48	40 x 50	44 x 60
Weights.....	30	60	80	100	150	200	300 lbs.
Price.....	per lb. \$.....						

No. 2, BROWN

Sizes.....	18 x 24	22 x 32	24 x 36	30 x 40	34 x 48	44 x 60
Weights.....	40	60	80	100	150	300 lbs.
Price.....	per lb. \$.....					

BUTCHERS' BROWN

Sizes.....	18 x 24	22 x 32	24 x 36	30 x 40	40 x 50	44 x 60
Weights.....	30	60	80	100	200	300 lbs.
Price.....	per lb. \$.....					

BEST MANILLA

Sizes.....	18 x 24	20 x 30	24 x 36	30 x 40	32 x 48	40 x 50
Weights.....	30	40	60	80	120	200 lbs.
Price.....	per lb. \$.....					

SQUARE BOTTOM MANILLA BAGS

Sizes.....	1/4	1/2	1	2	3	4	5	6	8	10	12	14	16	20	25	lbs.
Light.....per 1000	\$0.75	0.90	1.10	1.50	1.90	2.30	2.70	4.10	4.50	5.50	6.50	7.00	8.00	9.00		
Heavy.....	1.00	1.20	1.40	1.80	2.20	2.60	3.10	3.60	4.70	5.70	7.00	8.00	9.00	10.00	11.00	

EXTRA HEAVY MANILLA BAGS

Hand made, tight and strong—for wrapping powder, Paris green, dry colors, etc.

1/2, 1 and 2 lb. bags.....	per lb.	\$.....
5, 8, 12 and 20 lb. “.....	“	“.....

SHOT BAGS

1 lb. bags.....	per 100 bags
3 “.....	“	“.....

FOLDING NAIL BOXES

Strawboard.

Sizes, 3, 5, 7 and 10 lbs.....	per lb.
--------------------------------	---------	-------

PAIN T BRUSHES

ROUND OR OVAL



NOT BRIDLED



BRIDLED

- No. 1—Round, Ground, Grey Centre, White Outside, Bridled ready for use from No. 1-0 up without extra charge.
- " 2—Oval or Round, Extra Ground, Grey Centre, all Bristles, Bridled ready for use, from No. 1-0 up without extra charge.
- " 3—Oval, Extra, all White, Bridled ready for use from No. 1-0 up without extra charge.
- " 4—Oval or Round, Super, all White Bristles, Bridled ready for use from No. 1-0 up without extra charge.

Size Nos.	7	8	5	4	3	2	1	1-0	2-0	3-0	4-0	5-0	6-0	7-0	8-0
No. 1.....per doz.	\$1.40	1.80	2.40	3.00	3.75	4.50	5.25	6.00	8.55	10.35	12.50	15.25	17.50	21.00	24.00
" 2....."	1.65	2.00	2.75	3.50	4.25	5.25	5.85	7.75	9.00	11.50	13.75	16.00	19.50	23.00	26.00
" 3....."	2.20	2.85	3.35	4.00	4.65	5.35	6.00	7.05	9.75	11.50	13.50	16.00	18.00	22.00	25.00
" 4....."	2.40	3.15	3.80	4.25	5.25	5.75	6.35	8.15	10.75	13.10	15.05	18.10	22.15	25.85	29.05



No. 9A, COLUMBIA OVAL CHISEL PAINT

Selected Black China Bristles. Bridled ready for use without extra charge.

Nos.	4-0	5-0	6-0	7-0	8-0	9-0
Per dozen.....	\$16.10	19.00	21.75	25.65	29.45	35.50

FLAT PAINT BRUSHES



No. 10—Ground, Grey Centre, White Outside.

- " 11—Acme, White Bristles.
- " 12—Extra Grey, all Grey Bristles, White Outside, Bridled from 3-0 up.
- " 13—Standard, all White Bristles, Metal Bound, Bridled from 3-0 up.

Size Nos.	2-0			3-0				4-0			5-0			
	3	3½	4	2½	3	3½	4	3	3½	4	3	3½	4	
Length of Hair .inches														
No. 10.....per doz.	\$			5.25	6.00	7.25	8.75							
" 11....."				3.50	5.00	6.65	8.00							
" 12....."		9.50	10.65		13.50	15.50	17.40	17.90	19.45	21.35	24.00	27.25	30.50	
" 13....."		10.65	12.00	13.35		14.50	16.60	18.65	17.85	20.25	22.65	19.85	22.60	25.65

PAINTERS' SASH TOOLS



ROUND SASH

Size Nos.	1	2	3	4	5	6	7	8	9	10
No. 26—Wire Bound, all White Bristles	\$0.65	0.85	1.05	1.35	1.65	2.00	2.35	2.55
" 27—Twine Bound, all Bristles	0.75	0.95	1.15	1.35	1.65	2.00	2.35	2.65	3.00	3.35



DOMED SASH



CHISELLED SASH

- No. 23A—Standard Flat Sash, Selected French Bristles, Metal Bound.
- " 30 —Standard Domed Sash, Selected French Bristles, Metal Bound.
- " 31 —Standard Chiselled Sash, Selected French Bristles, all White, Metal Bound.

Size Nos.	1	2	3	4	5	6	7	8	9	10	12
No. 28A	\$1.20	1.55	1.95	2.40	3.05	3.55	4.30	5.00	5.85	6.60
" 30	1.35	1.60	2.00	2.55	3.20	3.65	4.35	5.35	6.40	7.20
" 31	2.55	3.35	4.25	5.25	6.50	7.65	8.65	13.20

CHISELLED FLOWING BRUSHES



No. 39, SINGLE CHISELLED FLOWING

Size.....	1	1½	2	2½	3 inch.
No. 39.....	\$5.40	7.20	9.60	13.45	17.25

MOTTLERS



Nos. 92 and 93

VARNISH OR COPYING BRUSHES



No. 91

Size,	½	1	1½	2	2½	3	3½ inch.	
No. 92—Camel Hair Mottlers	\$2.90	3.20	5.20	7.50	11.20	14.40	18.00	
" 93—Bear " "	2.00	2.00	3.85	5.20	6.45	7.80	9.15	
No. 91B—Camel Hair, Varnish or Copying, A quality.....							per doz. inches	\$1.00
" 91C— " " " " B quality.....							" "	2.15

FLAT WALL PAINT BRUSHES



No. 18

All Bristles, Grey Centre, White Outside, Metal Bound, not Bridled.

Size Nos.....	5	4	3	2	1	1-0	2-0
Per dozen.....	\$5.95	6.65	8.00	9.35	12.00	13.35	14.65

VARNISH BRUSHES



OVAL

No. 23A—White, Chiselled Oval, Superior White French Bristles, Nickel Ferrules.
 “ 23B—Black, “ “ Selected Black China Bristles, specially prepared.

Size Nos.....	6	5	4	3	2	1	1-0	2-0	3-0
No. 23A..... per doz.	\$4.65	5.05	6.05	7.65	9.35	10.65	13.35	16.00	19.35
“ 23B..... “ “	3.65	4.35	5.00	6.00	7.35	8.00	9.35	11.35	13.35



FLAT

Size.....	1	1½	2	2½	3 inch.
No. 33—Thin Flat, all Bristles..... per doz.	\$1.00	1.40	2.15	2.85	3.65
“ 34—Medium Flat “	1.40	2.30	3.15	4.00	4.80
“ 35—Heavy Flat “	1.90	2.90	4.25	5.65	7.05
“ 36—Extra Heavy Flat, all Bristles	2.90	4.35	6.00	8.00	10.65
“ 37—Chiselled, all White Bristles	2.35	3.05	5.35	7.00	9.35
“ 38A—Electric, Chiselled, all Black Bristles	0.80	1.30	2.50	3.00	4.00
“ 38C —Chiselled, all Black China Bristles.....	2.35	3.65	5.35	7.00	9.35
“ 38DX — “ “ “ “	3.65	4.65	6.00	8.00	10.65
“ 38EXX — “ “ “ “	4.00	5.00	6.65	8.35	12.00
“ 38FXXX— “ “ “ “	4.65	6.00	8.00	10.65	14.65

PAINTERS' DUSTERS



Nos. 50 and 51

Varnished Handles.

Size		4	6	8	10 inch.
No. 50—Extra, Grey Centre, Black Casing, Wire Drawn.....	per doz.	\$6.00	9.00	11.65	13.35
" 51—Super, Mixed Grey Centres, White Casing, Wire Drawn	"	8.00	11.35	13.35	16.00

SEAMING OR CAULKING BRUSHES



No. 69

Drawn with Brass Wire.

Size		4½	6
Extra Mixed.....	per doz.	\$1.95	2.95
All Bristles.....		3.65	4.40

BRICK HEADERS OR TRENCHERS



No. 70

For striping brick walls.

Size		2	2½	3	3½	4
Per doz.....		\$2.15	2.20	2.25	2.35	3.00

GLUE OR PASTE BRUSHES

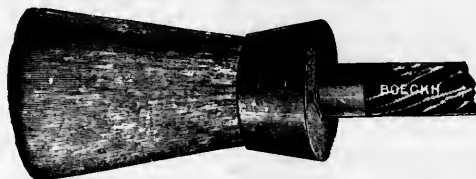

No. 72

All Grey Bristles, Wire or Iron Bound.

Nos.....	6	4	2	1-0	2-0	3-0	4-0	5-0	6-0
Per doz..	\$2.55	4.00	6.00	9.55	14.65	20.55	26.40	32.00	40.00

STENCIL BRUSHES



No. 74

All White French Bristles, Iron Ferrules.

Nos.....	00	0	1	2	3	4	5	6
Per doz ...	\$1.45	1.75	2.05	2.45	2.95	3.40	3.85	4.40
Nos.....	7	8	10	12	14	16	18	
Per doz.....	\$5.00	5.00	6.20	8.80	11.00	13.20	17.65	

MARKING BRUSHES



No. 121

Round or Flat.

Nos.....		1	2	3	4	5	6
Per gross.....		\$4.80	5.85	6.95	8.00	10.00	12.00
Nos. 1 to 6, assorted		per gross 7.20					

KALSOMINE BRUSHES

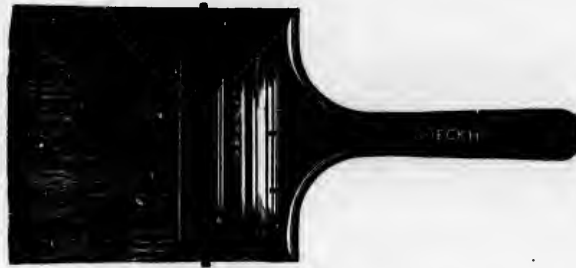

Size	6	7	8	9	inch.
No. 43 — Mixed White, Iron Bound, 3-0.....	per doz. \$ 8.00	9.35	10.65	12.00	
" 44A — " " Brass Bound, Special.....	21.35	23.65	28.00	
" 46 — All White, Brass Bound, Standard, 3-0.....	14.65	17.35	20.00	22.65	
" 46 — " " " 4-0.....	22.65	26.65	30.65	34.65	

No. 44, C. KALSOMINE

Extra White Mixed, Bristles Outside, Lacquered Ferrules, Varnished Handles.

Size Nos.....	1-0		2-0			3-0			4-0			6-0			
Width.....	7	8	6	7	8	6	7	8	6	7	8	6	7	8	inch.
No. 44..... per doz.	\$6.00	7.35	7.50	9.00	10.00	10.00	11.65	13.35	13.35	14.65	16.00	16.00	18.00	19.35	

No. 47, IMPERIAL O.K. KALSOMINE

All Selected White Russian Bristles throughout, Brass Ferrules.

Size Nos.....	5-0			6-0		8-0		10-0			
Width.....	6	7	8	7	8	7	8	7	8	9	inch.
No. 47..... per doz.	\$29.35	33.35	40.00	46.65	52.00	60.00	66.65	66.65	73.35	80.00	

WHITWASH BRUSHES AND HEADS



Nos. 47B and 48C

No. 49

Size Nos.....	1				1-0				
Width.....	6	7	8	9	6	7	8	9	inch.
No. 47B..... per doz.	\$2.00	2.35	2.65	3.50	2.75	3.25	3.75	4.25	

No. 48, CROWN WHITWASH BRUSHES

Extra Mixed Centre, White Outside, Leather Bound.

Size Nos.....	2-0			3-0			4-0			5-0			
Width.....	6	7	8	6	7	8	7	8	9	7	8	9	inch.
No. 48C..... per doz.	\$6.00	7.00	8.00	9.35	10.65	12.00	16.00	18.65	21.35	22.65	24.70	26.65	
" 49—Heads....	11.75	13.20	14.65	16.85	19.80	23.45	26.40	29.35	32.25	

SCRUBBING AND STOVE BRUSHES



No. 140

Shaped Pattern. Made with Patent Solid Back.

No. 60—Fibre, Double Wing.....	per doz.	\$ 3.00
" 61— " " " " " " " " " " " "	"	4.20
" 62— " " " " " " " " " " " "	"	5.00
" 70—Whisk " " " " " " " " " " " "	"	4.00
" 71— " " " " " " " " " " " "	"	4.75
" 72— " " " " " " " " " " " "	"	5.50
" 80—Super Whisk, Double Wing....	"	5.00
" 81— " " " " " " " " " " " "	"	6.00
" 82— " " " " " " " " " " " "	"	7.00
" 90—Monkey Bass " " " " " " " " " " " "	"	5.35
" 91— " " " " " " " " " " " "	"	6.65
" 92— " " " " " " " " " " " "	"	8.00
" 100—Extra Grey Mixed " " " " " " " " " " " "	"	6.55
" 101— " " " " " " " " " " " "	"	7.75
" 102— " " " " " " " " " " " "	"	8.95
" 111—Yellow OK " " " " " " " " " " " "	"	9.35
" 112— " " " " " " " " " " " "	"	11.35

No. 145, RUBBER OR DECK SCRUBS

Hardwood Handles included.

No. 10—Fibre.....	per doz.	\$ 9.00
" 20—Whisk.....	"	9.00
" 30—Grey Mixed.....	"	11.65
Extra Hardwood Handles.....	"	1.00



No. 152, BLACK LEAD DAUBERS

No. 0—Black Fibre.....	per doz.	\$ 0.80
" 1—White Centre.....	"	1.35
" 2—Grey Centre.....	"	1.75
" 3—All Black, Extra Quality.....	"	2.75



No. 149, STOVE BRUSH

Straight Pattern.

No. 30—Grey Centre, Double Wing.....	per doz.	\$3.00
" 31— " " " " " " " " " " " "	"	4.00
" 40—Black Mixed " " " " " " " " " " " "	"	4.50
" 41— " " " " " " " " " " " "	"	5.35

No. 150, STOVE BRUSHES

Pointed Pattern.

No. 70—Black Bristles, without Wings..	per doz.	\$ 6.35
" 71— " " " " " " " " " " " "	"	8.00
" 80—Extra Long Black " " " " " " " " " " " "	"	7.35
" 81— " " " " " " " " " " " "	"	9.65
" 90—Extra Black, Double Wings....	"	8.00
" 91— " " " " " " " " " " " "	"	10.00

SHOE BRUSHES AND DAUBERS



No. 155, TOP SHOE

Nos.....	00	0	20	21	16
Mixed..... per doz.	\$1.00	2.40	2.65	3.35	3.60
Nos.....	25	7			
Black Bristles..... per doz.	\$5.50	7.50			

No. 158, DAUBERS

Royal.....	per doz.	\$ 6.00
People's.....	"	3.25
No. 157—With Wood Handle—		
No. 1, Black Mixed.....	"	2.00
" 2, " Extra.....	"	2.65

HOUSEHOLD BRUSHES



No. 172, CORNICIE DUSTERS

Nos.....	1	2	3	4	5
Per doz.....	\$13.35	18.05	24.00	29.35	40.00



No. 177, FEATHER DUSTERS

Standard Turkey.
Bell-shape, full length.

Nos.....	10	12	14	16	18
Per doz.....	\$5.00	6.75	9.00	11.00	12.50

WINDOW BRUSHES AND CLEANERS



No. 164

No.	0 —Grey Centre	per doz.	\$6.20
"	1 — " "	"	8.05
"	2 — " "	"	10.25
"	3 — " "	"	12.45
"	4 — " "	"	14.65
"	5 — " "	"	23.45
"	101 —White Fibre	"	6.65
"	102 — " "	"	9.35
"	103 — " "	"	12.00
"	10 —Grey Mixed, Oval	"	5.35
"	11 — " "	"	6.65
"	20 —All Black Hair	"	10.65
"	21 — " "	"	13.35



No. 165

Single Rubber Cleaner	per doz.	\$5.00
Double " " 9 in.....	"	6.00
" " " 12 ".....	"	8.00



No. 165

Double Rubber Cleaner, 15 in.....	per doz.	\$11.20
Combination Brush and Rubber	"	10.00

PLATE POLISHING BRUSHES



Small Straight Pattern.

No.	10 —3 Row, White Fibre	per doz.	\$2.95
"	11 —4 " "	"	3.25
"	12 —5 " "	"	4.00
"	13 —6 " "	"	4.40
"	30 —3 " All Bristles	"	3.65
"	31 —4 " "	"	4.40

No.	32 —5 Row, All Bristles	per doz.	\$5.15
"	33 —6 " "	"	5.85

Large Bent Pattern.

No.	20 —3 Row, Mixed Hair.....	"	4.40
"	21 —4 " "	"	5.15
"	22 —5 " "	"	5.85
"	23 —6 " "	"	6.60

HORSE BRUSHES



No. 216, WOODEN BACK

Solid Backs, Warranted not to come off.



No. 217, LEATHER BACK

Best Quality Russet Backs and Straps, Handsomely Finished, Machine Sewed.

No. 20—Union.....	per doz.	\$ 3.35	No. 110—Mixed Hair.....	per doz.	\$ 7.35
" 21—"	"	4.65	" 111—"	"	9.35
" 22—"	"	6.00	" 120—All Black.....	"	8.65
" 30—Mixed Centre, Black Edge.....	"	7.35	" 121—"	"	11.35
" 31—"	"	8.65	" 130—Yellow Im. OK.....	"	12.00
" 32—"	"	10.00	" 131—"	"	14.65
" 40—"	White Edge.....	9.35	" 140—White Bristles.....	"	22.65
" 41—"	"	11.35	" 141—"	"	20.65
" 42—"	"	13.35	" 150—Grey Bristles, Stiff.....	"	32.00

DANDY BRUSHES



Patent Solid Backs, Warranted not to come off.

Nos.....	20	25	200	45		
Acne Whisk.....	per doz.	\$3.00	3.80	4.00	5.75	
Nos.....	108	60	62	100		
Super Whisk, with Leather Sides.....	per doz.	4.50	9.25	15.00		
Nos.....	5	370	50	51	52	
All Kittool, Black.....	per doz.	\$8.65	6.00	8.00	11.00	14.00
Nos.....	111	70	72	16.00		
All Kittool, with Leather Sides.....	per doz.	8.00	11.50	16.00		

STABLE BROOMS



No. 226, BASS STABLE BROOMS

Best Bahla Bass. Handles included.

Nos.....	3	4	5	6
Per dozen.....	\$11.00	15.00	18.50	21.00

No. 227, CANE STABLE BROOMS

Best Quality Cane. Handles included.

Nos.....	3	4	5	6
Per dozen.....	\$10.00	12.00	14.00	16.00

EXTRA HANDLES

Medium Hardwood, for Nos. 3 and 4.....	per doz.	\$1.00
Large Hardwood, for Nos. 5 and 6.....	"	1.25
Extra Large and Heavy.....	"	2.00

CARRIAGE BOLTS



WITH SHORT SQUARE, AND TRIMMED HEADS

Price per Hundred

LENGTH.	2-16 and 1-4 Inch.	5-16 Inch	3-8 Inch.	7-16 Incl	inch.	9-16 and 5-8 Inch.	3-4 Inch.
1 ¹ / ₄ Inch	\$1.00	\$1.20	\$1.50	\$2.20	\$3.00	\$5.00	\$7.20
1 ¹ / ₂ "	1.04	1.25	1.50	2.20	3.00	5.00	7.20
2 "	1.08	1.30	1.50	2.20	3.00	5.00	7.20
2 ¹ / ₄ "	1.12	1.35	1.57	2.28	3.00	5.00	7.20
2 ¹ / ₂ "	1.16	1.40	1.64	2.30	3.00	5.00	7.20
2 ³ / ₄ "	1.20	1.45	1.71	2.44	3.00	5.00	7.20
3 "	1.24	1.50	1.78	2.52	3.00	5.00	7.20
3 ¹ / ₄ "	1.28	1.55	1.85	2.60	3.10	5.15	7.40
3 ¹ / ₂ "	1.32	1.60	1.92	2.68	3.20	5.30	7.60
3 ³ / ₄ "	1.36	1.65	1.99	2.76	3.30	5.45	7.80
4 "	1.40	1.70	2.06	2.84	3.40	5.60	8.00
4 ¹ / ₄ "	1.44	1.75	2.13	2.92	3.50	5.75	8.20
4 ¹ / ₂ "	1.48	1.80	2.20	3.00	3.60	5.90	8.40
4 ³ / ₄ "	1.52	1.85	2.27	3.08	3.70	6.05	8.60
5 "	1.56	1.90	2.34	3.16	3.80	6.20	8.80
5 ¹ / ₄ "	1.64	2.00	2.48	3.32	4.00	6.50	9.20
6 "	1.72	2.10	2.62	3.48	4.20	6.80	9.60
6 ¹ / ₄ "	1.80	2.20	2.76	3.64	4.40	7.10	10.00
7 "	1.88	2.30	2.90	3.80	4.60	7.40	10.40
7 ¹ / ₄ "	1.96	2.40	3.04	3.96	4.80	7.70	10.80
8 "	2.04	2.50	3.18	4.12	5.00	8.00	11.20
8 ¹ / ₄ "	2.12	2.60	3.32	4.28	5.20	8.30	11.60
9 "	2.20	2.70	3.46	4.44	5.40	8.60	12.00
9 ¹ / ₄ "	2.28	2.80	3.60	4.60	5.60	8.90	12.40
10 "	2.36	2.90	3.74	4.76	5.80	9.20	12.80
11 "	2.52	3.10	4.02	5.08	6.20	9.80	13.60
12 "	2.68	3.30	4.30	5.40	6.60	10.40	14.40
13 "	2.84	3.50	4.58	5.72	7.00	11.00	15.20
14 "	3.00	3.70	4.86	6.04	7.40	11.60	16.00
15 "	3.16	3.90	5.14	6.36	7.80	12.20	16.80
16 "	3.32	4.10	5.42	6.68	8.20	12.80	17.60
17 "	3.48	4.30	5.70	7.00	8.60	13.40	18.40
18 "	3.64	4.50	5.98	7.32	9.00	14.00	19.20
19 "	3.80	4.70	6.26	7.64	9.40	14.60	20.00
20 "	3.96	4.90	6.54	7.96	9.80	15.20	20.80
Advance per inch	0.16	0.20	0.28	0.32	0.40	0.00	0.80

Lengths under 1 inch charged at same price as 1 inch. Any of the above ordered with Hexagon Nuts will be charged 10 per cent. extra. Any lengths between those named on this list will be charged at the succeeding price.

SHAFT BOLTS

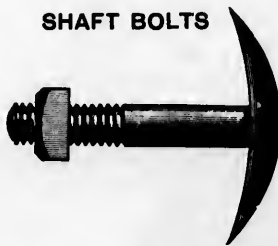

³/₁₆ and ¹/₄ Inch

Length.....	1	1 ¹ / ₄	1 ¹ / ₂	1 ³ / ₄	2	2 ¹ / ₄	2 ¹ / ₂	2 ³ / ₄	3	3 ¹ / ₂	4 inch.
Price.....per hundred	\$3.00	3.10	3.20	3.30	3.40	3.50	3.60	3.70	3.80	4.00	4.20

⁵/₁₆ Inch

Length.....	1	1 ¹ / ₄	1 ¹ / ₂	1 ³ / ₄	2	2 ¹ / ₄	2 ¹ / ₂	2 ³ / ₄	3	3 ¹ / ₂	4 inch.
Price.....per hundred	\$4.00	4.00	4.00	4.00	4.10	4.20	4.40	4.50	4.70	5.00	5.30

MACHINE BOLTS



WITH SQUARE HEADS AND NUTS

Price per Hundred

1 and 5/8 Inch.	3/4 Inch.
\$5.00	\$7.20
5.00	7.20
5.00	7.20
5.00	7.20
5.00	7.20
5.00	7.20
5.00	7.20
5.00	7.20
5.15	7.40
5.30	7.60
5.45	7.80
5.60	8.00
5.75	8.20
5.90	8.40
6.05	8.60
6.20	8.80
6.35	9.00
6.50	9.20
6.65	9.40
6.80	9.60
6.95	9.80
7.10	10.00
7.25	10.20
7.40	10.40
7.55	10.60
7.70	10.80
7.85	11.00
8.00	11.20
8.15	11.40
8.30	11.60
8.45	11.80
8.60	12.00
8.75	12.20
8.90	12.40
9.05	12.60
9.20	12.80
9.35	13.00
9.50	13.20
9.65	13.40
9.80	13.60
9.95	13.80
10.10	14.00
10.25	14.20
10.40	14.40
10.55	14.60
10.70	14.80
10.85	15.00
11.00	15.20

LENGTH.	1/4	3/16	1/8	7/16	1/2	5/16 & 3/8	3/4	7/8	1
1 1/2 Inch	\$1.70	2.00	2.40	2.80	3.00	5.20	7.20	10.00	14.40
2 "	1.78	2.10	2.52	2.98	3.10	5.50	7.64	10.00	15.20
2 1/2 "	1.86	2.20	2.64	3.12	3.20	5.80	8.08	11.20	16.00
3 "	1.94	2.30	2.76	3.26	3.30	6.10	8.52	11.80	16.80
3 1/2 "	2.02	2.40	2.88	3.44	3.40	6.40	9.06	12.40	17.00
4 "	2.10	2.50	3.00	3.60	3.50	6.70	9.40	13.00	18.40
4 1/2 "	2.18	2.60	3.12	3.76	3.60	7.00	9.84	13.60	19.20
5 "	2.26	2.70	3.24	3.92	3.70	7.30	10.28	14.20	20.00
5 1/2 "	2.34	2.80	3.36	4.08	3.80	7.60	10.72	14.80	20.80
6 "	2.42	2.90	3.48	4.24	3.90	7.90	11.16	15.40	21.60
6 1/2 "	2.50	3.00	3.60	4.40	4.00	8.20	11.60	16.00	22.40
7 "	2.58	3.10	3.72	4.56	4.10	8.50	12.04	16.60	23.20
7 1/2 "	2.66	3.20	3.84	4.72	4.20	8.80	12.48	17.20	24.00
8 "	2.74	3.30	3.96	4.88	4.30	9.10	12.92	17.80	24.80
8 1/2 "	2.82	3.40	4.08	5.04	4.40	9.40	13.36	18.40	25.60
9 "	2.90	3.50	4.20	5.20	4.50	9.70	13.80	19.00	26.40
9 1/2 "	2.98	3.60	4.32	5.36	4.60	10.00	14.24	19.60	27.20
10 "	3.06	3.70	4.44	5.52	4.70	10.30	14.68	20.20	28.00
10 1/2 "	3.14	3.80	4.56	5.68	4.80	10.60	15.12	20.80	28.80
11 "	3.22	3.90	4.68	5.84	4.90	10.90	15.56	21.40	29.60
11 1/2 "	3.30	4.00	4.80	6.00	5.00	11.20	16.00	22.00	30.40
12 "	3.38	4.10	4.92	6.16	5.10	11.50	16.44	22.60	31.20
12 1/2 "	3.46	4.20	5.04	6.32	5.20	11.80	16.88	23.20	32.00
13 "	3.54	4.30	5.16	6.48	5.30	12.10	17.32	23.80	32.80
13 1/2 "	3.62	4.40	5.28	6.64	5.40	12.40	17.76	24.40	33.60
14 "	3.70	4.50	5.40	6.80	5.50	12.70	18.20	25.00	34.40
14 1/2 "	3.78	4.60	5.52	6.96	5.60	13.00	18.64	25.60	35.20
15 "	3.86	4.70	5.64	7.12	5.70	13.30	19.08	26.20	36.00
15 1/2 "	3.94	4.80	5.76	7.28	5.80	13.60	19.52	26.80	36.80
16 "	4.02	4.90	5.88	7.44	5.90	13.90	19.96	27.40	37.60
16 1/2 "	4.10	5.00	6.00	7.60	6.00	14.20	20.40	28.00	38.40
17 "	4.18	5.10	6.12	7.76	6.10	14.50	20.84	28.60	39.20
17 1/2 "	4.26	5.20	6.24	7.92	6.20	14.80	21.28	29.20	40.00
18 "	4.34	5.30	6.36	8.08	6.30	15.10	21.72	29.80	40.80
18 1/2 "	4.42	5.40	6.48	8.24	6.40	15.40	22.16	30.40	41.60
19 "	4.50	5.50	6.60	8.40	6.50	15.70	22.60	31.00	42.40
19 1/2 "	4.58	5.60	6.72	8.56	6.60	16.00	23.04	31.60	43.20
20 "	4.66	5.70	6.84	8.72	6.70	16.30	23.48	32.20	44.00
Advance per Inch } above 20 inches .. }	\$0.16	0.20	0.24	0.32	0.40	0.60	0.88	1.20	1.00

Bolts with Hexagon Heads or Hexagon Nuts will be charged 10 per cent. extra. If both Hexagon Heads and Hexagon Nuts 20 per cent. extra. Lengths under 1 1/2 inch charged at same price as 1 1/2 inch. Any lengths between those named on this list will be charged at the succeeding price.

Hexagon Nuts will be charged at the succeeding price.

TORONTO, ONT.
WROUGHT FLOOR HOOKS

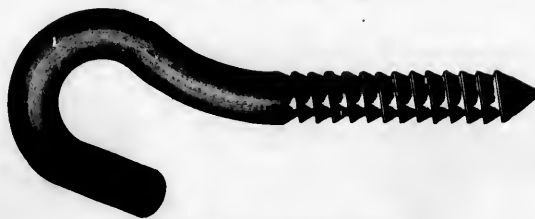

WITH COACH SCREW THREAD

3 1/2	4
4.00	4.20
3 1/2	4
5.00	5.30

Length	6	7	7
Diameter	5/8	3/4	1
Per hundred	\$8.00	8.70	10.00

BOLT ENDS WITH SQUARE NUTS



Size of Iron.....	5/16	3/8	7/16	1/2	5/8	3/4	7/8	1	1 1/8	1 1/4	1 3/8	1 1/2	1 5/8	1 3/4	1 7/8	2	inch.
Length.....	6	7	7	8	9	10	11	12	13	14	15	16	17	18	19	20	"
Price per lb.....	\$0.20	0.18	0.16	0.14	0.12	0.10	0.10	0.10	0.10	0.11	0.11	0.11	0.12	0.12	0.12	0.12	

Bolt Ends with Hexagon Nuts will be charged 10 per cent. extra.

TURNBUCKLES

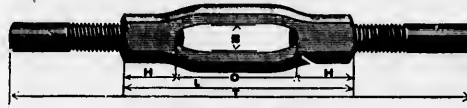

WROUGHT IRON

Open hexagonal shape, complete with Right and Left Bolt Ends. The ends are machine finished or chamfered, and reamed and counter chamfered the depth of one thread before tapping, giving easy entrance to the bolt. These buckles are made with extra length of thread and have a perfect wrench hold.

Dimensions—B size, diameter of screw; O, opening between heads 5 1/2 inches. First length for all sizes: H, length of tapped head; L, length of buckle without bolt ends; T, total length of buckle and bolt ends.

Size B	PRICE, EACH	O	H	L	T	Weight with Bolt Ends.
Inches.		Inches.	Inches.	Inches.	Inches.	Pounds.
1/2	\$0.40	5 1/2	7	7 1/2	22	1 1/2
5/8	0.42	5 1/2	7 1/4	7 3/4	22	2
3/4	0.45	5 1/2	1	7 1/2	22	2 1/2
7/8	0.48	5 1/2	1 1/4	7 1/2	22	2 3/4
1	0.50	5 1/2	1 1/2	7 1/2	22	3 1/4
1 1/8	0.63	5 1/2	1 3/4	8 1/2	23	4 1/4
1 1/4	0.75	5 1/2	1 7/8	8 3/4	24	5 1/4
1 1/2	0.88	5 1/2	2	9	25	7 1/4
1 3/4	1.00	5 1/2	2 1/4	9 3/4	25	8 3/4
2	1.25	5 1/2	2 3/8	9 3/4	26	11 1/4
2 1/4	1.38	5 1/2	2 1/2	10 1/4	27	14 1/4
2 1/2	1.50	5 1/2	2 3/4	10 1/2	27	17
2 3/4	2.00	5 1/2	2 7/8	11 1/4	28	25
3	2.65	5 1/2	3 1/8	12	29	29
3 1/4	3.50	5 1/2	3 3/8	12 1/2	30	46
3 1/2	4.50	5 1/2	4	13 1/4	32	60
3 3/4	5.50	5 1/2	4 1/4	14 1/4	33	73
4	6.50	5 1/2	4 1/2	15	34	85

The above prices are for standard length buckles, viz.: 5 1/2 inches clear between heads. Extra lengths furnished to order. Weights given are only approximate.

MALLEABLE IRON THUMB SCREWS AND NUTS THREADED



Diameter.....		3/16	1/4	5/16	3/8	7/16	1/2	inch.
Threads to the inch.....		30	20	18	16	14	12	
Thumb Screws, 3/4 inch long.....	per 100	\$2.00	2.80	3.70	
" " 1 ".....	"	3.00	4.00	5.00	
Thumb Nuts.....	"	0.75	0.75	1.00	1.25	1.50	2.00	

COACH OR LAG SCREWS



GIMLET POINT

Price per Hundred

LENGTH.	¼ & ⅝ Inch.	¾ Inch.	⅞ Inch.	½ Inch.	⅝ & ⅞ Inch.	¾ Inch.	⅞ Inch.	1 Inch.
1½ Inch	\$2.25	\$2.70	\$3.15	\$3.75				
2 "	2.40	2.88	3.30	4.05	\$4.05			
2½ "	2.55	3.06	3.63	4.45	5.40	\$7.02		
3 "	2.70	3.24	3.87	4.65	5.85	8.58	\$12.90	
3½ "	2.85	3.42	4.11	4.85	6.30	9.24	13.20	\$18.00
4 "	3.00	3.60	4.35	5.25	6.75	9.90	14.10	19.80
4½ "	3.15	3.78	4.59	5.55	7.20	10.56	15.00	21.00
5 "	3.30	3.96	4.83	5.85	7.65	11.22	15.90	22.20
5½ "	3.45	4.14	5.07	6.15	8.10	11.88	16.80	23.40
6 "	3.60	4.32	5.31	6.45	8.55	12.54	17.70	24.60
6½ "	3.75	4.50	5.55	6.75	9.00	13.20	18.60	25.80
7 "	3.90	4.68	5.79	7.05	9.45	13.86	19.50	27.00
7½ "	4.05	4.86	6.03	7.35	9.90	14.52	20.40	28.20
8 "	4.20	5.04	6.27	7.65	10.35	15.18	21.30	29.40
9 "	4.50	5.40	6.75	8.25	11.25	16.50	23.10	31.80
10 "	4.80	5.76	7.23	8.85	12.15	17.82	24.90	34.20
11 "	5.10	6.12	7.71	9.45	13.05	19.14	26.70	36.60
12 "	5.40	6.48	8.19	10.05	13.95	20.46	28.50	39.00

1 1/8 2 inch.
19 20 "
0.12 0.12

ed or champered,
ance to the bolt.

sizes: H, length
t ends.

Weight with Bolt Ends.
Pounds.
1½
2
2½
3
3½
4
5
7
8
11
14
17
25
29
46
60
73
85

Lengths over 12 inch will be charged in proportion to above. Hexagon Heads, 10 per cent. extra. Slot Heads, 20 per cent. extra. Skein Bolts charged same list as Coach Screws.

FLOW AND GUARD BOLTS



No. 1, KEY HEAD



No. 2, ROUND HEAD



No. 3, SHORT SQUARE



No. 4, SQUARE HEAD

In ordering Plow Bolts, please state what style heads are desired, and whether right or left hand threads.

Price per Hundred

LENGTH.	¼ Inch.	⅝ Inch.	⅞ Inch.	½ Inch.	⅝ Inch.	¾ Inch.
1½ inch	\$1.70	\$2.00	\$2.60	\$3.50	\$4.50	\$5.70
1¾ "	1.80	2.10	2.75	3.70	4.75	6.00
2 "	1.90	2.20	2.90	3.90	5.00	6.30
2½ "	2.00	2.30	3.05	4.10	5.25	6.60
3 "	2.10	2.40	3.20	4.30	5.50	6.90
3½ "	2.20	2.50	3.35	4.50	5.75	7.20
4 "	2.30	2.60	3.50	4.70	6.00	7.50
4½ "	2.40	2.70	3.65	4.90	6.25	7.80
5 "	2.50	2.80	3.80	5.10	6.50	8.10
5½ "	2.60	2.90	3.95	5.30	6.75	8.40
6 "	2.70	3.00	4.10	5.50	7.00	8.70
6½ "	2.80	3.10	4.25	5.70	7.25	9.00

½ inch.
12
8.00
2.00

TIRE BOLTS

Price per Hundred.



½ & ⅝ Inch.		¼ Inch.		⅝ Inch.		¾ Inch.	
1 Inch.....	\$0.60	1 Inch.....	\$0.80	1 Inch.....	\$1.10	1 Inch.....	\$2.20
1½ ".....	0.60	1½ ".....	0.80	1½ ".....	1.10	1½ ".....	2.20
1¾ ".....	0.60	1¾ ".....	0.80	1¾ ".....	1.10	1¾ ".....	2.20
2 ".....	0.65	2 ".....	0.85	2 ".....	1.10	2 ".....	2.20
2½ ".....	0.70	2½ ".....	0.90	2½ ".....	1.17	2½ ".....	2.20
3 ".....	0.75	3 ".....	0.95	3 ".....	1.24	3 ".....	2.30
3½ ".....	0.80	3½ ".....	1.00	3½ ".....	1.31	3½ ".....	2.40
4 ".....	0.85	4 ".....	1.05	4 ".....	1.38	4 ".....	2.50
4½ ".....	0.90	4½ ".....	1.10	4½ ".....	1.45	4½ ".....	2.60
5 ".....	0.95	5 ".....	1.15	5 ".....	1.52	5 ".....	2.70
5½ ".....	1.00	5½ ".....	1.20	5½ ".....	1.59	5½ ".....	2.80
6 ".....	1.05	6 ".....	1.25	6 ".....	1.66	6 ".....	2.90
6½ ".....	1.10	6½ ".....	1.30	6½ ".....	1.73	6½ ".....	3.00
7 ".....	1.15	7 ".....	1.35	7 ".....	1.80	7 ".....	3.10
7½ ".....	1.20	7½ ".....	1.40	7½ ".....	1.87	7½ ".....	3.20
8 ".....	1.25	8 ".....	1.45	8 ".....	1.94	8 ".....	3.30
8½ ".....	1.30	8½ ".....	1.50	8½ ".....	2.01	8½ ".....	3.40
9 ".....	1.40	9 ".....	1.60	9 ".....	2.15	9 ".....	3.60
9½ ".....	1.50	9½ ".....	1.70	9½ ".....	2.29	9½ ".....	3.80

SLEIGH SHOE BOLTS

Price per Hundred



LENGTH.	⅝ & ¼ Inch.	⅝ Inch.	¾ Inch.	⅞ Inch.	1 Inch.	1 1/8 Inch.
1½ Inch.....	\$1.90					
1¾ ".....	2.00	2.70				
2 ".....	2.15	2.85				
2½ ".....	2.25	3.05	5.00	7.40	9.00	13.40
3 ".....	2.50	3.35	5.40	7.80	9.50	14.20
3½ ".....	2.75	3.65	5.80	8.20	10.00	15.00
4 ".....	3.00	3.95	6.20	8.60	10.50	15.80
4½ ".....	3.25	4.25	6.60	9.00	11.00	16.60
5 ".....		4.55	7.00	9.40	11.50	17.40
5½ ".....		4.90	7.40	9.80	12.00	18.20
6 ".....		5.20	7.80	10.20	12.50	19.00
6½ ".....		5.55	8.20	10.60	13.00	19.80
7 ".....		5.85	8.60	11.00	13.50	20.60
7½ ".....		6.20	9.00	11.40	14.00	21.40
8 ".....		6.50	9.40	11.80	14.50	22.20
8½ ".....		6.85	9.80	12.20	15.00	23.00

SCREW EYE BOLTS



No. 239

NUT EYE BOLTS

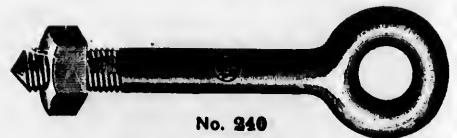

No. 240

Diameter of Iron.....	¼	⅝	¾	⅞	1	1 1/8	1 1/4	1 1/2	1 3/4	2	inch.
Diameter of Eye.....	1	1 1/8	1 1/4	1 1/2	1 3/4	2	2 1/8	2 1/4	2 1/2	2 3/4	"
Length.....	2	2 1/2	3	3 1/2	4	4 1/2	5	5 1/2	6	6 1/2	"
No. 239—Screw Eye Bolts, Plain.....	per doz.	\$1.10	1.30	1.50	1.90	2.25	2.95	5.90	7.75	9.00	
" 239G " " Galvanized.....	"	1.20	1.40	1.60	2.00	2.40	3.20	5.80	8.50	10.00	
" 240—Nut Eye Bolts, Plain.....	"	1.20	1.40	1.60	2.10	2.40	3.20	5.80	8.00	10.00	
" 240G " " Galvanized.....	"	1.40	1.60	1.80	2.30	2.60	3.60	6.20	9.00	11.00	

STOVE BOLTS

With Forged Nuts.



FLAT HEAD

$\frac{5}{16}$, $\frac{3}{8}$ and $\frac{7}{16}$ Inch

Length.....	$\frac{1}{2}$	$\frac{5}{8}$	$\frac{3}{4}$	$\frac{7}{8}$	1	1 $\frac{1}{4}$	1 $\frac{1}{2}$	1 $\frac{3}{4}$	2	2 $\frac{1}{4}$	2 $\frac{1}{2}$	2 $\frac{3}{4}$	3 inch.
Price..... per hundred	\$0.60	0.60	0.60	0.65	0.65	0.70	0.75	0.80	0.85	0.90	0.95	1.00	1.05

$\frac{1}{4}$ Inch

Length.....	$\frac{1}{2}$	$\frac{5}{8}$	$\frac{3}{4}$	$\frac{7}{8}$	1	1 $\frac{1}{4}$	1 $\frac{1}{2}$	1 $\frac{3}{4}$	2	2 $\frac{1}{4}$	2 $\frac{1}{2}$	2 $\frac{3}{4}$	3 inch.
Price..... per hundred	\$0.65	0.65	0.70	0.70	0.70	0.75	0.80	0.85	0.90	0.95	1.00	1.05	1.10

$\frac{5}{16}$ Inch

Length.....	$\frac{1}{2}$	$\frac{5}{8}$	$\frac{3}{4}$	$\frac{7}{8}$	1	1 $\frac{1}{4}$	1 $\frac{1}{2}$	1 $\frac{3}{4}$	2	2 $\frac{1}{4}$	2 $\frac{1}{2}$	2 $\frac{3}{4}$	3 inch.
Price..... per hundred	\$1.05	1.10	1.10	1.15	1.15	1.20	1.25	1.30	1.35	1.40	1.45	1.50	

$\frac{3}{8}$ Inch

Length.....	$\frac{1}{2}$	$\frac{5}{8}$	$\frac{3}{4}$	$\frac{7}{8}$	1	1 $\frac{1}{4}$	1 $\frac{1}{2}$	1 $\frac{3}{4}$	2	2 $\frac{1}{4}$	2 $\frac{1}{2}$	2 $\frac{3}{4}$	3 inch.
Price..... per hundred	\$2.20	2.20	2.20	2.20	2.20	2.20	2.20	2.20	2.30	2.40	2.50	2.60	

ROUND HEAD

$\frac{5}{16}$, $\frac{3}{8}$ and $\frac{7}{16}$ Inch

Length.....	$\frac{1}{2}$	$\frac{5}{8}$	$\frac{3}{4}$	$\frac{7}{8}$	1	1 $\frac{1}{4}$	1 $\frac{1}{2}$	1 $\frac{3}{4}$	2	2 $\frac{1}{4}$	2 $\frac{1}{2}$	2 $\frac{3}{4}$	3 inch.
Price..... per hundred	\$0.55	0.55	0.55	0.90	0.90	0.95	0.95	1.00	1.05	1.10	1.15	1.20	

$\frac{1}{4}$ Inch

Length.....	$\frac{5}{8}$	$\frac{3}{4}$	$\frac{7}{8}$	1	1 $\frac{1}{4}$	1 $\frac{1}{2}$	1 $\frac{3}{4}$	2	2 $\frac{1}{4}$	2 $\frac{1}{2}$	2 $\frac{3}{4}$	3 inch.
Price..... per hundred	\$0.95	0.95	1.00	1.00	1.05	1.10	1.15	1.20	1.25	1.30		

SINK BOLTS

With Two Nuts.



$\frac{1}{4}$ Inch

Length.....	1	1 $\frac{1}{4}$	1 $\frac{1}{2}$	1 $\frac{3}{4}$	2	2 $\frac{1}{4}$	2 $\frac{1}{2}$	2 $\frac{3}{4}$	3	3 $\frac{1}{2}$	4	inch.
Price..... per hundred	\$1.50	1.35	1.40	1.45	1.50	1.55	1.60	1.65	1.70	1.80	1.90	

ELEVATOR BOLTS

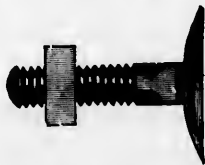

For Bolting Buckets to Grain Elevators.

WROUGHT IRON

$\frac{3}{4}$ and 1 inch long by $\frac{1}{2}$ or $\frac{3}{4}$ inch diameter.....	per hundred	\$2.20
1 " 1 $\frac{1}{2}$ " " " $\frac{3}{4}$ inch diameter.....	"	3.00

$\frac{3}{8}$ Inch.	
h.....	\$2.20
.....	2.20
.....	2.20
.....	2.20
.....	2.20
.....	2.30
.....	2.40
.....	2.50
.....	2.60
.....	2.70
.....	2.80
.....	2.90
.....	3.00
.....	3.10
.....	3.20
.....	3.30
.....	3.40
.....	3.60
.....	3.80

.....	$\frac{5}{8}$ Inch.
.....	13.40
.....	14.20
.....	15.00
.....	15.80
.....	16.60
.....	17.40
.....	18.20
.....	19.00
.....	19.80
.....	20.60
.....	21.40
.....	22.20
.....	23.00

$\frac{3}{8}$	1	inch.
1 $\frac{1}{2}$	1 $\frac{1}{2}$	"
5	6	"
7.75	9.00	
8.50	10.00	
8.00	10.00	
9.00	11.00	



IRON MACHINE SCREWS

COUNTERSUNK AND ROUND HEAD

Price per Gross



NUMBERS.	2 to 4	6	8	10	12	14	16	18	20	24
Length, 1/2 Inch	\$0.23	\$0.24	\$0.27	\$0.32						
" " "	0.23	0.24	0.27	0.32	\$0.36	\$0.45	\$0.55			
" " "	0.23	0.24	0.27	0.34	0.38	0.45	0.55	\$0.60	\$0.65	\$0.75
" " "	0.26	0.29	0.34	0.38	0.43	0.48	0.60	0.65	0.75	0.80
" " "	0.30	0.34	0.38	0.42	0.48	0.53	0.60	0.67	0.80	0.85
" " "		0.37	0.42	0.47	0.53	0.59	0.67	0.75	0.85	1.05
" 1 "		0.41	0.46	0.51	0.58	0.65	0.73	0.81	0.91	1.15
" 1 1/2 "			0.55	0.60	0.68	0.76	0.85	0.95	1.05	1.35
" 1 1/2 "				0.70	0.80	0.90	1.00	1.15	1.25	1.60

BRASS MACHINE SCREWS

COUNTERSUNK AND ROUND HEAD

Price per Gross

NUMBERS.	2 to 4	6	8	10	12	14	16	18	20	24
Length, 1/2 Inch	\$0.29	\$0.33	\$0.45	\$0.60						
" " "	0.29	0.33	0.45	0.60	\$0.75	\$1.00	\$1.25			
" " "	0.32	0.36	0.50	0.65	0.85	1.10	1.35	\$1.75	\$2.10	\$3.15
" " "	0.40	0.45	0.55	0.75	0.95	1.20	1.50	1.90	2.50	3.50
" " "	0.50	0.55	0.65	0.85	1.05	1.30	1.65	2.05	2.75	3.75
" " "		0.65	0.75	1.00	1.20	1.45	1.80	2.20	2.85	4.00
" 1 "		0.75	0.90	1.10	1.35	1.60	1.95	2.35	3.10	4.75
" 1 1/2 "			1.10	1.40	1.80	2.25	2.65	3.75	5.30	
" 1 1/2 "				1.65	1.90	2.20	2.60	3.20	4.15	6.05

The table below gives sizes, in parts of an inch, of the different numbers of screws in the above lists:—

No.	2	3	4	6	8	10	12	14	16	18	20	24
No. of Threads to inch	56	48	36	32	24	24	20	20	16	16	14	14
Size of Drill for Tapping	49	45	42	35	30	25	17	6	3	3	1 1/4	1 1/4

Letter S abbreviation for small; letter L for large.



BOILER PATCH BOLT

PATCH AND PLANER HEAD BOLTS

BOILER PATCH BOLTS

Turned and Threaded. Price per 100.

Diameter	1/2	5/8	3/4	7/8	1 inch.
Length, 1/2 inch	\$3.75	4.25	4.50	6.00	13.50
" 1 "	4.25	4.90	6.50	9.50	14.00
" 1 1/2 "		5.10	6.80	9.85	14.00
" 1 1/2 "			5.50	7.25	10.25

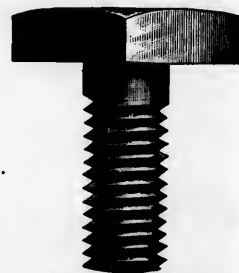

PLANER HEAD BOLT

PLANER HEAD BOLTS

Without Nuts. Price per 100.

Diameter of Head	7/8	1	1 1/8	1 1/2	1 3/4 inch.
Length	1 1/2	1 1/2	1 1/2	1 1/2	1 1/2
Diameter of Screw	1 1/2	1 1/2	1 1/2	1 1/2	1 1/2
Length, 1 inch	\$10.00	10.50	12.00	13.30	17.00
" 1 1/2 "		10.50	12.25	14.00	17.50
" 1 3/4 "			12.45	14.80	18.00
" 2 "			13.75	15.70	19.00

CAP AND SET SCREWS



HEXAGON HEAD
CAP SCREW



SQUARE HEAD
CAP SCREW



SET SCREW



STUD

DIFFERENT KINDS OF SET SCREW POINTS



OVAL CUP SQUARE FLAT POINTED

Price per Hundred

DIAMETER OF SCREW.		1/4	5/16	3/8	7/16	1/2	5/8	3/4	7/8	1
3/8 Inch.	Set.....	2.00	2.20	2.50	2.90	3.40	4.25	5.00
	Square Head Cap.....	2.40	2.75	3.20	3.80	4.40	5.75
	Hexagon Head Cap.....	3.00	3.25	3.75	4.40	5.50	7.00
1/2 Inch.	Set.....	2.15	2.35	2.65	3.10	3.60	4.25	5.00	7.00
	Square Head Cap.....	2.60	2.95	3.40	4.00	4.70	5.75	7.70
	Hexagon Head Cap.....	3.25	3.50	4.00	4.70	5.70	7.00	9.50
1 1/4 Inch.	Set.....	2.30	2.50	2.80	3.30	3.80	4.50	5.25	7.00	11.30
	Square Head Cap.....	2.75	3.10	3.65	4.20	4.95	6.05	7.70	10.50
	Hexagon Head Cap.....	3.50	3.75	4.25	5.00	6.00	7.50	9.50	12.20
1 1/2 Inch.	Set.....	2.45	2.65	2.95	3.50	4.00	4.75	5.50	7.50	11.30
	Square Head Cap.....	2.90	3.30	3.85	4.45	5.25	6.35	8.25	10.50	14.00
	Hexagon Head Cap.....	3.75	4.00	4.50	5.30	6.30	8.00	10.00	12.20	16.00
1 3/4 Inch.	Set.....	2.60	2.80	3.10	3.70	4.20	5.00	5.75	8.00	12.00
	Square Head Cap.....	3.05	3.50	4.10	4.70	5.55	6.65	8.80	11.10	14.80
	Hexagon Head Cap.....	4.00	4.25	4.75	5.60	6.60	8.50	10.60	12.80	16.60
2 Inch.	Set.....	2.80	3.00	3.30	3.95	4.45	5.30	6.05	8.60	12.00
	Square Head Cap.....	3.25	3.70	4.35	4.95	5.90	7.05	9.40	11.80	15.70
	Hexagon Head Cap.....	4.25	4.00	5.05	5.95	7.00	9.10	11.20	13.40	17.20
2 1/4 Inch.	Set.....	3.25	3.55	4.25	4.75	5.65	6.40	9.30	13.80
	Square Head Cap.....	4.00	4.65	5.25	6.30	7.55	10.10	12.60	16.70
	Hexagon Head Cap.....	5.00	5.40	6.85	7.60	9.70	11.90	14.10	17.90
2 1/2 Inch.	Set.....	3.85	4.00	5.10	6.05	6.80	10.00	14.80
	Square Head Cap.....	5.00	5.60	6.75	8.15	10.90	13.50	17.80
	Hexagon Head Cap.....	5.80	6.80	8.00	10.40	12.70	14.90	18.80
2 3/4 Inch.	Set.....	5.00	5.50	6.50	7.25	10.80	15.90
	Square Head Cap.....	6.00	7.25	8.85	11.80	14.60	19.10
	Hexagon Head Cap.....	4.25	7.30	8.60	11.20	13.60	15.90	20.00
3 Inch.	Set.....	5.95	7.00	7.75	11.70	17.10
	Square Head Cap.....	7.80	9.65	12.80	15.90	20.60
	Hexagon Head Cap.....	4.40	5.10	9.30	12.10	14.70	17.00	21.80
No. Threads to Inch.....	20	18	16	14	12	12	11	10	9	8

Headless Set (or Grub) Screws, Slotted, Threaded over all, use Set Screw list.

In ordering Set Screws, state the kind of point you wish. Case Hardened Set Screws with Cup Points only are kept in stock, others made to order. Shoulder Screws and all other special styles made to order.

20	24
\$0.65	\$0.75
0.75	0.90
0.80	0.96
0.85	1.05
0.91	1.15
1.05	1.35
1.25	1.60

20	24
\$2.10	\$3.15
2.50	3.50
2.75	3.75
2.85	4.00
3.10	4.75
3.75	5.30
4.15	6.05

See above lists:-

20	24
1 1/4 L	1 1/2 L
16	16
17	17



HEX HEAD BOLT

1 1/4 inch.
1 1/2 inch.
1 3/4 inch.

17.00
17.50
18.00
19.00



NUTS

HOT PRESSED



MANUFACTURERS' STANDARD LIST

SQUARE						HEXAGON							
Order Number.	Size Square.	Thickness	Diameter of Hole.	Size of Bolt.	Price per 100 lbs.	Average Number in 100 lbs.	Order Number.	Size Square.	Thickness.	Diameter of Hole.	Size of Bolt.	Price per 100 lbs.	Average Number in 100 lbs.
1*	1 1/2	1/8	1 1/2	1 1/2	\$30.00	14700	35*	1 1/2	1/8	1 1/2	1 1/2	\$20.00	8700
2*	1 1/2	1/8	1 1/2	1 1/2	13.00	7500	36*	1 1/2	1/8	1 1/2	1 1/2	16.00	4200
3*	1 1/2	1/8	1 1/2	1 1/2	11.50	4000	37*	1 1/2	1/8	1 1/2	1 1/2	13.00	2600
4*	1 1/2	1/8	1 1/2	1 1/2	10.00	2200	38*	1 1/2	1/8	1 1/2	1 1/2	12.00	2280
5*	1 1/2	1/8	1 1/2	1 1/2	9.00	2100	39*	1 1/2	1/8	1 1/2	1 1/2	11.20	1500
6*	1 1/2	1/8	1 1/2	1 1/2	9.00	1350	40	1 1/2	1/8	1 1/2	1 1/2	11.20	1700
7*	1 1/2	1/8	1 1/2	1 1/2	9.00	1050	41*	1 1/2	1/8	1 1/2	1 1/2	11.20	1450
8*	1 1/2	1/8	1 1/2	1 1/2	8.70	1000	42*	1 1/2	1/8	1 1/2	1 1/2	10.50	1100
9*	1 1/2	1/8	1 1/2	1 1/2	8.70	1020	43*	1 1/2	1/8	1 1/2	1 1/2	10.50	1220
10	1 1/2	1/8	1 1/2	1 1/2	8.50	600	44	1 1/2	1/8	1 1/2	1 1/2	10.30	700
11*	1 1/2	1/8	1 1/2	1 1/2	8.50	500	45*	1 1/2	1/8	1 1/2	1 1/2	10.30	650
12	1 1/2	1/8	1 1/2	1 1/2	8.30	450	46	1 1/2	1/8	1 1/2	1 1/2	9.80	550
13	1 1/2	1/8	1 1/2	1 1/2	8.30	380	47	1 1/2	1/8	1 1/2	1 1/2	9.80	525
14*	1 1/2	1/8	1 1/2	1 1/2	8.30	325	48	1 1/2	1/8	1 1/2	1 1/2	10.30	500
15*	1 1/2	1/8	1 1/2	1 1/2	8.00	285	49*	1 1/2	1/8	1 1/2	1 1/2	9.80	400
16*	1 1/2	1/8	1 1/2	1 1/2	8.00	150	50	1 1/2	1/8	1 1/2	1 1/2	9.50	300
17	1 1/2	1/8	1 1/2	1 1/2	8.00	150	51*	1 1/2	1/8	1 1/2	1 1/2	9.50	270
18*	1 1/2	1/8	1 1/2	1 1/2	8.00	145	52*	1 1/2	1/8	1 1/2	1 1/2	9.50	240
19	1 1/2	1/8	1 1/2	1 1/2	8.00	130	53	1 1/2	1/8	1 1/2	1 1/2	9.50	210
20	2	1	2	2	8.00	110	54*	2	1	2	2	9.50	180
21*	2	1	2	2	8.00	95	55	2	1	2	2	9.50	160
22	2 1/2	1 1/8	2 1/2	2 1/2	8.00	75	56*	2 1/2	1 1/8	2 1/2	2 1/2	9.50	105
23*	2 1/2	1 1/8	2 1/2	2 1/2	8.30	68	57*	2 1/2	1 1/8	2 1/2	2 1/2	9.80	80
24*	2 1/2	1 1/8	2 1/2	2 1/2	8.30	55	58*	2 1/2	1 1/8	2 1/2	2 1/2	9.80	60
25*	2 1/2	1 1/8	2 1/2	2 1/2	8.30	70	59	2 1/2	1 1/8	2 1/2	2 1/2	9.80	60
26	2 1/2	1 1/8	2 1/2	2 1/2	8.30	42	60*	2 1/2	1 1/8	2 1/2	2 1/2	10.00	70
27*	2 1/2	1 1/8	2 1/2	2 1/2	8.30	55	61	2 1/2	1 1/8	2 1/2	2 1/2	10.00	45
28	3	1 1/4	3	3	8.30	32	62	3	1 1/4	3	3	10.50	35
29	3 1/2	1 1/2	3 1/2	3 1/2	8.80	25	63*	3 1/2	1 1/2	3 1/2	3 1/2	10.50	47
30*	2 1/2	1 1/8	2 1/2	2 1/2	9.30	38	64	3 1/2	1 1/2	3 1/2	3 1/2	10.50	30
31	3 1/2	1 1/2	3 1/2	3 1/2	9.30	22	65	3 1/2	1 1/2	3 1/2	3 1/2	11.00	24
32	3 1/2	1 1/2	3 1/2	3 1/2	9.30	20	66*	3 1/2	1 1/2	3 1/2	3 1/2	11.00	25
33*	3 1/2	1 1/2	3 1/2	3 1/2	9.30	26							
34	4	2	4	4	9.30	15							

Those marked * are stock sizes; packed 100 lbs. in a box. Any sizes not enumerated in above list will be charged extra.

MACHINE SCREW NUTS



TAPPED

Order Number.....	67	68	69	70	71	72	73	74	75	76
For Machine Screws, Nos.....	2	3	4	6	8	10	12	14	16	18
Number of Threads to the inch.....	56	48	38	32	32	24	24	20	16	18
Priceper hundred	\$0.65	0.35	0.35	0.35	0.35	0.40	0.45	0.50	0.65	0.85

HEXAGON NUTS, TAPPED

WHITWORTH STANDARD



TAPPED, FACED TOP AND BOTTOM, WITH BLACK SIDES

Order Number.....	77	78	79	80	81	82	83	84	85	86	87	
Size of Hole.....	$\frac{1}{4}$	$\frac{5}{16}$	$\frac{3}{8}$	$\frac{7}{16}$	$\frac{1}{2}$	$\frac{5}{8}$	$\frac{3}{4}$	$\frac{7}{8}$	1	$1\frac{1}{8}$	$1\frac{1}{4}$	inch.
Per hundred.....	\$1.35	1.50	1.60	1.75	2.10	2.75	4.00	5.50	8.00	10.00	14.00	

TAPPED, BRIGHT FINISHED ALL OVER

Order Number.....	88	89	90	91	92	93	94	95	96	97	98	99	100	101
Size of Hole.....	$\frac{1}{4}$	$\frac{5}{16}$	$\frac{3}{8}$	$\frac{7}{16}$	$\frac{1}{2}$	$\frac{5}{8}$	$\frac{3}{4}$	$\frac{7}{8}$	1	$1\frac{1}{8}$	$1\frac{1}{4}$	$1\frac{1}{2}$	$1\frac{3}{4}$	2
Per hundred.....	\$2.45	2.45	2.85	3.00	3.50	4.60	5.85	7.60	10.00	14.40	18.20	23.35	30.30	58.60

CASE HARDENED AND FINISHED

Order Number.....	102	103	104	105	106
Size of Hole.....	$\frac{1}{4}$	$\frac{5}{16}$	$\frac{3}{8}$	$\frac{7}{16}$	$\frac{1}{2}$
Per hundred.....	\$4.20	5.90	8.40	11.30	14.25

When ordering Nuts, please do so by giving the Order Number.

TURNED WASHERS



No. 221

Polished, Champered Edges.

Size of Hole.....	$\frac{1}{4}$	$\frac{5}{16}$	$\frac{3}{8}$	$\frac{7}{16}$	$\frac{1}{2}$	$\frac{5}{8}$	$\frac{3}{4}$	$\frac{7}{8}$	1
Per hundred.....	\$1.50	1.75	2.00	2.25	2.50	3.00	3.50	4.00	4.50

IRON WASHERS MANUFACTURERS' STANDARD LIST

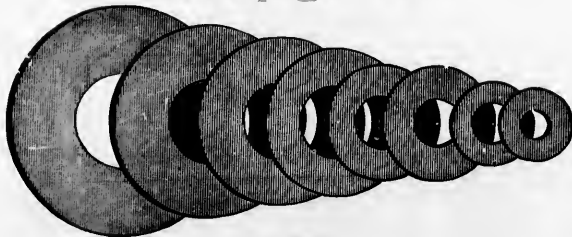

No. 220

Size of Hole.....	$\frac{3}{16}$	$\frac{1}{4}$	$\frac{5}{16}$	$\frac{3}{8}$	$\frac{7}{16}$	$\frac{1}{2}$	$\frac{9}{16}$	$\frac{5}{8}$	$1\frac{1}{16}$	$\frac{3}{4}$	$1\frac{1}{8}$	$\frac{7}{8}$	$1\frac{1}{16}$	$1\frac{1}{8}$	$1\frac{1}{4}$	$1\frac{3}{8}$	inch.
Diameter.....	$\frac{7}{8}$	$\frac{1}{2}$	$\frac{8}{16}$	$\frac{7}{8}$	1	$1\frac{1}{8}$	$1\frac{1}{4}$	$1\frac{1}{2}$	$1\frac{3}{4}$	2	$2\frac{1}{2}$	3	$3\frac{1}{2}$	$4\frac{1}{2}$	$5\frac{1}{2}$	$6\frac{1}{2}$	"
Thickness..... Gauge No.	18	18	16	14	14	13	12	12	10	10	9	9	9	9	9	9	"
Size of Bolt.....	$\frac{1}{8}$	$\frac{1}{4}$	$\frac{1}{2}$	$\frac{3}{8}$	$\frac{1}{2}$	$\frac{5}{8}$	$\frac{3}{4}$	$\frac{7}{8}$	1	$1\frac{1}{8}$	$1\frac{1}{4}$	$1\frac{1}{2}$	$1\frac{3}{4}$	$1\frac{1}{2}$	$1\frac{3}{4}$	$1\frac{1}{2}$	"
Per lb.....	\$0.20	0.18	0.15	0.13	0.10	0.10	0.09	0.09	0.08	0.08	0.08	0.08	0.08	0.08	0.08	0.08	

Price per 100 lbs.	Average Number in 100 lbs.
120.00	8700
16.00	4200
13.00	2600
12.00	2280
11.20	1590
11.20	1700
11.20	1450
10.50	1100
10.50	1220
10.30	700
10.30	650
9.80	550
9.80	525
10.30	500
9.80	400
9.50	300
9.50	270
9.50	240
9.50	210
9.50	180
9.50	160
9.50	105
9.80	80
9.80	90
9.80	60
10.00	70
10.00	45
10.50	35
10.50	47
10.50	30
11.00	24
11.00	25

above list will

75	76
16	18
16	18
0.65	0.85

WASHERS AND RIVETS

LOCK WASHERS



No. 222

Size of Bolt	¼	⅝	¾	7/16	½	⅝	¾	inch.
Per 100.....	\$1.65	1.75	2.00	2.25	2.50	2.75	3.00	
Size of Bolt	¾	1	1½	1¾	1½	2	inch.	
Per 100.....	\$3.25	4.15	5.00	6.25	10.00	15.00	20.00	

CAST IRON WASHERS



No. 223

Size of Bolt...	¾	1	1½	1¾	2	inch.
Per lb.....	\$0.06	0.06	0.05	0.05	0.05	
Size.....	1	1½	1¾	1½	2	inch.
Per lb.....	\$0.05	0.05	0.05	0.05	0.05	

IRON RIVETS IN BULK

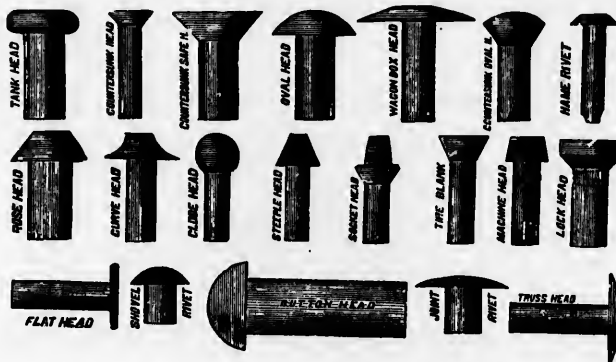

LIST FOR ROUND, FLAT, WAGGON BOX, TRUSS OR OTHER STYLE HEADS, IN QUANTITIES

Price per Pound

DIAMETER.	LENGTH.													
	½ and longer	15/16	7/16	13/16	¾	11/16	5/8	9/16	¼	7/16	3/8	5/16	1/8	3/16
1/16 inch.....	11½	11½	11½
1/8 ".....	12	12	12
3/16 ".....	12	12	12
1/4 ".....	12½	12½	12½	13	13
No. 1.....	12½	12½	12½	13	13	13	13	14	15	15	15	16	16
" 2.....	12½	12½	12½	13	13	13	13	14	15	15	15	16	16
" 3.....	13	13	13	14	14	14	14	15	15	15	15	16	16
1/2 inch.....	13	13	13	14	14	14	14	15	15	15	15	16	16
No. 4.....	13	13	13	14	14	14	14	15	15	15	15	16	16
" 5.....	14	14	14	15	15	15	15	16	16	16	16	17	17
" 6.....	14	14	14	15	15	15	15	16	16	16	16	17	17
3/4 inch.....	14	14	14	15	15	15	15	16	16	16	16	17	17
No. 7.....	14	14	14	15	15	15	15	16	16	16	16	17	17
" 8.....	15	15	15	16	16	16	16	17	17	17	17	18	18
" 9.....	16	16	16	17	17	17	17	18	18	18	18	19	19
" 10.....	18	18	18	19	19	19	19	20	20	20	20	21	21
" 11.....	19	19	19	20	20	20	20	21	21	21	21	22	22
" 12.....	20	20	20	21	21	21	21	22	22	22	22	23	23
" 13.....	21	21	21	22	22	22	22	23	23	23	23	24	24
" 14.....	25	25	25	26	26	26	26	27	27	27	27	28	28
	27	27	27	28	28	28	28	29	29	29	29	30	30
	30	30	30	31	31	31	31	32	32	32	32	33	33
	35	35	35	36	36	36	36	37	37	37	37	38	38
	38	38	38	39	39	39	39	40	40	40	40	41	41
	40	40	40	41	41	41	41	42	42	42	42	43	43
	45	45	45	46	46	46	46	47	47	47	47	48	48
	50	50	50	51	51	51	51	52	52	52	52	53	53
	52	52	52	53	53	53	53	54	54	54	54	55	55
	55	55	55	56	56	56	56	57	57	57	57	58	58
	58	58	58	59	59	59	59	60	60	60	60	61	61
	60	60	60	61	61	61	61	62	62	62	62	63	63
	65	65	65	66	66	66	66	67	67	67	67	68	68

Rivets made from wire smaller than No. 14, all lengths, 70 cents per pound.

Tinning..... per pound extra \$0.09

We
Blac
Tin

We
Blac
Tin

Nos.
Leng
Dian
Price

BOILER, BRIDGE AND SHIP RIVETS

STANDARD HEADS



$\frac{3}{4}$ inch.
 0.05
 $\frac{1}{2}$ inch.
 0.05

Prices will be quoted on application

BLACK AND TINNED IRON RIVETS

FLAT HEADS

Put up in packages of 1000 each.

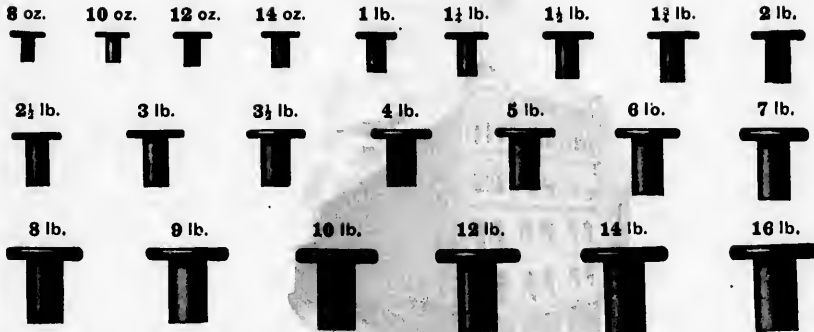

Weight.....		8	10	12	14 oz.	1	1 1/2	1 1/2	1 3/4	2	2 1/2	3 lbs.
Black.....	per thousand	\$0.20	0.22	0.24	0.26	0.27	0.29	0.32	0.36	0.40	0.47	0.53
Tinned.....	"	0.24	0.25	0.28	0.30	0.33	0.37	0.41	0.47	0.52	0.63	0.72
Weight.....		3 1/2	4	5	6	7	8	9	10	12	14	16 lbs.
Black.....	per thousand	\$0.58	0.64	0.75	0.90	1.05	1.20	1.27	1.40	1.70	1.90	2.25
Tinned.....	"	0.80	0.88	1.05	1.26	1.50	1.70	1.80	2.00	2.40	2.75	3.10

COOPERS' RIVETS

FLAT HEAD

In bulk.

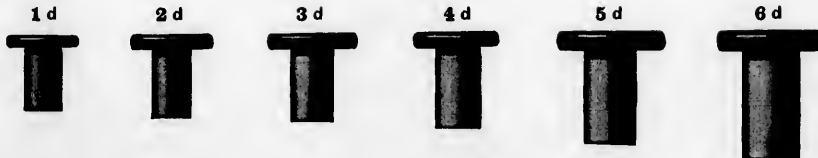

Nos.....		1 d	2 d	3 d	4 d	5 d	6 d
Length.....		$\frac{1}{2}$	$\frac{3}{4}$	$\frac{1}{2}$	$\frac{1}{2}$	$\frac{1}{2}$	$\frac{1}{2}$ inch.
Diameter.....		$\frac{1}{4}$ W.G.	$\frac{1}{4}$ W.G.	$\frac{3}{8}$ W.G.	$\frac{3}{8}$ W.G.	$\frac{1}{2}$ W.G.	$\frac{1}{2}$
Price.....	per lb.	\$0.13	0.13	0.12 1/2	0.12 1/2	0.12	0.12

QUANTITIES

$\frac{3}{32}$	$\frac{1}{8}$	$\frac{5}{32}$
18	20	21
23	24	25
23	24	25
23	24	25
23	24	25
27	29	30
35	37	38
40	42	45
45	50	55
50	55	60
60	63	65

and extra \$0.08

COTTER PINS

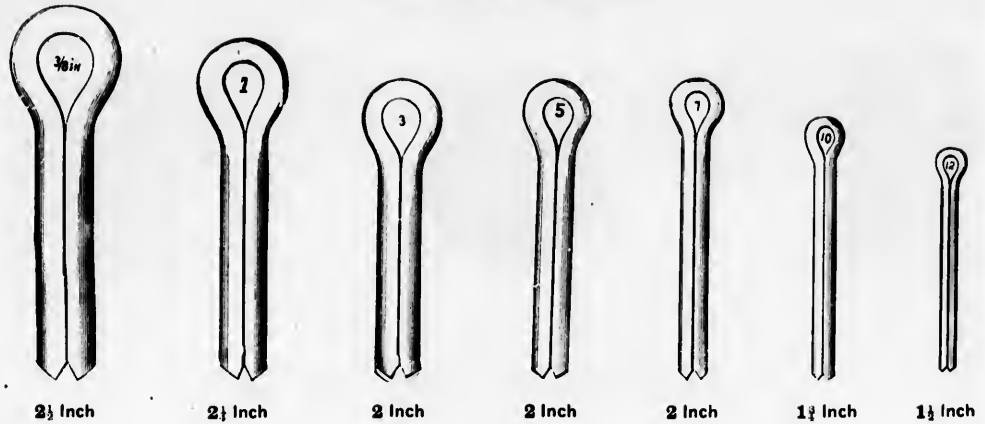

Price per Gross

NUMBERS.	3/16	1	2	3	4	5	6	7	8	9	10	11	12
Length, 1 inch.....									\$0.28	\$0.27	\$0.25	\$0.24	\$0.22
" 1 1/2 ".....								\$0.33	0.30	0.28	0.27	0.25	0.24
" 1 1/4 ".....		\$0.80	\$0.73	\$0.67	\$0.58	\$0.50	\$0.42	0.37	0.33	0.32	0.30	0.28	0.27
" 1 1/2 ".....		0.90	0.80	0.73	0.65	0.55	0.45	0.40	0.37	0.35	0.33	0.32	0.30
" 2 ".....		1.00	0.90	0.80	0.70	0.60	0.48	0.44	0.40	0.38	0.37	0.35	0.33
" 2 1/2 ".....		1.10	1.00	0.87	0.75	0.65	0.53	0.47	0.44	0.42	0.40	0.38	0.37
" 3 ".....	\$2.20	1.20	1.10	0.93	0.80	0.70	0.58	0.50	0.47	0.45	0.44	0.42	0.40
" 3 1/2 ".....	2.47	1.40	1.30	1.10	0.93	0.80	0.68	0.60	0.55	0.52	0.50	0.48	0.47
" 3 1/4 ".....	2.73	1.60	1.50	1.30	1.10	0.93	0.78	0.70	0.65	0.60	0.57	0.55	0.53

THRESHING MACHINE TEETH

Drop Forged from Best Soft Steel.



No. 1



No. 2



No. 3

Prices and all particulars on application.

AXLE WASHERS



NUT AND COLLAR WASHERS

LEATHER

FOR NUT

Nos.....	2	15	28	41	55	81	134
Size.....	$\frac{3}{4}$	$\frac{7}{8}$	$1\frac{1}{8}$	1	$1\frac{1}{4}$	$1\frac{1}{2}$	$1\frac{3}{4}$ inch.
Per 100....	\$1.75	1.75	1.75	1.75	2.25	2.50	2.75

FOR COLLAR

Nos.....	42	68	69	94	121	147	188
Size.....	$\frac{3}{4}$	$\frac{7}{8}$	$1\frac{1}{8}$	1	$1\frac{1}{4}$	$1\frac{1}{2}$	$1\frac{3}{4}$ inch.
Per 100....	\$2.25	2.25	2.50	2.50	2.50	2.75	3.50

VULCANIZED

FOR NUT

Nos.....	2	15	28	41	55	81	134
Size.....	$\frac{3}{4}$	$\frac{7}{8}$	$1\frac{1}{8}$	1	$1\frac{1}{4}$	$1\frac{1}{2}$	$1\frac{3}{4}$ inch.
Per 100....	\$1.75	1.75	1.75	1.75	2.25	2.50	2.75

FOR COLLAR

Nos.....	42	68	69	94	121	147	188
Size.....	$\frac{3}{4}$	$\frac{7}{8}$	$1\frac{1}{8}$	1	$1\frac{1}{4}$	$1\frac{1}{2}$	$1\frac{3}{4}$ inch.
Per 100....	\$2.25	2.25	2.50	2.50	2.50	2.75	3.50

50 in a box.

AXLE GREASE

No. 1—Butler's "X L" Axle Grease, Dark.....	per gross	\$10.00
" 2— " "X X" " " Light.....	"	10.50
" 3—Royal " " Dark.....	"	10.50
" 4— " " " Light.....	"	11.00
" 5—Peerless " ".....	"	13.00

ANTI-RATTLERS

JOHNSON'S
Pat.: U. S. A., Feb. 27, '94
Canada, March 13, '95.

DANDY



WIRE



SEE THAT
Wear Plate



No. 1—Dandy Anti-Rattlers, Cast Steel.....	per gross pairs	\$12.00
" 2—Johnson's " " No. 1 for Axles $\frac{1}{2}$, 1 and $1\frac{1}{4}$ inch.....	" "	16.00
" 3—Wire " ".....	" "	6.00

One dozen pair in a box.



$1\frac{1}{2}$ Inch

10	11	12
0.25	\$0.24	\$0.22
0.27	0.25	0.24
0.30	0.28	0.27
0.33	0.32	0.30
0.37	0.35	0.33
0.40	0.38	0.37
0.44	0.42	0.40
0.50	0.48	0.47
0.57	0.55	0.53



No. 3

AXLE CLIPS

BUGGY CLIPS



Norway Iron, Bevelled Edges, $\frac{1}{8}$ inch End, $\frac{1}{2}$ inch wide.

Nos.	00	0	1	2	3	4	5	6
Length of Flat Part	2 $\frac{1}{2}$	2 $\frac{3}{4}$	3 $\frac{1}{4}$	3 $\frac{3}{4}$	4 $\frac{1}{4}$	4 $\frac{3}{4}$	5 $\frac{1}{4}$	0 inch.
Per dozen	\$0.70	0.70	0.70	0.75	0.78	0.97	1.20	1.50

Four dozen in a box.

CUTTER CLIPS



Norway Iron, $\frac{1}{4}$ inch End, $\frac{1}{2}$ inch wide.

Nos.	0	1	2	3
Length of Flat Part	2	2 $\frac{1}{4}$	3	3 $\frac{1}{4}$ inch.
Per dozen	\$1.00	1.00	1.00	1.00

Four dozen in a box.

SPRING BAR CLIPS



Norway Iron, $\frac{1}{8}$ inch End, $\frac{1}{2}$ inch wide.

Nos.	0	1	2	3	4	5	6
Length of Centre	4 $\frac{1}{4}$	4 $\frac{3}{4}$	5 $\frac{1}{4}$	5 $\frac{3}{4}$	6 $\frac{1}{4}$	7	7 $\frac{3}{4}$ inch.
Per dozen	\$1.00	1.15	1.22	1.30	1.40	1.65	1.85

Four dozen in a box.

CLIP YOKES



For Axles $\frac{1}{2}$ to $1\frac{1}{2}$ inch.

$\frac{1}{8}$ inch Holes	per lb.	\$0.12
10 lbs. in a box.		

FELLOE PLATES



Sizes $\frac{1}{2}$ to 2 inch.

Per lb.	\$0.10
5 lbs. in a box.	

CLIPS

CLIP KING BOLTS Finished.



Nos.....	1	2	3	4
Size at Collar.....	$\frac{1}{4}$	$\frac{7}{8}$	$\frac{1}{2}$	$\frac{1}{2}$ inch.
Per dozen.....	\$4.00	4.00	4.50	5.00

HALF ROUND BUGGY SADDLE CLIPS Made from Norway Iron.

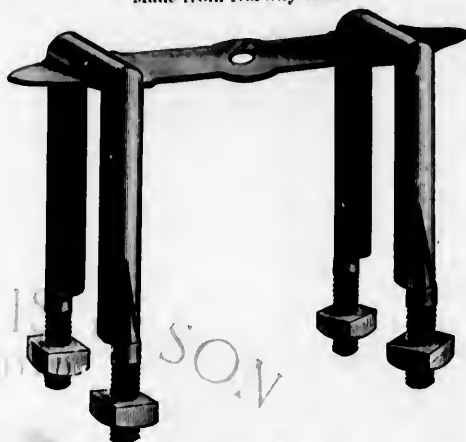

SHAFT COUPLINGS Finished.

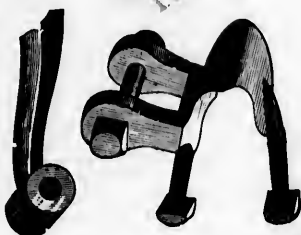

LIGHT

Size.....	$\frac{7}{8}$	1 inch.
Per dozen pairs.....	\$8.00	8.00

HEAVY

Size.....	1	1 $\frac{1}{4}$	1 $\frac{1}{2}$	1 $\frac{3}{4}$ inch.
Per dozen pairs.....	\$9.00	10.00	11.00	12.00

POLE EYES



BLACK

Size.....	$\frac{7}{8}$	1	1 $\frac{1}{8}$	1 $\frac{1}{4}$ inch.
Per dozen pairs....	\$6.50	6.50	6.50	8.00

In ordering say whether $\frac{3}{8}$ or $\frac{7}{8}$ hole.

LONG DROP BODY LOOPS

Drop.....inch	5	5 $\frac{1}{2}$	6	6 $\frac{1}{2}$	7
Per set, $\frac{3}{4}$ inch bolt	\$1.00	1.00	1.00	1.00	1.00



SINGLE LIP BODY LOOPS

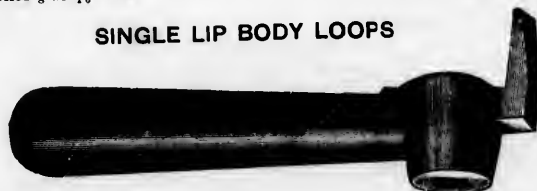

No. 2—For $\frac{3}{4}$ inch Bolt.....per doz. \$1.00

6
6 inch.
1.50

3
3 $\frac{1}{2}$ inch.
1.00

6
7 $\frac{1}{2}$ inch.
1.85

8
\$0.10

CARRIAGE STEP PADS

WROUGHT IRON



SQUARE PATTERN

No. 1-3 x 3½ inch... per doz. pairs \$3.15
 " 2-4 x 4½ " " " " 3.50
 " 3-4½ x 4 " " " " 4.40



STEP SHANKS

Not Drilled.
 Per dozen pairs.... \$2.00



ROUND PATTERN

5 inch..... per doz. pairs \$4.40

SLEIGH KNEE BRACES



Sizes ½, ¾ and 1 inch between holes..... per single doz. 1.00

OFF SETS



Sizes ¾ inch..... per doz. pieces 1.00
 " 1 " " " 1.10

MALLEABLE IRONS

SINGLE TREE HOOKS



No. 120, IN PAIRS, RIGHT AND LEFT

No. 120	A	B	C	E
Diam. Ferrule inside small end	1	1½	1¾	1¾ inch.
Per lb.	\$.....			



No. 130

No. 130—Diam. Ferrule inside small end	1¾ inch.
Per lb.	\$.....

WHIFFLETREE FERRULES



No. 5, CLOSED END

No. 5	A	B	C	D
Diam. inside large end	¾	1	1	1½ inch.
Per lb.	\$.....			



No. 160, WITH RINGS

No. 160	A	B	C	D
Diam. Ferrule	1¾	1½	1¾	1¾ inch.
Rings	1¾	1¾	1¾	2 "
Per lb.	\$.....			

WHIFFLETREE COUPLINGS

In Pairs.



No. 690

No. 690—High Pattern	B
Width	1½ inch.
Length	3½ "
Bolt	¾ "
Per lb.	\$.....



No. 695

No. 695	A	C	E	G
Width	1¾	1¾	2¼	2¼ inch.
Length	3¾	4¾	5¼	5¼ "
Bolt	¾	¾	1	1 "
Per lb.	\$.....			

SINGLE TREE TONGUES



No. 35

No. 35	A	B
Shank	¾	¾ inch.
Length	2¾	3½ "
Per lb.	\$.....	



No. 70

No. 70	A	B
Shank	¾	¾ inch.
Length	3	3½ "
Per lb.	\$.....	



No. 75

No. 75	A	B
Shank	¾	¾ inch.
Length	3½	4 "
Per lb.	\$.....	



PATTERN

per doz. pairs \$4.40

single doz. 1.00

oz. pieces 1.00
" 1.10

MALLEABLE IRONS

WHIFFLETREE CENTRE IRONS



No. 182

No.....	182	
Round Whiffletree.....	$1\frac{1}{2}$ inch.	
Length.....	4 "	
Per lb.....	\$....	



No. 190

No. 190.....	A	B
Oval Whiffletree.....	$2\frac{3}{8} \times 1\frac{1}{2}$	$2\frac{1}{2} \times 1\frac{1}{2}$ inch.
Width.....	$2\frac{1}{2}$	$2\frac{3}{8}$ "
Length.....	$4\frac{1}{2}$	$4\frac{1}{2}$ "
Per lb.....	\$....	\$....

NECK YOKE FERRULES



No. 180

Oval Ring in Eye, Solid Loop.

No.....	180	
Diameter.....	$1\frac{1}{2}$ inch.	
Per lb.....	\$....	

NECK YOKE SPREADER CLEAVES



No. 183

2 Holes.

No. 183.....	A	B
Width inside.....	$1\frac{1}{2}$	$1\frac{1}{2}$ inch.
Length.....	$3\frac{3}{8}$	$4\frac{1}{2}$ "
Per lb.....	\$....	\$....

END CLEAVES



No. 2806

No.....	2806	
Inside Width.....	$\frac{2}{3}$ inch.	
Entire Length.....	$\frac{4}{3}$ "	
Per lb.....	\$....	



No. 2820

No.....	2820	
Inside Width.....	$\frac{2}{3}$ inch.	
Entire Length.....	4 "	
Per lb.....	\$....	

DOUBLE TREE CLEAVES



No. 480

No.....	480	
Inside Width.....	2 inch.	
Entire Length.....	$4\frac{1}{2}$ "	
Per lb.....	\$....	

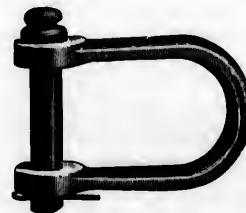

No. 380

No.....	380	
Inside Width.....	$1\frac{1}{2}$ inch.	
Entire Length.....	4 "	
Per lb.....	\$....	

MALLEABLE IRONS

THUMB NUTS



No. 1405

No. 1405	AA	A	B	C	
Hole.....	$\frac{1}{8}$	$\frac{1}{4}$	$\frac{3}{8}$	$\frac{1}{2}$	inch.
Per lb.....	\$....				

Holes Cored Straight.

BOX ROD NUTS



No. 1490

No. 1490	B	
Hole.....	$\frac{1}{2}$	inch.
Length.....	$4\frac{1}{2}$	"
Per lb.....	\$....	

B
2 1/2 x 1 1/2 inch.
2 3/4 " "
4 1/2 " "

LEEVISES

CHECK LOOPS



No. 2000



No. 2005

No. 2000	B	D	E	F	2005B	
Loop.....	1	1 1/2	1 1/2	1 3/4	2 3/4	inch.
Length.....	2 1/2	2 3/4	3	3 1/2	4 1/2	"
Per lb.....						\$....

B
1 1/2 inch.
4 1/2 " "

CARRIAGE WRENCHES

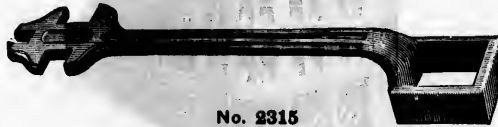

No. 2315

No. 2315	C	D	E	F	G	
Axle Nut.....	1	1 1/2	1 1/2	1 3/4	1 1/2	inch.
Opening.....	1 1/2	1 3/4	1 3/4	1 3/4	1 3/4	"
Length.....	9 1/2	10 1/2	10	10 1/2	10 1/2	"
Per lb.....						\$....

2820
4 inch.
4 " "

S WRENCHES



No. 2340

No. 2340	C	A	
Openings	$\frac{1}{8}$ $\frac{1}{4}$ and $\frac{3}{8}$ 1	$\frac{1}{2}$ $\frac{3}{4}$ and 1 1 1/2	inch.
Length.....	9	11	"
Per lb.....			\$....

380
1 1/2 inch.
4 " "

HORSE SHOES



No. 3, FRONT
(MEDIUM)

Full Size.

Made in all sizes from Nos. 0 to 7 inclusive.

Weights of Iron Horse Shoes

Nos.	0	1	2	3	4	5	6	7	
Medium, Front	13	17	20	25	28	36	39	46	ounces each.
Light "	12	14½	17½	21	25	29½	38	42	"
Snow "	..	12	14	17	21	25	28	..	"
Medium, Hind	11	13	17	21	25	28	33	38	"
Light "	10	12	15	18	21	25	31	34	"
Snow "	..	11	12	15	18	20	24	..	"

Weights of Steel Horse Shoes

Nos.	0	1	2	3	4	5	
Light, Front	..	12½	16	18½	23½	27½	ounces each.
Featherweight, Front	10	12	14	17	22	25	"
Light, Hind	..	10½	13½	16½	20	25	"
Featherweight, Hind	8	9	10	12	15	19	"

HORSE SHOES

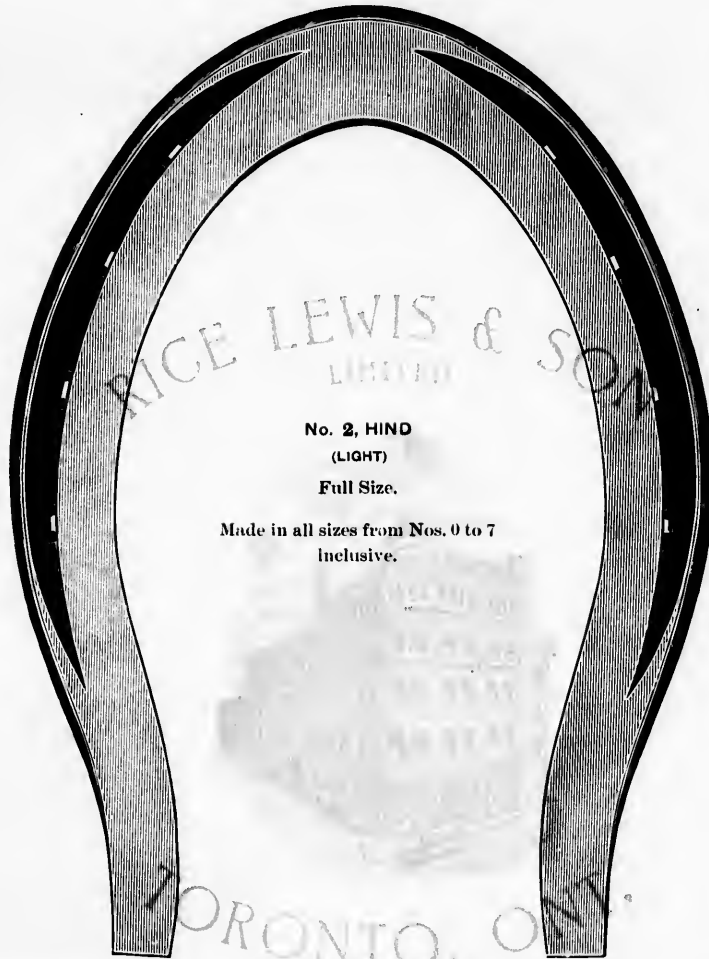

No. 2, HIND
(LIGHT)
Full Size.

Made in all sizes from Nos. 0 to 7
inclusive.

IRON HORSE SHOES

Light, Medium or Heavy Patterns per 100 lbs. \$....
Winter or Snow Shoes, 25c. per 100 lbs. extra.

STEEL HORSE SHOES

Light, Nos. 1, 2, 3, 4 and 5 per 100 lbs.
Featherweight, Nos. 0, 1 and 2 "
" Nos. 3, 4 and 5 "
" Assorted, Nos. 0 to 5 "

"TOE WEIGHT" STEEL HORSE SHOES

Nos.	1	2	3	4	
Average Weight.....each	11	14	17	20	ounces.
Per keg, 100 lbs.....	\$....	

In kegs of 100 lbs.

When ordering please state pattern required and if "All Front" or "All Hind" or "Assorted."

TOE CALKS



SHARP CALKS

Nos.	0	1	2	3	4	5		
Length.....	1½	1¾	2	2¼	2½	2¾	inch.	
Sizes.....	1½ x ¾	1¾ x ¾	2 x ¾	2¼ x ¾	2½ x 1	2¾ x 1	"	
Number to the pound.....	20	17	9	7	5	4		
Price, 25 lbs. in bulk, or 24 lbs. in 4 lb. packages.....							per box	\$2.50

BLUNT CALKS

Nos.	0	1	2	3	4	5	6	7		
Length.....	1½	1¾	2	2¼	2½	2¾	3	3	inch.	
Sizes.....	1½ x 1	1¾ x 1	2 x 1	2¼ x 1	2½ x 1	2¾ x 1	3 x 1	3 x 1	"	
Number to the pound.....	21	16	10	8	6	5	4	3		
Price, 25 lbs. in bulk, or 24 lbs. in 4 lb. packages.....									per box	\$2.00

HORSE SHOE NAILS

Pointed and Finished, made from best Norway Iron.



"C." BRAND

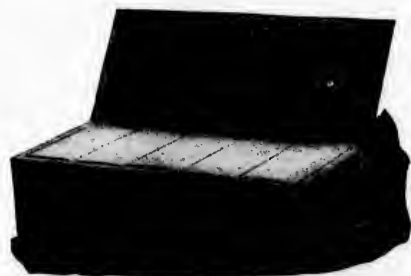

"P. B." BRAND



OVAL HEAD



COUNTERSUNK HEAD

Size Nos.	1	2	3	4	5	6	7	8	9	10	11	12	14
Lengths.....	1½	1¾	2	2¼	2½	2¾	3	3¼	3½	3¾	4	4¼	4½
Price per pound.....	\$3.00	2.00	1.00	0.50	0.30	0.27	0.24	0.23	0.22	0.22	0.22	0.22	0.22

Nos. 1 to 3 in 1 lb. papers, Nos. 4 to 14 in 5 lb. papers, in boxes of 25 lbs. each.

Extra for 1 lb. packages :—½ cent per lb. net

IRON WOOD SCREWS

DISCOUNT PRICE LIST

List of January 1, 1891.

Price per Gross

SIZE.		DISCOUNT.						SIZE.		DISCOUNT.						SIZE.		DISCOUNT.																																																																																																																																																																																																																																																																																																																																																																																																																																																																																																																																																																																																																																																																																																																																																																																																																																																																																																																																																																																																																																																																																																																																																																																																																																																																																																																																																																																																													
Inch.	No.	Last Price	50	55	60	65	70	75	Inch.	No.	Last Price	50	55	60	65	70	75	Inch.	No.	Last Price	50	55	60	65	70	75	Inch.	No.	Last Price	50	55	60	65	70	75																																																																																																																																																																																																																																																																																																																																																																																																																																																																																																																																																																																																																																																																																																																																																																																																																																																																																																																																																																																																																																																																																																																																																																																																																																																																																																																																																																																												
1	0	40	20	18	16	14	12	10	1	11	100	50	45	40	35	30	25	2	15	235	118	103	94	83	71	59	3	16	200	130	117	104	91	78	65	4	17	280	140	123	112	98	84	70	5	18	305	153	138	122	107	92	77	6	20	300	180	162	144	120	108	90	7	22	420	210	180	168	147	120	105	8	24	480	240	210	192	168	144	120																																																																																																																																																																																																																																																																																																																																																																																																																																																																																																																																																																																																																																																																																																																																																																																																																																																																																																																																																																																																																																																																																																																																																																																																																																																																																																																																															
	1	40	20	18	16	14	12	10		12	110	55	50	44	38	33	28		16	13	125	63	57	50	44	38		32	17	14	12	10	14	140	70		63	50	40	32	35	35	30	25		18	16	14	12	10	15	100	80		72	64	56	48	40	30	25	16		180	90	81	72	63	54	45	35		30	25	17	200	100	90	80	70	60	50	40	30	25	18	220	110	100	88	77	66	55	45	35	30	25	19	270	135	122	108	95	81	68	55	45	35	30	25	19	7	80	40	36	32	28	24	20	15	8	87	44	40	35	31	27	22	17	9	94	47	43	38	33	29	24	19	10	100	50	45	40	35	30	25	20	110	55	50	44	38	33	28	23	12	120	60	54	48	42	36	30	24	13	135	68	61	54	48	41	34	28	14	155	78	70	62	55	47	39	31	15	175	88	79	70	62	53	44	36	16	195	98	88	78	68	59	49	40	17	215	108	97	86	76	65	54	44	18	235	118	100	94	83	71	59	47	19	285	143	120	114	100	86	72	58	48	38	33	29	24	20	15	110	55	50	44	38	33	28	23	16	130	65	59	52	46	40	33	26	17	150	75	68	60	53	45	38	30	18	170	85	77	68	60	51	43	35	19	190	95	86	76	67	57	48	40	20	210	105	95	84	74	63	53	44	21	230	115	104	92	81	69	58	48	22	250	125	113	100	88	75	63	53	23	300	150	135	120	105	90	75	63	24	4	41	21	19	17	15	13	11	5	46	23	21	19	17	14	12	10	6	53	27	24	22	19	16	14	11	7	60	30	27	24	21	18	15	12	8	67	34	31	27	24	21	17	14	9	74	37	34	30	26	23	20	17	10	81	41	37	33	29	25	21	18	11	88	44	40	36	31	27	22	19	12	95	48	43	38	34	29	24	20	13	105	53	48	42	37	32	27	23	14	120	60	54	48	42	36	30	24	15	135	68	61	54	48	41	34	28	16	155	78	70	62	55	47	39	31	16	5	52	26	24	21	19	16	13	7	50	30	27	24	21	18	15	12	8	66	33	30	27	24	20	17	14	9	73	37	33	30	26	22	19	16	12	80	40	36	32	28	24	20	17	13	87	44	40	35	31	27	22	19	14	94	47	43	39	33	29	24	20	15	100	50	45	40	35	30	25	20	16	115	58	52	46	41	35	29	24	17	130	65	59	52	46	39	33	28	18	150	75	68	60	53	45	38	30	19	170	85	77	68	60	51	43	35	20	5	50	30	27	24	21	18	15	12	7	66	33	30	27	24	20	17	14	9	73	37	33	30	26	22	19	16	12	80	40	36	32	28	24	20	17	13	87	44	40	35	31	27	22	19	14	94	47	43	39	33	29	24	20	15	100	50	45	40	35	30	25	20	16	115	58	52	46	41	35	29	24	17	130	65	59	52	46	39	33	28	18	150	75	68	60	53	45	38	30	19	170	85	77	68	60	51	43	35	20	5	50	30	27	24	21	18	15	12	7	66	33	30	27	24	20	17	14	9	73	37	33	30	26	22	19	16	12	80	40	36	32	28	24	20	17	13	87	44	40	35	31	27	22	19	14	94	47	43	39	33	29	24	20	15	100	50	45	40	35	30	25	20	16	115	58	52	46	41	35	29	24	17	130	65	59	52	46	39	33	28	18	150	75	68	60	53	45	38	30	19	170	85	77	68	60	51	43	35	20	5	50	30	27	24	21	18	15	12	7	66	33	30	27	24	20	17	14	9	73	37	33	30	26	22	19	16	12	80	40	36	32	28	24	20	17	13	87	44	40	35	31	27	22	19	14	94	47	43	39	33	29	24	20	15	100	50	45	40	35	30	25	20	16	115	58	52	46	41	35	29	24	17	130	65	59	52	46	39	33	28	18	150	75	68	60	53	45	38	30	19	170	85	77	68	60	51	43	35	20	5	50	30	27	24	21	18	15	12	7	66	33	30	27	24	20	17	14	9	73	37	33	30	26	22	19	16	12	80	40	36	32	28	24	20	17	13	87	44	40	35	31	27	22	19	14	94	47	43	39	33	29	24	20	15	100	50	45	40	35	30	25	20	16	115	58	52	46	41	35	29	24	17	130	65	59	52	46	39	33	28	18	150	75	68	60	53	45	38	30	19	170	85	77	68	60	51	43	35	20	5	50	30	27	24	21	18	15	12	7	66	33	30	27	24	20	17	14	9	73	37	33	30	26	22	19	16	12	80	40	36	32	28	24	20	17	13	87	44	40	35	31	27	22	19	14	94	47	43	39	33	29	24	20	15	100	50	45	40	35	30	25	20	16	115	58	52	46	41	35	29	24	17	130	65	59	52	46	39	33	28	18	150	75	68	60	53	45	38	30	19	170	85	77	68	60	51	43	35	20	5	50	30	27	24	21	18	15	12	7	66	33	30	27	24	20	17	14	9	73	37	33	30	26	22	19	16	12	80	40	36	32	28	24	20	17	13	87	44	40	35	31	27	22	19	14	94	47	43	39	33	29	24	20	15	100	50	45	40	35	30	25	20	16	115	58	52	46	41	35	29	24	17	130	65	59	52	46	39	33	28	18	150	75	68	60	53	45	38	30	19	170	85	77	68	60	51	43	35	20	5	50	30	27	24	21	18	15	12	7	66	33	30	27	24	20	17	14	9	73	37	33	30	26	22	19	16	12	80	40	36	32	28	24	20	17	13	87	44	40	35	31	27	22	19	14	94	47	43	39	33	29	24	20	15	100	50	45	40	35	30	25	20	16	115	58	52	46	41	35	29	24	17	130	65	59	52	46	39	33	28	18	150	75	68	60	53	45	38	30	19	170	85	77	68	60	51	43	35	20	5	50	30	27	24	21	18	15	12	7	66	33	30	27	24	20	17	14	9	73	37	33	30	26	22	19	16	12	80	40	36	32	28	24	20	17	13	87	44	40	35	31	27	22	19	14	94	47	43	39	33	29	24	20	15	100	50	45	40	35	30	25	20	16	115	58	52	46	41	35	29	24	17	130	65	59	52	46	39	33	28	18	150	75	68	60	53	45	38	30	19	170	85	77	68	60	51	43	35	20	5	50	30	27	24	21	18	15	12	7	66	33	30	27	24	20	17	14	9	73	37	33	30	26	22	19	16	12	80	40	36	32	28	24	20

Adopted May 1, 1867.

CUT TACKS



B.B.B. CUT TACKS

Full Half Weight.

Ounces.....	1	1 1/2	2	2 1/2	3	4	6	8	10	12	14	16	18	20	22	24
Blued.....per doz.	\$0.48	0.53	0.58	0.63	0.68	0.73	0.78	0.83	0.88	1.03	1.18	1.33	1.48	1.63	1.78	1.93
" in bulk.....per lb.	1.15	0.98	0.77	0.66	0.58	0.49	0.40	0.31	0.20	0.28	0.27	0.20	0.20	0.20	0.20	0.20

One dozen papers in a package; bulk, 25 lbs. in a box.

SWEDES IRON, MINERS' AND UPHOLSTERERS' TACKS

Full Half Weight.

Ounces.....	1	1 1/2	2	2 1/2	3	4	6	8	10	12	14	16	18	20	22	24
Blued.....per doz.	\$0.53	0.58	0.63	0.68	0.73	0.83	0.93	1.03	1.13	1.30	1.48	1.65	1.88	2.00	2.20	2.40
Tinned....."	0.78	0.83	0.88	0.93	1.00	1.10	1.20	1.30	1.48	1.70	1.93	2.15	2.40	2.68	2.95	3.23
Blued, in bulk.....per lb.	1.15	0.98	0.77	0.66	0.58	0.49	0.40	0.31	0.20	0.28	0.27	0.20	0.20	0.20	0.20	0.20

One dozen papers in a package; bulk, 25 lbs. in a box.

TINNED TACKS

(All kinds, excepting Gimp and Lace.)

Ounces.....	1	1 1/2	2	2 1/2	3	4	6	8	10	12	14	16	18	20	22	24
In bulk.....per lb.	\$1.58	1.33	1.13	0.95	0.80	0.65	0.53	0.41	0.30	0.38	0.37	0.35	0.35	0.35	0.35	0.35

25 lbs. in a box.

Zinc Tacks, in 1 lb. papers, all sizes.....per lb. \$0.30

CARPET TACKS



Large Head. Full Half Weight.

Ounces.....	4	6	8	10	12	14	16
B.B.B. Iron, Blued.....per doz.	\$0.73	0.78	0.83	0.88	1.03	1.18	1.33
" " Tinned....."	0.98	1.05	1.13	1.25	1.43	1.65	1.88
Leathered, 100 to paper....."	0.00	0.00	0.00	0.64	0.68
B.B.B. Iron, Blued, in bulk.....per lb.	0.49	0.40	0.31	0.20	0.28	0.27	0.20

One dozen papers in a package; bulk, 25 lbs. in a box.

GIMP AND LACE TACKS

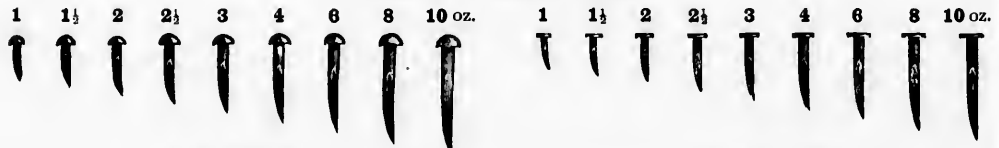

GIMP TACKS

Full Half Weight.

Swedes Iron.

LACE TACKS

Ounces.....	1	1 1/2	2	2 1/2	3	4	6	8	10	12
Blued.....per doz.	\$0.88	0.95	1.03	1.10	1.20	1.30	1.43	1.55	1.70	1.88
Tinned....."	1.13	1.20	1.28	1.35	1.45	1.58	1.70	1.83	2.05	2.28
Blued, in bulk.....per lb.	2.23	1.62	1.28	1.12	0.98	0.82	0.63	0.48	0.44	0.40
Tinned, "....."	2.66	2.00	1.64	1.41	1.20	0.98	0.76	0.57	0.53	0.49

One dozen papers in a package; bulk, 25 lbs. in a box.

CHEESE BOX AND PAIL TACKS

FLAT HEAD CHEESE BOX TACKS

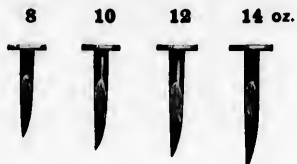

OVAL HEAD CHEESE BOX OR PAIL TACKS



Ounces.....	6	8	10	12	14	16	18
Length.....	4-8	4½-8	5-8	5½-8	6-8	6½-8	7-8 inch.
In bulk.....	per lb. \$0.40	0.31	0.29	0.28	0.27	0.26	0.26

In 1 lb. papers or 25 lb. boxes.

STRAWBERRY BOX TACKS

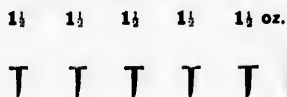

BRUSH TACKS

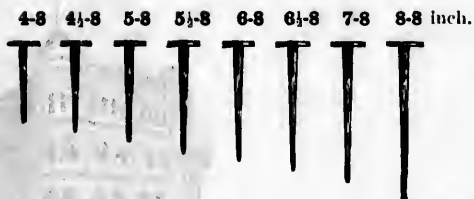

Strawberry Box Tacks, put up in lb. papers or in bulk..... per lb. \$0.80

BRUSH TACKS

Length.....	4-8	4½-8	5-8	5½-8	6-8	6½-8	7-8	7½-8	8-8	8-8 inch.
In bulk.....	per lb. \$0.72	0.58	0.48	0.41	0.36	0.32	0.29	0.26	0.24	0.22

CIGAR BOX NAILS

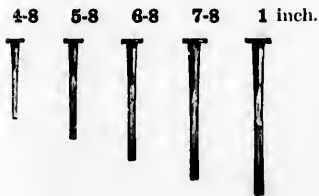

CHAIR NAILS

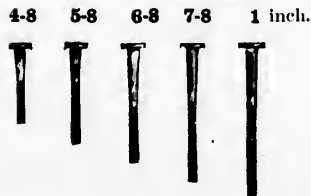

BASKET NAILS



CIGAR BOX, CHAIR OR BASKET NAILS

Length.....	¼	⅜	½	¾	1 inch.
Per lb.....	\$0.34	0.32	0.30	0.28	0.26

In lb. papers or in bulk 25 lb. boxes.



20	22	24
1.63	1.78	1.93
0.20	0.26	0.28

20	22	24
2.00	2.20	2.40
2.08	2.95	3.23
0.20	0.26	0.28

20	22	24
0.35	0.35	0.35

per lb. \$0.30



5	10	12
1.55	1.70	1.88
1.83	2.05	2.28
0.18	0.44	0.40
0.27	0.53	0.49

CLOUT NAILS

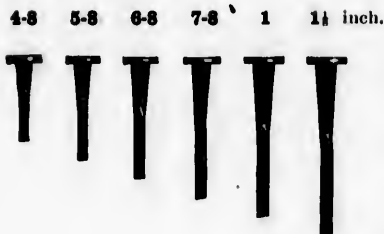

TRUNK NAILS



FINISHING, TRUNK AND CLOUT NAILS

Length	3/8	1/2	5/8	3/4	7/8	1	1 1/8	1 1/4	1 1/2	1 3/4	2 inch.
Per lb.....	\$0.42	0.30	0.24	0.20	0.18	0.16	0.16	0.10	0.10	0.10	0.16

TINNED TRUNK AND CLOUT NAILS

Length	3/8	1/2	5/8	3/4	7/8	1	1 1/8	1 1/4	1 1/2	1 3/4	2 inch.
Per lb.....	\$0.48	0.30	0.30	0.20	0.24	0.22	0.22	0.22	0.22	0.22	0.22

COPPER NAILS

TRUNK, CLOUT AND CIGAR BOX NAILS AND TACKS

All sizes, 1/4 to 2 inches long..... per lb. \$0.66

COPPER WIRE BOAT AND CANOE NAILS

With long points for clinching, or short points with bur or washer to match.

15 to 20 gauge, length 1/4 to 2 inches..... per lb.

STEEL WIRE BOAT AND CANOE NAILS

Annealed very soft with long points for clinching.

15 to 20 gauge, lengths 1/4 to 2 inches..... per lb.

IMPROVED GLAZIERS' POINTS



Nos. 00 0 1 2 3 4

Zinc, all sizes, in 1/4 lb. papers.....	per paper	0.07
Iron, " " ".....	"	0.00
Tin, " " ".....	"	0.08

DOUBLE POINTED STEEL CARPET TACKS

Nos. 3 9 10 11 12 14



SHADE TACK

Nos.	3	9	10	11	12	14
Length		$\frac{1}{2}$	$\frac{3}{4}$	$\frac{7}{8}$	$\frac{1}{2}$	$\frac{1}{2}$ inch.
Blued	per doz. papers	\$1.20	1.20	1.30	1.10	1.00
Tinned	"	1.80	1.80	1.95	2.10	2.40
Blued, in bulk	per lb.	0.10	0.10	0.09	0.09	0.08
Tinned, "	"					0.08
						0.03 net.

In dozens, packed 12 papers in a package, 12 packages in a case. In bulk, 50 and 100 lb. boxes.

Net extras: When packed in bulk 25 lb. boxes, 4c. per lb.; less than 25 lb. boxes, including 1 lb. papers, 4c. per lb.

OVAL HEAD LINING NAILS



Silver or Japanned.

2 1/2 to 12 oz., 75 to paper..... per paper \$0.04
Package contains 20 paper boxes.

SOLID HEAD LINING TACKS

Ounces..... 2 1/2 3 4 6 8 10
Japanned.. per lb. \$0.80 0.70 0.65 0.55 0.52 0.50

BEST FLOUR BARREL NAILS



Blued or Bright.

Length..... $\frac{3}{4}$ $\frac{7}{8}$ 1 1 1/2 inch.
Per keg..... (100 lbs.) \$8.25 7.75 7.50 7.00
Coopers' Nails, (Light) same price.

STEEL AND BRASS ESCUTCHEON PINS

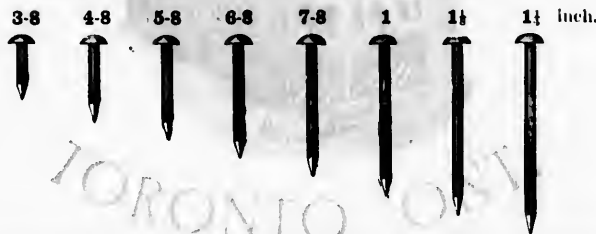

STEEL AND IRON ESCUTCHEON PINS

In 1 lb. paper boxes.

Price, per lb.

Inch.	3/16	1/4	5/16	3/8	7/16	1/2	5/8	3/4	1	1 1/8	1 1/4	1 1/2	1 3/4	2
Wire Gauge.														
12	27	25	24	23	22	21	20	19	18	17	17	17	17	17
13	28	26	25	24	23	22	21	20	19	19	19	19	19	19
14	40	33	30	28	26	25	24	23	22	21	21	21	21	21
15	45	35	32	30	28	27	26	25	24	24	24	24	24	24
16	50	40	35	32	30	29	28	28	28	28	28	28	28	28
17	55	45	37	34	32	30	29	28	28	28	28	28	28	28
18	60	50	40	36	34	32	30	30	30	30	32	33	35	35
19	70	55	50	45	40	35	35	38	38	38	40			
20	85	65	60	50	45	40	40	45	45	45				
21	100	80	70	60	55	55	60	60						
22	125	100	85	70	65	70								

BRASS ESCUTCHEON PINS

In 1 lb. paper boxes.

Price, per lb.

Inch.	3/16	1/4	5/16	3/8	7/16	1/2	5/8	3/4	1	1 1/8	1 1/4	1 1/2	1 3/4	2
Wire Gauge.														
12	77	75	74	73	72	71	70	69	68	67	67	67	67	67
13	78	76	75	74	73	72	71	70	69	69	69	69	69	69
14	90	83	80	77	76	75	74	73	72	71	70	70	70	70
15	95	85	82	78	77	76	75	74	73	72	72	72	72	72
16	100	90	85	82	80	78	76	75	74	74	74	74	74	75
17	110	100	92	89	87	85	83	81	80	80	80	81	82	82
18	120	110	100	96	94	92	90	90	90	92	92	93	95	95
19	135	120	115	110	105	100	100	103	103	103	105			
20	155	135	125	120	115	110	110	115	115	115				
21	175	155	145	135	130	130	135	135						
22	200	175	160	145	140	145								

Tinned, 50 per cent. advance on list price. Headless Curtain Stretcher Pins included in above list.

CUT NAILS

In 100 lb. kegs.

Branded.....	3dy	4dy	4½dy	5dy	6dy	7dy	8dy	9dy	10dy	12dy	16dy	20dy	30dy	40dy	50dy	60dy
Length.....	1½	1½	1¾	1¾	2	2¼	2½	2¾	3	3¼	3½	4	4½	5	5½	6 inch.

STANDARD LIST IRON AND STEEL CUT NAILS, AND CUT SPIKES

Adopted January 6th, 1898. Subject to change without notice.

Iron Cut Nails, Base 30 to 70dy.....per keg \$.....

EXTRAS

CUT AND FENCE NAILS

Size.....	16 to 20dy	10 to 12dy	8 and 9dy	6 and 7dy	4 and 5dy	3dy	2dy
Advance per 100 lbs.	\$0.05	0.10	0.15	0.30	0.40	0.65	1.00

FINE BLUED NAILS

3dy—Advance.....	per 100 lbs.	\$1.00
2dy ".....	"	1.50

CASING, BOX, TOBACCO BOX AND FLOORING NAILS

Size.....	20 to 30dy	10 to 16dy	8 and 9dy	6 and 7dy	4 and 5dy	3dy
Advance per 100 lbs.	\$0.55	0.60	0.65	0.70	0.95	1.20

FINISHING NAILS

Size.....	3 inch and longer	2½ and 2¾	2 and 2¼	1½ and 1¾	1¼	1 inch.
Advance.....per 100 lbs.	\$0.60	0.65	0.70	0.95	1.20	1.50

SLATING NAILS

Size.....	1½ and 1¾	1¼	1 inch.
Advance.....per 100 lbs.	\$0.95	1.20	1.50

COMMON BARREL NAILS

Size.....	1½	1	¾	¾ inch.
Advance.....per 100 lbs.	\$1.00	1.00	1.25	1.50

CLINCH NAILS

In 50 lb. boxes.

Size.....	3 inch and longer	2½ and 2¾	2 and 2¼	1½ and 1¾	1¼	1 inch.
Advance.....per 100 lbs.	\$0.60	0.65	0.70	0.95	1.20	1.50

SHARP AND FLAT PRESSED NAILS

In 50 lb. boxes.

Size.....	3 inch and longer	2½ and 2¾	2 and 2¼	1½ and 1¾	1¼	1 inch.
Advance.....per 100 lbs.	\$1.35	1.50	1.65	1.85	2.50	3.00

WROUGHT IRON COUNTERSUNK CLOUT NAILS



Length.....	1	1¼	1½	1¾	2	2¼	2½	2¾	3	3½	4 inch.
Gauge.....	8	7	6	4	3	3	2	2	1	1	⅞
Per 100 lbs.....	\$15.40	13.60	12.75	12.00	11.25	10.90	10.50	10.50	10.15	10.15	10.15

STEEL WIRE NAILS

STANDARD COMMON NAILS In Kegs.

STANDARD GAUGES

Size.	Length in Inches.	Gauge.	Advance over Base Price.	STANDARD GAUGES												
				Moulding.	Finishing and Casings.	Flooring.	Clinch Long Point.	Clinch Flat Point.	Slating and Roofing.	Box.	Fence.	Tobacco.	Barrel.	Oval Head Car.	Edge Trigh Spikes.	Common Spikes.
2d	1	15	\$1.00	16	17	..	14	14	12	14
3d ^F	1 1/4	15		16	17	12	14
3d	1 1/4	14	0.65	15	16	..	13	11	11	14
4d	1 1/2	13		14	15	..	12	13	11	14	..	12	..	12
5d	1 3/4	12	0.40	13	14	..	12	13	10	14	10	12	..	10
6d	2	12		12	13	11	11	12	10	13	10	11	..	10
7d	2 1/4	11	0.30	12	13	11	11	12	11	13	9	11	..	9
8d	2 3/4	10 1/2		11	12	10	10	11	11	12	9	10	..	9
9d	2 3/4	10	0.15	11	12	10	10	10	11	8	8	
10d	3	9		10	11	9	9	9	..	11	7	8
12d	3 1/4	9	0.10	9	11	9	10	6	6	
16d	3 3/4	7		8	10	8	10	5	7
20d	4	6	0.05	..	9	7	9	4	0	..	3	
30d	4 1/2	5		9	6	5	3
40d	5	4	Base	8	5	4	2	
50d	5 1/2	3		4	3	2
60d	6	2	4	2	1	

Base Price { C.L. \$
L.C.L. \$

Net Extras over same size Common Nails.

1c. 1c. 1c. 1c. 1c. 1c. 1c. 1c. 1c. 1c. 1c. 1c. per lb.

OTHER EXTRAS, NET

Barbing, Annealing, Special Heads, Special Points	1c. per lb. each, net.
Packing in 25 and 50 lb. boxes	1/2 "
Packing in less than 25 lbs. and in 1 lb. papers	1/4 "
Blued Nails	10c. per 100 lbs., net.
Coated Nails	10 "

Moulding, Finishing, Casings, Flooring, Clinch, Slating, Roofing, Box, Fence, Shingle, Tobacco, Barrel, Edge Trough Spikes and Car Nails of the Gauges named above will be charged at Common Nail List, with extras as shown. All other Sizes and Gauges will be charged by the Miscellaneous List.

MISCELLANEOUS WIRE NAIL LIST. Applying to all Nails except Standard Nails.

LENGTH.	Gauge.	Per lb.	LENGTH.	Gauge.	Per lb.	LENGTH.	Gauge.	Per lb.
1/4	No. 19 and heavier..	\$0.65	1 and 1 1/4	No. 16 and heavier.	\$0.20	3 and 3 1/4	No. 10 and heavier.	\$0.16
	" 20	0.80		" 17	0.28		" 11	0.17
	" 21	0.95		" 18	0.30		" 12	0.18
1/2	No. 19 and heavier..	0.55	1 1/4 and 1 1/2	No. 15 and heavier.	0.22	3 1/2 and 4	No. 9 and heavier.	0.16
	" 20	0.65		" 16	0.23		" 10	0.17
	" 21	0.75		" 17	0.25		" 11	0.18
3/4	No. 18 and heavier..	0.45	1 1/2	No. 14 and heavier.	0.21	4 1/2	No. 7 and heavier.	0.15
	" 19	0.50		" 15	0.23		" 8	0.16
	" 20	0.55		" 16	0.25		" 9	0.17
1	No. 18 and heavier..	0.35	1 3/4	No. 13 and heavier.	0.19	5	No. 6 and heavier.	0.15
	" 19	0.40		" 14	0.20		" 7	0.16
	" 20	0.45		" 15	0.23		" 8	0.17
1 1/4	No. 17 and heavier..	0.30	2 and 2 1/4	No. 12 and heavier.	0.17	5 1/2	No. 4 and heavier.	0.14
	" 18	0.35		" 13	0.20		" 5	0.15
	" 19	0.40		" 14	0.22		" 6	0.16
1 1/2	No. 16 and heavier..	0.25	2 1/2 and 2 3/4	No. 11 and heavier.	0.17	6 and longer	No. 3 and heavier.	0.14
	" 17	0.30		" 12	0.18		" 4	0.15
	" 18	0.35		" 13	0.19		" 5	0.16

NET EXTRAS

Sash Pins or Headless Nails	1c. per lb.	Packing in 25 and 50 lb. boxes	1c. per lb.
Barbing, Annealing, Special Heads or Points	1/2 "	Packing in less than 25 lbs. and in lb. papers	1/4 "
Tinning, up to 1/2 inch	6 "	Blued Nails	10c. per 100 lbs.
" 1/2 inch and longer	3 "	Coated Nails	10 "
Galvanizing	3 "		

In addition to these Extras, Nails on the above list in less than 100 lbs. of one size, 1c. per lb. extra, net.

WROUGHT SHIP SPIKES

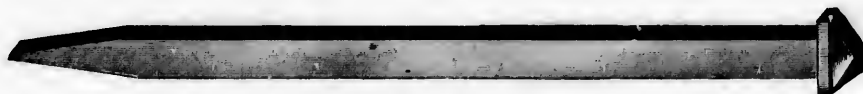

Full size cut, $5\frac{1}{2} \times \frac{1}{4}$ inch.

In kegs of 100 lbs.

Thickness.	Lengths.		per 100 lbs.	
$\frac{1}{4}$ inch	$\times 4, 4\frac{1}{2}, 5, 5\frac{1}{2}, 6, 7, \dots$	inch.....		\$4.75
$\frac{5}{16}$ "	$\times 4, 4\frac{1}{2}, 5, 5\frac{1}{2}, 6, 6\frac{1}{2}, 7, 8$	"		4.50
$\frac{3}{8}$ "	$\times 4, 5, 5\frac{1}{2}, 6, 6\frac{1}{2}, 7, 8, 9$	"		4.25
$\frac{7}{16}$ " and thicker	$\times 6, 7, 8, 9, 10, 11, \dots$	"		3.90

TRAM RAIL SPIKES



$\frac{3}{4} \times 4$ inch per 100 lbs.

RAILWAY SPIKES

In casks or cases of 224 lbs., or other weights if desired.

$\frac{1}{2}$ inch $\times 5, 5\frac{1}{2}$ inch	per 100 lbs.
$\frac{5}{8}$ " $\times 5, 5\frac{1}{2}, 6, 9$ inch	"

RAILWAY TRACK BOLTS

Prices quoted on application

BOAT NAILS



CLINCH RINGS



ROUND COUNTERSUNK OVAL HEAD

$\frac{1}{2}$ inch Diameter, Lengths	$1\frac{1}{2}$	2	$2\frac{1}{2}$	3 inch.
Per lb.....	\$.....

ORDINARY PATTERN, SWEDES IRON

Regular Points, in 25 lb. boxes.

Length, 1 and $1\frac{1}{4}$ inch.....	per lb.	Galvanized.	Black.
" $1\frac{1}{4}$	"	\$0.14	0.11
" $1\frac{1}{2}$ and $1\frac{3}{4}$	"	0.13	0.10
" 2 " $2\frac{1}{4}$	"	0.12	0.09 $\frac{1}{2}$
" $2\frac{1}{2}$ " $2\frac{3}{4}$	"	0.11	0.09
" 3 and longer	"	0.10 $\frac{1}{2}$	0.08 $\frac{1}{2}$
		0.10	0.08

COUNTERSUNK HOLE

Size.....	$\frac{1}{2}$	$\frac{5}{8}$	$\frac{3}{4}$	$\frac{7}{8}$	1	$1\frac{1}{4}$ inch.
Per lb.....	\$0.16	0.15	0.14	0.14	0.13	0.13

BUILDERS' HARDWARE

HAND OF DOORS

Useful Information Regarding

THE HAND OF LOCKS AND LATCHES



Fig. 1

LEFT HAND DOOR



Fig. 2

RIGHT HAND DOOR

The above cuts are inserted as a guide to enable customers when ordering to properly specify whether **Right** or **Left Hand** Locks or Latches are wanted. The hand of a door is **always** determined from the outside. When the hinges of the door are on your **right hand** as you stand outside about to enter it is a **right hand door**, Fig. 2. When the hinges are on the **left hand** it is a **left hand door**, Fig. 1. Such doors usually open **inwards**, but the hand is the same whether they open inward or outward; but if the door opens outward the bevel of the latch bolt must be reversed.

Reverse Bevel, locks are usually found on outer doors of public buildings, and the fact should always be stated in ordering.

English Rim Locks are opposite of the above.

DESCRIPTION OF FINISHES

ON BRONZE METAL

- No. **1** —Light Bronze (Natural Color).
“ **2** —“Chocolate” or Statuary Bronze.
“ **3** —Light or Natural Color Surface, Black Background.
“ **5** —Nickel-Plated.
“ **8** —Gold-Plated, Burnished.
“ **08** — “ “ “Satin” Finish.
“ **19** —Oxidized Silver.
“ **A19** — “ “ Sand Blast Finish.
“ **O19** —Electro “ “Satin” Finish.
“ **20** —Antique Brass.
“ **20₁** — “ “ Light “Satin” Finish.
“ **A20₁** — “ “ Sand Blast Finish.
“ **22** — “ Copper.
“ **22₁** — “ “ Medium.
“ **22₂** — “ “ Light.
“ **A22** — “ “ Sand Blast Finish.
“ **A22₁** — “ “ “ “ Light.

ON IRON OR STEEL

In addition to Amber Bronzed Finish on Iron or Steel Goods, we now have Nubian, Persian, and Roman Bronzed Finishes, which we designate as follows:—

- N** Prefixed to No. of article, indicates “Nubian Bronzed (Plain, Bronze-Plated).
P “ “ “ “ “Persian Bronzed” (Bronze-Plated Surface, with Black Background, No. 10 Finish).
R “ “ “ “ “Roman Bronzed” (Antique Copper-Plated).
X “ “ “ “ “Bower-Barff” or Rustless Iron, No. 23 Finish).
NP Indicates Nickel-Plated.
D2 “ “ “ “ “Antique Copper.
SD2 “ “ “ “ “Sand Blast Finish.

In ordering, use the No. or Letter of the Finish desired.

Extra charge will be made for Finishes other than Nos. 1, 2, or 3, on Bronze Metal, or where it has not been mentioned with the articles priced.

ORNAMENTAL BRASS BUTTS

Cuts full size.

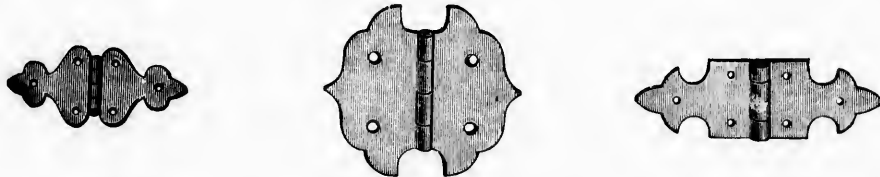

No. 15.....per doz. pair \$0.35 | No. 1.....per doz. pair \$1.35 | No. 6.....per doz. pair \$0.85

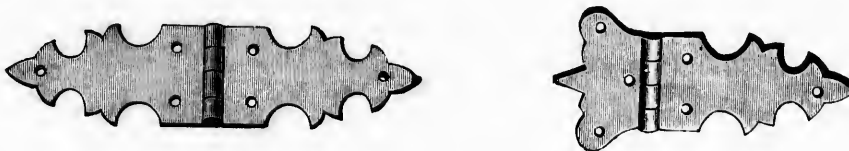

No. 7.....per doz. pair \$1.50 | No. 25.....per doz. pair \$2.00

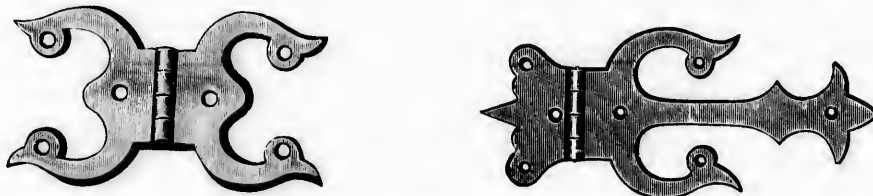

No. 26.....per doz. pair \$2.40 | No. 4.....per doz. pair \$2.30

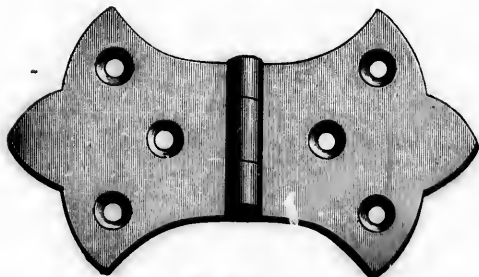

No. 75

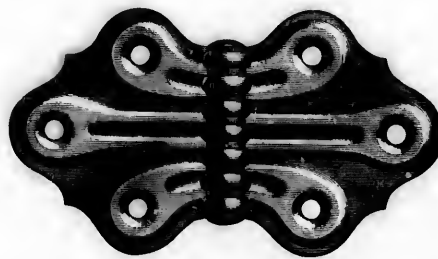

No. 1430

No. 75—Brass, Polished	per doz. pair	\$1.80	No. 1430—Brass, Polished	per doz. pair	\$3.00
" 123—Bronze Metal, 2½ × 3¼	" "	16.00	" 1430, D2—Old Copper	" "	3.25
			" 1430N—Nickel-Plated	" "	3.50

One dozen pair in a box.

ORNAMENTAL BUTTS

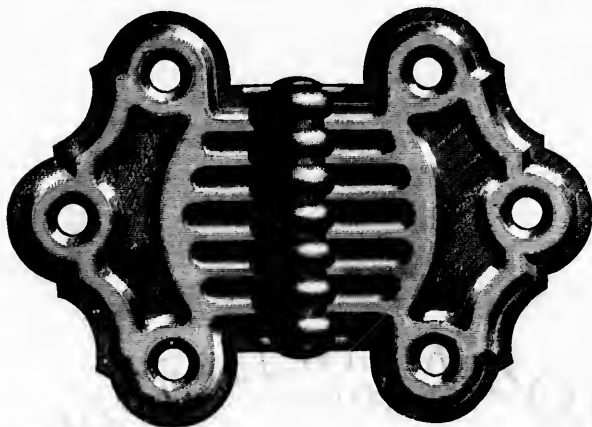

No. **1416**—Wrought Brass, Polished. per doz. pair \$8.00

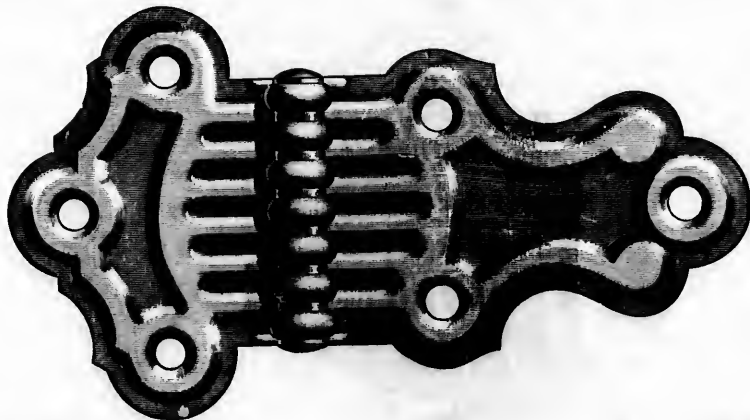

No. **1405C**—Steel, Brass Plated. per doz. pair 5.00
 " **1408** —Wrought Brass, Polished, with $\frac{1}{2}$ Offset for Refrigerators " " 7.00

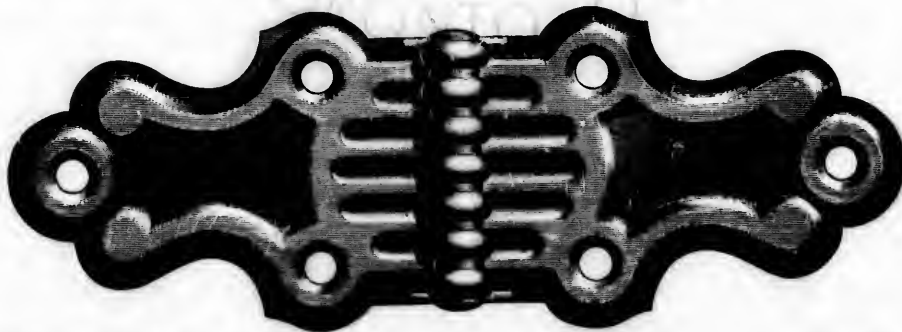

No. **1412**—Wrought Brass, Polished. per doz. pair 7.00

Cuts full size. Half-dozen pair in a box.

STRAP HINGES



No. 102—Brass, Polished.....per doz. pair \$2.50 | No. 13—Brass, Polished, $1\frac{1}{2} \times \frac{3}{8}$ in.... per doz. pair \$2.00

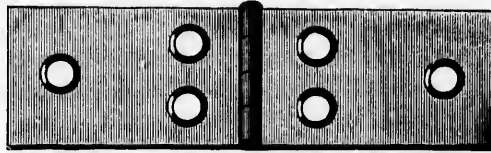

No. 104—Brass, Polished, $1\frac{1}{2} \times 1$ in.....per doz. pair \$3.00

ORNAMENTAL HINGES



Size.....		$1\frac{3}{4} \times 1\frac{3}{4}$	$2\frac{1}{2} \times 2\frac{1}{2}$ inch.
No. 1421— Brass, Polished.....	per doz. pair	\$5.00	5.00
“ 1423— “ “ with $\frac{3}{8}$ offset.....	“ “	5.40	6.00

SCREEN BUTTS

WROUGHT BRASS, POLISHED, DOUBLE ACTING

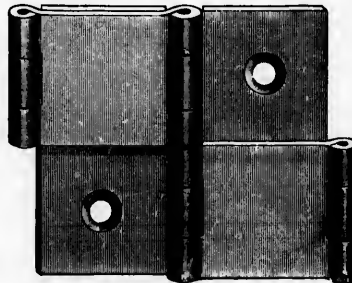

$1\frac{1}{2} \times 1\frac{1}{2}$ inch.

Size.....		$1\frac{3}{4} \times 1\frac{1}{2}$	$2 \times 1\frac{1}{2}$ inch.
No. 105.....	per doz. pair	\$8.50	8.10

WROUGHT BRASS BUTTS

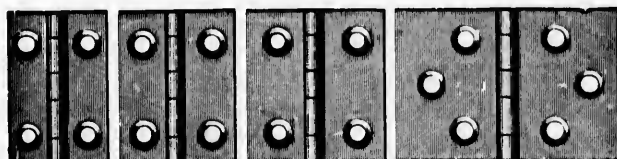

NARROW MIDDLE BROAD DESK

Full size cuts of 1 inch.

Size.....		½	¾	⅞	1	1 1/8	1 1/4	1 1/2	1 3/4	2	2 1/4	2 1/2	2 3/4	3 inch.
Narrow.....	per doz. pair	\$0.24	0.28	0.30	0.32	0.40	0.46	0.52	0.68	0.80	1.12	1.35	2.00	2.50
Middle.....	" "	0.26	0.30	0.34	0.38	0.44	0.48	0.00	0.76	0.92	1.30	1.70	3.00
Broad.....	" "	0.28	0.32	0.36	0.40	0.48	0.54	0.68	0.84	1.04	1.50	2.00	..	3.50
Desk.....	" "	0.40	0.50	0.60	0.72	0.84	1.20	2.00	2.80

Width of Brass Butts when Open

Size.....		½	¾	⅞	1	1 1/8	1 1/4	1 1/2	1 3/4	2	2 1/4	2 1/2	2 3/4	3 inch.
Narrow—Width.....		½	¾	⅞	1	1 1/8	1 1/4	1 1/2	1 3/4	2	2 1/4	2 1/2	2 3/4	3
Middle.....	Width.....	¾	1	1 1/8	1 1/4	1 1/2	1 3/4	2	2 1/4	2 1/2	2 3/4	3	3 1/4	3 1/2
Broad.....		1	1 1/8	1 1/4	1 1/2	1 3/4	2	2 1/4	2 1/2	2 3/4	3	3 1/4	3 1/2	3 3/4
Desk.....		1 1/4	1 1/2	1 3/4	2	2 1/4	2 1/2	2 3/4	3	3 1/4	3 1/2	3 3/4	4	4 1/4

Sizes of Screws to Fit Brass Butts

Size of Butt.....		½	¾	⅞	1	1 1/8	1 1/4	1 1/2	1 3/4	2	2 1/4	2 1/2	2 3/4	3 inch.
Narrow, Middle or Broad.....		0	1	1	2	2	3	4	4	4	5	5	6	7 screw
Desk.....		1	2	2	4	4	4	4	5	5	6	6	7	..

WROUGHT SHUTTER BUTTS

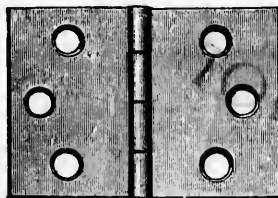

1 1/2 x 1 3/4 inch.

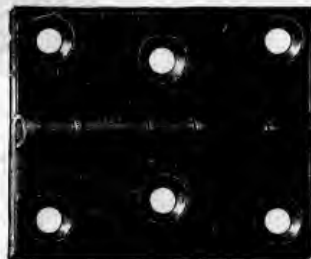

2 x 1 3/4 inch.

BRASS, NOT POLISHED

Size.....		1 x 1 1/2	1 1/8 x 1 3/4	1 1/4 x 1 3/4	1 1/2 x 2	1 3/4 x 2 1/2	2 x 3 inch.
No. 09.....	per doz. pair	\$0.84	0.84	0.84	1.10	2.00	3.00

BRONZE METAL, POLISHED

Size.....		1 1/4 x 1 3/4	1 1/4 x 2	1 1/2 x 2	2 x 1 3/4	2 x 2 inch.
No. 0029—Packed with Screws.....	per doz. pair	\$1.20	1.30	1.60	2.10	2.50

One dozen pair in a box.

WATER CLOSET HINGES

Cuts quarter size.

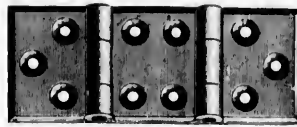

No. 121

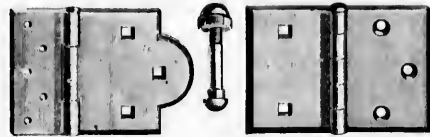

No. 597

No. 0597

No. 121	—Bronze Metal, $1\frac{1}{2} \times 3\frac{1}{2}$ inch.....	per doz. pair	\$8.00
" 597	" " $3\frac{1}{2} \times 5$ " complete with Screws and Bolts	per pair	5.65
" 0597	" " $3\frac{1}{2} \times 5$ " " " " "	"	5.65

DRAPER'S ADJUSTABLE CLAMP AND HINGE COMBINED

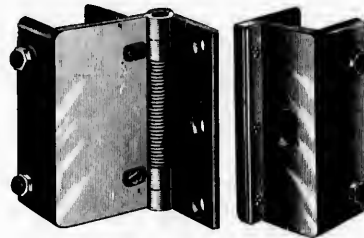

No. 598

No. 0598

For Water Closet Doors.

The Clamp, which is part of the Hinge, is made to adjust one quarter of an inch to allow for any variation in the thickness of the marble, thereby avoiding the necessity and expense of cutting marble to receive the Clamp. The Hinges are made for doors from $\frac{3}{4}$ to $1\frac{1}{2}$ inch thick, with Clamps adjustable for marble $1, 1\frac{1}{2}$ and $1\frac{3}{4}$ inch thick.

BRASS, NICKEL-PLATED

No. 598	—Hinge to keep door closed	per pair	\$11.25
" 598 $\frac{1}{2}$	" " " open.....	"	11.25
" 0598	—Strike for Mortice Bolt No. 164B.....	each	7.50
" 0598 $\frac{1}{2}$	" " " 650.....	"	7.50

In ordering, state thickness of both door and marble.

WATER CLOSET BOLTS



WATER CLOSET LATCH

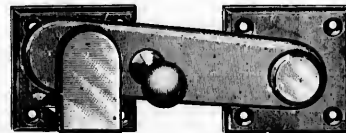

No. 156—Bronze Metal.....	each	\$1.90		No. 599—Nickel-Plated.....	each	\$1.25
---------------------------	------	--------	--	----------------------------	------	--------

TRUNK HINGES

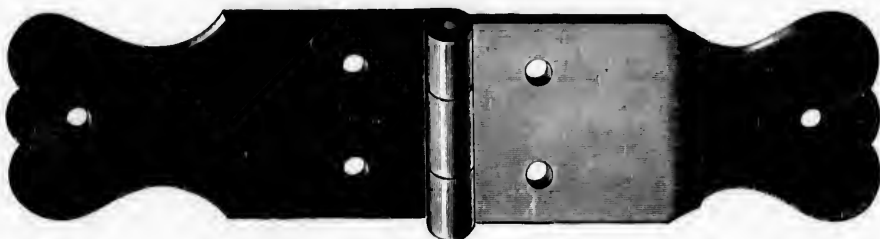

No. 1741—6 inch, Iron, Japanned..... per doz. pair \$0.50

TRUNK HINGE AND STAY



No. 1726



No. 1710

No. 1726—6 $\frac{3}{4}$ inch, Steel, Japanned..... per single doz. \$2.80

" 1710—6 $\frac{3}{4}$ " Iron, " " " 2.50

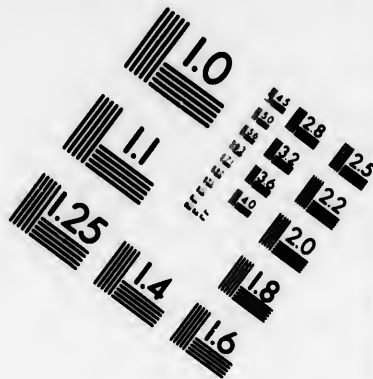
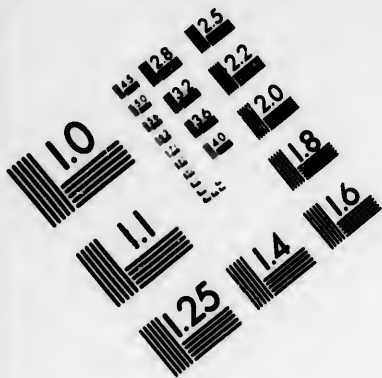

**IMAGE EVALUATION
TEST TARGET (MT-3)**

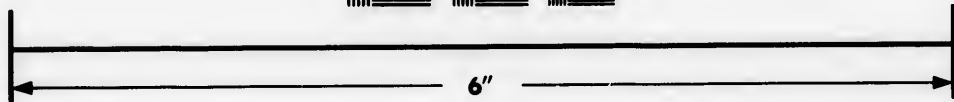
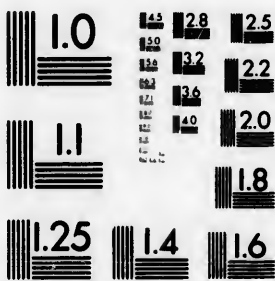

**Photographic
Sciences
Corporation**

23 WEST MAIN STREET
WEBSTER, N.Y. 14580
(716) 872-4503

1.5 1.8
2.0 2.2
2.5 2.8
3.2 3.6
4.0 4.5
5.0

10
15
20
25
30
35
40
45
50
55
60
65
70
75
80
85
90
95
100

WROUGHT STEEL BUTTS



Full size, 2 inch.

NARROW, FAST JOINT, BRIGHT

Size.....	1	1½	1½	1¾	2	inch.
No. 800..... per doz. pair	\$0.32	0.36	0.43	0.50	0.60	
Size.....	2¼	2½	3	3½	4	inch.
No. 800..... per doz. pair	\$0.66	0.72	0.90	1.44	1.92	

LIGHT NARROW, FAST JOINT, BRIGHT

Size.....	1	1½	1½	1¾	2	2½	inch.
No. 838..... per doz. pair	\$0.32	0.36	0.43	0.50	0.60	0.66	

¾ inch and smaller, one dozen pair in box ; 4 inch, half dozen.

LIGHT NARROW, LOOSE PIN BUTTS, BRIGHT

Size.....	1½	1¾	2	2¼	2½	3	inch.
No. 840..... per doz. pair	\$0.56	0.65	0.78	0.86	0.94	1.10	

One dozen pair in a box.

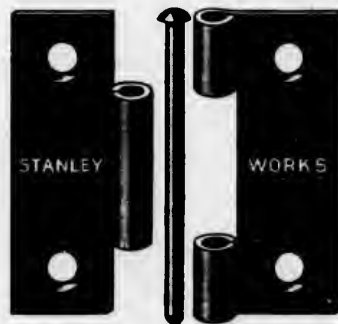

Full size, 2 inch.

WROUGHT STEEL REVERSIBLE BUTTS, LOOSE PIN, BRIGHT

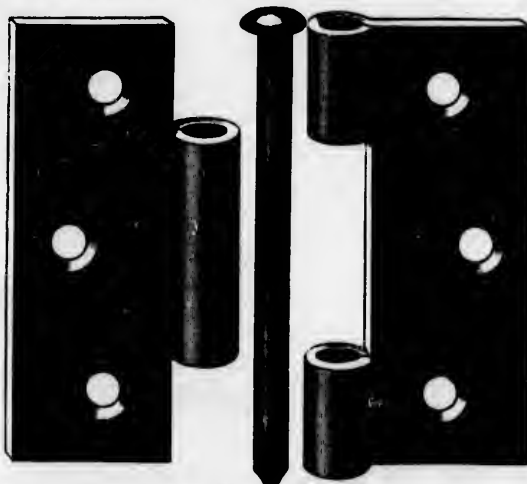

Full size, 3 x 2½ inch.

Size.....	2½ x 2½	3 x 2½	3 x 3	3½ x 3	3½ x 3½	4 x 4	4½ x 4½	5 x 5	6 x 6	inch.
No. 804..... per doz. pair	\$1.32	1.08	1.86	2.40	2.70	3.90	4.25	5.50	7.00	

Up to 3 x 3, one dozen pair in box ; larger sizes, one-half dozen.

WROUGHT STEEL BUTTS

2 inch.
0.00

4 inch.
1.92

2½ inch.
0.66

1.

WORKS

3 x 6 inch.
7.00



No. 842, cut of 1½ inch

LIGHT INSIDE BLIND BUTTS

No. 842, BRIGHT

Size.....	1	1½	1¾	1¾	1½ inch.
Per dozen pair....	\$0.45	0.50	0.55	0.60	0.65



No. 844, cut of 1½ inch

LIGHT INSIDE BLIND BUTTS

No. 844, LOOSE PIN, BRIGHT

Size.....	1¾	1¾	1¾	1½ inch.
Per dozen pair.....	\$0.70	0.75	0.80	0.85

No. 834, LOOSE PIN, BRIGHT

Size.....	2 x 2½ inch.			
Per dozen pair.....	\$1.20			

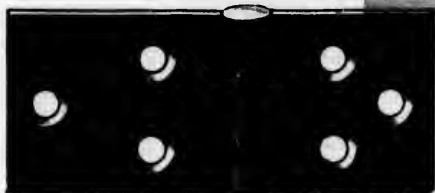

No. 810, cut of 1½ inch

TABLE HINGES

No. 810, BRIGHT

Size.....	1	1½	1¾	1¾	1½ inch.
No. 810, per doz. pair.	\$0.45	0.50	0.55	0.60	0.65



No. 814, cut of 1½ inch

BACK FLAPS

No. 814, BRIGHT

Size.....	1	1½	1¾	1¾	1¾	1¾	2 in.
No. 814 ...doz. pair	\$0.50	0.55	0.60	0.65	0.70	0.80	0.90

One dozen in a box.

PARLIAMENT BUTTS

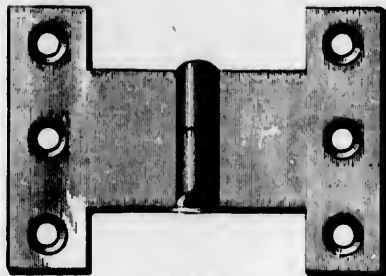

No. 018, 2½ inch.

WROUGHT-STEEL, LOOSE JOINT, BRIGHT

Size, Open.....	3	3½	4	4½	5	6	inch.
No. 830.....per doz. pair	\$1.00	1.80	1.90	2.00	2.10	2.50	

WROUGHT STEEL, LOOSE JOINT, ACORN TIP

Size, Open.....	3½	4	4½	5	6	inch.
No. 828.....per doz. pair	\$3.30	3.40	3.50	3.00	4.00	

WROUGHT BRASS, LOOSE JOINT

Size, Open.....	1¼ × 2½	inch.
No. 018.....per doz. pair	\$2.70	

4 inch and smaller, one dozen pair in a box; 4½ and larger, half dozen.

WATER CLOSET HINGES

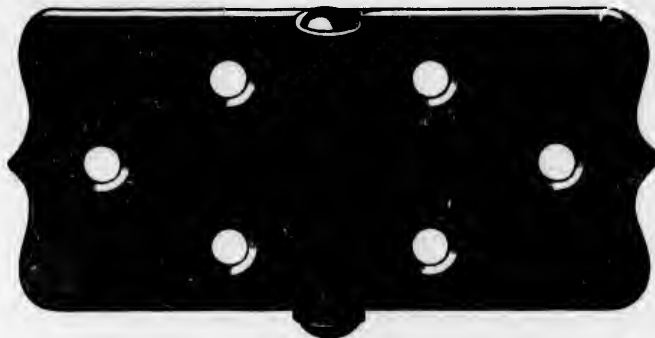

No. 1426, 2 inch.

Size, Length of Joint.....	1¼	2	inch.
No. 1426—Steel, Planished and Bronzed.....per doz. pair, with Screws	\$2.20	2.50	

LOOSE PIN BUTTS

LIGHT NARROW STEEL, BALL TIPS

Size.....	2½ × 2	2½ × 2½	inch.
No. 289 — Planished and Bronzed.....per doz. pair	\$3.40	3.00	
" 289, D2—Old Copper.....	4.30	4.50	

BRONZE METAL, POLISHED, BALL TIPS

Size.....	2½ × 1¼	3 × 2	inch.
No. 039½.....per doz. pair	\$3.70	5.70	

One dozen pair in a box, with Screws.

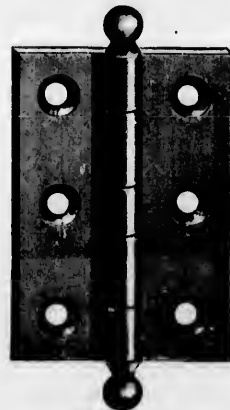

No. 039½, 2 × 1½ inch.

Size...
No. 823
" 731
" 737
" 241
" 241
" 241
" 241

Size...
No. 61...

The a
Screws.

LOOSE PIN BUTTS

WITH BALL TIPS



6 inch.
3.50
IP
6 inch.
4.00
3 1/2 inch.
70
half dozen.

2 inch.
2.50



Size.....		3 x 3	3 1/2 x 3 1/2	4 x 4	4 1/2 x 4 1/2	5 x 5 inch.
No. 823—Bright Steel.....	per doz. pair	\$1.80	2.10	2.60	3.10	3.90
" 731—Japanned.....	"	3.50	4.00	5.00	6.00	7.50
" 727— " N. P. Tips.....	"	0.50	0.80	0.90	1.00	1.20
" 241, D2—Old Copper.....	per single pair	0.55	0.65	0.75
" 241, SD2— " Sand Finish.....	"	0.70	0.80	0.90	1.10
" 241—Polished and Bronzed.....	"	0.75	0.85	0.95	1.05	1.25
" 241 1/2, D2—Old Copper.....	"	0.60	0.65	0.75	0.85	1.00

Brass Plated Butts, same price as No. 241 1/2, Polished and Bronzed.

BRONZE METAL LOOSE PIN BUTTS

Polished, Steel Bushed, same design as above.

Size.....		3 x 3	3 1/2 x 3 1/2	4 x 4	4 1/2 x 4 1/2	5 x 5	5 1/2 x 5 1/2	6 x 6 inch.
No. 61.....	per single pair	\$1.80	2.10	2.60	3.10	3.90	5.50	7.00

No. 61 can be supplied in Old Copper, Oxidized Silver or Bower-Barff to order.

The above, one pair in a box with Screws; excepting Nos. 823, 731 and 727, packed half-dozen pair without Screws.

LOOSE PIN BUTTS

WROUGHT STEEL, BALL-BEARING WASHERS

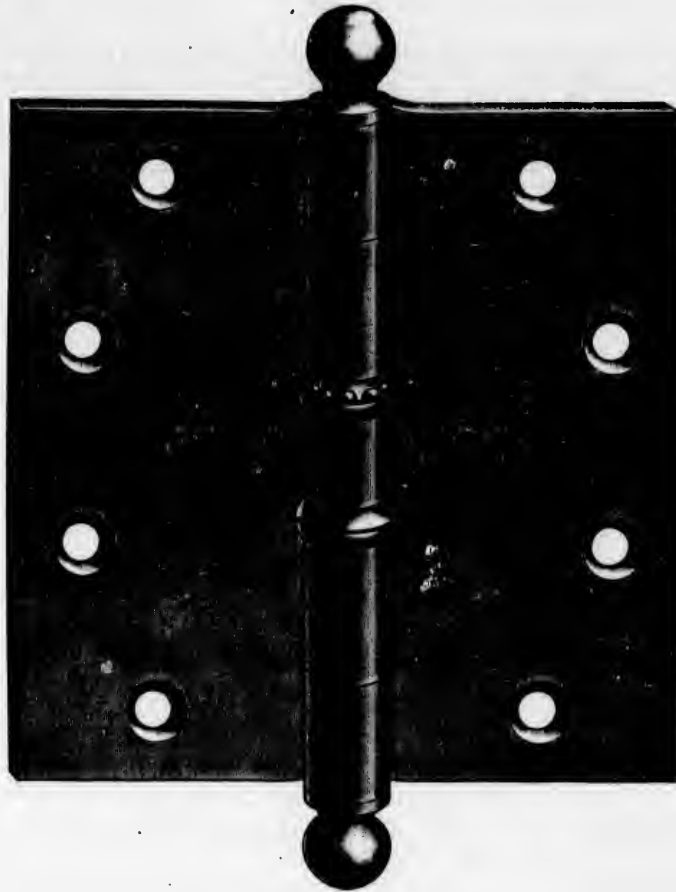

4½ × 4½ inch, with Ball-Bearing Washers

ADVANTAGES:—Unlimited resistance to wear. No necessity for oiling. Noiseless in operation.

Size.....		4½ × 4½	5 × 5	6 × 6 inch.
No. 239—Polished and Bronzed.....	per pair	\$2.10	2.30	2.90
“ 239, D2—Old Copper.....	“	2.20	2.40	3.00
“ 239, SD2— “ Sand Finish.....	“	2.30	2.50	3.10

One pair in a box, with Screws.

REVERSIBLE BUTTS

WROUGHT STEEL, WITH IMPROVED PIN AND TIPS

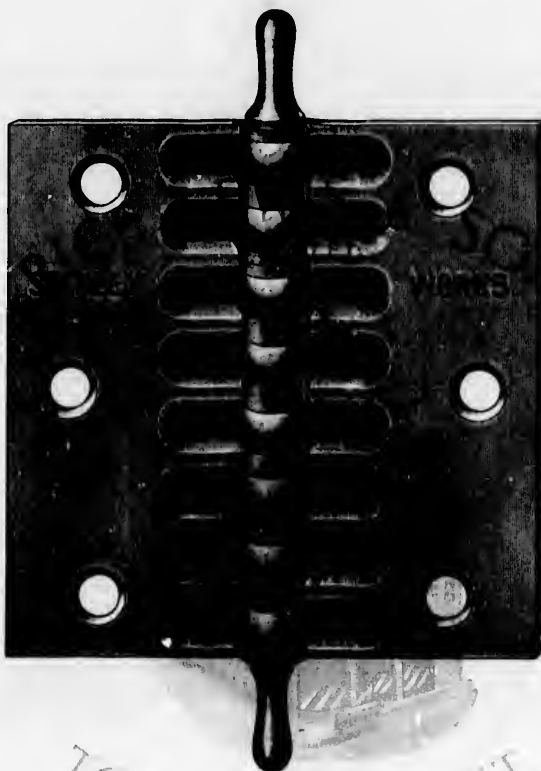

Full size cut of $3\frac{1}{2} \times 3\frac{1}{2}$.

PLANISHED AND BRONZED

Size.....	3 x 3	$3\frac{1}{2} \times 3\frac{1}{2}$	4 x 4 inch.
No. 854A.....	per doz. pair	\$3.25	4.00 4.90

One-half dozen pair in a box, with Screws.

The corrugations above the joint greatly increase the strength of the butt, at the same time adding very much to its appearance. The tips and pin are one piece of solid steel, turned from a steel rod, and while a shoulder on the upper tip prevents the pin from falling out, it can be driven out, when necessary, by a sharp blow on the lower tip.

ration.

5 6 x 6 inch.
0 2.00
0 3.00
0 3.10

LOOSE PIN ACORN TIP BUTTS

RIGHT OR LEFT HAND

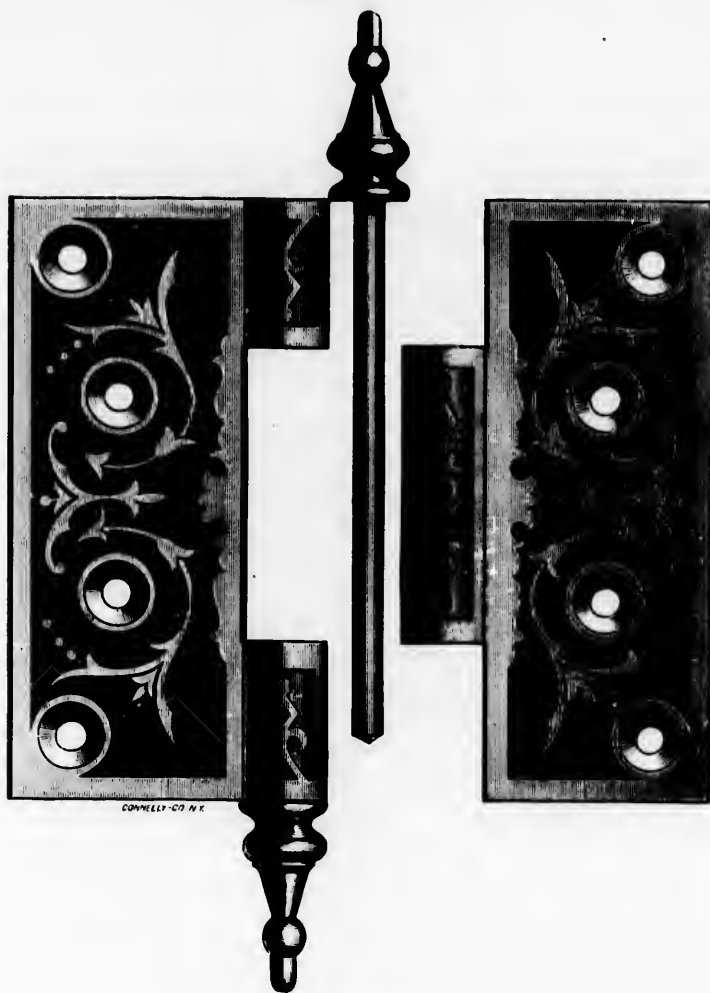

Full size cut, 4 x 4 inch.

No. 1800, NOT JAPANNED

Size.....	2½ x 2½	3 x 2½	3 x 3	3½ x 3	3½ x 3½	4 x 4	4½ x 4½	5 x 5 inch.
No. 1800.....per doz. pair	\$1.35	1.00	1.75	2.15	2.35	2.90	4.00	5.50

No. 1801, JAPANNED

Size.....	3 x 2½	3 x 3	3½ x 3	3½ x 3½	4 x 4	4½ x 4½	5 x 5 inch.
No. 1801.....per doz. pair	\$2.80	3.00	3.45	3.70	4.50	5.50	7.00

Half-dozen pair in a box.

LOOSE PIN BALL TIP BUTTS

RIGHT OR LEFT HAND



Full size cut of $4\frac{1}{2} \times 4\frac{1}{2}$ inch.

No. 2900, BRONZE METAL, DOUBLE STEEL, BUSHED AT EVERY JOINT

Size.....	3 x 3	$3\frac{1}{2} \times 3\frac{1}{2}$	4 x 4	$4\frac{1}{2} \times 4\frac{1}{2}$	5 x 5	$5\frac{1}{2} \times 5\frac{1}{2}$	6 x 6 inch.
Per pair.....	\$1.70	2.00	2.50	3.20	3.80	4.50	5.50

No. 3900, AMBER BRONZED

Size.....	3 x 3	$3\frac{1}{2} \times 3\frac{1}{2}$	4 x 4	$4\frac{1}{2} \times 4\frac{1}{2}$	5 x 5	$5\frac{1}{2} \times 5\frac{1}{2}$	6 x 6 inch.
Per pair.....	\$0.80	0.40	0.50	0.00	0.75	0.90	1.20

No. 4900, BRONZE-PLATED (OR No. 10 FINISH)

Size.....	3 x 3	$3\frac{1}{2} \times 3\frac{1}{2}$	4 x 4	$4\frac{1}{2} \times 4\frac{1}{2}$	5 x 5	$5\frac{1}{2} \times 5\frac{1}{2}$	6 x 6 inch.
Per pair.....	\$0.60	0.70	0.80	0.90	1.10	1.30	1.00

In ordering Bronze Metal, state Finish desired.

One pair in a box, with Screws.

5 x 5 inch.
5.50

5 x 5 inch.
7.00

SHOWCASE SPRING HINGES

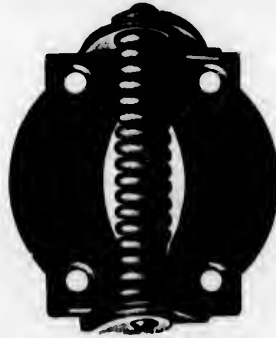

Full size cut.

No. 1—	Wrought Steel, with Brass Springs.....	per doz. pair	\$2.00
“ 6—	“ Brass “ “	“ “	5.00

One dozen pair in a box.

ACME SPRING HINGES

FOR SCREEN DOORS

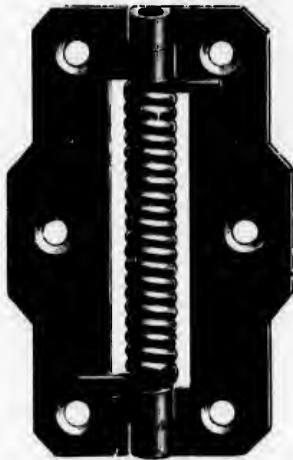

No. 2

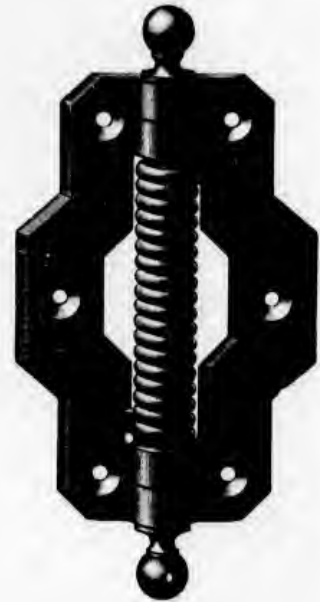

No. 103

SINGLE ACTING

No. 2—	2½ inch Wrought Steel, Amber Bronzed, with Brass Springs.....	per doz. pair	\$2.00
“ 702—	2½ “ “ Brass, with Brass Springs.....	“ “	4.00
“ 103—	3 “ “ Steel, Amber Bronzed, with Brass Springs and Brass Ball Tips.....	“ “	4.70
“ 1703—	3 “ “ Brass, with Brass Springs and Brass Ball Tips	“ “	7.20

DOUBLE ACTING

No. 13—	Wrought Steel, Amber Bronzed, with Brass Springs, without Tips, 3 inch.....	per doz. pair	\$ 7.00
“ 1713—	“ Brass, with Brass Springs and Brass Ball Tips, 3 inch.....	“ “	13.00

Without Tips, one dozen; with Tips, half-dozen pair in a box.

SCREEN DOOR HINGES

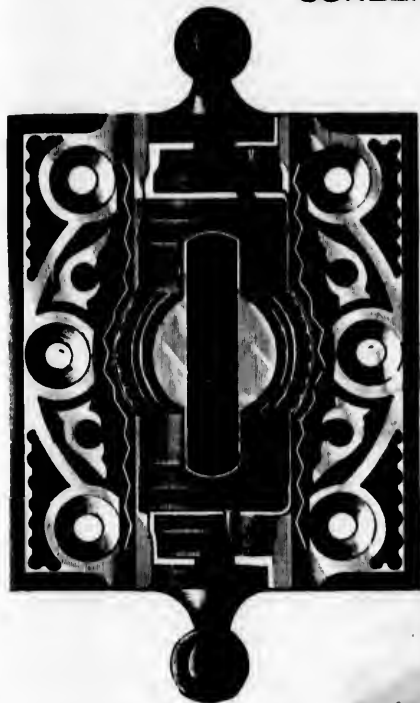

No. 5, full size cut.

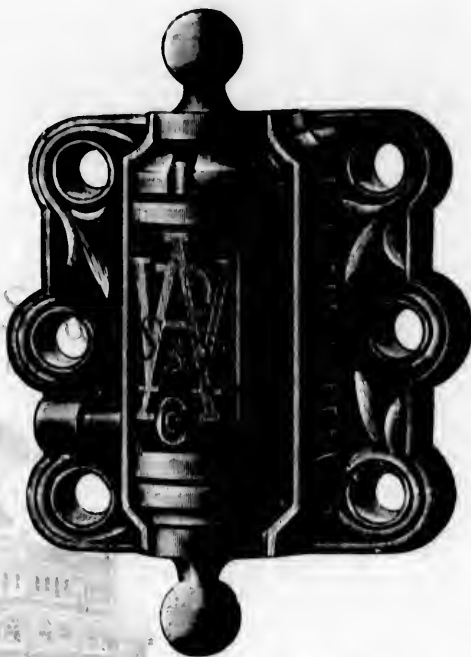

Nos. 20 and 120, full size cut.

No. 5 —Samson, Amber Bronzed, Hold Back	per doz. pair	\$2.35
20 —Arcade, Japanned, Hold Back	“ “	1.60
120 — “ Antique Copper Bronzed, Hold Back	“ “	3.50

Half-dozen pair in a box.



No. 10. MATCHLESS

Hold Back.

2 1/2 x 3 1/2 inch, Japanned.....per doz. pair \$1.65

One dozen pair in a box.

pair \$2.00
“ 5.00

pair \$2.00
“ 4.00
“ 4.70
“ 7.20

pair \$ 7.00
“ 13.60

SCREEN DOOR HINGES

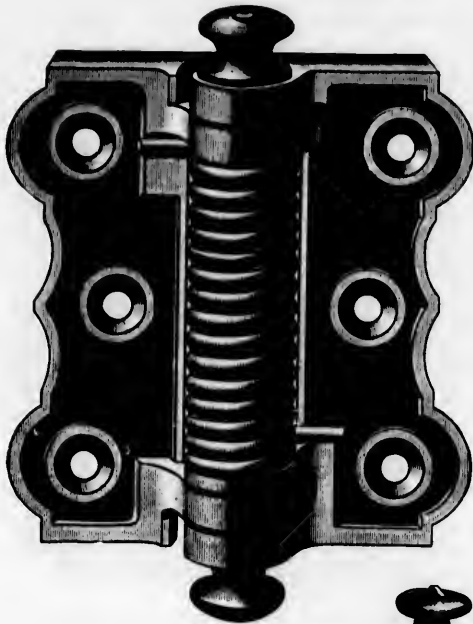

No. 165

JAPANNED, COPPERED SPRINGS

3 inch..... per doz. pair \$2.00

Half-dozen pair in a box.

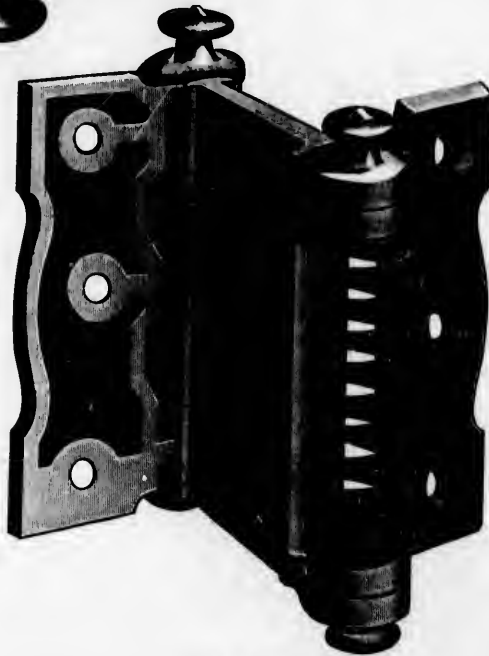

DOUBLE ACTING

No. 1165—3 inch, Japanned, Coppered Springs, for 1 and 1½ Doors..... per doz. pair \$5.00
 " 50—3 inch, all Japanned, for 1 and 1½ Doors..... " " 4.00

Half-dozen pair in a box.

DOUBLE-ACTING SPRING HINGES

"CARTLAND'S"

Nos. 5753 and 5754, with regulating Capstan.

ALL IRON, JAPANED

Size.....	3	3½	4	4½	5	6 in.
For Doors.....	1 to 1½	1½ to 1¾	1¾ to 1½	1½ to 1½	2	2½ "
No. 5753—Spring Hinge, each	\$1.05	1.25	1.35	1.70	1.95	2.40
" 5753—Sham " " "	0.50	0.60	0.60	1.00	1.10	1.20

ALL BRASS

Size.....	3	3½	4	5	6	7 in.
For Doors.....	1 to 1½	1½ to 1¾	1½ to 1½	2	2½	2½ "
No. 5754—Spring Hinge, each	\$1.05	2.05	2.00	3.35	3.00	5.30
" 5754—Sham " " "	0.80	0.95	1.10	1.50	1.70

Nos. 5353 and 5354 same list as 5753 and 5754.

Nos. 5353 and 5354 are without Capstan.



Nos. 5753 and 5754, 3 inch.



OXFORD DOUBLE-ACTING HINGE

OXFORD DOUBLE-ACTING SPRING HINGES

Japaned, Ball Tips.

SPRING HINGES

No. 143—For Doors 6×2 feet, ¾ to 1¼ inch.....	per pair	\$2.40
" 144— " 7×2 " 1 to 1½ "	"	3.00
" 145— " 7×2½ " 1 to 1½ "	"	3.70
" 146— " 7×2½ " 1 to 1½ "	"	5.20
" 147— " 8×2½ " 1½ to 1½ "	"	6.70

SHAM HINGES

No. 143B—For Doors 6×2 feet, ¾ to 1¼ inch.....	per pair	1.20
" 144B— " 7×2 " 1 to 1½ "	"	1.50
" 145B— " 7×2½ " 1 to 1½ "	"	1.85
" 146B— " 7×2½ " 1 to 1½ "	"	2.00
" 147B— " 8×2½ " 1½ to 1½ "	"	3.40

One pair in a box, with Screws.

CHICAGO DOUBLE-ACTING SPRING BUTTS

WROUGHT STEEL

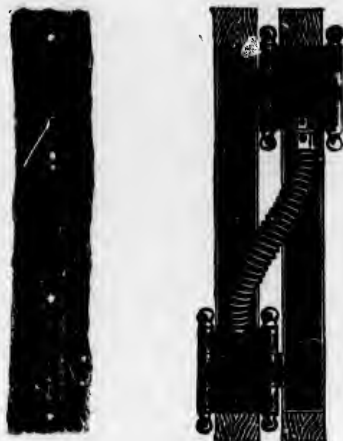

Nos.....	Japanned	Polished	Polished
	Lacq:red Springs.	Nickel-Plated.	Bronze-Plated.
.....	1½	21½	31½
For Doors ¾ to 1 in..per pair	\$1.70	4.20	4.20
“ 1¼ to 1½ “ “	2.10	5.25	5.25
“ 1½ to 1¾ “ “	3.60	7.70	7.70
“ 1¾ to 2 “ “	5.00	10.50	10.50
“ 2¼ to 2½ “ “	0.80	14.00	14.00
“ 2½ to 3¼ “ Cast Metal, Japanned ... No. 1, per pair		14.00	14.00
“ 2½ to 3¼ “ “ Bronze-Plated, “ 31, “		19.00	19.00

When applied to the door, the Spring of this style is concealed when closed. The Spring has a purchase power in closing the door.

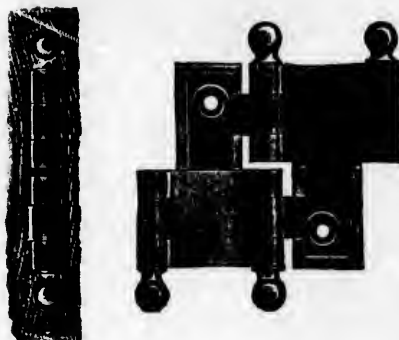

CHICAGO DOUBLE-ACTING BLANK BUTTS

WROUGHT STEEL

Nos.....	Japanned.	Polished	Polished
		Nickel-Plated.	Bronze-Plated.
.....	3½	23½	33½
For Doors ¾ to 1 in..per pair	\$0.85	2.10	2.10
“ 1¼ to 1½ “ “	1.05	2.50	2.50
“ 1½ to 1¾ “ “	1.75	3.85	3.85
“ 1¾ to 2 “ “	2.80	5.25	5.25
“ 2¼ to 2½ “ “	4.90	7.00	7.00

To economize for light doors, put a Spring Butt at the top and a Blank Butt at the bottom of the door. Never use a Blank on outside doors, as it takes the full power of two Springs to hold door against the draft. Always put it below the Spring Butt.

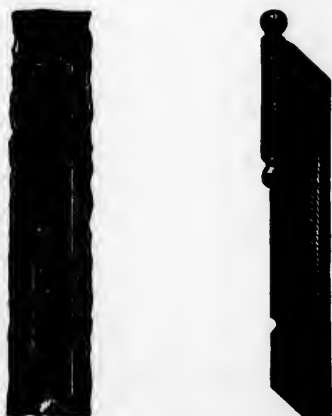

CHICAGO SINGLE-ACTING SPRING BUTTS

CAST METAL

Nos.....	Japanned	Polished	Polished
	Lacq:red Springs.	Nickel-Plated.	Bronze-Plated.
.....	2	22	32
For Doors ¾ to 1¼ in..per pair	\$1.40	2.80	2.80
“ 1¼ to 2 “ “	3.15	6.30	6.30

Common Loose Pin or Loose Joint Butts can be used as Blanks with this.

This style, as in the Double-Acting, requires but little labor or mechanical skill to apply them.

SALOON DOOR HINGES

KEENE'S PATENT DOUBLE-ACTING



FOR DOORS WITH
TOP MOULDING

No. 7—Japanned.....	per pair	\$1.05
" 27—Nickel-Plated.....	"	2.10
" 37—Bronze-Plated.....	"	2.10

This Butt has the advantage of allowing the door to be lifted from its bearings without removing screws or pins.

FIRE ENGINE HOUSE SPRING HINGES

This Hinge throws the door open and is especially adapted to fire engine house doors, as they are held shut and require the hinge to throw the door open when released.

No. 9, JAPANNED

For Stall Doors.....	per pair	\$4.20
For Front Doors.....	"	7.00
" (extra heavy).....	"	9.80

LAVATORY HINGES AND BLANKS

BRASS OR BRONZE

No. 452—Spring.....	per pair	9.10
" 454—Sham.....	"	4.80

In ordering state whether to open or close the door.



THIS OPENS THE DOOR

GATE AND DOOR SPRINGS

PATENT HELICAL DOOR OR GATE SPRINGS

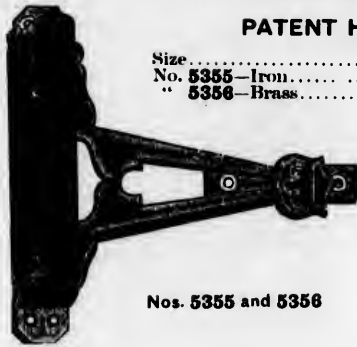

Size.....		6	7	8 inch.
No. 5355—Iron.....	each	\$1.25	1.85	2.25
" 5356—Brass.....	"	1.90

ENGLISH GATE OR TAIL SPRINGS



		No. XXX		
No. XXX.....		16	18	20 inch.
Per dozen.....		\$6.10	6.50	7.00

IMPROVED "ECLIPSE" DOOR SPRINGS



TUSCAN BRONZED

No. 1251—Suitable for Inside Doors.....	each	\$1.80
" 1253—Suitable for Heavy Inside Doors, or Light Outside Doors.....	each	2.30
" 1255—Suitable for Heavy Outside Doors, each		3.00
" 1257—Suitable for Very Heavy Outside Doors.....	each	4.00

EXTRA SPRINGS (SPRINGS ONLY) FOR REPAIRS

Extra Springs for Nos.....	1251	1253	1255	1257
Each.....	\$0.50	0.75	1.00	1.35

The Improved Eclipse has a Flat Spring instead of a Coiled Spring, and is suitable for either Right or Left Hand Doors. The Spring is Adjustable Tension, very compact and powerful, made from Heavy Clock Spring Steel. All parts are interchangeable.

"ECLIPSE" DOOR CHECKS

FOR APPLYING TO DOOR



FOR APPLYING TO CASING



For either Right or Left Hand Doors.

TUSCAN BRONZED

No. 1223—Suitable for Ordinary Doors, Diameter of Cylinder 1½ inch.....	each	\$3.00
" 1225— " Heavy " " 2 "	"	4.00
" 1227— " Very Heavy Doors " " 2½ "	"	6.00

Full Directions in each box.

LIQUID DOOR SPRING AND CHECK

CASE'S IMPROVED

Manufactured by P. & F. Corbin

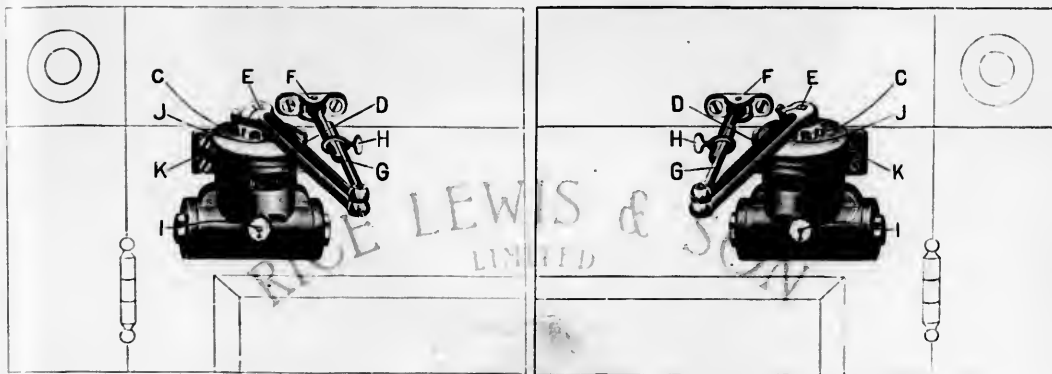

ON RIGHT HAND DOOR

ON LEFT HAND DOOR

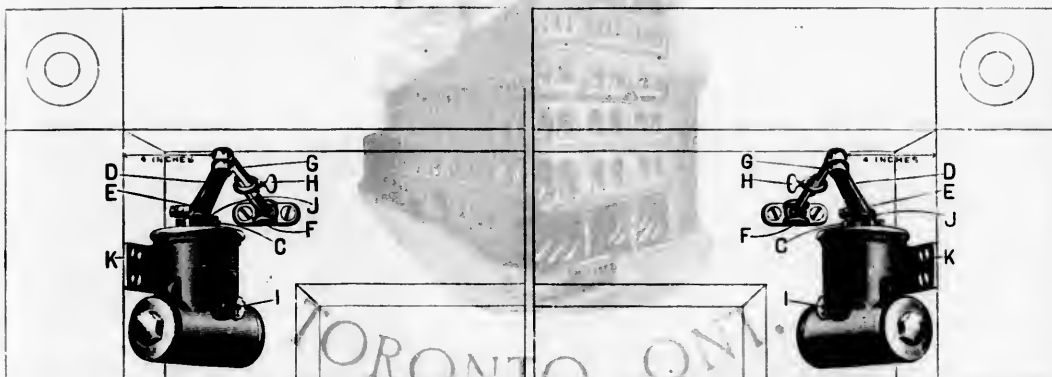

ON LEFT HAND JAMB

ON RIGHT HAND JAMB

COLUMBIAN BRONZED

No. A—For Screen Doors.....	each	\$5.25
" B— " Narrow Inside Doors.....	"	7.00
" C— " Inside Doors not over 3 feet wide, and Outside Doors not over 2½ feet wide.....	"	8.75
" D— " Largest Inside Doors, and Outside Doors not over 3 feet wide.....	"	10.50

One in a box.

Orders for the Improved Door Springs and Checks must state the **Hand** required, as they are made **Right** and **Left Hand**. If the door on which the Spring and Check is to be used is so situated as to receive strong draughts, use one size larger than would be necessary under ordinary conditions.

The most careful attention is given to every detail of their construction, insuring perfection of operation.

COIL DOOR SPRINGS

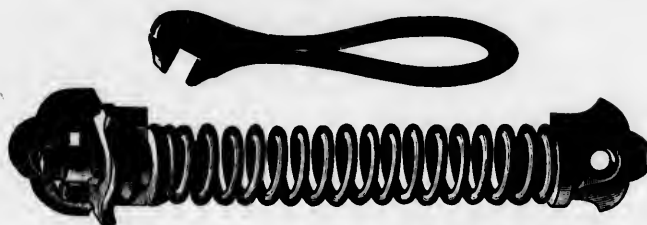

VICTOR

No. 170 — 9 inch, Coppered, for Light Screen Doors.....	per doz.	\$2.00
“ 171 —10 “ “ “ Heavy “		2.50
“ 173 —12 “ “ “ Extra Heavy Screen Doors.....		4.00

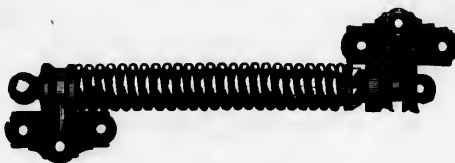

RELIANCE

No. 270 —Laminated Spring, Light.....	per doz.	1.65
“ 270H — “ “ Heavy.....		3.50
“ 271 —Nickeled “ “		5.00

TORREY DOOR SPRINGS

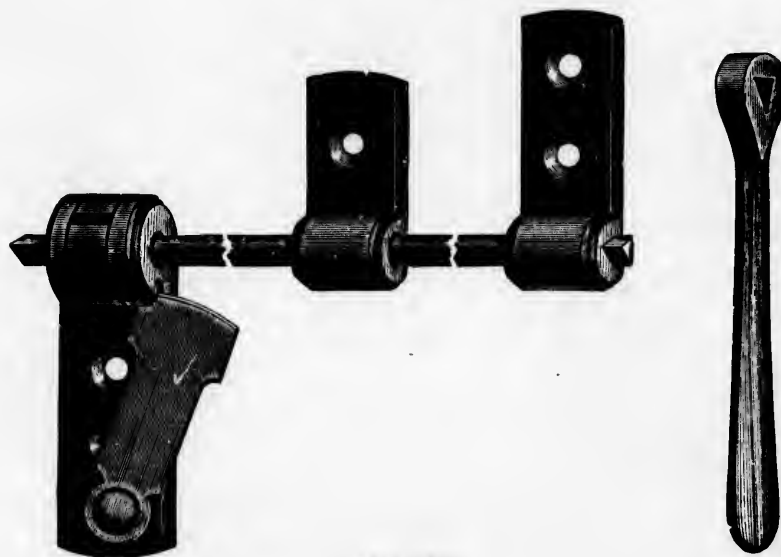

JAPANNED

Torrey, Malleable Iron, Steel Rod, Packed with Screws.....	per doz.	2.60
One dozen in a box.		

BLIND HINGES AND FASTENINGS

PARKER'S

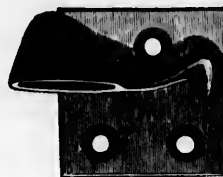
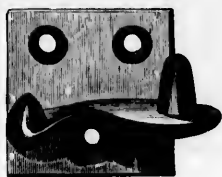

UPPER HINGE

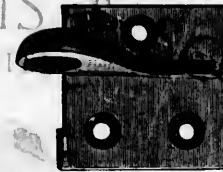
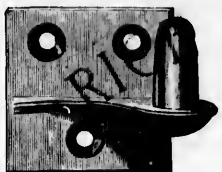

LOWER HINGE

FOR WOOD BUILDINGS

No. 1—	Throws the Blind 1 inch from Casing.....	per doz. sets	\$1.75
" 2—	" " 1½ " " "	"	1.00
" 3—	" " 2 " " "	"	2.00
" 4—	" " 2½ " " "	"	2.15

One-half dozen sets in a package.

FOR BRICK BUILDINGS

No. 5—	Throws the Blind 3 inches from Casing.....	per doz. sets	2.05
" 6—	" " 3½ " " "	"	2.75
" 7—	" " 4 " " "	"	3.15
" 8—	" " 4½ " " "	"	3.50
" 9—	" " 5 " " "	"	4.00
" 10—	" " 5½ " " "	"	4.50
" 11—	" " 6 " " "	"	5.15

One-third dozen sets in a package.

EUREKA BLIND HINGES

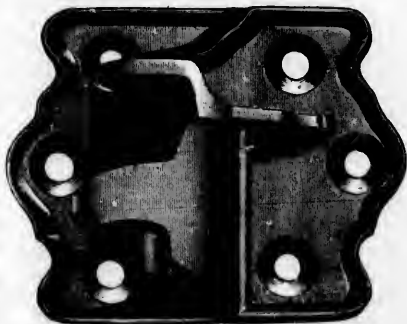

No. 10—	For Wood, throws Blind 1¼ inch from Casing.	
	Per dozen sets	1.36
" 30—	For Brick, throws Blind 3¼ inches from Casing.	
	Per dozen sets.....	2.00
" 50—	For Brick, throws Blind 4¼ inches from Casing.	
	Per dozen sets.....	4.30

One-half dozen sets in a box.

doz. \$2.00
" 2.50
" 4.00

doz. 1.65
" 3.50
" 5.00

oz. 2.60

WROUGHT LIGHT STRAP HINGES



Size, length of each Leaf.....	3	4	5	6	8	10 inch.
Per dozen pair.....	\$1.00	1.20	1.40	1.70	2.50	3.50

WROUGHT HEAVY STRAP HINGES



Size, length of each Leaf.....	4	5	6	8	10	12	14 inch.
*Weight..... per doz. pair	14	18	27	37	54	72	100 lbs.
Price..... per lb.	\$0.06½	0.06½	0.05½	0.05½	0.05½	0.05½	0.05½

WROUGHT LIGHT T HINGES



Size, length of Strap.....	3	4	5	6	8	10 inch.
Per dozen pair.....	\$1.00	1.10	1.30	1.50	1.80	2.40

WROUGHT HEAVY T HINGES



Size, length of Strap.....	4	5	6	8	10	12	14 inch.
*Weight..... per doz. pair	13	18	19	23	45	61	75 lbs.
Price..... per lb.	\$0.07	0.07	0.06½	0.05½	0.05½	0.05½	0.05½

*NOTE—Weights given are only approximate.

HEAVY STRAP HINGES

CORRUGATED STEEL

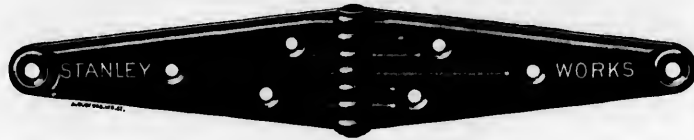

No. 935

Size, length of each Leaf	4	5	6	8	10 inch.
" of Screw.....Nos.	9	10	11	12	14
No. 935..... per doz. pair	\$1.70	2.30	3.25	5.20	7.50

10 inch.
3.50

14 inch.
100 lbs.
0.05½

EXTRA HEAVY T HINGES

CORRUGATED STEEL



No. 937

Size, length of Strap.....	4	5	6	8	10 inch.
" of Screw.....Nos.	10	10	11	13	14
No. 937..... per doz. pair	\$2.00	2.75	3.00	6.00	8.00

10 inch.
2.40

14 inch.
75 lbs.
0.05½

These Hinges are made on a new principle and have many points of superiority over the old-style Hinges.

The Corrugations about the Joints greatly increase the strength of the Hinge, at the same time rendering it impossible for it to bind upon the pin, no matter how rusty it may get. At the same time they are somewhat lighter than corresponding sizes of the regular Heavy Strap and Extra Heavy T Hinges, thus saving unnecessary expense for freight and making them easier to handle.

CRATE HINGES AND HASPS

WROUGHT STEEL



RICE LEWIS
LIMITED
SON

No. 921, LIGHT HINGE AND HASP

No. 12

No. 1, DELAWARE

No. 921—Light Crate Hinges and Hasps, 2½ inch (12 Hasps, 24 Hinges).....	per doz. sets	\$0.80
" 12—Hinge Hasps (cut half size).....	per single doz.	0.00
" 1—Delaware Hasps " ".....	" "	0.50

One dozen in a box.

HASPS AND STAPLES



No. 20, WROUGHT STEEL

Size	4	5	6	7	8	9	10	12 inch.	
No. 20.....	per doz.	\$0.84	0.90	1.00	1.10	1.30	1.70	2.00	2.00

One dozen in a box.

HASPS, WITH HOOK AND STAPLES

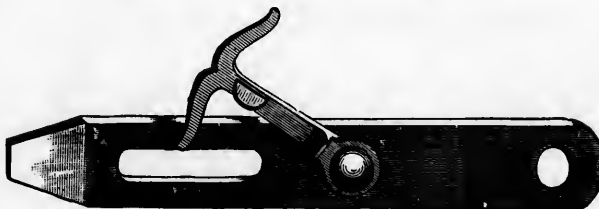

No. 30, WROUGHT STEEL

Size	6	7	8	10	12 inch.	
No. 30.....	per doz.	\$1.40	1.60	1.80	2.50	3.84

One dozen in a box.

10 inch.
41 lbs.
0.07

30 inch.
185 lbs.
0.05

single doz. \$6.00
" 0.60
" 7.75

8 inch.
10
3.50

WROUGHT BRASS HINGE HASPS

Full size cuts.

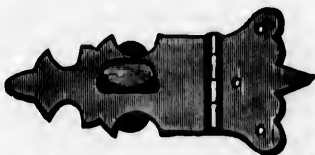
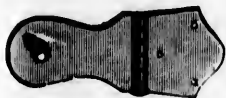

No. 350—Nickel-Plated..per doz. \$1.50 | No. 351—Brassper doz. \$2.00 | No. 350—Brass.....per doz. \$1.00

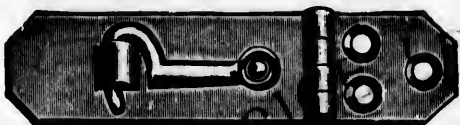

No. 340—Brass.....per doz. \$1.00 | No. 304—Brass.....per doz. \$1.40

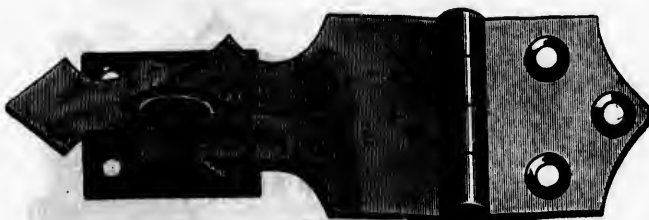

No. 302—Brass.....per doz. \$1.00 | No. 303—Brass.....per doz. \$4.00

BRONZED WROUGHT STEEL LIGHT BASKET HASPS



2 inch.

No. 349—2 inch.....per single doz., with Screws \$0.80
 " 349—2½ "per single doz., with Screws 0.90

WROUGHT STAPLES



Length.....	1	1 1/4	1 1/2	1 3/4	2	2 1/4	2 1/2	3	3 1/2	4 inch.
No. 5.....per gross	\$1.20	1.20	1.25	1.50	1.70	2.00	2.35	3.20	3.70	5.25

1 to 2 1/4 inch, one gross in a box; 3 to 4 inch, half gross.

POULTRY NETTING STAPLES



GALVANIZED

FENCE STAPLES



GALVANIZED

No. 75—3/4 and 1/2 inch.....per lb.	\$0.10		No. 80—1 1/4, 1 1/2 and 2 inch.....per lb.	\$0.06
-------------------------------------	--------	--	--	--------

Poultry Netting Staples in 10 lb. boxes. Fence Staples, 100 lb. boxes.

BARBED BLIND AND BED STAPLES

STEEL COPPERED

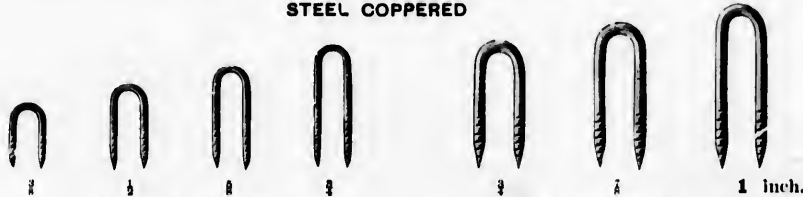

BLIND STAPLES

BED STAPLES

Size.....	3/8	1/2	5/8	3/4	7/8	1 inch.
Blind Staples.....per lb.	\$0.10	0.14	0.14	0.14	0.11	0.11
Bed Staples.....	0.11	0.11	0.11

In 10 lb. boxes.

FLAT STEEL ROUND CROWN STAPLES



These Staples are used principally for Electrical purposes.

Coppered, Sharp Pointed.....	1/2	5/8	3/4	7/8	1	1 1/4	1 1/2	1 3/4 inch.
Per lb.....	\$0.10	0.10	0.10	0.10	0.14	0.14	0.14	0.14



PLAIN BARREL STAPLE



BASKET FASTENER



PATENT BARREL STAPLE

Barrel or Box Staples, Bright, 3/4 inch long, 3/8 inch wide, Plain.....per lb.	\$0.10
Patent.....	0.11
Basket Fasteners, Coppered Steel Wire Basket Fasteners, in 2 lb. packages.....	0.14

GATE LATCHES

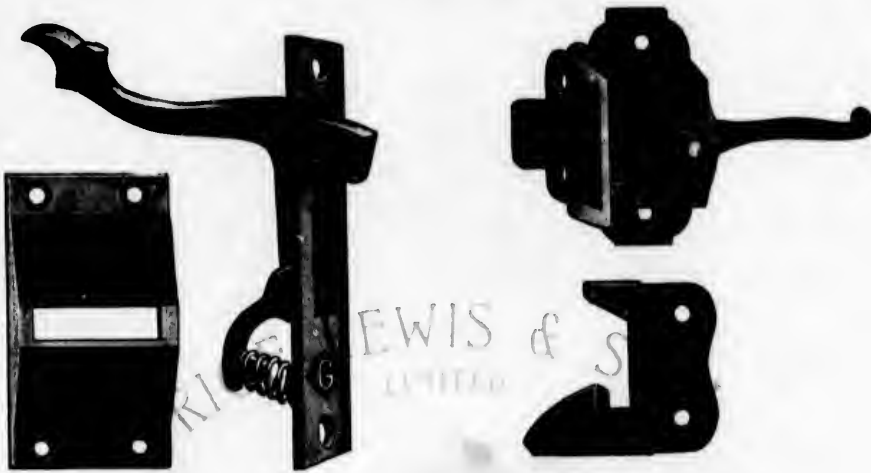

No. 1, half size cut.

SPIRAL SPRING ACTION

For Gates Swinging Both Ways.

No. 8, half size cut.

GRAVITY ACTION

For Gates Swinging One Way.

No. 1—Japanned.....per doz. \$1.70 | No. 8—Japanned.....per doz. \$1.70



No. 2, half size cut.

GRAVITY ACTION

For Gates Swinging One Way.

No. 3, half size cut.

GRAVITY ACTION

For Gates Swinging One Way.

No. 2—Japanned.....per doz. \$1.70 | No. 3—Japanned.....per doz. \$1.70

Half-dozen in a box.

4 inch.
5.25

lb. \$0.06

1 inch.
0.11

1 1/4 inch.
0.14

STAPLE

lb. \$0.10
0.11
0.14

REVERSIBLE GATE HINGES

SELF-CLOSING



UPPER GATE HINGE

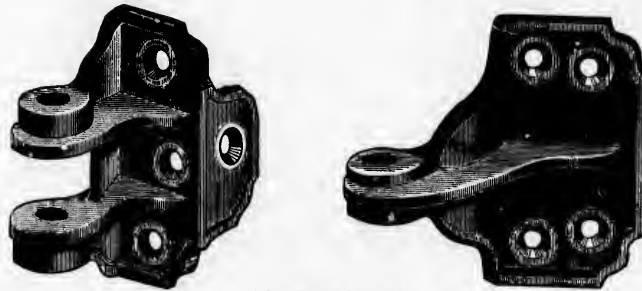

LOWER GATE HINGE

No. 60—Reversible, Swing One Way.....per doz. pair \$2.25

SURFACE GATE HINGES

SELF-CLOSING

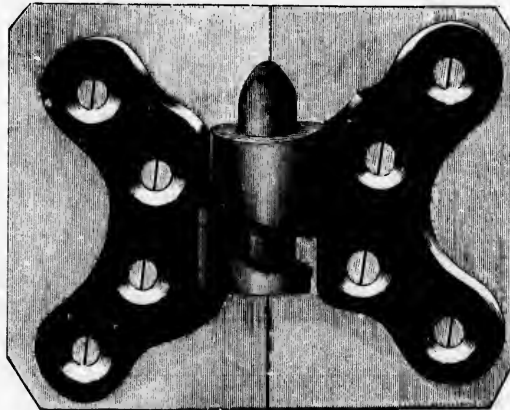

No. 3—Japanned, Swing One Way, half Rights and Lefts in a boxper doz. pair 2.00
Half-dozen pair in a box.

WESTERN GATE HINGES

TO SWING BOTH WAYS

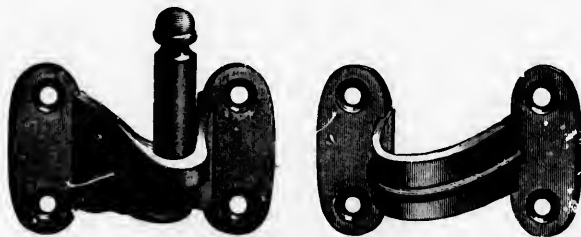

No. 224, half size cut of Upper Hinge.



No. 224, half size cut of Lower Hinge.

No. 224—Gate Hinges, Self-Closing.....per doz. pair \$3.20

pair \$2.25



No. 244, 1/2 inch diameter, 10 inches over all. Upper Hinge. Wrought Iron.



No. 244, half size cut of Lower Hinge.

No. 244—Gate Hinges, Self-Closing.....per doz. pair 4.40

pair 2.00

Any Gate Latch in this Catalogue will suit these Hinges.

One-sixth dozen pair in a box.

BARN DOOR HANGERS

FOR WOOD TRACK



STEARNS

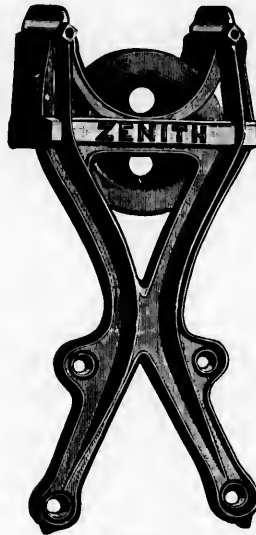

ZENITH



ACME

Stearns Barn Door Hangers, 4 inch	per doz. pair	\$5.40
" " " 5 "	" "	6.75
Zenith " " 4 "	" "	9.00
Acme " " Steel Frame, 4 inch	" "	8.10
" " " 5 "	" "	9.00

FOR IRON TRACK

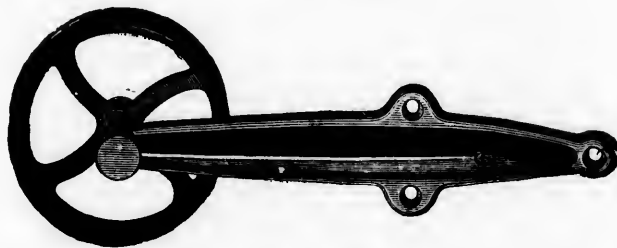

With Grooved Wheel for Half-Round Track.

Size, Diameter of Wheel	4	5	6	inch.
Per dozen pair	\$6.00	7.20	10.80	

BARN DOOR HANGERS

STEEL BARN DOOR HANGERS

COVERED

For Flat Steel Track.

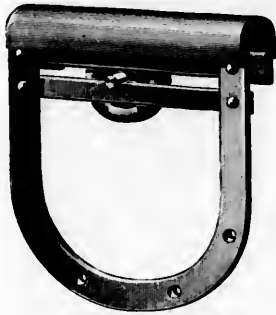

Nos. 11 to 12

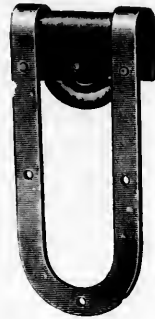

No. 25

- | | |
|--|---------|
| No. 11—For Doors, to Slide 5 feet....per doz. pair | \$15.00 |
| “ 11½— “ “ 10 “ “ | 18.00 |
| “ 12—(Extra Heavy Doors), 10 feet. “ | 22.00 |
| “ 25—Light Pattern, Endless Run, “ | 10.00 |
| “ 30— “ with Roller Bearings “ | 13.00 |

RICE LEWIS & SON
LIMITED
TORONTO, ONT.

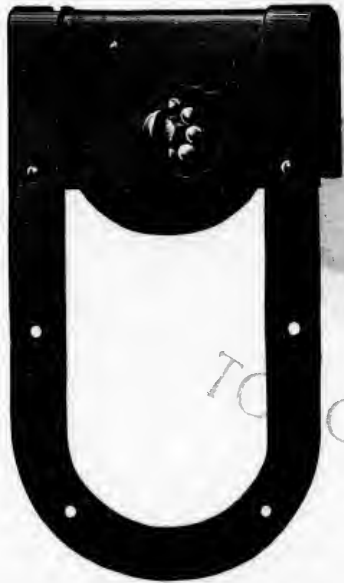

No. 50



No. 143

- | | |
|---|---------|
| No. 50—Heavy, with Roller Bearings, Endless Run.....per doz. pair | \$18.00 |
| “ 143—O.K., for Light Doors, Roller Bearings, Endless Run | “ 12.00 |

pair \$5.40
“ 6.75
“ 9.90
“ 8.10
“ 9.00

6 inch.
10.80

BARN AND FIRE DOOR HANGERS

WILCOX TROLLEY ROLLER BEARINGS

No. 124

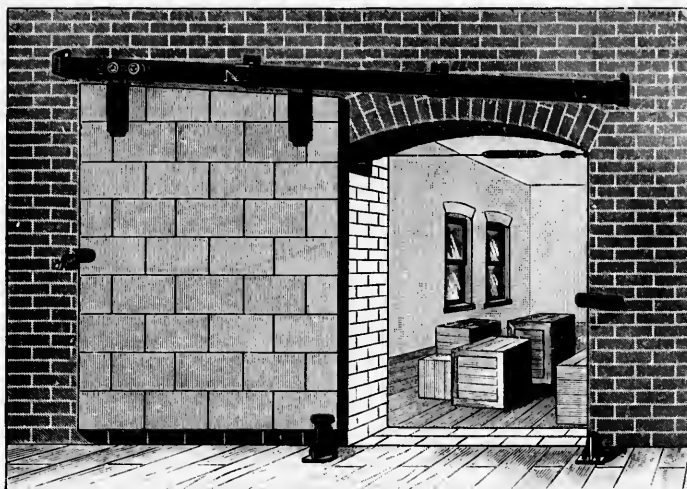

SHOWING HANGERS IN OPERATION

No. 124—One Pair Hangers	per pair	\$4.00
Extra Track Brackets.....	each	0.25
Trolley Track.....	per foot	0.30

A pair of Hangers consists of: 2 Hangers and Carriers, 1 Right End Bracket, 1 Left End Bracket, 1 Centre Bracket, complete with Wood Screws for Hangers and Lag Screws for Brackets. Hangers and Track sold separately; Hangers having lateral adjustment, and are suitable for doors $2\frac{1}{4}$ inches thick. For Self-closing Fire Doors use the above hangers and track and put up track on incline $\frac{1}{4}$ inch to the foot; when used for Double Doors a centre overhead stop is furnished in connection with brackets.

When ordering always give thickness of door, the exact widths of openings and state whether for double or single doors.

AUTOMATIC LATCH AND FIXTURES

No. 127

For Self-Closing Fire Doors, as shown in operation above.

No. 127—One Set Fixtures, complete	per set	\$10.80
--	---------	---------

A set of Fixtures consists of: 2 Wall Stops, 1 Floor Stop, 1 Guide Roller, 1 Automatic Latch, 1 Steel Spring, 1 Steel Plate, 2 half-inch Expansion Bolts, 1 Expansion Screw Eye, 1 Fusible Link, 2 Link Hooks, 10 to 15 feet Sash Cord, 1 Cord Tightener.

This Latch and Fixtures can be used in connection with fire shutters. When ordering give thickness of wall, and state whether inner sides of opening are of covered wood, brick or stone.

PARLOR DOOR HANGERS

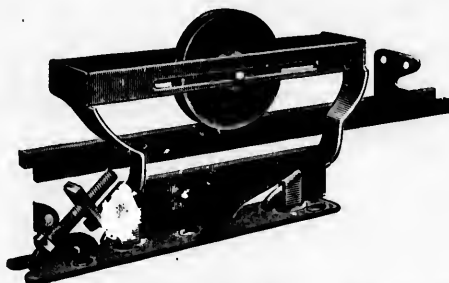

WILCOX-RICHARD'S

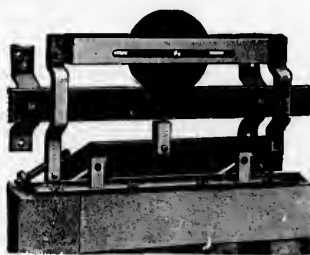

LANE'S STANDARD

FOR DOUBLE DOORS

Each Door to Slide 4 feet or less.

No. 113—Wilcox-Richard's, 4 Hangers, complete with 14 feet of Steel Track	per set	\$6.00
" 114—Lane's Standard, 4 " " " 14 " " "	"	6.00
" 313—Canadian-Richard's, 4 " " " 28 " " Hardwood Track	"	3.75

FOR SINGLE DOORS

To Slide 4 feet or less.

No. 213—Wilcox-Richard's, 2 Hangers, complete with 8 feet of Steel Track	per set	3.00
" 214—Lane's Standard, 2 " " " 8 " " "	"	3.00

LANE'S BALL-BEARING PARLOR DOOR HANGERS

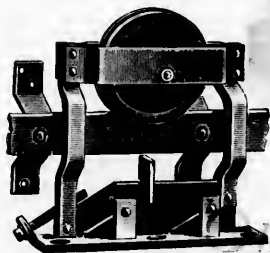

BALL-BEARING



NEW MODEL (ROLLER BEARINGS)

No. 110—Lane's Ball-Bearing, 4 Hangers, complete with 14 feet of Track	per set	7.50
" 210— " " 2 " " " 8 " " "	"	3.75
" 111— " " New Model, 4 " " " 14 " " "	"	5.50
" 211— " " " 2 " " " 8 " " "	"	2.75

In the New Model, both Hangers of a pair are alike, and consequently no Rights or Lefts.



This illustrates the manner in which the Hangers are applied to the Door.

HOUSE DOOR HANGERS

WILCOX TROLLEY BALL-BEARING

No. 119

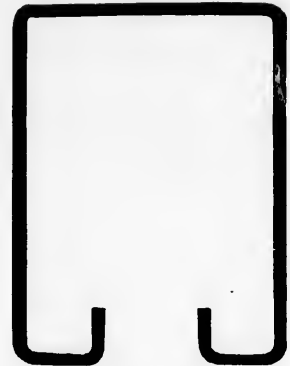
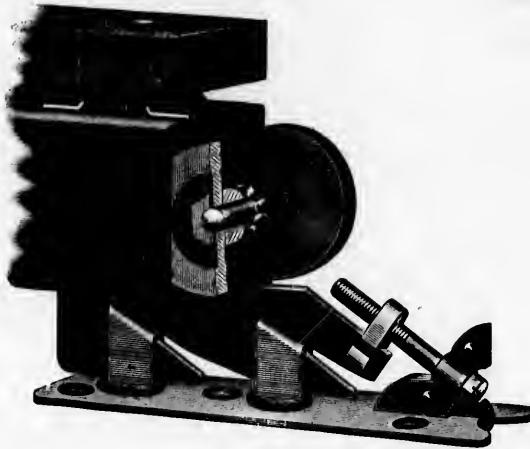

SECTION OF TRACK

No. 119—For Double Doors, 4 to 6½ ft. Opening.....	per set	\$6.00
“ 219— “ “ 7 to 8 “ “	“	7.00
Half Sets, half price of Full Sets.		
Track.....	per ft.	0.25

Furnished in any length to 10 ft., without Joint.

This Hanger is made of Steel, the Wheels Vuleanized Fibre, are noiseless, and have Bicycle Ball Bearings. They are shipped with the Track attached to a Wooden Header, ready to fix to the Heading Timber.

“NEW ERA” HOUSE DOOR HANGER

ROLLER BEARINGS

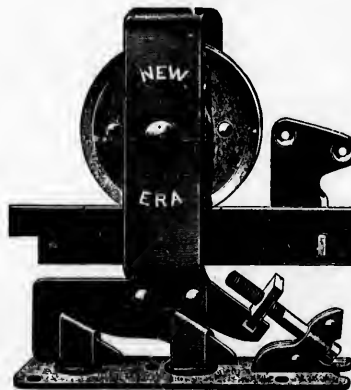

No. 117, SINGLE TRACK

No. 117—For Double Doors, Full Sets, 4 Hangers, complete with 14 ft. Track.....	per set	\$6.00
“ 217—For Single Doors, Half Sets, 2 Hangers, complete with 8 ft. Track.....	per half set	3.00
Track.....	per 100 ft.	8.65

STEEL TRACK

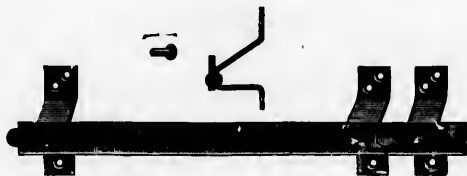

Lane's O.N.T. Steel Track

Wilcox Steel Hanger Track, in 4, 6, 8 and 10 ft. lengths	per 100 ft.	\$8.65
Lane's O.N.T. Steel " " " "		0.15

CAST IRON TRACK



For Half-Round Groove Hangers.



For Square Groove Hangers.

No. 1—Half-Round, in 2 ft. lengths	per ft.	0.08
" 2—Square " "		0.07

BARN DOOR STAY ROLLERS



No. 153

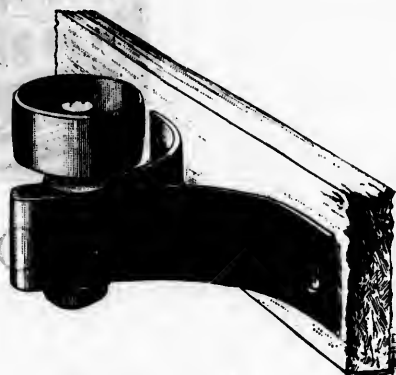

No. 154



No. 157

No. 153—Wilcox Steel Adjustable and Reversible Barn Door Stay Roller	per doz.	2.70
" 154—Lane's " "		3.15
" 157—For Outside Sliding Doors		1.50

AXLE PULLEYS

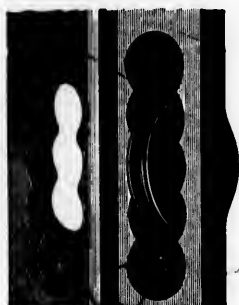

"THE COMMON SENSE"

"EMPIRE"

No. 1—Palmer's "Common Sense," all Iron, with Wrought Iron Axle, 2 inch Wheel..... per doz. \$0.50
 " 2—"Empire," all Iron, with Wrought Iron Axle, 2 inch Wheel..... " 0.80



COMMON PATTERN

No. 3—Common Pattern, all Iron, Wrought Iron Axle, 1½ inch Wheel..... per doz. 0.42
 " 4— " " " " " 2 " " " 0.46
 " 5— " " " " " 2½ " " " 0.60

et (4) \$0.75
0.90

doz. 3.60
1.80
3.25

ft. 0.10
0.10

AXLE PULLEYS



No. 22



No. 32

No. 22	— All Iron, Panel Face, 2 inch Wheels	per doz.	\$0.96
" 32	— " Amber Bronzed Face, 2½ inch Turned Wheels	"	1.70

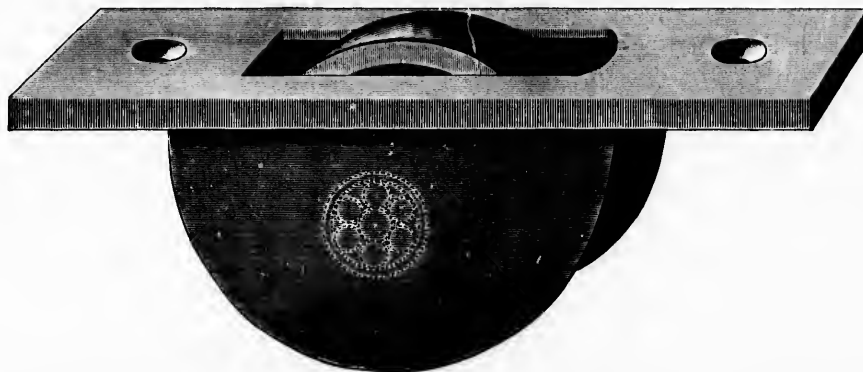

No. 626

Anti-Friction Roller Bearings.

ALL IRON, PAINTED FACE

No. 626	— Square End, with 2½ inch Turned Wheels	per doz.	2.50
" 626R	— Round " " 2½ " "	"	2.85

BRONZE METAL FACE

No. 630	— Square End, with 3 inch Turned Brass Wheels	per doz.	12.00
---------	---	----------	-------

PULLMAN SASH BALANCES



Adapted to old as well as new work. Can be used with or without Pockets or Box Frames or in any style of window.

						Per set.
No. 3	—	Weight of Sash,	10 to 11 lbs.;	Height of Sash,	46 inches.	\$2.80
" 4	—	"	12 to 13 "	"	46 "	3.10
" 5	—	"	14 to 15 "	"	46 "	3.40
" 6	—	"	16 to 17 "	"	46 "	3.70
" 7	—	"	18 to 19 "	"	46 "	4.00
" 8	—	"	20 to 21 "	"	46 "	4.70
" 9	—	"	22 to 23 "	"	46 "	5.00

DUMB WAITER PULLEYS



Full size.

No. 40—3 inch Iron Wheel, Heavy, Face Measure $1\frac{1}{4} \times 6$ inches per doz. 3.30

doz. \$0.96
" 1.70

doz. 2.50
" 2.85

doz. 12.00

DUMB WAITERS

THE "EASY"

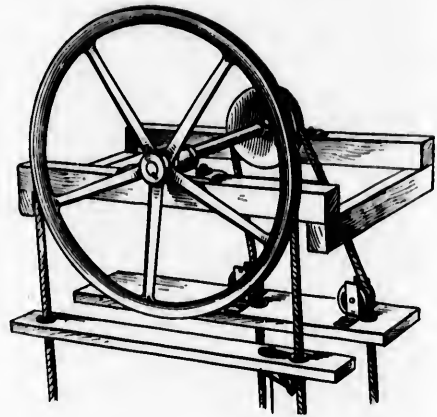
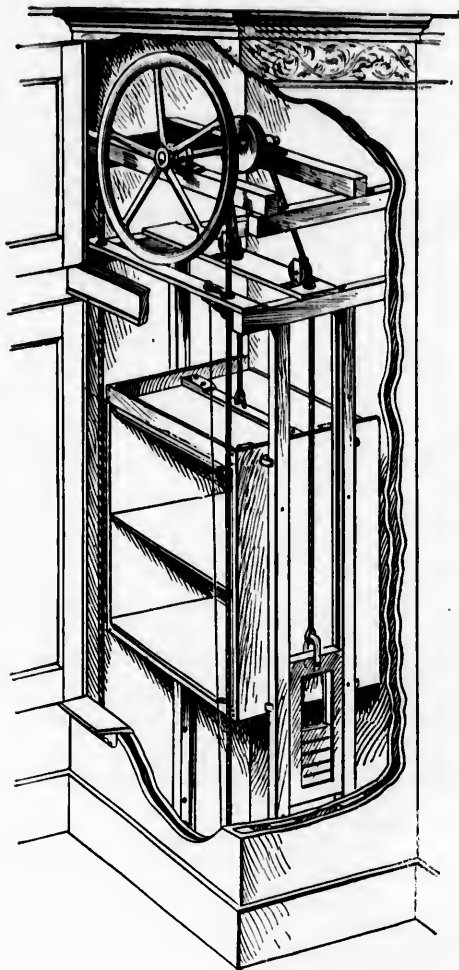

One machine complete in box with full directions for erecting.

Each box contains:—

- 1 Hand Wheel, 20 inches diameter.
- 1 Holst Wheel.
- 1 Steel Shaft, 18 inches long.
- 2 Babbitted Bearings.
- 1 Spring Check.
- 2 Pulleys.
- 4 Rope Leaders.
- 1 Staple for top of Car.
- 1 Coupling for Hand Rope.

Machine, as enumerated above	\$22.50
Flat Adjustable Weight as shown in cut	per lb. 0.06

This machine will run perfectly for any height, and is so simple that any mechanic can erect. The weight can be put at either side, or at back by use of an extra pulley.

HORIZONTAL RIM KNOB LATCHES

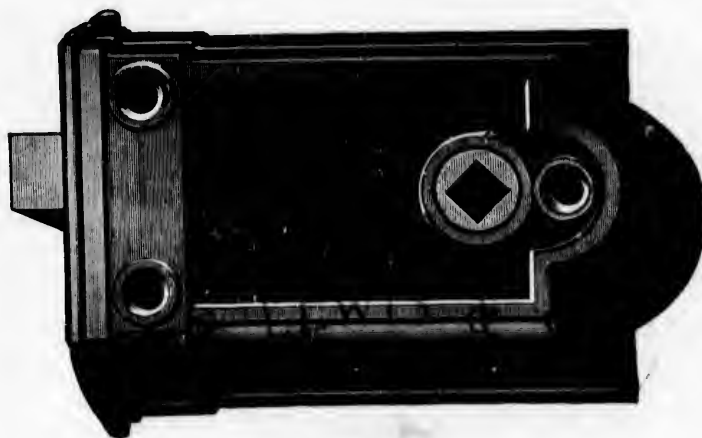

Full size cut.

Peterboro'. Gurney.

No. 70	R1a—4 x 2½ inch, Iron Bolt	doz.	\$1.00
" 71	R2a—4 x 2½ " Brass "	"	2.80

Half-dozen in a box.

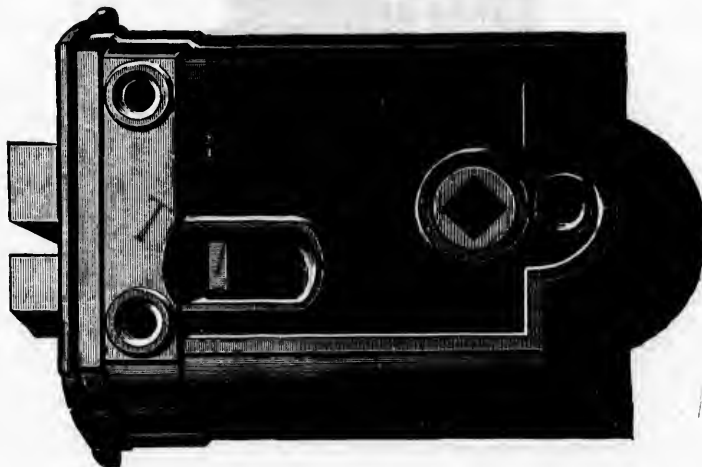

Full size cut.

Peterboro'. Gurney.

No. 75	R10a—3¾ x 2½ inch, Iron Bolt, with Flush Thumb Piece	per doz.	2.50
" 76	R11a—3¾ x 2½ " Brass "	"	3.50

Half-dozen in a box.

HORIZONTAL RIM NIGHT LATCHES

FOR RIGHT OR LEFT HAND DOORS



Full size cut.



Peterboro'. Gurney.
 No. 90 R20a— $3\frac{1}{2}$ x $2\frac{1}{2}$ inch, Iron Bolt, Bronze Metal Turn Knob, 2 Nickel-Plated Steel Keys to each, Japanned Escutcheon per doz. \$6.00
 Half-dozen in a box.

HORIZONTAL TUBULAR RIM NIGHT LATCHES

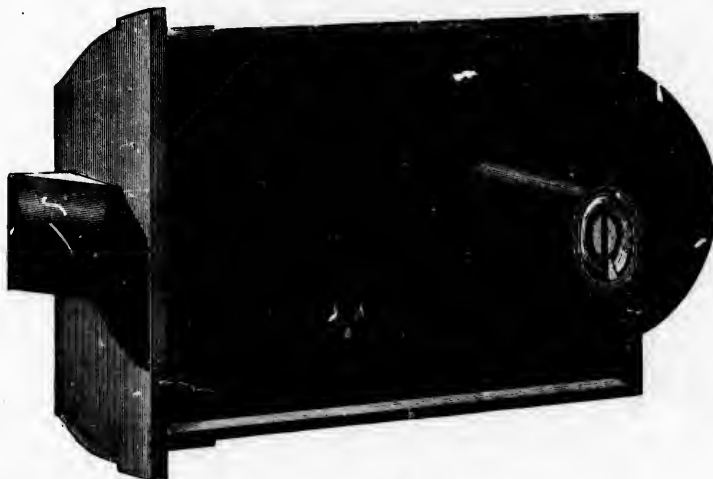

Full size cut.



Peterboro'. Gurney.
 No. 90 R30— $3\frac{1}{2}$ x $2\frac{1}{2}$ inch, Iron Bolt, Bronze Metal Turn Knob and Escutcheon, 2 Nickel-Plated Steel Keys to each, 5 Tumblers per doz. \$12.00
 " 91 R31—Same as No. 90 and R30, with Brass Bolt " 14.00
 Quarter-dozen in a box.

CYLINDER RIM NIGHT LATCH



Full size cut.

With Pin Thimbles, for Doors 1 to 1½ inch.

Peterboro.

No. 100—3½ x 2½ inch, Iron Bolt, Bronze Metal Turn Knob, 2 Nickered Steel Keys, 3 Pin Tumblers. . per doz. \$12.00
 " 101—3½ x 2½ " Bronze Metal Bolt, Bronze Metal Turn Knob, 2 Nickered Steel Keys, 3 Pin Tumblers, per doz. 14.00

WROUGHT STEEL RIM NIGHT LATCH

REVERSIBLE BOLT



Full size cut.

No. 378—3 x 2½ inch, Ivory Black Wrought Steel Case, Bronze Metal Bolt, Knob and Escutcheon, two Nickel-Plated Steel Keys to each, for Doors ½ to 2 inch. per doz. \$11.00
 One in a box.

RIM NIGHT LATCHES

"LINCOLN"

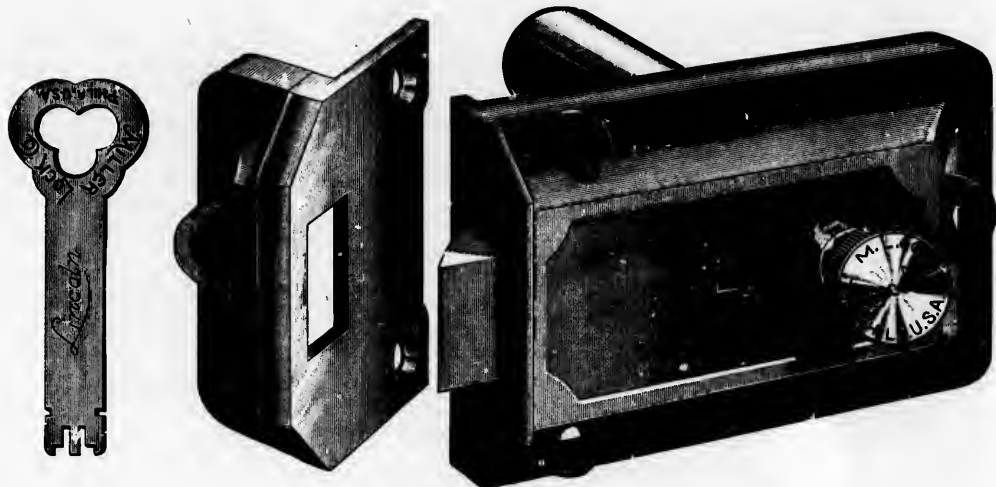

Full size cut.

REVERSIBLE BOLT, TUBULAR PATTERN

- No. 4978— $3\frac{1}{2}$ inch, Iron Case, Bronze Metal Bolt, Knob and Escutcheon, 3 Nickel-Plated Steel Keys, for Doors $\frac{1}{2}$ to 2 inch..... per doz. \$16.50
 " 5978—Same as above, only Bronze Metal throughout..... " 22.50

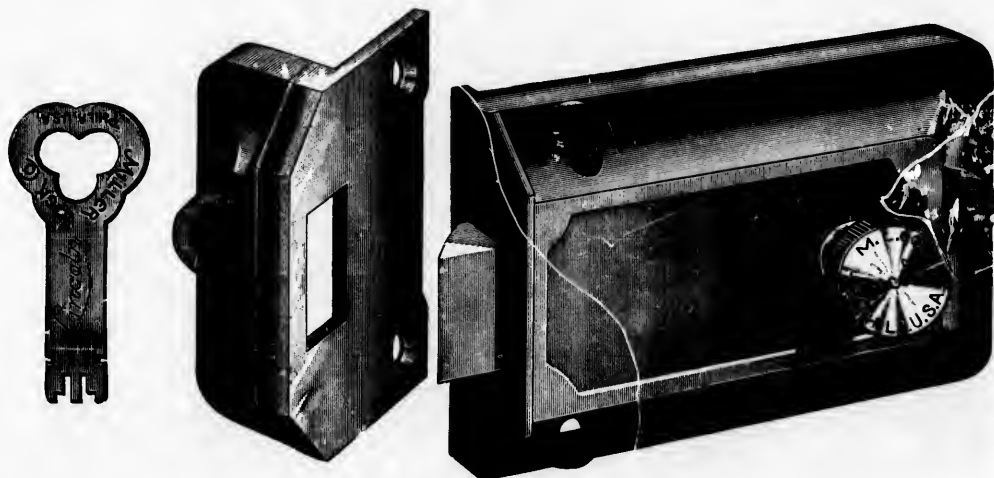

Full size cut.

REVERSIBLE BOLT, CYLINDER PATTERN

- No. 4778— $3\frac{1}{2}$ inch, Iron Case, Bronze Metal Trimmings, 3 Nickel-Plated Steel Keys, for Doors $\frac{1}{2}$ to 2 inch, per doz..... \$21.50

One in a box.

UPRIGHT RIM KNOB LOCKS

FOR RIGHT OR LEFT HAND DOORS

Packed with Screws and Japanned Escutcheon.

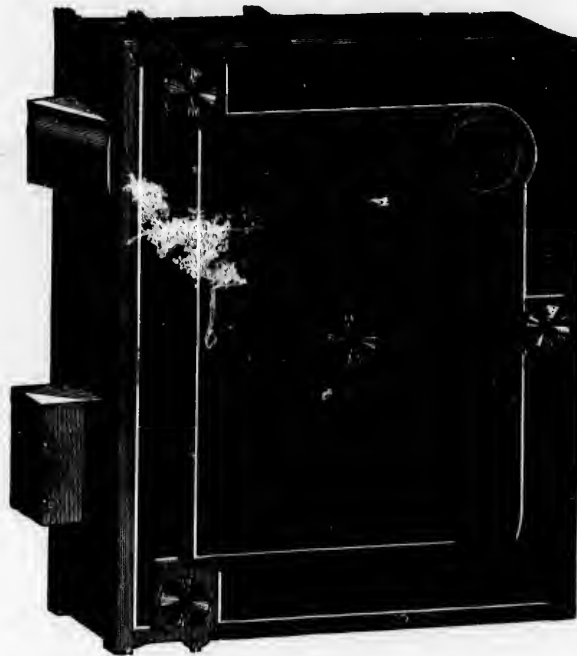

Full size cut.

JAPANNED CASE

To Reverse, remove the Cap.

Peterboro.	Gurney.		
No. 1216	R36a	—4 x 3 inch, Iron Bolts, without Stop, Tinned Keys.....	per doz. \$2.40
" 1221	R41a	—4 x 3 " " with " "	" 2.50
" 1422	—4 x 3 " Iron Bolts, with Stop, Flat Nickeled Steel Key.....	" 2.80
" 1423	—4 x 3 " Brass " " "	" 4.50

Half-dozen in a box.

Peterb
No. 1
" 1
" 1
" 1
" 1

Keep

URPRIGHT RIM KNOB LOCKS

FOR RIGHT OR LEFT HAND DOORS

Packed with Screws and Japanned Escutcheons.

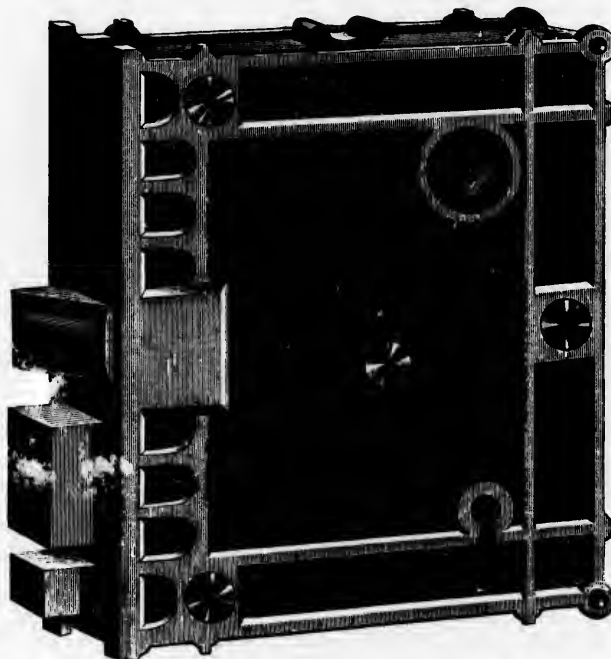

Full size cut of 4½ x 3½ inch.

JAPANNED CASE



To reverse, remove the Cap.

Peterboro.	Gurney.			
No. 1235	R770—4½ x 3½ inch,	3 Iron Bolts,	Tinned Malleable Iron Keys.....	per doz. \$5.50
" 1236	R771—4½ x 3½ "	3 "	Nickel-Plated Steel Keys	" 6.50
" 1237	R772—4½ x 3½ "	3 Brass Bolts,	"	" 8.00

Half-dozen in a box.

Peterboro
No. 1235
" 1236
" 1237
" 1238
" 1239
" 1240
" 1241
" 1242

UPRIGHT RIM KNOB LOCKS

FOR RIGHT OR LEFT HAND DOORS

Packed with Screws and Japanned Escutcheons.

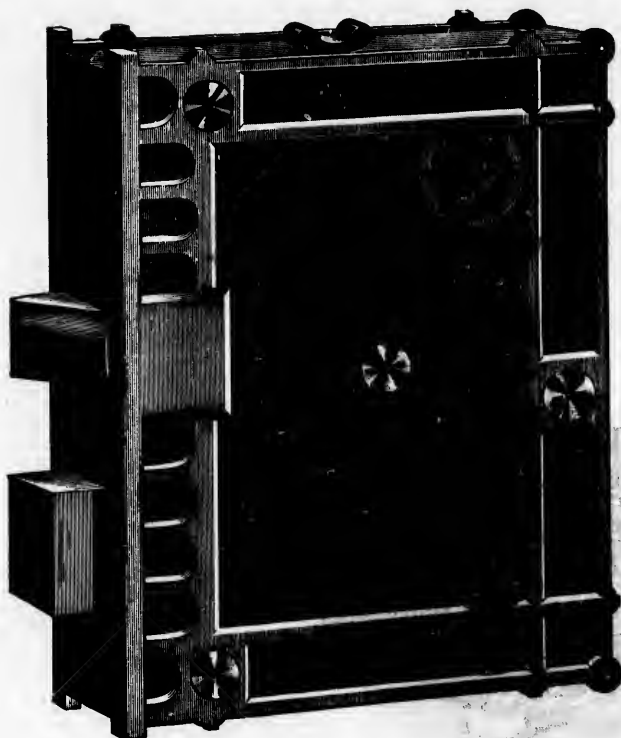

Cut full size of $4\frac{1}{2}$ x $3\frac{1}{2}$.
JAPANNED CASE.

Reverse by Drawing Slide at Back and Turn Latch.

Peterboro'.	Gurney.								
No. 1241	R1100	$4\frac{1}{2}$ x $3\frac{1}{2}$ inch,	2 Iron Bolts,	Nickel Steel Key,	1 Tumbler,	12 Changes	per doz.	\$6.25	
" 1242	R1101	$4\frac{1}{2}$ x $3\frac{1}{2}$	2 Brass	"	"	1 " 12 "	"	7.50	
" 1246	R1111	$4\frac{1}{2}$ x $3\frac{1}{2}$	3 Iron	"	"	1 " 12 "	"	7.00	
" 1247	R1112	$4\frac{1}{2}$ x $3\frac{1}{2}$	3 Brass	"	"	1 " 12 "	"	8.50	
" 1251	R1120	5 x 4	2 Iron	"	"	1 " 12 "	"	9.50	
" 1252	R1121	5 x 4	2 Brass	"	"	1 " 12 "	"	11.00	
" 1261	R1130	5 x 4	3 Iron	"	"	1 " 12 "	"	10.50	
" 1262	R1131	5 x 4	3 Brass	"	"	1 " 12 "	"	12.50	
" 1281	R1137	6 x 4	2 Iron	"	"	1 " 12 "	"	11.50	

Half-dozen in a box.

WROUGHT STEEL RIM KNOB LOCKS

FOR RIGHT OR LEFT HAND DOORS



Set No. 2120

OLD COPPER FINISH

No. 2120—4 x 4 inch, Lock, Knobs and Escutcheon, O. C.	per doz. set	\$16.20
" 1105—4 x 4 " " " only, same style as above, Japanned.....	per doz.	5.70



No. 3800, full size cut.

IVORY BLACK CASE

No. 3800—4 x 3½ inch, Iron Bolts, with Stop, Nickel-Plated Key	per doz.	3.50
" 3804—4 x 3½ " Brass " " "	"	5.70

Size ...
No. 60
" 60.

No. J14
" J14
Lock K

Size ...
No. 154
" 154

For Loc
No. 60
" 60A
" 60A

FRONT DOOR UPRIGHT RIM KNOB LOCKS

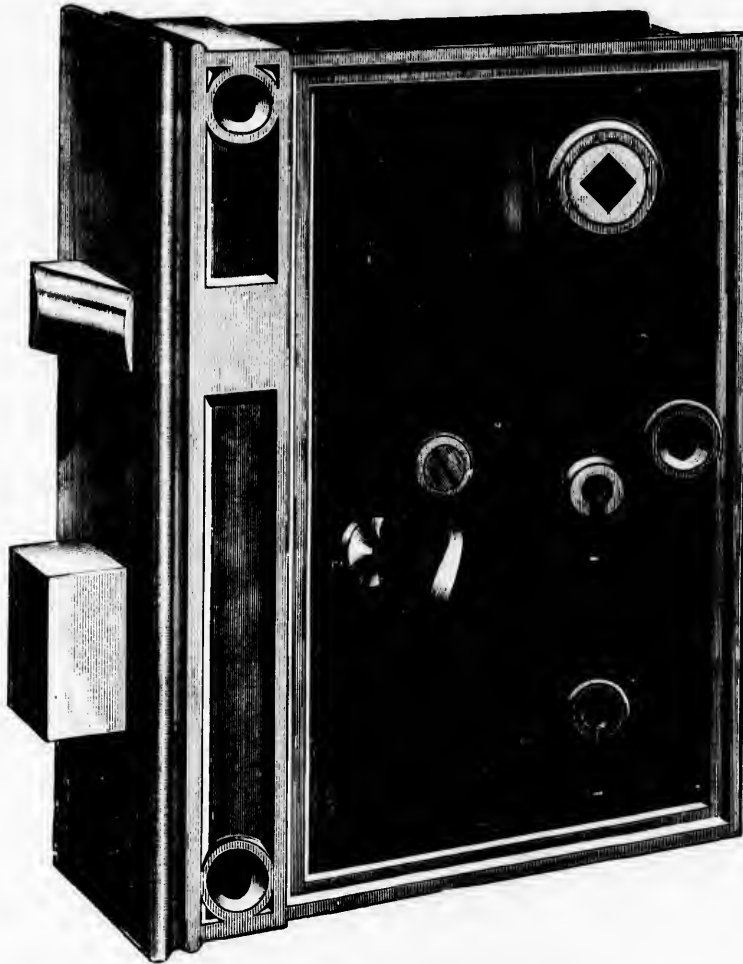

WITH NIGHT WORKS

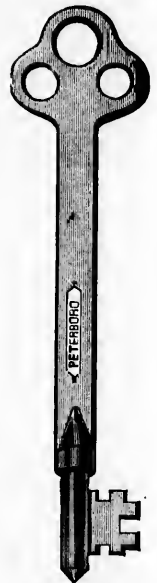

No. 1370. Full size cut.

REVERSIBLE LATCH BOLT



Peterboro.
No. 1270
" 1370

Gurney.

R1140—5 x 4 inch, 2 Iron Bolts, Bronze Metal Turn Knob, 2 Nickeled Steel Night Key-,
1 Steel Tumbler, 1 Nickeled Steel Key for Dead Bolt, 1 Steel Tumbler, 12 Changes
.....—6 x 4 inch, 2 Iron Bolts, Bronze Metal Turn Knob, 2 Nickeled Steel Night Keys,
1 Steel Tumbler, 1 Nickeled Steel Key for Dead Bolt, 1 Steel Tumbler, 12 Changes

Per doz.
\$ 20.00
22.00

WORKS



BRASS MORTISE SHIP LOCKS

Full size cuts.

Furnished with Brass Knobs and Brass Spindles, if desired.



No. 1200—3½ x 3¼ inch, Brass Front, Bolts and Case, Brass Keys per doz.....\$24.00

BRASS RIM SHIP LOCKS

Furnished with Brass Knobs and Brass Spindles, if desired.

No. 1205—4½ x 3¼ inch, Brass Bolt and Case, Brass Key, per doz.....\$24.00

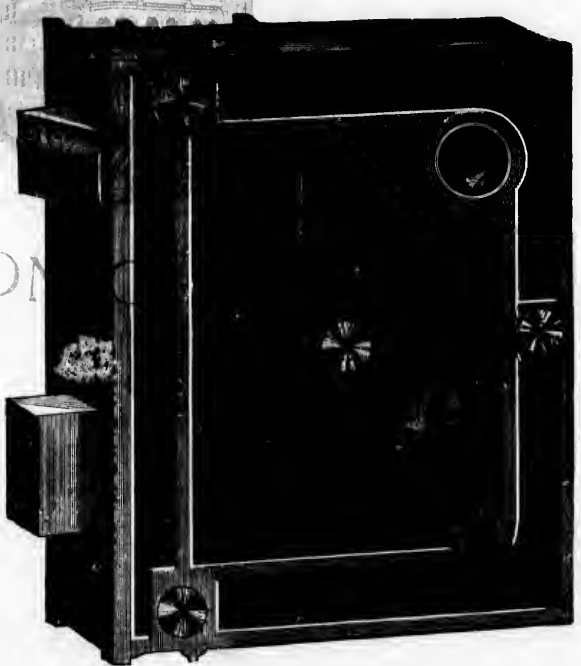
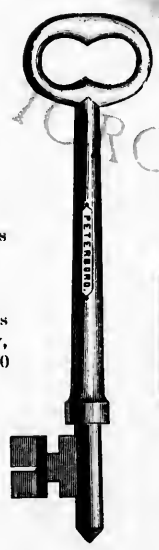

Per doz.
y-
ges \$ 20.00
ys,
ges 22.00

HORIZONTAL RIM DEAD LOCKS

RIGHT OR LEFT HAND

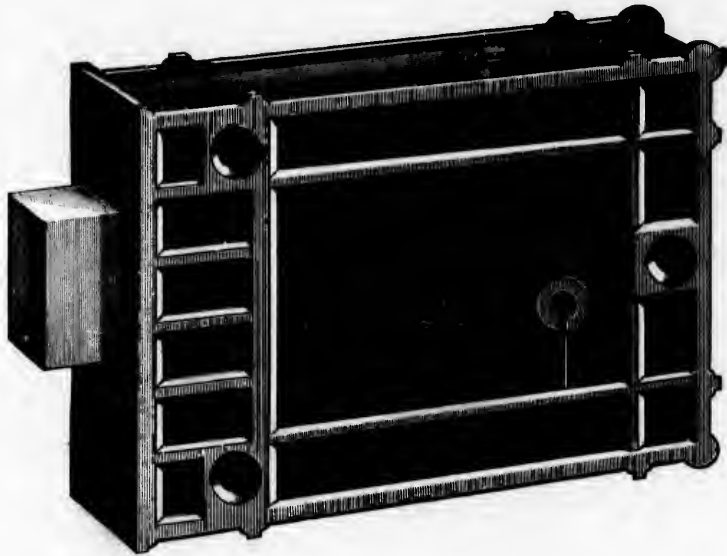

4 x 3 inch. Full size cut.

Peterboro'. Gurney.

No. 120	R2200 $\frac{1}{2}$	—3 $\frac{1}{2}$ x 2 $\frac{1}{2}$ inch, Iron Bolt, Tinned Malleable Key, 1 Tumbler.....	per doz.	\$2.00
" 121	R2200	—3 $\frac{1}{2}$ x 2 $\frac{1}{2}$ " " Nickered Steel Key, 1 "	"	2.90
" 130	R2220 $\frac{1}{2}$	—4 x 3 " " Tinned Malleable Key, 1 "	"	3.00
" 131	R2220	—4 x 3 " " Nickered Steel Key, 1 "	"	3.80
" 140	R2230 $\frac{1}{2}$	—5 x 3 $\frac{1}{2}$ " " Tinned Malleable Key, 1 "	"	4.00
" 141	R2230	—5 x 3 $\frac{1}{2}$ " " Nickered Steel Key, 1 "	"	4.80

Packed with Screws and Japanned Escutcheons.

Half-dozen in a box.

STORE DOOR DEAD LOCKS

UPRIGHT CYLINDER RIM, PIN TUMBLER

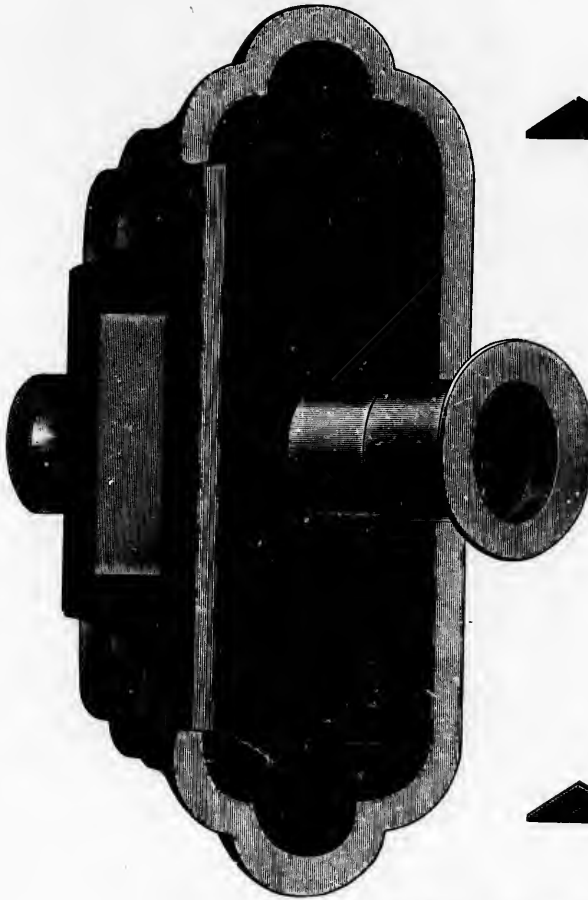

6 x 2½ inch. Full size cut.

HANDED, NOT REVERSIBLE

Operated from Outside by Key, Inside by Turn Knob.

FOR DOORS 1½ TO 2½ INCHES

Peterboro.							
No. 470	—Iron Bolt, Bronze Metal Turn Knob, 3 Nickered Steel Keys, Pin Tumblers, 100 Changes.. per doz.						\$30.00
" 471	—Bronze Bolt, " " " " " "	3	"	"	"	100	.. " 33.00

Packed one in a box, with Screws.

In ordering, state Hand wanted.

RIM STORE DOOR DEAD LOCKS

"HARVARD"

For Right or Left Hand Doors.

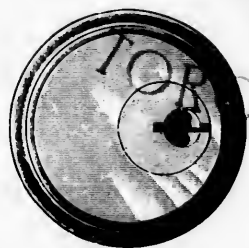
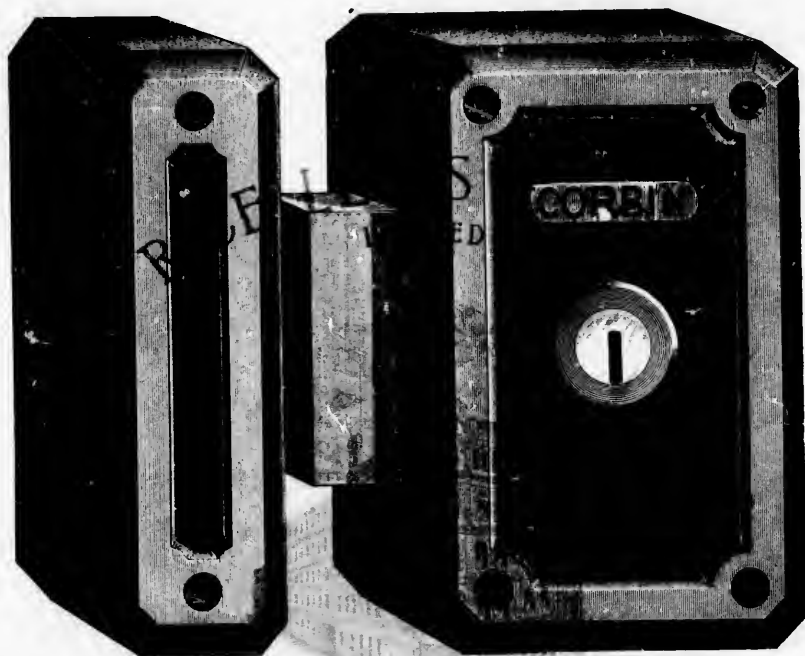

1 doz. \$30.00
38.00

Corbin's,
No. 1434—4 x 2 1/4 inch, Bronze Metal Bolt, Bronze Metal Cylinder, 3 Keysper doz. \$50.00

One in a box, with Screws.

MORTISE DEAD LOCKS

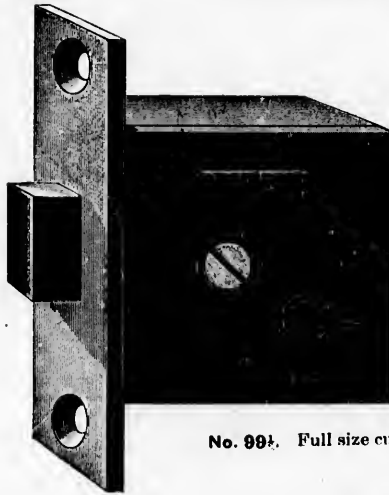

No. 99½. Full size cut.



Corbin's.

No. 99½—1½ x 2 inch, Brass Front and Strike, Iron Bolt, Nickel-Plated Steel Key...per doz. \$5.40

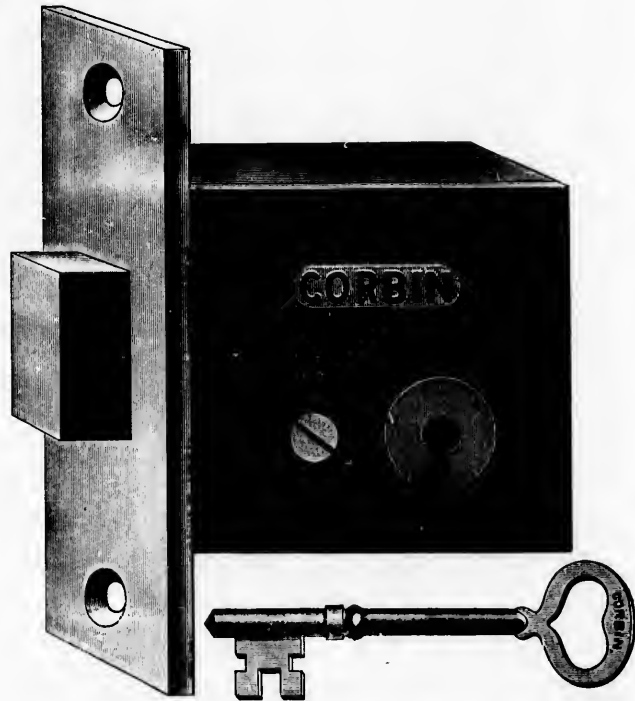

No 134B. Full size cut.

Corbin's.			
No. 134B	—2½ x 3½ inch, Bronze Metal Front, Strike and Bolt, 1 Tumbler, Nickel-Plated Steel Key, per doz.		9.80
" 145B	—3 x 3½ " " " " " " " " " " " "		20.00
Peterboro'. Gurney.			
No. 50—3½ x 2½, Iron Front and Bolt, Nickel-Plated Steel Key, 1 Tumbler	"	3.00
" 54—3½ x 2½, Brass Front, Bolt and Strike, Nickel-Plated Steel Key, 1 Tumbler.....	"	5.00
" 61	M51—2½ x 2½, Heavy, Brass Front, Strike and Bolt, 2 Nickel-Plated Steel Keys, 1 Tumbler	"	12.00

Half-dozen in a box.

Peterb
No. 18-
" 17-
" 18-
" 19-

MORTISE KNOB LATCHES

FOR FRENCH WINDOWS OR NARROW STILE DOORS



Nos. 16 and 17

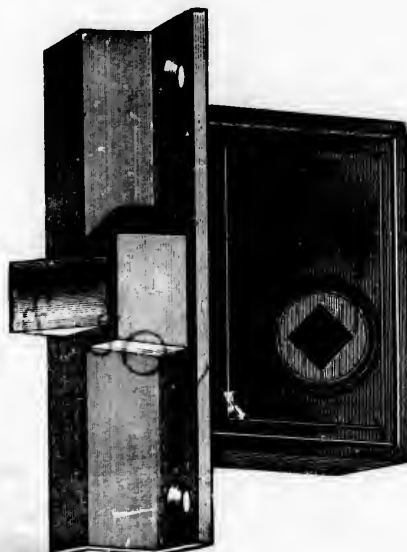

Nos. 18 and 19

RIGHT OR LEFT HAND, JAPANNED CASE

Peterboro'.			
No. 16	2½ x 1½ inch, Flat Iron Front and Strike, Brass Bolt and Hub	per doz.	\$ 8.00
" 17	2½ x 1½ " " Brass	"	9.00
" 18	2½ x 1½ " Rabbeted Iron Front and Strike, Brass Bolt and Hub	"	12.00
" 19	2½ x 1½ " " Brass	"	14.00

RIGHT OR LEFT HAND



3½ x 1½ inch, ROUND EDGE. Full size cut.

Peterboro'.		Gurney.	Per doz.
No. 0	M80	3½ x 1½, Flat Lacquered Iron Front and Strike, Iron Bolt	\$1.30
" 1	M90	3½ x 1½, Flat Lacquered Iron Front and Strike, Iron Bolt	2.10
" 4	M93	3½ x 1½, Flat Brass Front and Strike, Brass Bolt	3.50
" 6		3½ x 1½, Flat Lacquered Iron Front and Strike, Brass Bolt	3.00
" 12	M290	2½ x 1½, Rabbeted Lacquered Iron Front and Strike, Iron Bolt	4.00
" 13	M291	2½ x 1½, Rabbeted Lacquered Iron Front and Strike, Brass Bolt	5.00
" 14	M292	2½ x 1½, Rabbeted Brass Front and Strike, Brass Bolt	8.50

From No. 0 to 6, one dozen; 12 to 14, half-dozen in a box.

\$5.40

9.80
20.00
3.00
5.00
12.00

MORTISE LATCHES



No. 68 1/2 B



No. 2414 1/2

Hub for 3/8 inch Spindle.

No. 68 1/2 B—1 1/8 x 1 1/2 inch, Bronze Metal Front, Strike and Bolt, with No. 2414 1/2 Bronze Metal T Handle, Distance from Front to Centre of Hub 1 1/8 inch per doz. \$12.00

MORTISE NIGHT LATCH

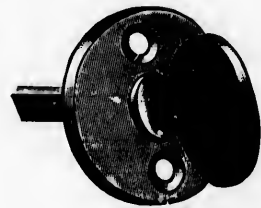
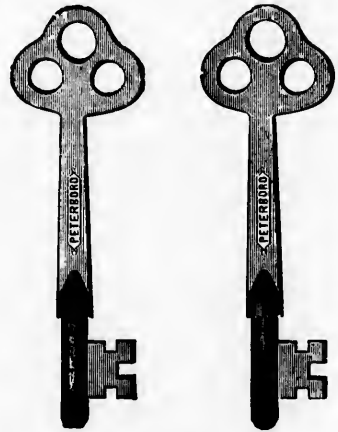
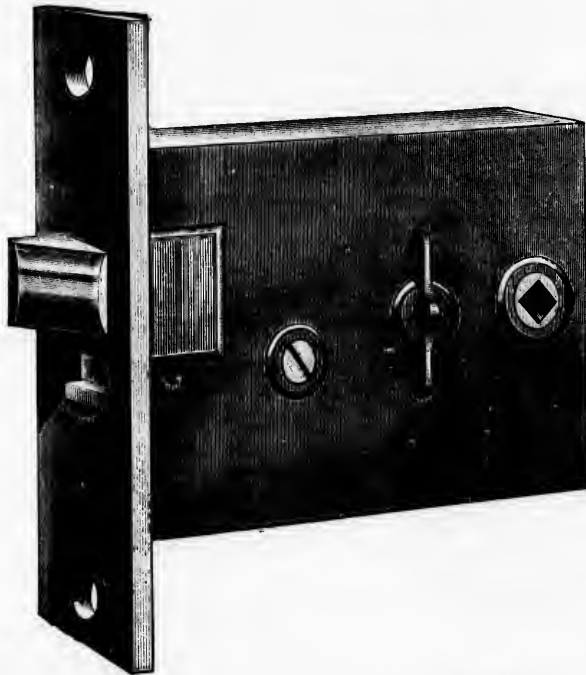

Full size cut.

Peterboro'.

No. 25-3 1/2 x 2 1/2 inch, Brass Front, Strike and Bolt, Bronze Thumb Knob, 2 Nicked Steel Keys, 1 Steel Tumbler per doz. 8.50

For Right or Left Hand Doors. Packed with Screws and Japanned Escutcheon.
Half-dozen in a box.

MORTISE NIGHT LATCHES

Full size cut.

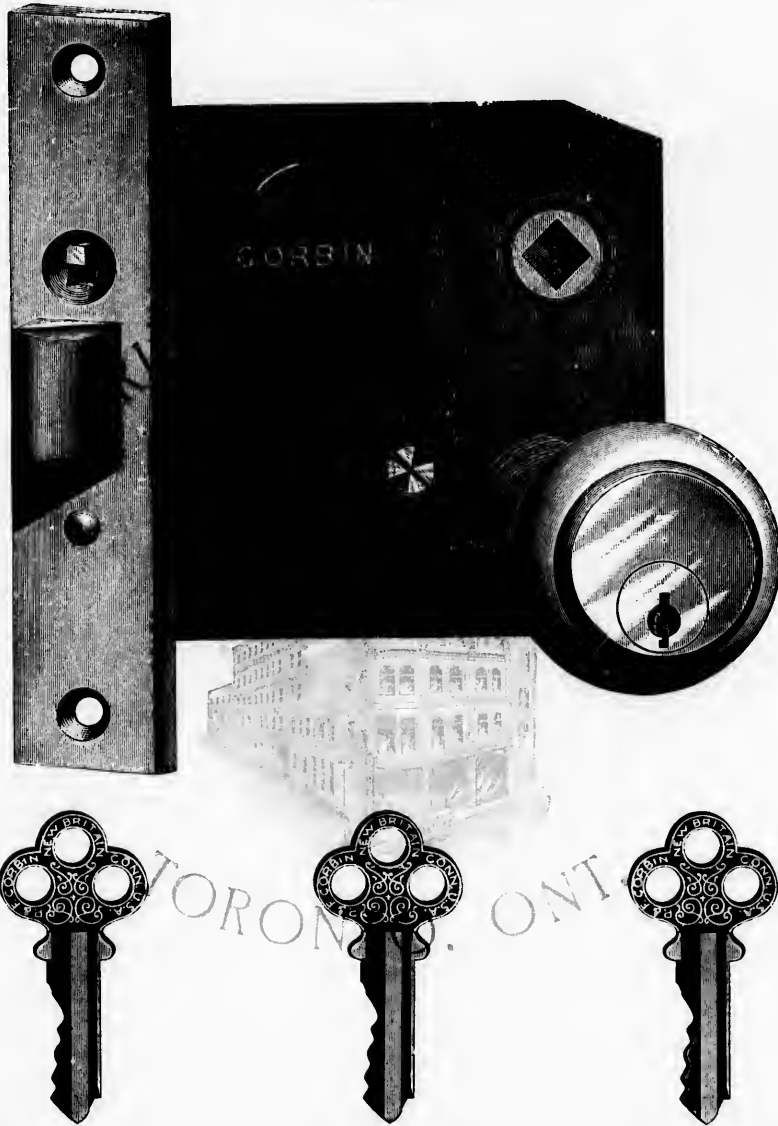

Adjustable to Right and Left Hand Doors $1\frac{1}{4}$ to 2 inch thick.

Corbin's
 No. 558B— $3\frac{1}{4}$ x 3 $\frac{1}{2}$ inch, Bronze Metal Front, Bolt, Strike and Cylinder, with Bronze Metal Knob, 3 Keyed,
 per doz

\$80.00

Steel,
 doz. \$12.00



Steel
 doz. 8.50

MORTISE KNOB LOCKS



3½ inch. Full size cut.

REVERSIBLE, FLAT FRONT

Peterboro'.	Gurney.		Per doz.
No. 206	M900	— 3½ x 3½ inch, Coppered Iron Front and Strike, Iron Bolts, Tinned Iron Key, 1 Tumbler..	\$2.50
" 210	M902	— 3½ x 3½ " " " " " Malleable Iron Key	
		1 Tumbler.....	3.20
" 216	— 3½ x 3½ inch, Brass Front, Strike and Bolts, Nickeled Steel Key, 1 Tumbler	5.00
" 217	M904	— 3½ x 3½ " " " " " Coppered Iron Front and Strike, Brass Bolts, Nickeled Steel Key, 1 Tumbler	4.50
" 219	M905	— 3½ x 3½ " " " " " Brass " " " " " 1 " "	5.50
" 227	M1200	— 4 x 3½ " " " " " Plain Brass " " " " " Strike and Bolts " " " " " 1 " "	7.50
" 251	M1303	— 5 x 3½ " " " " " Heavy Bronze Metal Front, " " " " " 1 " "	18.00

TORONTO, ONT.

P. F. CORBIN'S MORTISE KNOB LOCKS

No.	Corbin's.		Per doz.
No. 1285B	— 3½ x 3½ inch,	Wrought Bronze Metal Front, Strike and Bolts, Nickeled Steel Key, 1 Tumbler...	6.00
" 786B	— 3½ x 3½ " "	Bronze Metal Front, Strike and Bolts, Nickeled Steel Key, 1 Tumbler	9.75
" 1362B	— 3½ x 3½ " "	" " " " " Easy Spring, Nickeled Steel Key, 1 Tumbler	14.00
" 1363B	— 4½ x 3½ " "	" " " " " " " " " " " 1 " "	16.20
" 1366B	— 4½ x 3½ " "	" " " " " " " " " " " Extra Heavy, " " " " " 4 " "	27.50

KEEPERS ONLY

Keepers only for No. 210 Locks	0.30
Keepers " " 219 "	0.75

Lock Nos. 251 and 1366B, quarter dozen; others, half-dozen in a box.

MORTISE KNOB LOCKS



Full size cut.

REVERSIBLE FLAT FRONT

Peterboro.	Gurney.				
No. 2219	M915	—3½ x 3½ inch, Bronze Metal Front and Strike, Steel Key, (3 Finish).....	per doz.	\$8.00	
" 4219	M918	—3½ x 3½ " Bronze-Plated " " " (10 ").....	"	6.00	

Peterb
No. 25
" 26
" 28
" 28
" 27

Peterb
No. 226
" 426

RABBETED MORTISE KNOB LOCKS

HANDED, NOT REVERSIBLE



No. 265. Full size cut.

PLAIN FRONTS

Peterboro.		Per doz.
No. 259	4½ x 3½ inch, Lacquered Iron Front, Strike and Bolts, Tinned Malleable Iron Key, 1 Steel Tumbler	\$16.00
" 260	4½ x 3½ " " " " Brass " Nickeled Steel Key, 1 Steel Tumbler	17.00
" 261	4½ x 3½ " Bronze Metal Front, Strike and Bolts " " " "	24.00
" 265	4½ x 3½ " Lacquered Iron " " " Tinned Malleable Key, 1 Steel Tumbler	16.00
" 270	4½ x 3½ " Reversible, Bronze Metal Front, Strike and Bolts, Nickeled Steel Key	25.00

ORNAMENTAL FRONTS

Peterboro.		
No. 2265	4½ x 3½ inch, Bronze Metal Front, Strike and Bolts, Nickeled Steel Key, (3 Finish)	24.00
" 4265	4½ x 3½ " Plated " " " Brass Bolts " " (10 ")	20.00

FRONT DOOR MORTISE LOCKS

"HARVARD"

With Thumb Knob to Operate Bolt on Inside of Door.

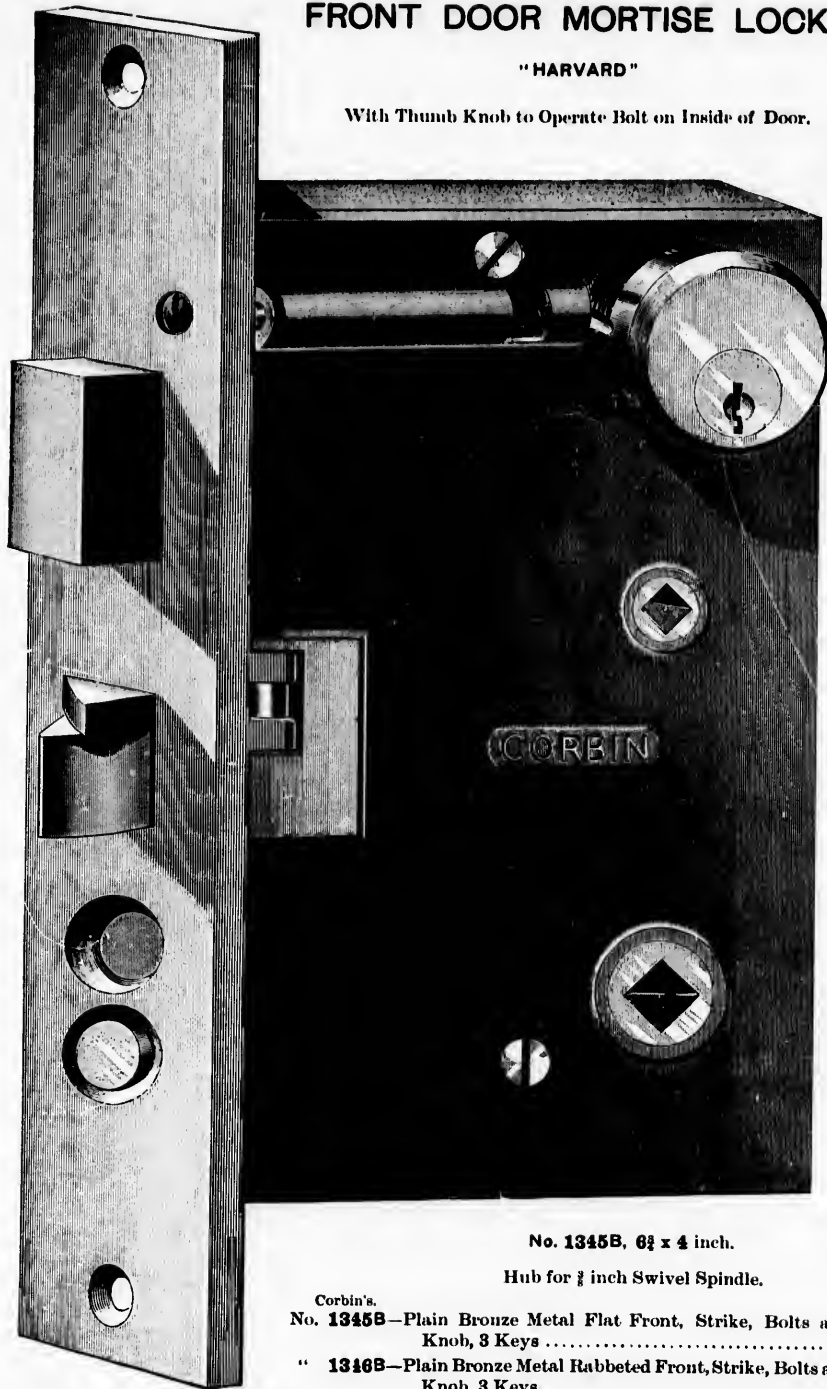

No. 1345B, 6 $\frac{1}{2}$ x 4 inch.

Hub for $\frac{3}{8}$ inch Swivel Spindle.

Corbin's.

No. 1345B—Plain Bronze Metal Flat Front, Strike, Bolts and Thumb Knob, 3 Keyseach \$ 8.10

" 1346B—Plain Bronze Metal Rabbeted Front, Strike, Bolts and Thumb Knob, 3 Keyseach 14.00

FRONT DOOR MORTISE KNOB LOCKS

WITH NIGHT WORKS

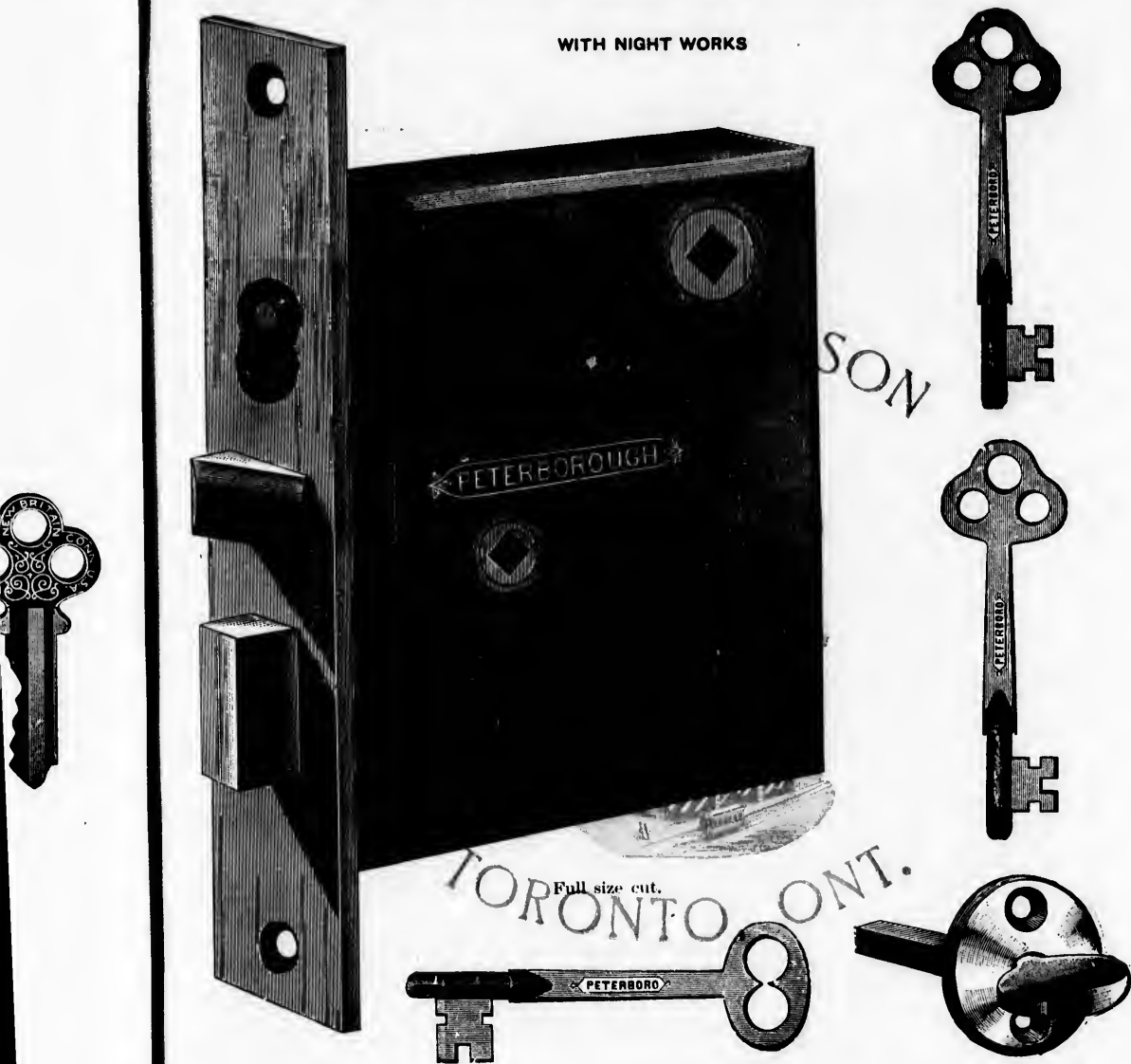

Reversible Latch Bolt, Steel Tumblers, Lever Action. Reverse by removing Cap.

Peterboro. Gurney.
 No. 550 M203—4½ x 3½ inch, Bronze Metal Bolts, Front, Strike and Thumb Knob, 2 Nickered Night
 Keys, 1 Nickered Key for Locking Bolt, 1 Steel Tumbler.....per doz. \$30.00

One-twelfth dozen in a box.

hb
 ch \$ 8.10
 hb
 ch 14.00

RABBETED FRONT DOOR MORTISE KNOB LOCKS

WITH NIGHT WORKS



Full size cut.

Handed, not Reversible, Steel Tumblers, Lever Action.

Peterboro' Gurney.
 No. 553 M353—4 $\frac{1}{2}$ x 3 $\frac{1}{2}$ inch, Bronze Metal Bolts, Front, Strike and Thumb Knob, 2 Nickered Night
 Keys, 1 Nickered Key for Locking Bolt, 1 Steel Tumbler per doz. \$40.00

One-twelfth dozen in a box.

KS

MORTISE INSIDE DOOR SETS

"WARNER" COLD ROLLED STEEL



OLD COPPER FINISH

No. 2002— $3\frac{1}{2}$ x $3\frac{1}{2}$ x $\frac{1}{2}$ inch, Brass Front, Strike and Bolts, Pressed Steel Knobs, 2 Elongated Escutcheons, 1 Steel Key..... per doz. sets \$14.00

PLAIN BRONZE-PLATED

No. 2005— $3\frac{1}{2}$ x $3\frac{1}{2}$ x $\frac{1}{2}$ inch, Brass Front, Strike and Bolts, Jet Knob, 2 Elongated Escutcheons, 1 Steel Key, per doz. sets..... 13.00



ght
loz. \$40.00

The above is a half size cut of the Lock for sets Nos. 2002 and 2005. The Case is made of Seamless High Grade Cold Rolled Steel. The Screw Holes, Pressed, Countersunk and absolutely uniform; Brass Hubs.

INSIDE DOOR SETS

P. & F. CORBIN'S

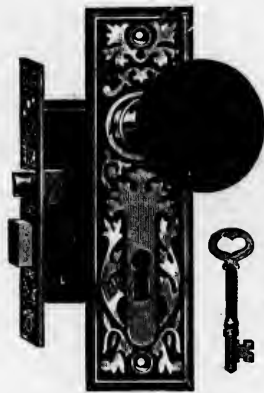

No. PS100, FIGURED

Bronzed Plated, Wrought Steel.

Lock $3\frac{1}{2} \times 3\frac{1}{2}$, Knobs $2\frac{1}{2}$, 2 Escutcheons $5\frac{1}{2}$ inch.

The Locks are Wrought Steel-Plated Front, Brass Bolts, 1 Tumbler, Knobs with Bronzed Shank, Rose and Escutcheons Wrought Steel, Bronzed.

No. **PS100**—Jet Knob per doz. sets \$9.00
 " **PS101**—Bronze-Plated Knob " " 11.50

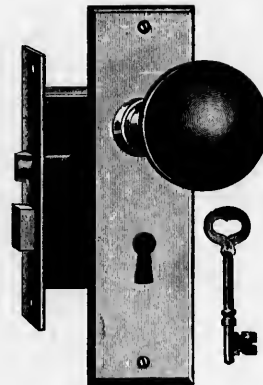

No. S150, PLAIN

Wrought Bronze Metal.

Lock $3\frac{1}{2} \times 3\frac{1}{2}$, Knobs $2\frac{1}{2}$, 2 Escutcheons $5\frac{1}{2}$ inch.

The Lock, Face and Bolts, Knobs and Escutcheons are made of Wrought Bronze Metal.

No. **S150** per doz. sets \$16.20

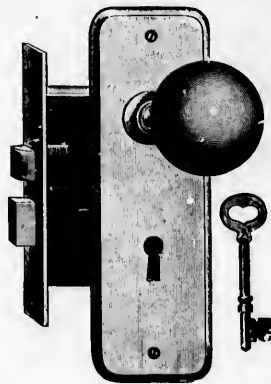

No. S200, PLAIN

Bronze Metal

Lock $3\frac{1}{2} \times 3\frac{1}{2}$, Knobs $2\frac{1}{2}$, 2 Escutcheons $5\frac{1}{2} \times 2$ inch.

The Locks are Easy Spring, with Heavy Bronze Metal Front, Strike and Bolts. The Knobs Solid, Bronze Metal, Escutcheons Wrought Bronze Metal.

No. **S200** per doz. sets \$27.00



No. F200, SAND BLAST, OXIDIZED COPPER

Bronze Metal.

Lock $3\frac{1}{2} \times 3\frac{1}{2}$, Knobs $2\frac{1}{2}$, 2 Escutcheons $7\frac{1}{2} \times 2$ inch.

The Locks are Easy Spring with Heavy Bronze Metal Front, Strike and Bolts. The Knobs Solid, Bronze Metal, Escutcheons Wrought Bronze Metal.

No. **F200** per doz. sets \$30.00

P. & F. CORBIN'S DOOR TRIMMINGS

DESIGN "LORAINÉ"

Bronze Metal, Sand Blast, Old Copper Finish.



SET No. S253

Reversible.

- No. 785B—Lock, 3 $\frac{3}{4}$ x 3 $\frac{1}{2}$ inch.
- " 5251—Knob, 2 $\frac{1}{2}$ inch.
- " 5252 $\frac{1}{2}$ —Rose and Escutcheon, 8 $\frac{1}{2}$ x 2 $\frac{1}{2}$ inch.



SET No. S255

Handed.

- No. 1345B—Cylinder Lock, 6 $\frac{3}{4}$ x 4 inch.
- " 5250 x 5251—Knobs, 2 $\frac{1}{2}$ x 2 $\frac{1}{2}$ inch.
- " 5252—Rose and Escutcheon, 10 x 3 inch.
- " 5252 $\frac{1}{2}$ — " " 8 $\frac{1}{2}$ x 2 $\frac{1}{2}$ "



SET No. S 250

Reversible.

- No. 1092B—Lock, 5 $\frac{1}{2}$ x 3 $\frac{3}{4}$ inch.
- " 5255—Escutcheon.

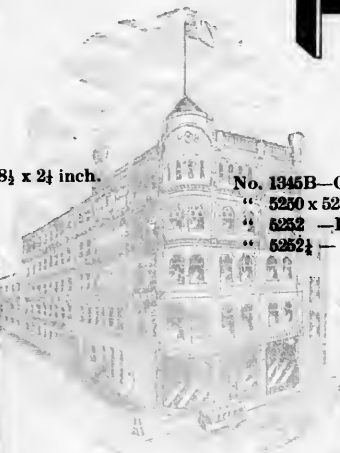

TORONTO, ONT.



No. 5254



No. 5257

No. S253—Inside Door Set	per set	\$2.65
" S254—Front " (Design as S255, no Cylinder, but with Night Works, 3 Keyed)	"	4.00
" S255—" " with 3 Paracentric German Silver Keys	"	12.20
" S250—Sliding Door Set, Flat Front, for Single Doors	"	2.80
" S251—" " " " Double "	"	4.40
" S252—" " " Astragal Front for Double Doors	"	5.40
" 5254—Electric Push Buttons	per doz.	11.50
" 5257—Flush Sash Lifts	"	2.50

Lock Sets, one in a box.

FRONT DOOR SETS

P. & F. CORBIN'S

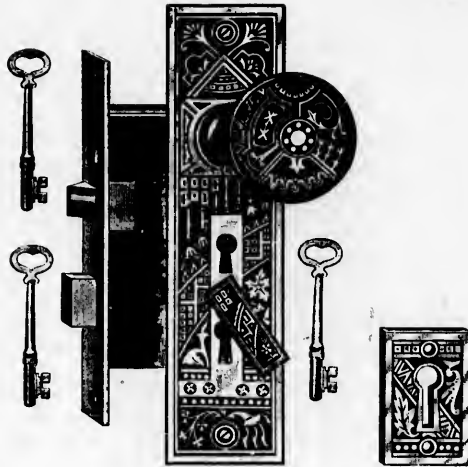

Set No. S751

WROUGHT BRONZE METAL

Reversible, Swivel Spindle.

- No. 1230B—Lock, $4\frac{1}{2} \times 3\frac{3}{4}$ inch.
- " 4583 —Knob, $2\frac{1}{2}$ inch.
- " 4965 $\frac{1}{2}$ —Rose and Escutcheon, $7\frac{1}{4} \times 1\frac{1}{2}$ inch.
- " 2104 $\frac{1}{2}$ —Small Escutcheon.



Set No. S750

BRONZE METAL

Reversible, Swivel Spindle.

- No. 1230B—Lock, $4\frac{1}{2} \times 3\frac{3}{4}$ inch.
- " 1583 —Knob, $2\frac{1}{2}$ inch.
- " 2589 —Rose and Escutcheon, $7\frac{1}{4} \times 2$ inch.
- " 2506 $\frac{1}{2}$ —Small Escutcheon.

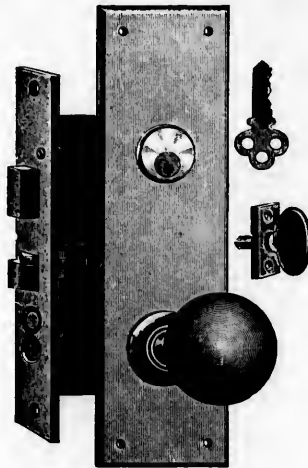

Set No. S875

BRONZE METAL

Handed, Swivel Spindle.

- No. 1345B—Cylinder Lock, $6\frac{1}{2} \times 4$ inch.
- " 1518 $\frac{1}{2}$ —Knob, $2\frac{1}{2}$ inch.
- " 2582 $\frac{1}{2}$ —Rose and Escutcheon, $10 \times 2\frac{1}{2}$ in. h.
- Same Key operates both Latch and Lock.
- No. S751—Front Door Set..... per set \$2.00
- " S875— " " " " " " " " " " " 11.50

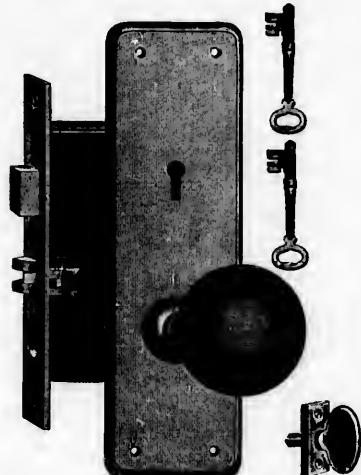

Set No. S850

BRONZE METAL

Reversible, Swivel Spindle.

- No. 1350 $\frac{1}{2}$ B—Lock, $6 \times 3\frac{3}{4}$ inch.
- " 1511 — Knob, $2\frac{1}{2}$ inch.
- " 02588 $\frac{1}{2}$ —Rose and Escutcheon, $8 \times 2\frac{1}{2}$ inch.
- Same Key operates both Latch and Lock.
- No. S750—Front Door Set..... per set \$2.50
- " S850— " " " " " " " " " " " 7.50

One in a box.

FRONT DOOR SET

P. & F. CORBIN'S

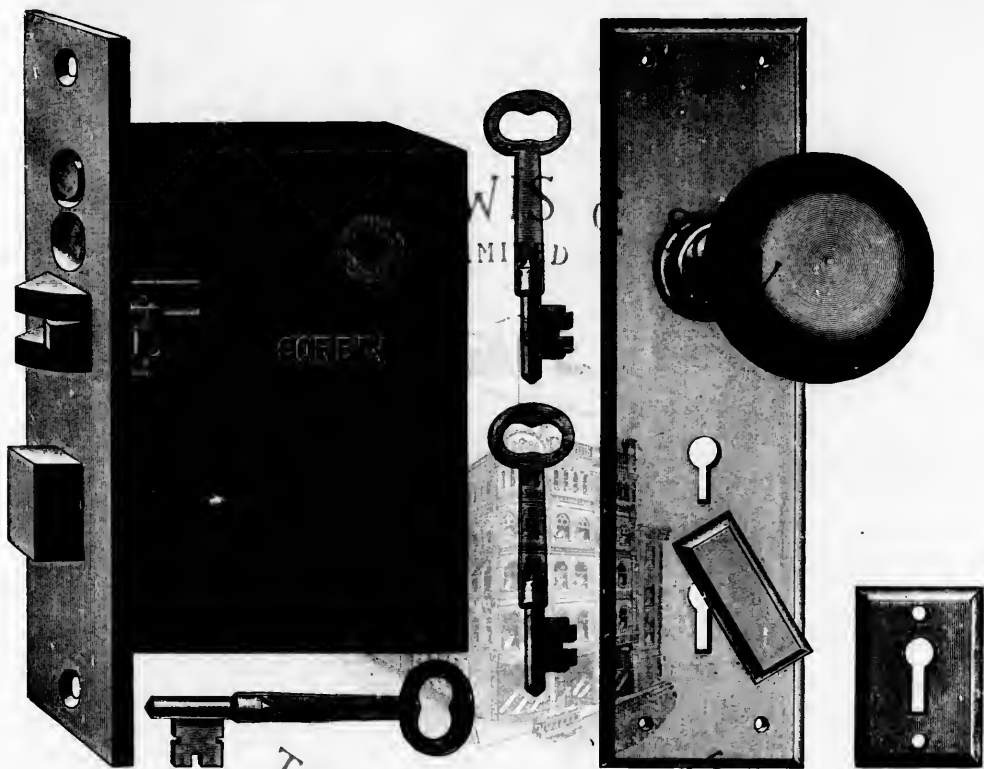

TORONTO, ONT. 7 1/2 inch.

SET No. S800

Reversible, Swivel Spindle.

Set comprises:—No. 1290B, Lock $4\frac{1}{4}$ x $3\frac{3}{8}$ inch; Anti-Friction Latch; one pair No. 1518 $\frac{1}{2}$ x 1519 $\frac{1}{2}$ Knobs, $2\frac{1}{4}$ x $2\frac{1}{4}$ inch; one No. 2580 Rose and Escutcheon, $7\frac{1}{2}$ x 2 inch; one No. 2600 $\frac{1}{2}$ Small Escutcheon.

No. S800 - Front Door Set per set \$5.40

One set in a box.

ch.
set \$2.50
7.50

FRONT DOOR MORTISE SETS

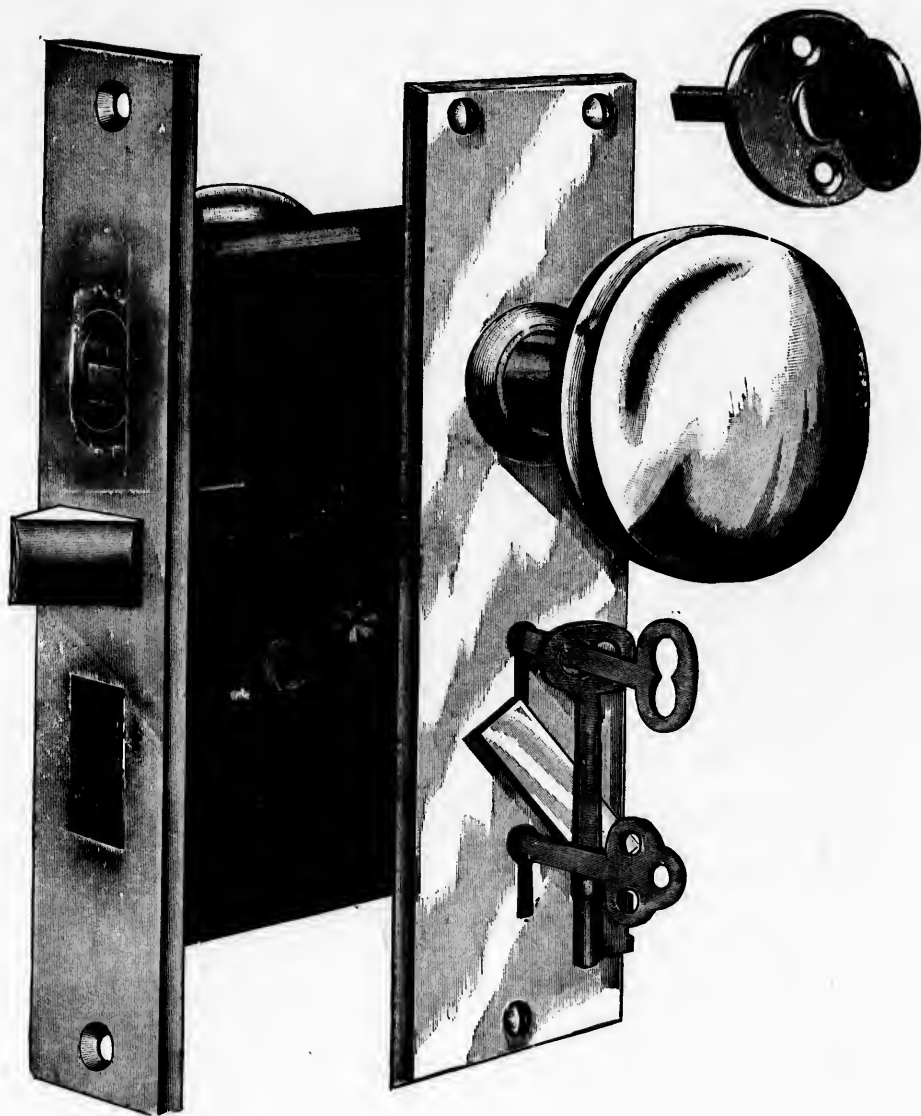

REVERSIBLE

Peterboro.
No. 0549

Gurney.

M0200— $4\frac{3}{4}$ x $3\frac{3}{4}$ inch, Plain Bronze Metal..... per set \$3.00

One set in a box.

FRONT DOOR MORTISE SETS



REVERSIBLE

Peterboro. Guruey.
 No. **02549** **M0212**—4½ x 3¾ inch, Ornamental Bronze Metal..... per set \$3.00

Will be sent in 3 Finish, unless otherwise ordered.

One set in a box.

set \$3.00

SLIDING DOOR LATCHES

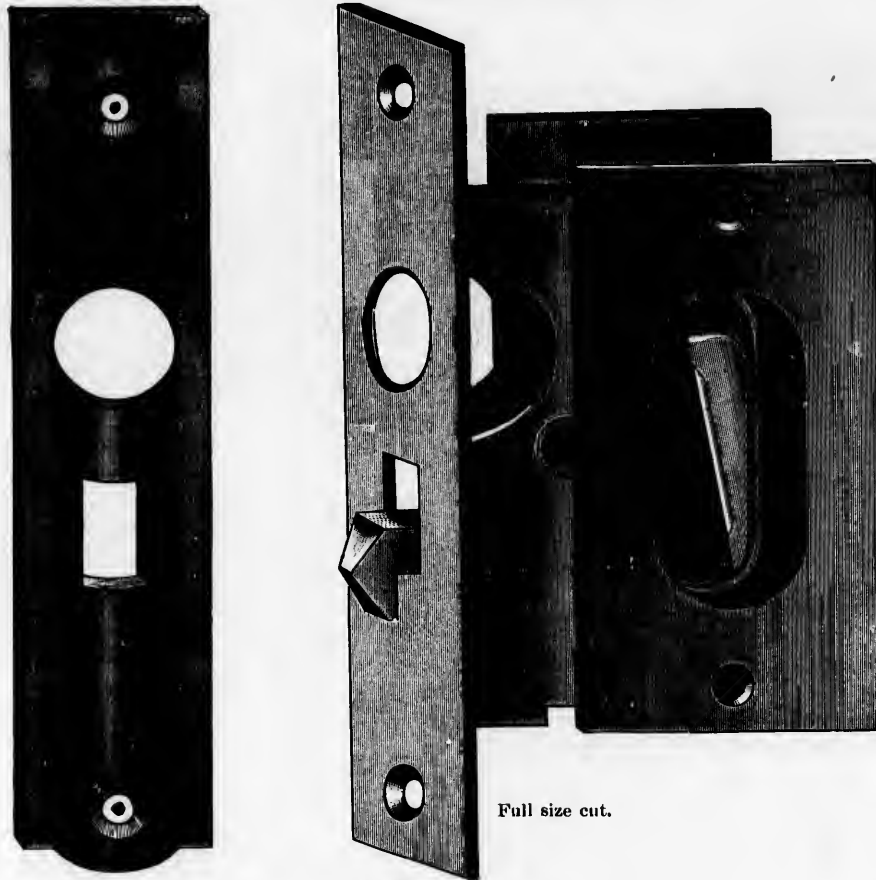

ASTRAGAL FRONT

FLAT FRONT

Full size cut.

Peterboro.	Curney.		Per set.
No. 37	M461	$\frac{1}{2}$ — $3\frac{1}{4}$ × $3\frac{1}{4}$ inch, Bronze Metal Flat Front, Strike and Bolt, 2 Flush Escutcheons, for Single Doors.....	\$1.75
" 40	M461	$\frac{1}{2}$ — $3\frac{1}{4}$ × $2\frac{1}{4}$ inch, Bronze Metal Flat Front, Strike and Bolt, 4 Flush Escutcheons, for Double Doors.....	2.17
" 43	M461	$\frac{1}{2}$ — $3\frac{1}{4}$ × $3\frac{1}{4}$ inch, Bronze Metal Astragal Front, Strike and Bolt, 2 Flush Escutcheons, for Single Doors.....	2.00
" 46	M461	$\frac{1}{2}$ — $3\frac{1}{4}$ × $3\frac{1}{4}$ inch, Bronze Metal Astragal Front, Strike and Bolt, 4 Flush Escutcheons, for Double Doors.....	2.50

P. & F. CORBIN'S SLIDING DOOR LATCHES

Corbin's.			
No. N10391	$\frac{1}{2}$ — $3\frac{1}{4}$ × $3\frac{1}{4}$ inch, Bronze-Plated Flat Front and Strike, Bronze Metal Bolts, 2 Bronze-Plated Flush Escutcheons, for Single Doors.....		1.30
" N10391	$\frac{1}{2}$ — $3\frac{1}{4}$ × $3\frac{1}{4}$ inch, Bronze-Plated Flat Front and Strike, Bronze Metal Bolt, 4 Bronzed Flush Escutcheons, for Double Doors.....		1.50
" N10392	$\frac{1}{2}$ — $3\frac{1}{4}$ × $3\frac{1}{4}$ inch, Bronze-Plated Astragal Front and Strike, Bronze Metal Bolt, 4 Flush Escutcheons, for Double Doors.....		1.70

One set in a box.

SLIDING DOOR LATCHES

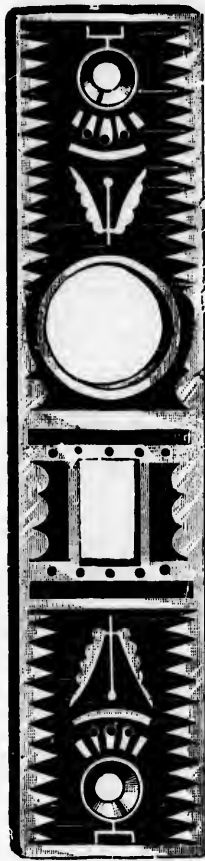

FLAT FRONT



ASTRAGAL FRONT



Full size cut.

PRICE LIST

TORONTO, ONT.

Peterboro'.	Gurney.	Per set.
No. 2037	M466 —3½ x 3¼ inch, Bronze Metal Flat Front, Strike and Bolt, 2 Flush Escutcheons, for Single Doors.....	\$1.75
" 2040	M470 —3½ x 3¼ inch, Bronze Metal Flat Front, Strike and Bolt, 4 Flush Escutcheons, for Double Doors.....	2.17
" 2043	M466 —3½ x 3¼ inch, Bronze Metal Astragal Front, Strike and Bolt, 2 Flush Escutcheons, for Single Doors.....	2.00
" 2046	M470 —3½ x 3¼ inch, Bronze Metal Astragal Front, Strike and Bolt, 4 Flush Escutcheons, for Double Doors.....	2.50

Will send 3 Finish, unless otherwise ordered.

P. & F. CORBIN'S SLIDING DOOR LATCHES

Corbin's		Per set.
No. P0391 ½	—3½ x 3¼ inch, Persian Bronze-Plated Flat Front and Strike, Bronze Metal Bolt, 2 Bronze-Plated Escutcheons, for Single Doors.....	1.30
" P0391	—3½ x 3¼ inch, Persian Bronze-Plated Flat Front and Strike, Bronze Metal Bolt, 4 Bronze-Plated Escutcheons, for Double Doors.....	1.50
" P0391	—3½ x 3¼ inch, Persian Bronze-Plated Astragal Front and Strike, Bronze Metal Bolt, 4 Bronze-Plated Escutcheons, for Double Doors.....	1.70

One set in a box.

FLUSH SLIDING DOOR MORTISE LOCKS

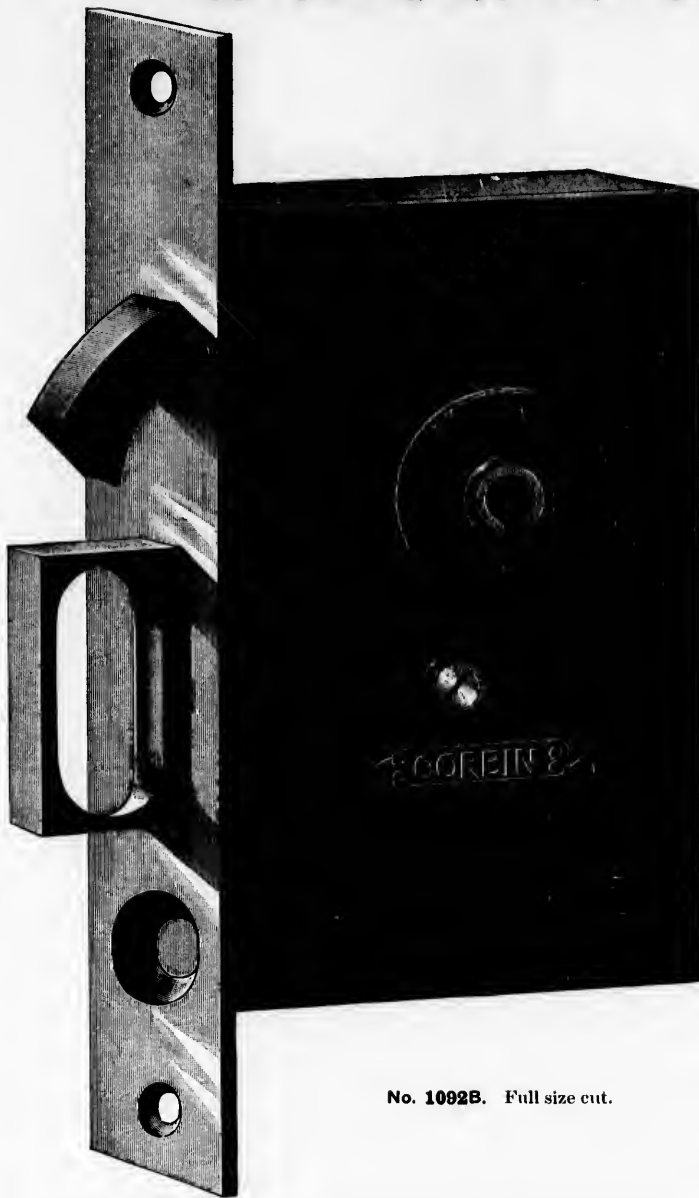

No. 1092B. Full size cut.

Corbin's.		Per set.
No. 1092B	—5½ x 3½ inch, Bronze Metal Flat Front and Strike, Bronze Metal Bolts, 2 Bronze Metal Cup Escutcheons 4½ x 2½ inch, Extension Key, for Single Doors.....	\$2.00
" 1100B	—5½ x 3½ inch, Bronze Metal Front and Strike, Bronze Metal Bolts, 4 Bronze Metal Cup Escutcheons 4½ x 2½ inch, Extension Key, for Double Doors.....	2.80
" 1108B	—5½ x 3½ inch, Bronze Metal Astragal Front, Strike and Bolt, 4 Bronze Metal Cup Escutcheons 4½ x 2½ inch, Extension Key, for Double Doors.....	3.60

Nos. 1100B and 1108B, 2 Locks in a set; No. 1092B, 1 Lock and Strike.

One set in a box.

No. 30
" 30

No. 33

No. 3

" 3

No. 3

" 3

1
3 inc
state

**DOOR KNOBS
JAPANNED MOUNTINGS**



No. 307—Rim, 2½ inch.....per doz.	\$1.65	No. 306—Mortise, 2½ inch.....per doz.	\$1.65
" 307½— " (Seconds).....	1.30	" 306½— " (Seconds).....	1.30

PORCELAIN

JET

No. 337—Rim, 2½ inch.....per doz.	1.65	No. 336—Mortise, 2½ inch.....per doz.	1.65
-----------------------------------	------	---------------------------------------	------

PLATED MOUNTINGS



PORCELAIN

No. 319—Rim, 2½ inch, Plated on Iron Necks and Brass Roses.....per doz.	\$3.45	No. 318—Mortise, 2½ inch, Plated on Iron Necks and Brass Roses.....per doz.	3.45
" 321—Rim, 2½ inch, Plated on Brass Necks and Roses.....per doz.	4.80	" 320—Mortise, 2½ inch, Plated on Brass Necks and Roses.....per doz.	4.80

JET

No. 339—Rim, 2½ inch, Plated on Iron Necks and Brass Roses.....per doz.	3.45	No. 338—Mortise, 2½ inch, Plated on Iron Necks and Brass Roses.....per doz.	3.45
" 341—Rim, 2½ inch, Plated on Brass Necks and Roses.....per doz.	4.80	" 340—Mortise, 2½ inch, Plated on Brass Necks and Roses.....per doz.	4.80

Rim Knob Locks extend on their Spindles ¾ inch, as follows: 1½ to 2½ inches, 1¾ to 2¾ inches, 2 to 2¾ inches, 2½ to 3 inches. Mortise Knobs extend on their Spindles 1 inch, as follows: 1 to 2 inches, 1½ to 2½ inches. In ordering, state length of Spindles required, and if for Rim or Mortise Locks.

Half-dozen in a box.

Per set.
\$2.00
2.80
3.00

DOOR KNOBS

2 1/2 INCH

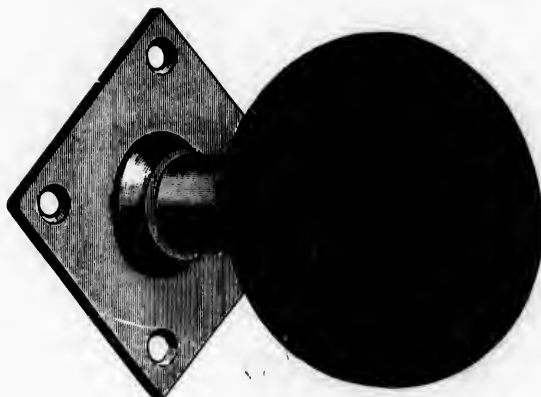

No. 502

JET

Peterboro's	Gurney.	Per doz.
No. 502Mortise, Bronze Metal Neck and Rose.....	\$5.00
" 503Rim, Bronze Metal Neck and Rose.....	5.00

Furnished with Round Rose if desired.

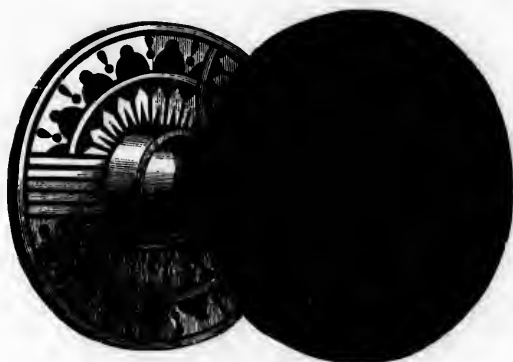

No. 4504

JET

Peterboro's	Gurney.	
No. 4504	815—Mortise, Bronze-Plated Neck, Ornamental Rose	3.45
" 4505	815—Rim, Bronze-Plated Neck, Ornamental Rose	3.45



No. 4500

ORNAMENTAL

Peterboro's	Gurney.	
No. 2500	314—Bronze Metal (3 finish)..	12.00
" 3500	318—Berlin Bronzed	4.00
" 4500	316—Bronze-Plated (10 finish)	6.00
" 5500	319—Nickel-Plated	6.00

In ordering state length of Spindles required and if for Rim or Mortise Locks.

Half-dozen in a box.

DOOR KNOBS

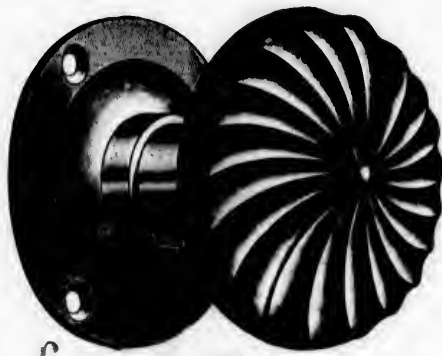
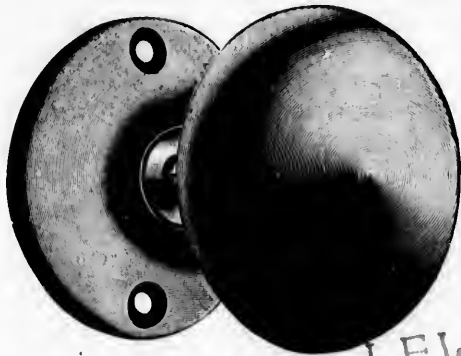

No. 1500P

No. 1506

No. 4900P—2½ inch, Bronzes Plated per doz. \$ 7.00
 " 1519—2½ " Plain Bronze Metal .. 14.00
 " 1518—2½ " " " " " " 10.50
 " 1518—3 " " " " " " 40.00

No. 1506—2½ inch, Plain Bronze, Fluted per doz. \$20.50
 No. 1505—2½ " " " " " " 31.50

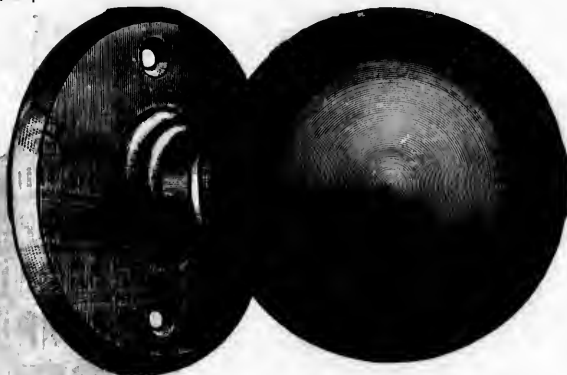
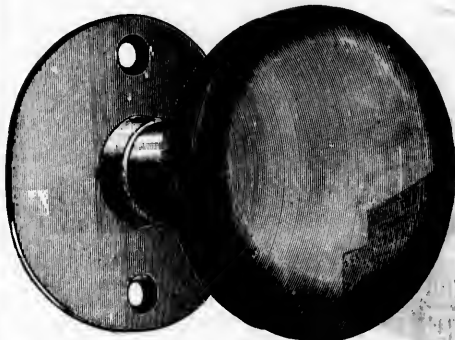

No. 2535

No. 2545

No. 2535—2½ inch, Plain Bronze per doz. \$10.00 | No. 2545—2½ inch, Plain Bronze per doz. \$22.00

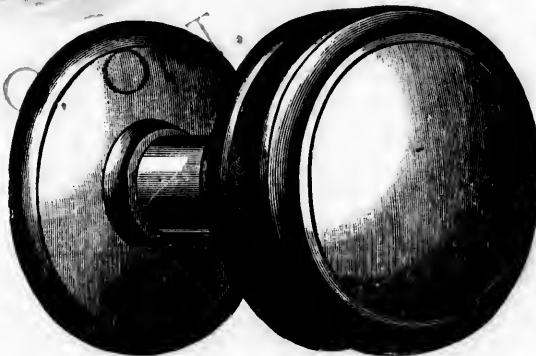

No. 2533

No. 2520

No. 2533—2½ inch, Plain Bronze per doz. \$11.00 | No. 2520—2½ inch, Plain Bronze per doz. \$16.00
 Half-dozen in a box.

Per doz.
 Metal
 \$5.00
 Neck
 5.00
 Painted.

Plated
 Rose 3.45
 Painted
 Rose 3.45

..... 12.00
 4.00
 (fish) 6.00
 6.00
 No. required

DOOR KNOBS

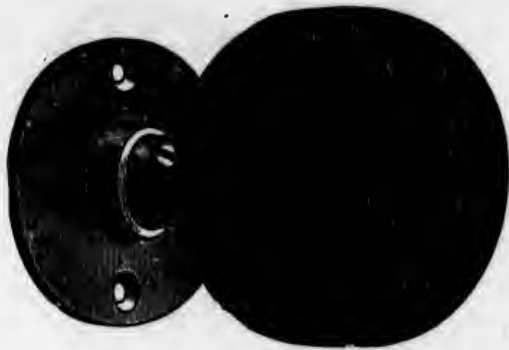

MORTISE WOOD DOOR (KNOBS

2½ inch.

No. 212—Assorted Woods, with Plain, Cast Bronze Metal Roses and Shanks.....per doz. \$8.00

" 240—Assorted Woods, with Wood Roses.....per doz. 4.00

CUPBOARD KNOBS

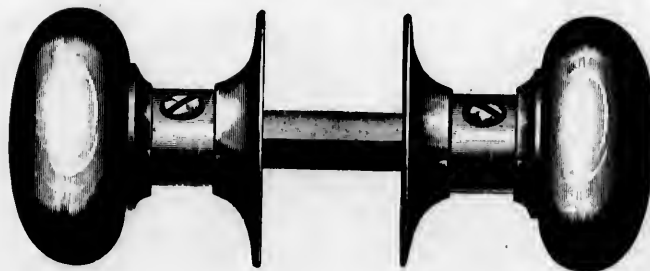

No. 1919—1½ inch, Bronze Metal, ½ Spindle.....per doz. 15.00

FRENCH WINDOW MORTISE CRANK HANDLE KNOBS

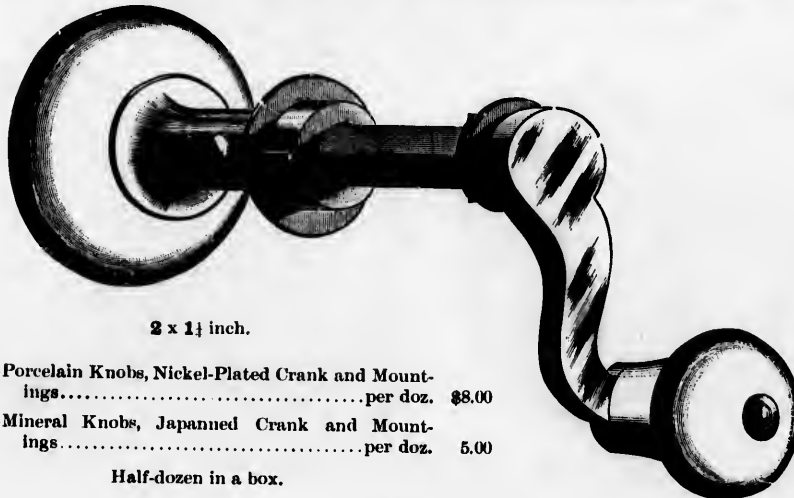

2 x 1½ inch.

No. 381 —Porcelain Knobs, Nickel-Plated Crank and Mountings.....per doz. \$8.00

" 328½—Mineral Knobs, Japanned Crank and Mountings.....per doz. 5.00

Half-dozen in a box.

No. 9-1
" 9-2

Plain Sp
Swivel
Swivel

No. 1
No. 182
" 483
" 259
" 269

No. 782
" 479
" 258
" 358
" 458
" 278
" 358
" 458

SIDE KNOB SCREWS



Full size cut.

No. 9—Iron Blued, length $\frac{3}{4}$ inch.....	per gross	\$0.40
" 9—Bronze Metal, " ".....	"	1.20

One gross in a package

KNOB SPINDLES



Plain Spindles, $\frac{1}{2}$ inch, for Rim or Mortise Knobs.....	per doz.	0.45
Swivel " " " Mortise Locks.....	"	2.20
Swivel " " " ".....	"	2.20

RICKLEWIS & SON
LIMITED
PLATE ESCUTCHEONS

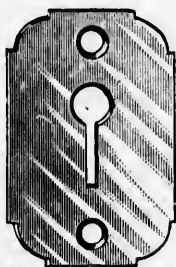

No. 182, FOR STEEL KEYS



No. 483



No. 2596

No. 182—Nickel-Plated.....	per doz.	0.30
" 483—Bronze Metal.....	"	0.40
" 2596 $\frac{1}{2}$ — " $1\frac{1}{4}$ x $1\frac{1}{4}$ inch.....	"	0.55
" 2694 $\frac{1}{2}$ — " $1\frac{1}{4}$ x $\frac{3}{4}$ ".....	"	0.50



No. 782

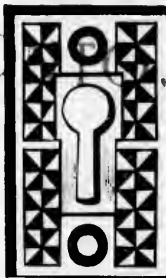

No. 2583



No. 2782

No. 782—Plain Bronze Metal.....	per doz.	1.20
" 4792—Plain Bronze-Plated (Pattern as 782).....	"	0.80
" 2583—Bronze Metal (3 finish).....	"	0.70
" 3583—Amber Bronzed (Pattern as 2583).....	"	0.40
" 4583—Bronze-Plated (10 finish) (Pattern as 2583).....	"	0.50
" 2782—Bronze Metal (3 ").....	"	1.70
" 3582—Amber Bronzed (Pattern as 2782).....	"	0.50
" 4582—Bronze-Plated (10 finish), (Pattern as 2782).....	"	0.80

ROSE AND ESCUTCHEONS

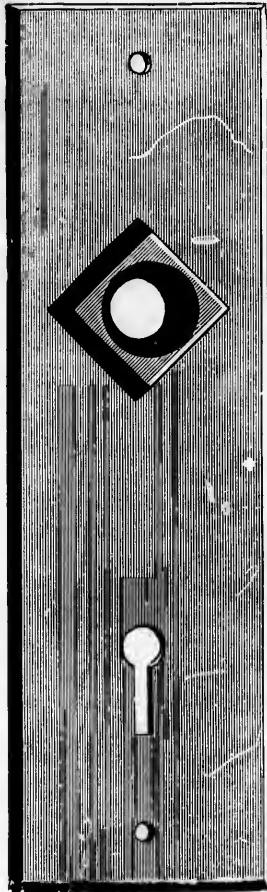

No. 578. Full size cut.

BRONZE METAL

	Per doz.
No. 579—For 3½ inch Mortise Locks..	\$3.50
“ 578—For 4 inch Mortise Locks..	4.00
“ 577—For 4½ inch Mortise Locks..	4.00
“ 576—For 5 inch Mortise Locks..	7.00
And 5 inch Rim Locks, with Night Works.	

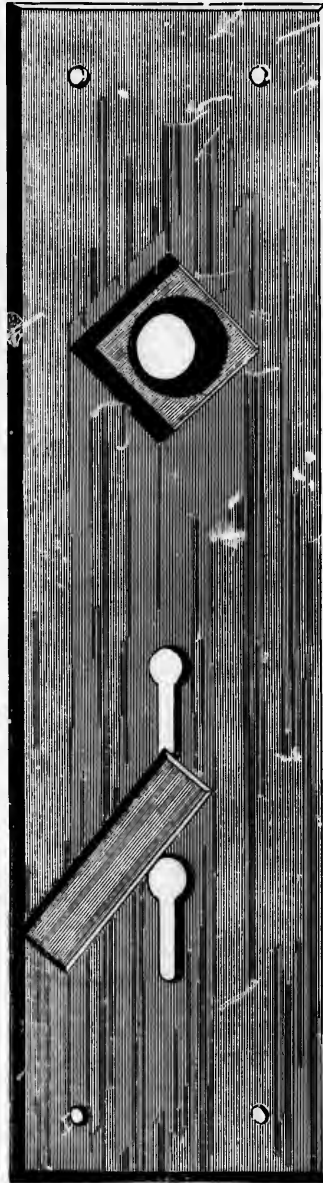

No. 575. Full size cut.

No. 575—Bronze Metal, for Mortise Front Door Locks, 4½ and 5 inch, and Rim Locks, with Night Works.....	Per doz. \$7.00
---	--------------------



No. 2579. Full size cut.

	Per doz.
No. 2576—For 3½ inch Mortise Locks.....	\$3.50
“ 2578—For 4 inch Mortise Locks.....	4.50
“ 2577—For 4½ inch Mortise Locks.....	4.50
“ 2576—For 5 inch Mortise Locks.....	6.00
And 5 inch Rim Locks, with Night Works.	
AMBER BRONZED	
“ 3579—For 3½ inch Mortise Locks.....	2.00
“ 3578—For 4 inch Mortise Locks.....	2.50
“ 3577—For 4½ inch Mortise Locks.....	2.50
BRONZE-PLATED (10 Finish)	
“ 4579—For 3½ inch Mortise Locks.....	2.50
“ 4578—For 4 inch Mortise Locks.....	3.00
“ 4577—For 4½ inch Mortise Locks.....	3.00

LATCH AND LOCK KEY BLANKS



Nos. 2, 3 and 4



6



8



98



99

No. 2	Blanks for Flat Key Outboard Locks	per doz.	\$0.00
No. 3	" " " Rim Night Latches	"	0.00
No. 4	" " " Store Door and Chest Locks	"	0.00
No. 6	" " " Corrugated "Yale" Rim Latches and Locks	"	2.00
No. 8	" " " Paracentric " " "	"	3.30
No. 98	" " " Harvard Locks, with 1 inch Cylinder	"	2.00
No. 98½	" " " " 1½ " " "	"	2.00
No. 98¾	" " " " 1½ " " "	"	2.70
No. 99	" " " new style	"	2.70



No. 100



No. 90

No. 100	Blanks for Rim Night Latches	Peterboro', Nos. 100 and 101	per doz.	\$1.25
No. 90	" " " " " "	" 90, " 91	30, 31, 32 and 33	1.00



No. 471



No. 170

No. 471	Blanks for Mortise Store Door Locks, Peterboro', Nos. 852 to 853A	per doz.	1.80
No. 170	" " " " " " Gurney " 603 " 627	"	1.80



No. 8416½

No. 8416½	Flat Steel Door Key Blanks	per gross	6.00
-----------	----------------------------	-----------	------

MORTISE LOCK KEYS AND BLANKS

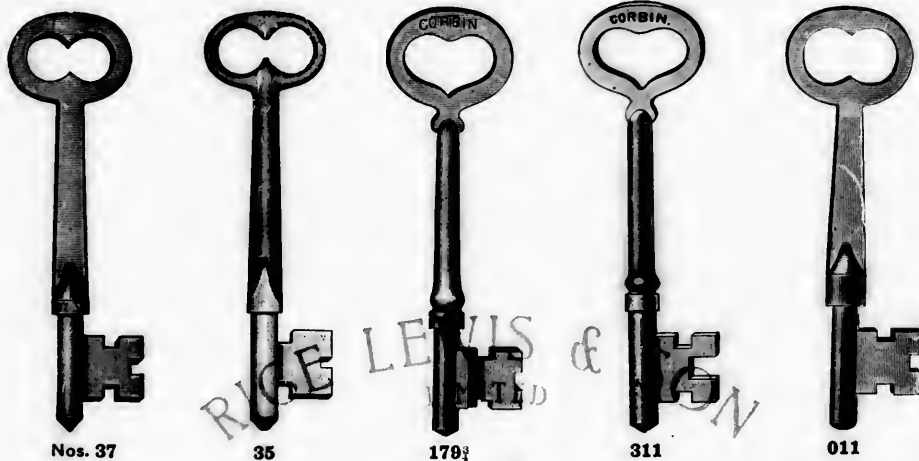

No.	Description	Peterboro' Nos.	Gurney.	Per doz.
No. 37	—Steel, Nickel-Plated, for Locks	Nos. 219	1300 to 1312	\$1.30
" 37	— " " Key Blanks	" 265	900 and 1000	1.30
" 35	—Tinned Malleable Iron, for Locks			0.50
" 179	—Steel, Nickel-Plated, for Corbin's No. 785B Locks			2.00
" 311	— " " " " " 1362			2.00
" 311	— " " " " " Key Blanks			2.00
" 011	—Tinned Malleable Iron, for Corbin's Common Mortise Locks			0.30

Three dozen in a box.

CABINET KEY BLANKS



Nos.	4616	4613	4602	4603	4218	4394	4425	
Nos.....	4616	4613	4602	4603	4604	4218	4394	4425
Per gross.....	\$10.00	8.00	3.00	2.50	3.30	16.80	5.50	8.40

ey. Per doz.
401 \$3.50

oz. 3.25
3.25



012
Per doz.
\$1.20
1.30
1.70
1.70
1.30
0.50
2.25
2.25
0.30

FLAT STEEL KEY BLANKS



Nos. 5543



5542



5541



: 5540



5549



5549 1/2

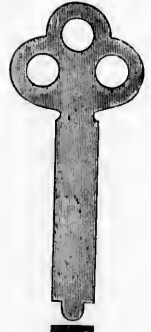

5549 1/4

Nos. 5540 to 5549 1/4—Flat Steel Key Blanks.....per gross \$3.00



Nos. 4132



4136



4126



4142

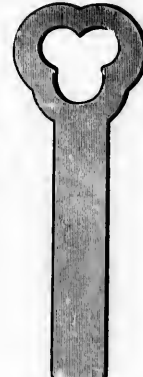

8493

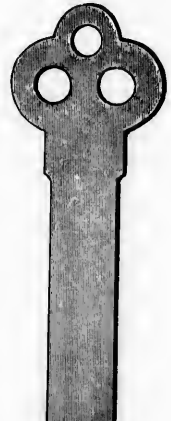

8531

Nos.....	4132	4136	4126	4142	8493	8531
Per gross.....	\$6.00	6.00	6.00	6.00	6.00	6.00

TRUNK KEY BLANKS



Nos. 5000 5001 5002 5005 5010 5011 5012

Nos. 5000 to 5012—Trunk Key Blanks.....per gross \$3.00



Nos. 5025 5028 5105 5106 5182 5190

Nos. 5025 and 5028—Trunk Key Blanks.....	per gross	3.00
“ 5105 — “ “ “ Drilled.....		10.00
“ 5106 — “ “ “		4.00
“ 5182 and 5190— “ “		4.00

PADLOCK AND BAG KEY BLANKS

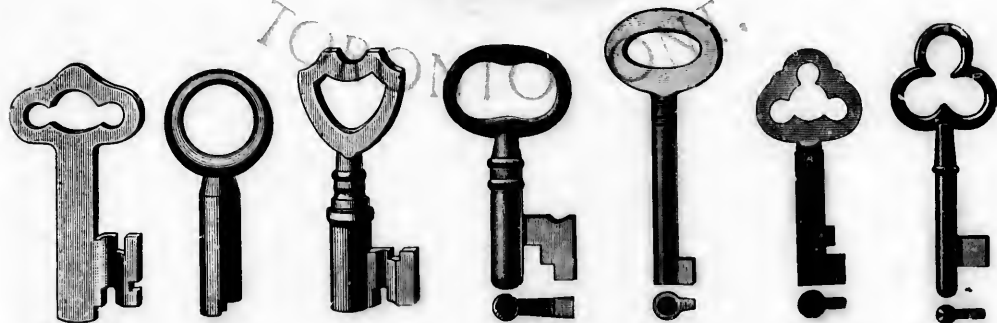

Nos. 215 313 335 5590 5376 5339 5236

Nos.....	215	313	335	5590	5376	5339	5236
Per gross.....	\$6.00	4.50	4.50	4.50	5.00	3.30	3.30

DRAWER LOCKS

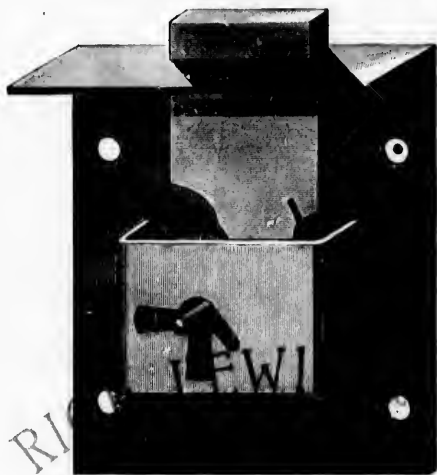

No. 638

No. 638—2½ inch, Iron, Brass Selvedge, Broad Heavy Bolt, 1 Ward, 1½ inch from Selvedge to Key Pin, per doz. \$1.80

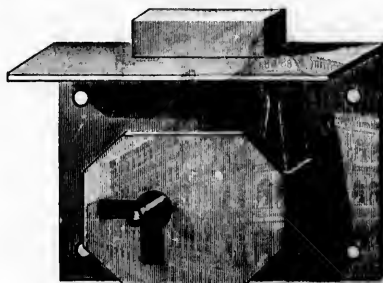

No. 411

No. 411—2½ inch, Iron, Broad Heavy Bolt, Tumbler, 2 Wards, 1 inch from Selvedge to Key Pin.....per doz. 2.00



Nos. 634 and 635

No. 634—2½ inch, Iron, Broad Bolt, 1 Ward, 1 inch from Selvedge to Key Pin.....per doz. 1.15
" 635—2½ " " Brass Selvedge, Broad Bolt, 1 Ward, 1 inch from Selvedge to Key Pin..... " 1.50
 One dozen in a box.



doz. \$0.40
 " 0.68
 " 0.40
 " 0.66



doz. 0.40
 " 0.66
 " 1.00

ch
 doz. 1.50

DRAWER LOCKS



Nos. 430 and 0430. Style of No. 431

No. 457. Style of Nos. 0482 to 0462

No. 430—2 inch,	Iron,	Solid Box,	Broad Brass Bolt,	2 Secure Levers,	$\frac{5}{8}$ inch Selvedge to Key Pin	per doz.	\$3.00
" 0430—2 "	Brass,	"	"	2 "	"	"	4.00
" 431—2 $\frac{1}{4}$ "	Iron,	"	"	2 "	"	"	3.25
" 457—2 $\frac{1}{2}$ "	Iron,	"	Broad Heavy Bolt,	2 "	"	"	3.25
" 0482—2 $\frac{1}{2}$ "	Brass,	"	"	1 "	"	"	10.00
" 0480—2 $\frac{1}{2}$ "	Brass,	"	"	3 "	"	"	7.50
" 0462—2 $\frac{1}{2}$ "	Brass,	"	Brass Bolt,	3 "	"	"	5.00

Nos. 430 to 0482 have Flat Bow Steel Keys, all different in a dozen; No. 0480, 4 changes in a dozen; No. 0462, Brass Keys, all different in a dozen.

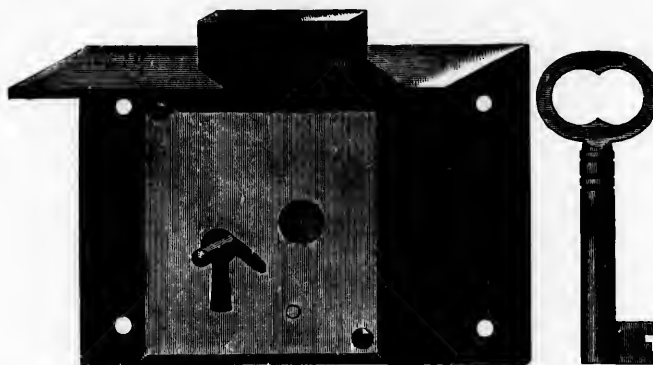

No. 469

No. 469—3 inch, Iron, Solid Square Box, Screwed, Broad Heavy Bolt, 2 Secure Levers, $1\frac{1}{8}$ inch from Selvedge to Key, Pin, Flat Bow Steel Keys, all different in a dozen..... per doz. 5.00

One dozen in a box.

DRAWER LOCKS

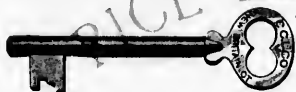
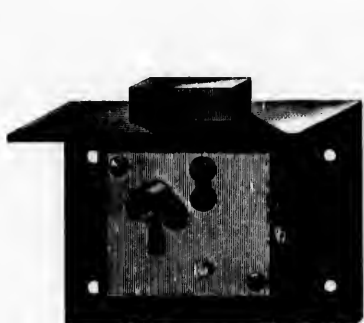

No. 0571

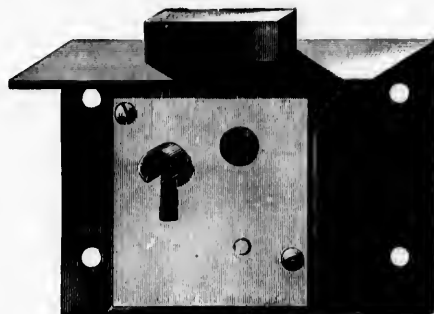

No. 0576

No. 0571—2 inch, Brass, Solid Square Box, Screwed, Broad Bolt, 2 Secure Levers, $\frac{1}{8}$ inch from Selvedge to Centre of Tube, Solid Steel Keys, all different in a dozen..... per doz. \$5.00

" 0576—2 $\frac{1}{2}$ inch, Brass, Solid Square Box, Screwed, Broad Heavy Bolt, 3 Secure Levers, $\frac{1}{8}$ inch from Selvedge to Centre of Tube, Solid Steel Keys, all different in a dozen..... per doz. 7.00

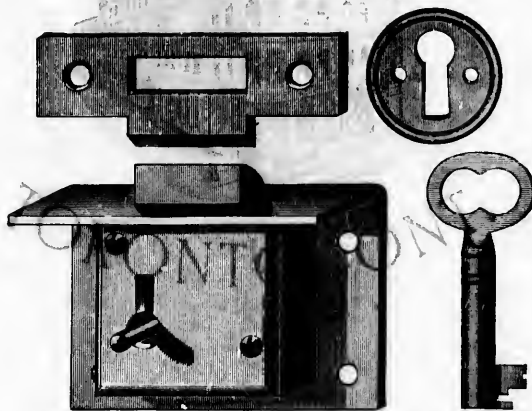

No. 0479

No. 0479—2 inch, Brass, Self-Locking, Solid Square Box, Screwed, Broad Heavy Latch Bolt, 6 Wards, $\frac{1}{8}$ inch from Selvedge to Key Pin, Bow Steel Keys, all different in a dozen..... per doz. 8.00

One dozen in a box.



doz. \$3.00
4.00
3.25
3.25
10.00
7.50
5.00

; No. 0462,

ge
z. 5.00

DRAWER LOCKS

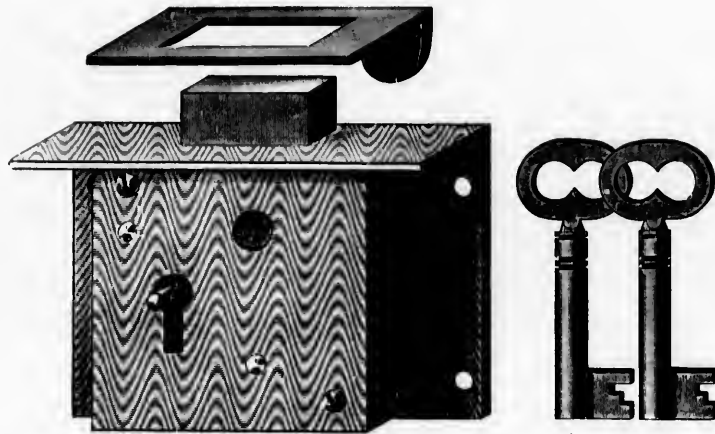

No. 0509

No. 0509—3 inch, **Brass**, Self Locking, Cast Brass Box, Screwed, Brass Strike, Broad Heavy Bolt, 3 Secure Levers, 1 inch from Selvege to Key Pin, 2 Flat Bow Brass Keys, all different in a dozen. . per doz. \$12.00

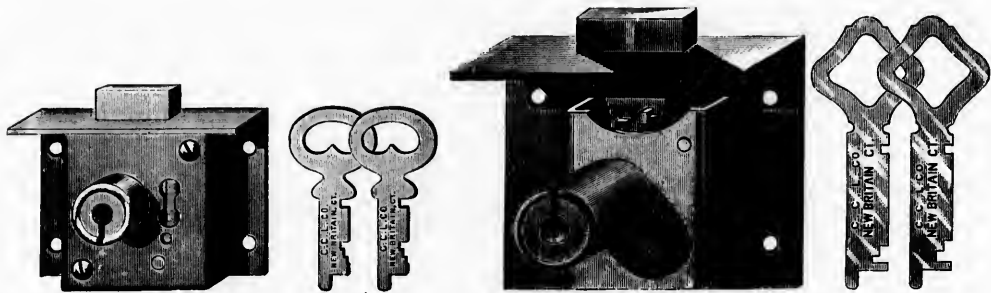

No. 590 $\frac{1}{2}$

Nos. 590 and 0590

- | | |
|--|--------|
| <p>No. 590$\frac{1}{2}$—1$\frac{1}{2}$ inch, Iron, Solid Square Box, Screwed, 3 Secure Levers, $\frac{1}{2}$ inch from Selvege to Centre of Cylinder, made for $\frac{1}{2}$ inch Wood, 2 Nickel-Plated Flat Steel Keys, all different in a dozen, per doz.</p> | \$5.00 |
| <p>“ 590—1$\frac{3}{4}$ inch, Iron, Broad Heavy Bolt, 2 Secure Levers, $\frac{3}{4}$ inch from Selvege to Centre of Cylinder, made for $\frac{3}{4}$ inch Wood, 2 Nickel-Plated Flat Steel Keys, all different in a dozen. per doz.</p> | 4.50 |
| <p>“ 0590—1$\frac{3}{4}$ inch, Brass, Broad Heavy Bolt, 2 Secure Levers, $\frac{3}{4}$ inch from Selvege to Centre of Cylinder, made for $\frac{3}{4}$ inch Wood, 2 Nickel-Plated Flat Steel Keys, all different in a dozen. per doz.</p> | 5.00 |
| <p>“ 592—2 inch, Iron, Broad Heavy Bolt, 2 Secure Levers, $\frac{1}{2}$ inch from Selvege to Centre of Cylinder, made for $\frac{1}{2}$ inch Wood, 2 Nickel-Plated Flat Steel Keys, all different in a dozen. per doz.</p> | 4.75 |
| <p>“ 0595—2 inch, Brass, Solid Square Box, Screwed, 3 Secure Levers, $\frac{1}{2}$ inch from Selvege to Centre of Cylinder, made for $\frac{3}{4}$ inch Wood, 2 Nickel-Plated Flat Steel Keys, all different in a dozen, per doz.</p> | 7.00 |
| <p>“ 0611$\frac{1}{2}$—2$\frac{1}{4}$ inch, Brass, Solid Square Box, Screwed, 3 Secure Levers, $\frac{1}{2}$ inch from Selvege to Centre of Cylinder, made for $\frac{3}{4}$ inch Wood, 2 Nickel-Plated Flat Steel Keys, all different in a dozen, per doz.</p> | 7.50 |

One dozen in a box.

DRAWER LOCKS

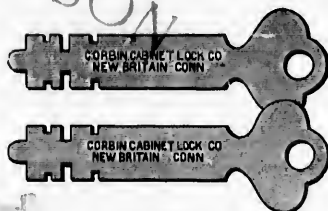
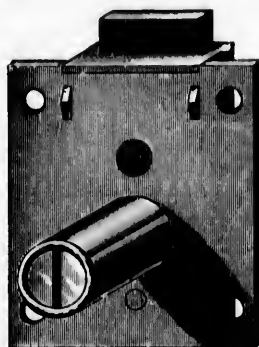
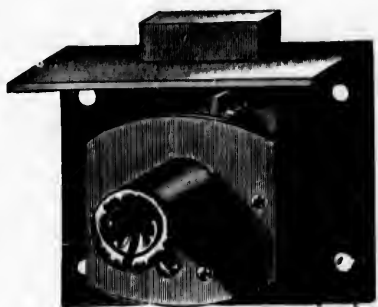

No. 0675

No. 699

- No. 0675**—2 inch, Brass, Cast Brass Box and Cylinder, Screwed, 3 Secure Levers, $\frac{1}{4}$ inch from Selvedge to Centre of Cylinder, made for $\frac{1}{4}$ inch Wood, 2 Nickel-Plated Flat Steel Keys, all different in a dozen..... per doz. \$8.00
- 699**— $1\frac{1}{2}$ x 2 inch, Iron, Broad Bolt, 2 Secure Levers, $\frac{1}{4}$ inch from Selvedge to Centre of Cylinder, made for $\frac{1}{4}$ inch Wood, 2 Nickel-Plated Flat Steel Keys, all different in a dozen..... per doz. 4.50

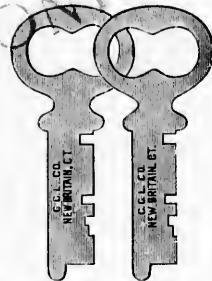
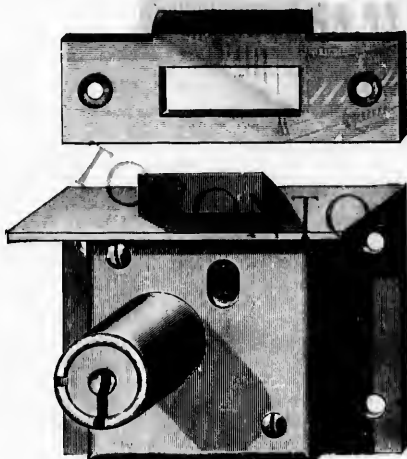

No. 0601 $\frac{1}{2}$

- No. 0601 $\frac{1}{2}$** —2 $\frac{1}{4}$ inch, Brass, Solid Square Box, Heavy Latch Bolt, Brass Strike, 3 Secure Levers, $\frac{1}{4}$ inch from Selvedge to Centre of Cylinder, made for $\frac{1}{4}$ inch Wood, 2 Nickel-Plated Flat Steel Keys, all different in a dozen, Cylinders cut for both Cupboard and Drawer..... 9.00

One dozen in a box.

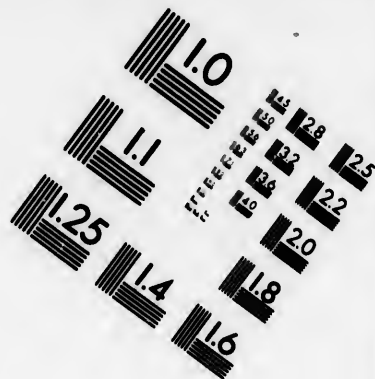
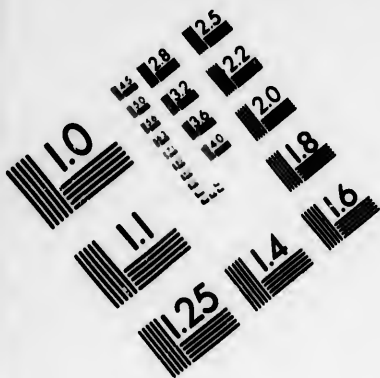

**IMAGE EVALUATION
TEST TARGET (MT-3)**

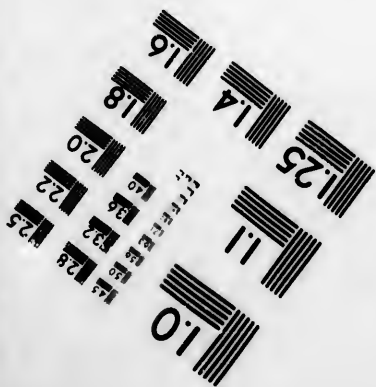
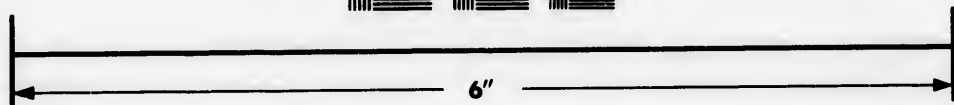
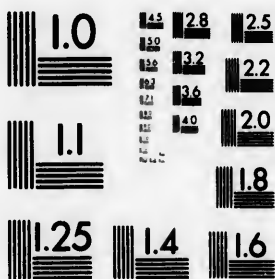

**Photographic
Sciences
Corporation**

23 WEST MAIN STREET
WEBSTER, N.Y. 14580
(716) 872-4503

1.4
1.8
2.5
3.2
4.0
5.0
6.3
8.0
10.0
12.5
16.0
20.0
25.0
31.5
40.0
50.0
63.0
80.0
100.0
125.0
160.0
200.0
250.0
315.0
400.0
500.0
630.0
800.0
1000.0

10
100
1000

DRAWER LOCKS

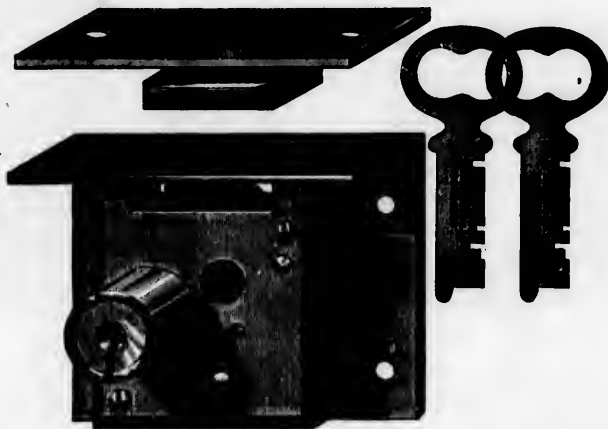

No. 0681

No. 0681— $2\frac{1}{2}$ inch, Brass, Self-Locking, Solid Square Box, Screwed, Heavy Cast Brass Strike, 3 Secure Levers, $\frac{3}{4}$ inch from Selvege to Centre of Cylinder, made for $\frac{1}{2}$ inch Wood, 2 Nickel-Plated Flat Steel Keys, all different in a dozen per doz. **\$9.00**

One dozen in a box.

CYLINDER LOCKS, ALL BRASS, PIN TUMBLER

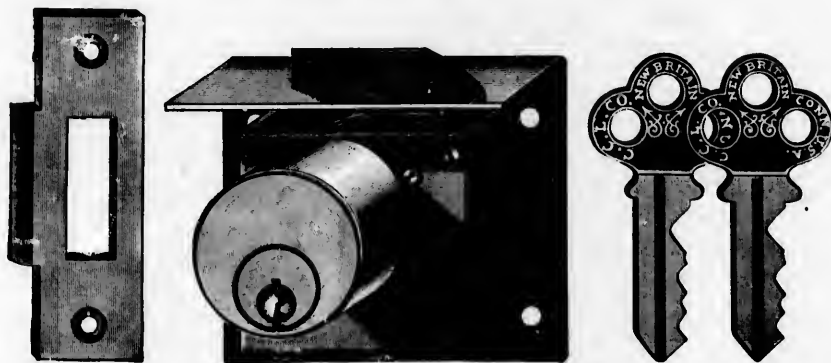

No. 0685 $\frac{1}{2}$

SELF-LOCKING

No. 0685 $\frac{1}{2}$ —Corbin's, $2\frac{1}{2} \times 1\frac{1}{4}$ inch, $\frac{3}{4}$ inch from Selvege to Centre of Cylinder, made for $\frac{1}{2}$ inch Wood, 2 German Silver Keys, no two Locks alike per doz. **17.00**

" **563S**—Yale, $2\frac{1}{2} \times 1\frac{1}{4}$ inch, 1 inch from Selvege to Centre of Cylinder, made for $\frac{1}{2}$ inch Wood, 2 German Silver Yale Paracentric Keys, no two Locks alike per doz. **17.80**

One in a box.

ROLLING TOP DESK LOCKS

PATENT MORTISE, SELF-LOCKING

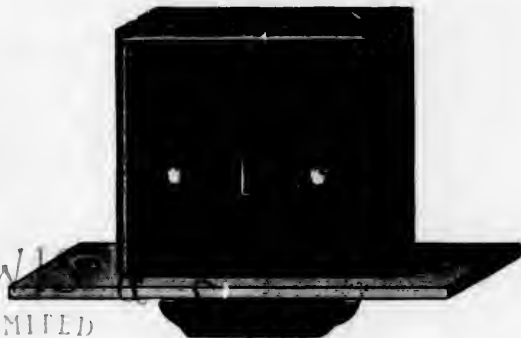
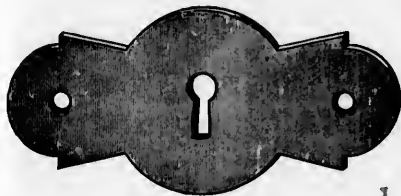

No. 47C

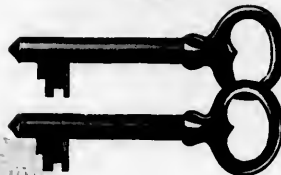

RICE LEWIS
LIMITED

No. 47C—3 inch, Brass Selvedge and Strike, Patent Self-Closing Striker, Gilt, Brass, Plain Escutcheon, 4 Secure Levers, 2 Nickel-Plated Steel Keys, all different in a dozen.....per doz. \$8.00
One dozen in a box, with Screws.

MORTISE DESK LOCK

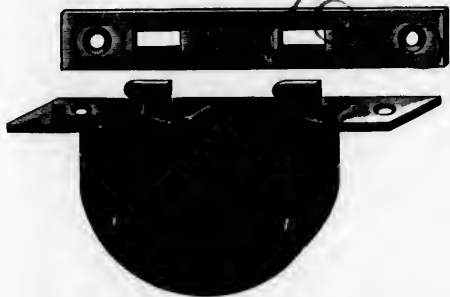

No. 60

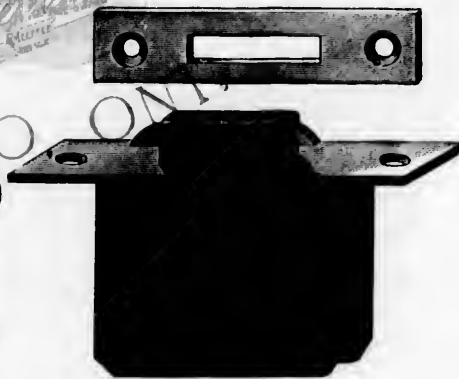

No. 882

No. 60—2½ inch, Mortise, Brass Selvedge, Bolts and Strike, Fine Flat Bow Keys.....per doz. 2.00
" 882—2½ " " " " " Double Hook Bolt, Fine Flat Bow Keys " 3.00

No. 00, ¾ inch from Selvedge to Key Pin; No. 882, ¾ inch.

One dozen in a box.

\$9.00

7.00

7.80

WARDROBE OR CUPBOARD LOCKS



No. 712. Style of No. 714



LEWIS &
LIMITED



No. 725. Style of No. 724

Keys all different in a dozen.

No.	Size	Material	Action	Lever	Key	Per doz.
No. 712	3 1/2 x 2	Iron	Solid Square Box, Iron Bolt	Shoots Both Ways, 2 Secure	Lever, Steel Key	\$2.25
" 714	4 x 2 1/2	Iron	"	"	"	2.50
" 724	3 x 1 1/2	Iron	"	"	Brass	4.00
" 725	3 1/2 x 2	Iron	"	"	Iron	4.00

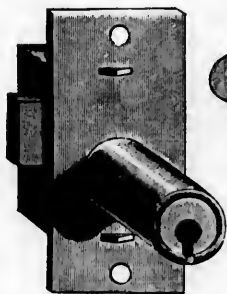

Nos. 749 and 0749



Nos. 750 to 0751



Keys all different in a dozen.

No.	Size	Material	Action	Lever	Key	Per doz.
No. 749	1 1/2 x 1 1/4	Iron	Brass Bolt	Shoots Right and Left, 2 Secure	Lever, 2 Keyed	5.50
" 0749	1 1/2 x 1 1/4	Brass	"	"	"	6.50
" 750	2 1/2 x 1 1/2	Iron	"	"	"	6.00
" 0750	2 1/2 x 1 1/2	Brass	"	"	"	8.00
" 751	3 x 1 1/2	Iron	"	"	"	7.00
" 0751	3 x 1 1/2	Brass	"	"	"	9.00

Locks 749, 0749 have 1/2 inch Cylinder; all others assorted, 3/4, 1 and 1 1/2 inch.
One dozen in a box.

\$1.50
 2.00
 1.00
 2.25
 1.00
 1.02
 1.87

\$5.00
 4.00

5.50
 5.00
 0.38
 5.25

WARDROBE OR CUPBOARD LOCKS

ALL BRASS, PIN TUMBLER



No. 0764



- | | | |
|----------|---|------------------|
| No. 0764 | —Corbin, 2 x 1½ inch, Heavy Brass Bolt, for either Right or Left Hand, 2 German Silver Keys, no two Locks alike..... | per doz. \$18.85 |
| " 511 | —Yale, 2 x 1½ inch, Heavy Brass Bolt, for either Right or Left Hand, 2 German Silver Yale Paracentric Keys, no two Locks alike..... | per doz. 10.35 |

CHEST LOCKS

ALL BRASS, PIN TUMBLER

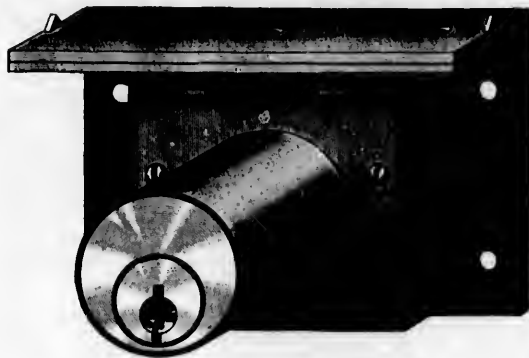

No. 0170



- | | | |
|----------|--|----------------|
| No. 0170 | —Corbin, 3 x 1½ inch, 1½ inch from Selvege to Centre of Cylinder, for 1½ inch Wood, 2 German Silver Keys, no two Locks alike..... | per doz. 27.25 |
| " 521 | —Yale, 4 x 2 inch, 1½ inch from Selvege to Centre of Cylinder, for 1½ inch Wood, 2 German Silver Paracentric Keys, no two Locks alike..... | per doz. 33.65 |

One in a box.

SHOW CASE LOCKS



No. 02398

No. 02398— $2\frac{1}{2}$ x 1 inch, Cast Bronze Metal, Spring Latch, 1 Tumbler, Bronze Strike and Key, Finely Finished and Lacquered..... per doz. \$10.00

RICE LEWIS & SON
LIMITED
CASH BOX LOCKS

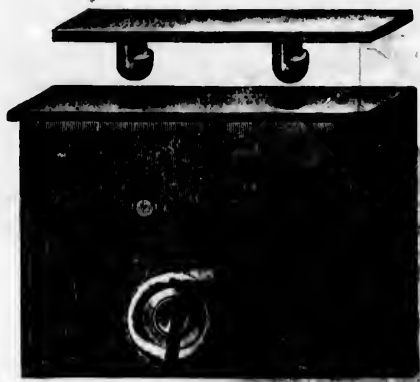

No. 827

No. 826— $2\frac{1}{2}$ inch, Iron, Brass Double Link and Cylinder, 2 Secure Levers, 1 inch from Selvege to Centre of Cylinder, 2 Nickel-Plated Flat Steel Keys, all different in a dozen..... per doz. 4.00

No. 827— $2\frac{1}{2}$ inch, Iron, Brass Double Link and Cylinder, 3 Secure Levers, $1\frac{1}{4}$ inch from Selvege to Centre of Cylinder, 2 Nickel-Plated Flat Steel Keys, all different in a dozen..... per doz. 4.50

TORONTO, ONT.

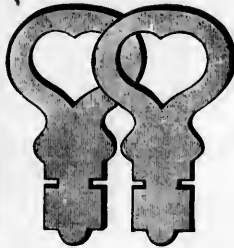
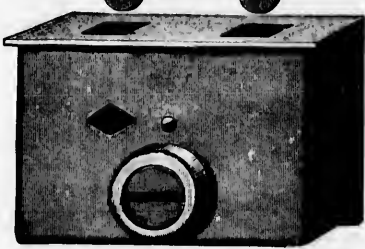

No 828

No. 828—2 inch, Iron, Double Link, 1 Tumbler, 1 inch from Selvege to Centre of Cylinder, 2 Flat Steel Keys..... per doz. 2.00

One dozen in a box.

18.85
10.35

7.25
3.65

CHEST LOCKS



No. 01. Style of Nos. 002 and 04



No. 34. Style of Nos. 36 and 38

No. 01	—1½	inch, Brass,	¾	inch from Selvedge to Key Pin, Single Link	per doz.	\$0.75
"	002	—1½	"	"	"	"	0.00
"	04	—2	"	"	"	"	1.00
"	34	—2½	"	"	"	"	2.12
"	36	—3	"	"	"	"	2.87
"	38	—3½	"	"	"	"	2.75



No. 0100. Style of Nos. 104 and 106

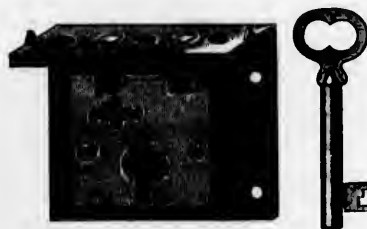

No. 0120

No. 0100	—1½	inch, Brass, Solid Box, 2 Secure Levers,	¾	inch from Selvedge to Key Pin	per doz.	3.50
"	104	—2½	"	"	"	"	3.50
"	106	—3	"	"	1½	"	4.00
"	0120	—1½	"	"	¾	"	6.75

Nos. 0100 to 100 Flat Bow Keys, No. 0120 Solid Steel Key, all different in a dozen.

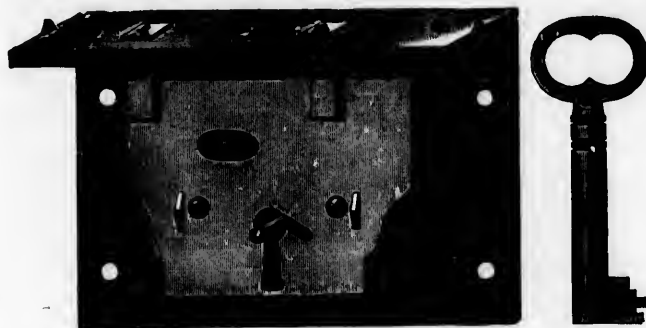

No. 70. Style of Nos. 71 and 74

No. 70	—3	inch, Iron, 2 Secure Levers,	1½	inch from Selvedge to Key Pin	per doz.	4.00
"	71	—3½	"	"	"	"	4.25
"	74	—4	"	"	"	"	4.75

Flat Bow Keys, all different in a dozen.

One dozen in a box.

CHEST LOCKS

SELF-LOCKING



No. 82

- No. 82—4 inch, Iron, Solid Box, Secret Wards, Brass Escutcheon, $1\frac{1}{2}$ inch from Selvege to Key Pin, Double Bitted Keys, all different..... per doz. \$0.00
- " 83—4 inch, Iron, Solid Box, Secret Wards, Brass Escutcheon, $1\frac{1}{2}$ inch from Selvege to Key Pin, Double Bitted Keys, all different..... 8.00

Half-dozen in a box.

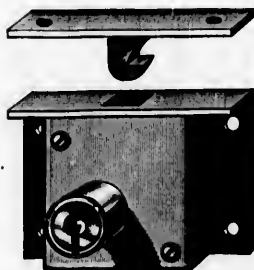

No. 0148



No. 143. Style of No. 0144

- No. 0148— $1\frac{1}{2}$ inch, Brass, Solid Box, 4 Secure Levers, Self-Locking, $\frac{3}{4}$ inch from Selvege to Centre of Cylinder, made for $\frac{1}{2}$ inch Wood, 2 Nickel-Plated Flat Steel Keys, all different in a dozen, per doz..... 6.00
- " 143— $2\frac{1}{2}$ inch, Iron, Solid Box, 3 Secure Levers, $\frac{1}{4}$ inch from Selvege to Centre of Cylinder, made for $\frac{3}{4}$ inch Wood, 2 Nickel-Plated Flat Steel Keys, all different in a dozen..... per doz. 9.00
- " 0144— $2\frac{1}{2}$ inch, Brass, Solid Box, 4 Secure Levers, 1 inch from Selvege to Centre of Cylinder, made for $\frac{3}{4}$ to $1\frac{1}{2}$ inch Wood, 2 Nickel-Plated Flat Steel Keys, all different in a dozen..... per doz. 12.00

One dozen in a box.

POST OFFICE BOX LOCKS

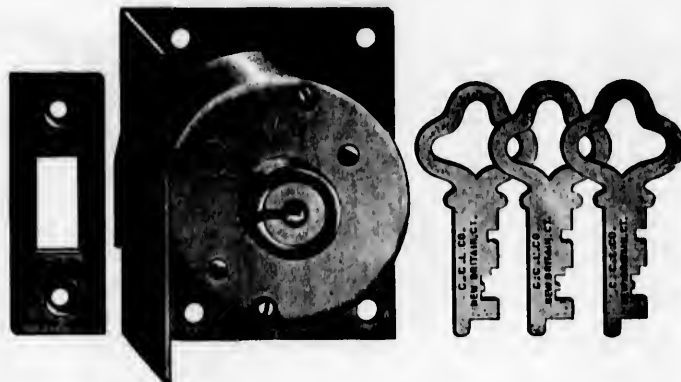

No. 0589;— $\frac{1}{2}$ inch, Brass, Self Locking, 4 Secure Levers, 3 Keys to each Lock, for $\frac{1}{4}$ inch Wood . . . per doz. \$0.00

One dozen in a box.

COMPARATIVE LIST OF CABINET LOCKS

CORBIN	EAGLE	KEYED	PRICE PER DOZ.	CORBIN	EAGLE	KEYED	PRICE PER DOZ.	CORBIN	EAGLE	KEYED	PRICE PER DOZ.
01	42	12	\$0.75	469	048	12	\$5.00	703	417	12	\$1.00
002		12	0.90	0478	205	12	8.00	0703	418	12	2.25
04	35	12	1.00	0480	0220	12	7.50	704	510	12	1.00
34	100	12	2.12	0482	0224	12	10.00	705	383	12	1.02
36	100	12	2.37	0509		24	12.00	707	630	12	9.50
38	83	12	2.75	0571		12	5.00	0707	637	12	13.25
47C	1804C	24	8.00	0576	1218	12	7.00	709	500	12	1.87
60	200	12	2.00	0589		36	9.00	712	174	12	2.25
70	216	12	4.00	590	0000	24	4.50	714	173	12	2.50
71	217	12	4.25	590A		24	5.00	0731	0000	12	5.00
74	01	12	4.75	0590	0060	24	5.00	732	0005	12	4.00
82	210	12	6.00	592	1079	24	4.75	0732	0004	12	5.50
83	218	12	8.00	0595	0002-3T	24	7.00	734	148	12	4.00
0100	472	12	3.50	0601	0004	24	9.00	735	157	12	4.00
104	427	12	3.50	0611	0101	24	7.50	741	1208	12	5.00
106	410	12	4.00	0623	007	12	1.00	0741	1202	12	6.38
0120	1084	12	6.75	626	72	3	0.40	742	500	12	5.25
143	1058	24	9.00	626	72	12	0.06	749	1055	24	5.50
0144	6071	24	12.00	626	1000	3	0.40	0749	1050	24	6.50
0148		24	6.00	634	1000	12	0.06	750	7008	24	6.00
406	440	3	0.40	634	161	12	1.15	0750	0008	24	8.00
406	440	12	0.00	635	180	12	1.50	751	7074	24	7.00
411	312	12	2.00	638	240	12	1.80	0751	0074	24	9.00
430	001	12	3.00	0675	01001	24	6.00	826		24	4.00
0430	70	12	4.00	0681	01028	24	9.00	827		24	4.50
431	177	12	3.25	689	1848	24	4.50	828	624	24	2.00
457	237	12	3.25	700	500	12	1.50	861	431	12	1.50
0462	413	12	5.00	0700	508	12	2.00	882	193	12	3.00

TRUNK LOCKS



No. 1431—3½ inch, Iron, Black Japanned,
Brass Drop and Escutcheon.....per doz. \$1.05

" 1432—3½ inch, Iron, Black Japanned,
Brass Drop and Escutcheon, Fancy, Solid Mal-
leable Hasp.....per doz. 1.15

d & SON
One dozen in a box.

Nos. 1431 and 1432

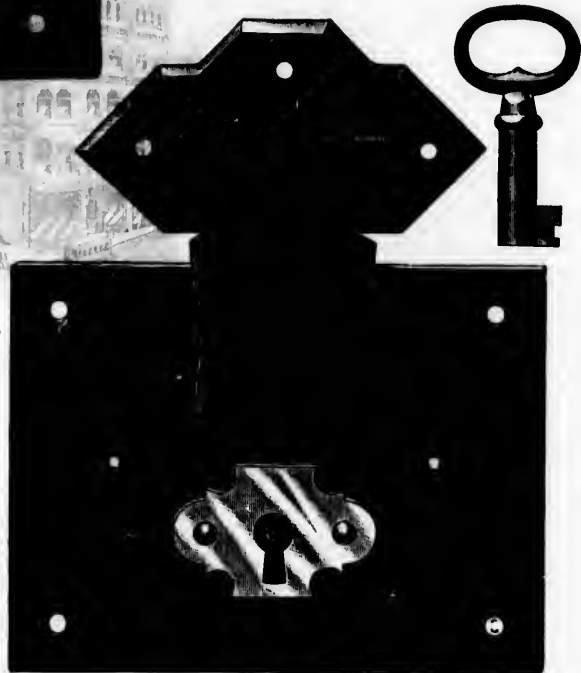

No. 1434—3½ inch, Iron, Black Japanned,
Brass Escutcheon, Malleable
Spring Hasp.....per doz. \$1.80

One dozen in a box.

TORON

No. 1434

0.00

0.00

0.00
0.25
0.50
0.75
1.00
1.25
1.50
1.75
2.00
2.25
2.50
2.75
3.00
3.25
3.50
3.75
4.00
4.25
4.50
4.75
5.00

TRUNK LOCKS

No. 1491—4 inch, Iron, Red Japanned,
 Brass Drop and Escutcheon,
 Solid Stop Hasp, Tumbler and
 Ward, Flat Bow Keys...per doz. \$6.25

One dozen in a box.

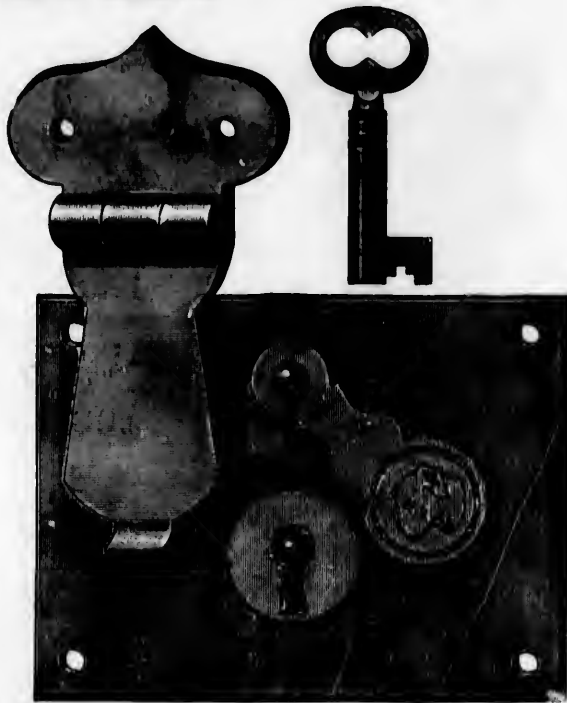

No. 1491



No. 1009

No. 1009—5½ x 3¼ inch, Extra
 Heavy, Brassed Frame,
 Brassed Centre, 2 Secure
 Levers, Flat Bow Steel
 Keys, 3 changes in a dozen,
 per doz. \$10.25

One dozen in a box.



T
 No. 1224
 " 1234
 " 1254



SURFACE TRUNK LOCKS

TIN-PLATE TINNED LOCKS

No. 1225—3 inch	per doz.	\$2.35
" 1230—3½ "	"	2.50
" 1250—4 "	"	2.75

With Spring to throw open Hasp when opened.

One dozen in a bag.

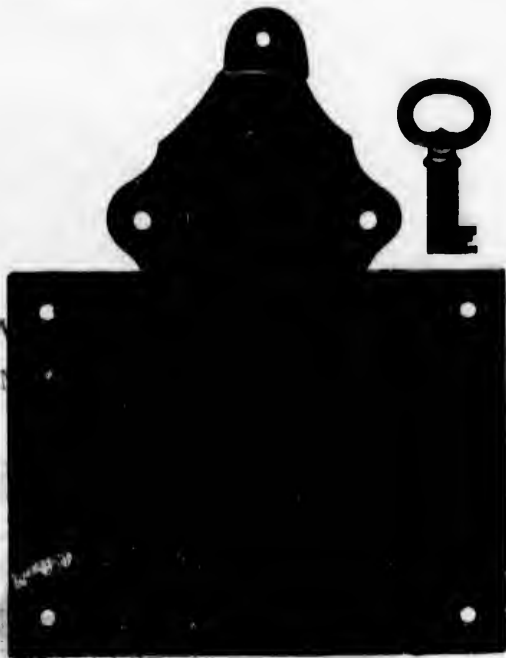

No. 1230. Style of Nos. 1225 and 1250



No. 1122

No. 1122—5½ inch, Iron, Tinned Frame, Japanned Hasp per doz. \$3.30

With Spring to throw open Hasp when opened.

One dozen in a box.

10.25

TRUNK LOCKS

BRASS SECURE LEVER

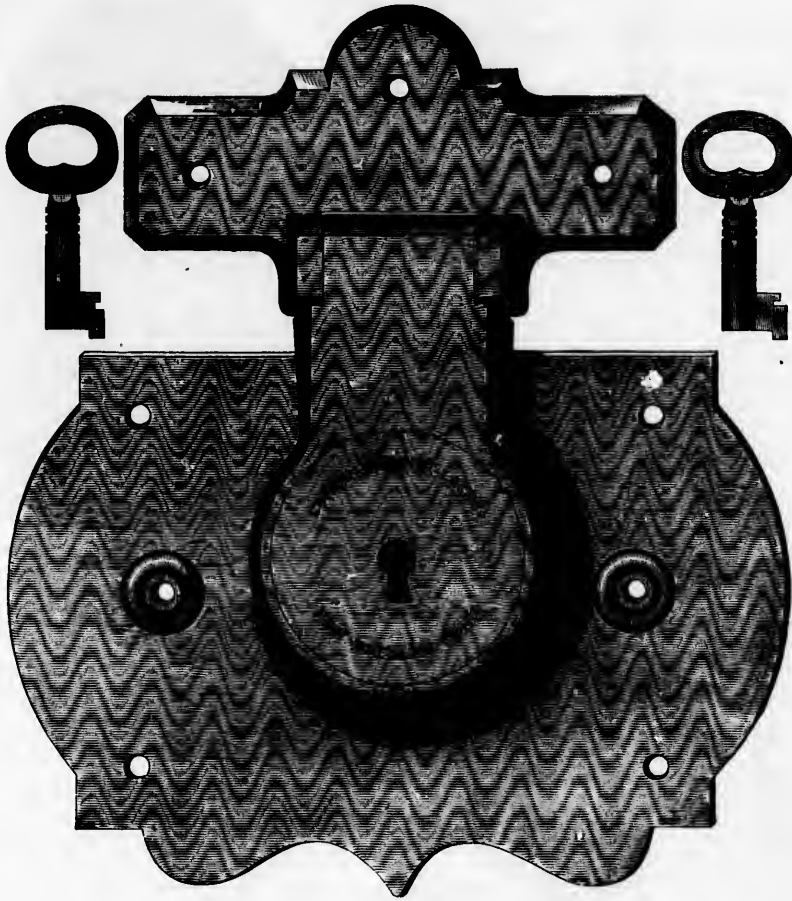

No. 1038

No. 1038—5 inch Brass, Cast Brass Hasp, 2 Secure Levers and 2 Wards, Spring throws open Hasp when Unlocked, 6 Changes in a dozen, 2 Flat Bow, Steel Keys, Finished in Fancy Patterns.. per doz. \$15.00

One dozen in a box,

TRUNK LOCKS

WROUGHT STEEL SECURE LEVER

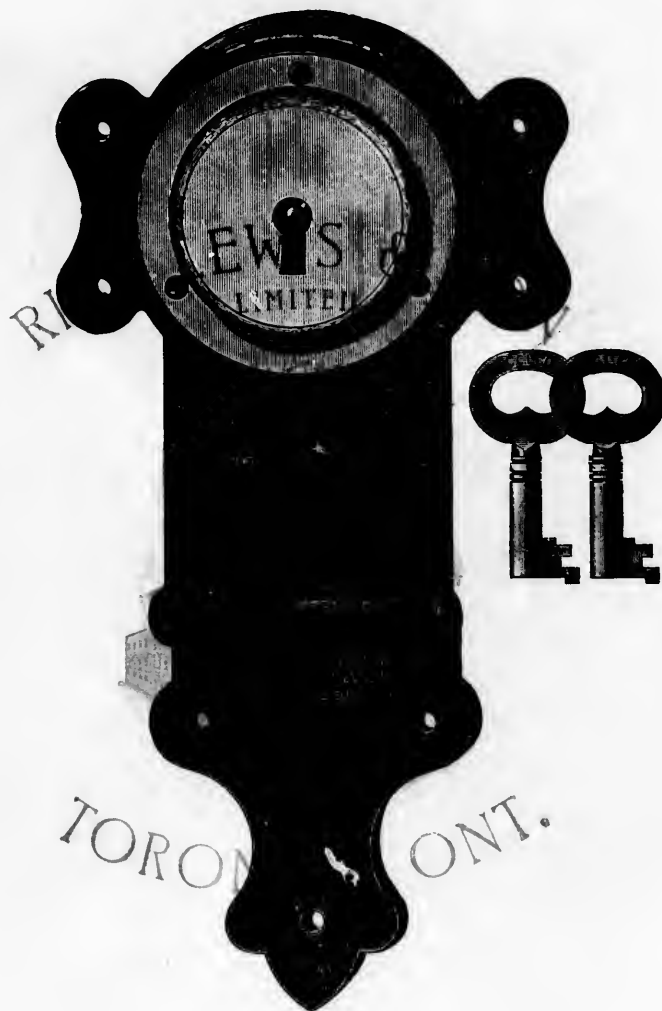

No. 01048½

No. 01048½—Steel, Not Polished, Brass Plated, 1 Secure Lever.....per doz. \$8.75

One dozen in a box.

\$15.00

TRUNK LOCK AND CATCH

COMBINED



No. 1107, LOCKED

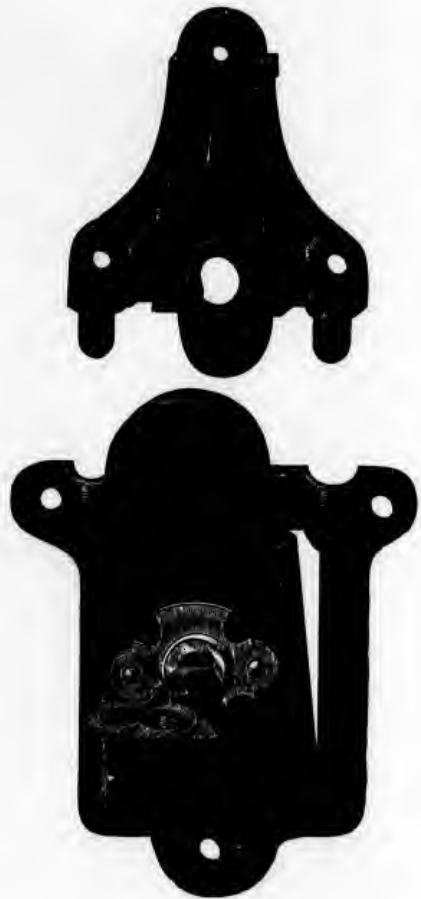

No. 1107, UNLOCKED

No. 1107—4½ x 1½ inch, iron, Tinned Frame, Japanned Centre, with Spring to throw open Hasp when Unlocked, 3 Changes in a dozen.....per doz. \$2.90

No. 1800—
" 1805—
" 1810—

TRUNK CATCHES

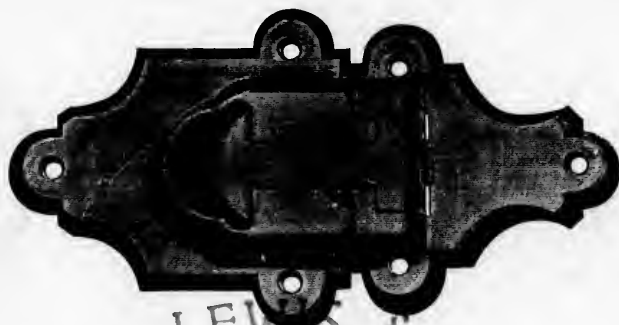

RICE LEWIS & SON
 No. 1800
 LIMITED

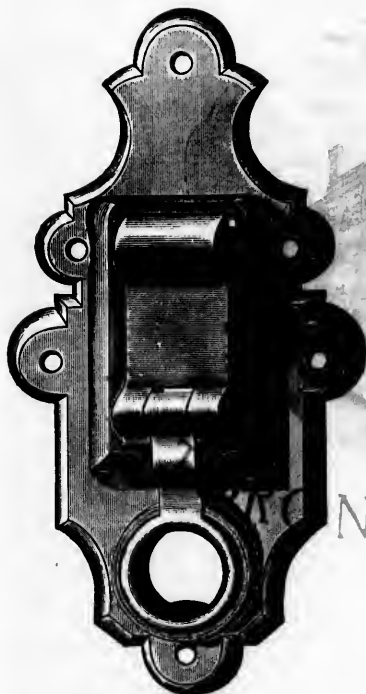

No. 1805

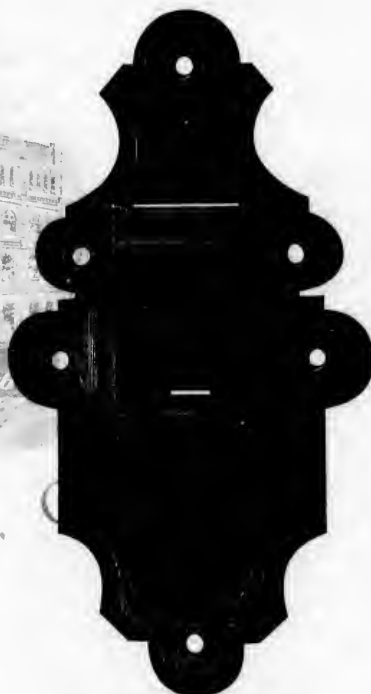

No. 1810

TO. C

No. 1800—4 inch, Malleable Iron, Black Japanned.....	per doz.	\$1.00
" 1805—4½ " " " " "	"	1.25
" 1810—4½ " " " " "	"	1.25

hen
 doz. \$2.90

PADLOCKS

WROUGHT BRASS. FOR BAGS, SMALL BOXES, DOG COLLARS, ETC.

Full size cuts.

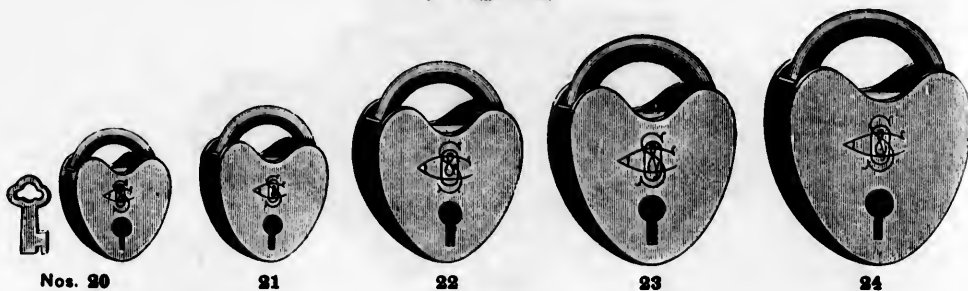

Nos. 20

21

22

23

24

WITH FLAT STEEL KEY

Nos.....	20	21	22	23	24
Per dozen.....	\$4.50	4.50	5.00	5.50	6.00
No. 20—Nickel-Plated (same size as No. 20)				per doz.	\$5.75

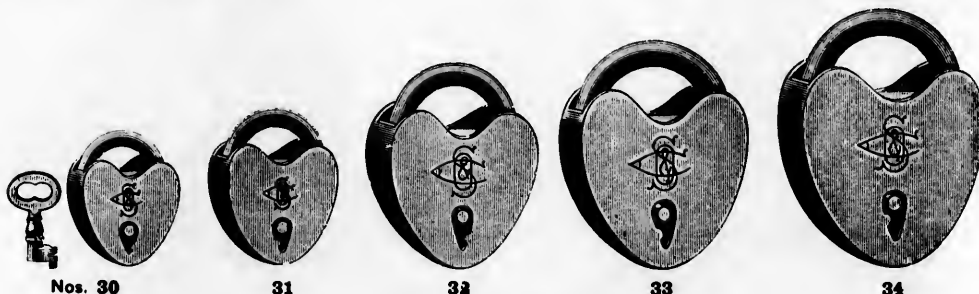

Nos. 30

31

32

33

34

WITH STEEL BIT KEY

Nos.....	30	31	32	33	34
Per dozen.....	\$4.50	4.50	5.00	5.50	6.00

One dozen in a box.



No. 1

FINE SCANDINAVIAN CHARM LOCK

No. 1	per doz.	Glit.	Nickeled.
" 2	"	\$2.85	2.85

One dozen in a box.



No. 2

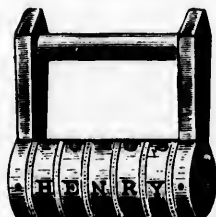

LETTER PADLOCKS

No. 2844

BRASS ROLLS

4 Rolls.....	per doz.	\$3.00
5 "	"	7.50

One dozen in a box.



No. 0900—
" 0902—
" 0904—
" 0906—
" 902—
" 904—
" 906—



No. 0908—
" 0910—
" 908—
" 910—

GEM PADLOCKS

SPRING SHACKLE, SELF-LOCKING



No. 8900—Brass, $\frac{3}{4}$ inch, Flat Steel Key	per doz.	\$2.25
" 8902—Brass, 1 " " " assorted, 4 changes in a dozen	"	2.25
" 904—Brass, $1\frac{1}{2}$ " " " 4 " "	"	2.50
" 906—Brass, $1\frac{1}{2}$ " " " 6 " "	"	3.00
" 902—Iron, Japanned, 1 inch, Flat Steel Key	"	1.20
" 904—Iron, " $1\frac{1}{2}$ " " "	"	1.25
" 906—Iron, " $1\frac{1}{2}$ " " "	"	1.85



No. 908—Brass, $1\frac{1}{2}$ inch, Flat Steel Key	per doz.	3.50
" 910—Brass, 2 " " "	"	4.00
" 908—Iron, Japanned, $1\frac{1}{2}$ inch, Flat Steel Key	"	1.50
" 910—Iron, " 2 " " "	"	2.00

One dozen in a box.

PADLOCKS

Full size cuts.

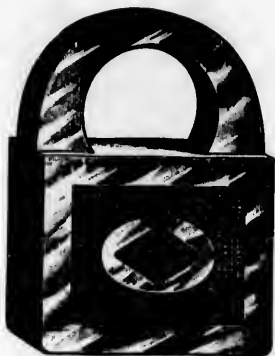

No. 303



No. 76



No. 303—Aluminum Bronze, Spring Shackle, 2 Flat Steel Keys.....per doz. \$1.00
 " 76—Tiger, Steel, Dark Finish, Spring Shackle, 2 Flat Steel Keys..... " 3.25

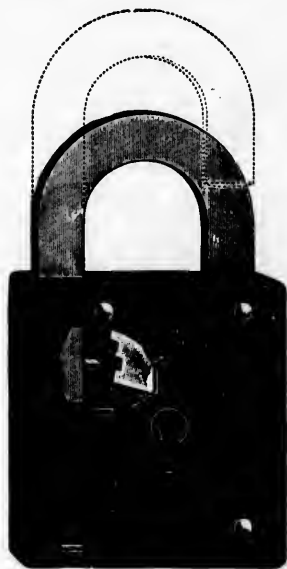

Nos. 44 and 45. Style of No. 993½



No. 96



No. 44 —Jackson, Steel, Dark Finish, Spring Shackle, 3 Levers, 2 Flat Steel Keys.....per doz. 2.80
 " 45 — " Brass, Spring Shackle, 3 Levers, 2 Flat Steel Keys..... " 3.75
 " 993½—Corbin, Steel, Japanned Finish, Spring Shackle, 4 Levers, 2 Flat Steel Keys..... " 2.05
 " 96 —Protector, Steel, Dark Finish, " " 3 " 2 " " " 2.50

Half-dozen in a box.

No. 1
 " 25
 " 34

No. 265
 " 357

No. 997
 " 915
 " 0915

PADLOCKS



No. 1—Champion, 2½ inch, Bronze Metal, 6 Levers, 2 Flat Steel Keys	per doz.	\$7.50
" 25—Harvard, 2½ " " " 0 " 2 " "	"	6.40
" 24— " 2 " " " 4 " 2 " "	"	5.25



No. 265. Half size.

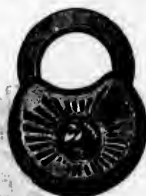

No. 357. Half size.

No. 265—1½ inch, Bronze Metal, Spring Shackle, 2 Flat Steel Keys	per doz.	4.15
" 357—1½ " " " " 2 " " "	"	3.00



No. 997



Nos. 915 and 0915



No. 997—Iron, Bright Finish, Self Locking, Heavy Spring Shackle, 4 Secure Levers, 1 Cut Steel Key, per doz.	3.15
" 915—Iron, " " " " 6 " 1 " " "	3.25
" 0915—Brass, Plain Finish, " " " " 6 " 1 " " "	5.05

WROUGHT IRON TUMBLER PADLOCKS



No. 122



No. 200



No. 122—2 inch, Iron, with Self-Locking Spring Shackle, Revolving Key Pin, 1 Key.....	per doz.	\$3.40
" 200—2½ " Plain, without Drop, 1 Key	"	2.70



No. 201



No. 203



No. 201—2½ inch, Plain, with Brass Drop, 1 Key.....	per doz.	3.25
" 203—2½ " with Brass Bushing, 1 Key.....	"	3.75

One dozen in a box.

No. 204
" 215
" 216
" 216

No. 301
" 302

WROUGHT IRON TUMBLER PADLOCKS



No. 404



Nos. 716 and 718

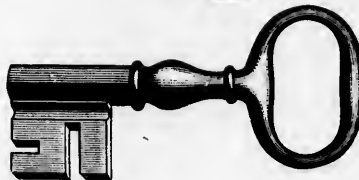
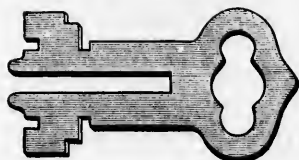

No. 404—2½ inch, Brass Bushing, Double Chamber, Revolving Key Pin.....	per doz.	\$ 7.90
" 716—3 " " Drop and Bushing, Solid Brass Wheel, with Double Plates, 12 Changes, 1 Key.....	"	12.50
" 718—3 " Same as 716, only with Single Plates, 1 Key.....	"	10.00
" 716—3 " In sets of 6, all different, with 1 Master Key.....	per set	6.75

Half-dozen in a box.

STORE DOOR HANDLES

WITH MORTISE LOCK



Key No. 471



11 3/4 x 2 inch. Two-third size cut.

SET No. 4627. Flat Front Lock not shown.

No. 4627	—Bronze-Plated, (10 Finish) Rabbeted Front Lock, Double Handles, Plate 11 3/4 x 2 inch.....	per set	\$5.50
" 3726	—Bronze Metal, Flat Front Lock, Double Handles, Plate 14 1/2 x 2 1/2 inch.....	"	7.00
" 3727	— " " Rabbeted Front Lock, Double Handles, Plate 14 1/2 x 2 1/2 inch.....	"	8.00
" 3727	—Amber Bronzed, " " " " " 14 1/2 x 2 1/2 ".....	"	4.50

In ordering state Hand required. One set in a box.

\$ 7.90
12.50
10.00
6.75

STORE DOOR HANDLES WITH MORTISE LOCK

P. & F. CORBIN'S



No. 1117, $2\frac{1}{2} \times 12\frac{1}{2}$ inch.



No. 186 $\frac{1}{2}$, Flat Front.
 " 187 $\frac{1}{2}$, Rabbeted Front.
 Size, $4\frac{1}{2} \times 3$ inch.

No. 1117 \times 186 $\frac{1}{2}$ —Bronze Metal, Flat Front Lock, Double Handles, Plate $12\frac{1}{2} \times 2\frac{1}{2}$ inch..... per set \$7.80
 " 1117 \times 187 $\frac{1}{2}$ — " Rabbeted Front Lock, Double Handles, Plate $12\frac{1}{2} \times 2\frac{1}{2}$ inch..... " 8.90



No. 1117 $\frac{1}{2}$, $2\frac{1}{2} \times 12\frac{1}{2}$ inch.



No. 188, Flat Front.
 " 189, Rabbeted Front.
 Size, $5 \times 3\frac{1}{2}$ inch.

No. 1117 $\frac{1}{2}$ \times 188—Bronze Metal, Flat Front Cylinder Lock, Double Handles, Plate $12\frac{1}{2} \times 2\frac{1}{2}$ inch..... per set 12.20
 " 1117 $\frac{1}{2}$ \times 189— " Rabbeted Front Cylinder Lock, Double Handles, Plate $12\frac{1}{2} \times 2\frac{1}{2}$ inch.. " 16.20

In ordering state Hand required. One set in a box.

No. 62
 " 62

STORE DOOR LATCHES

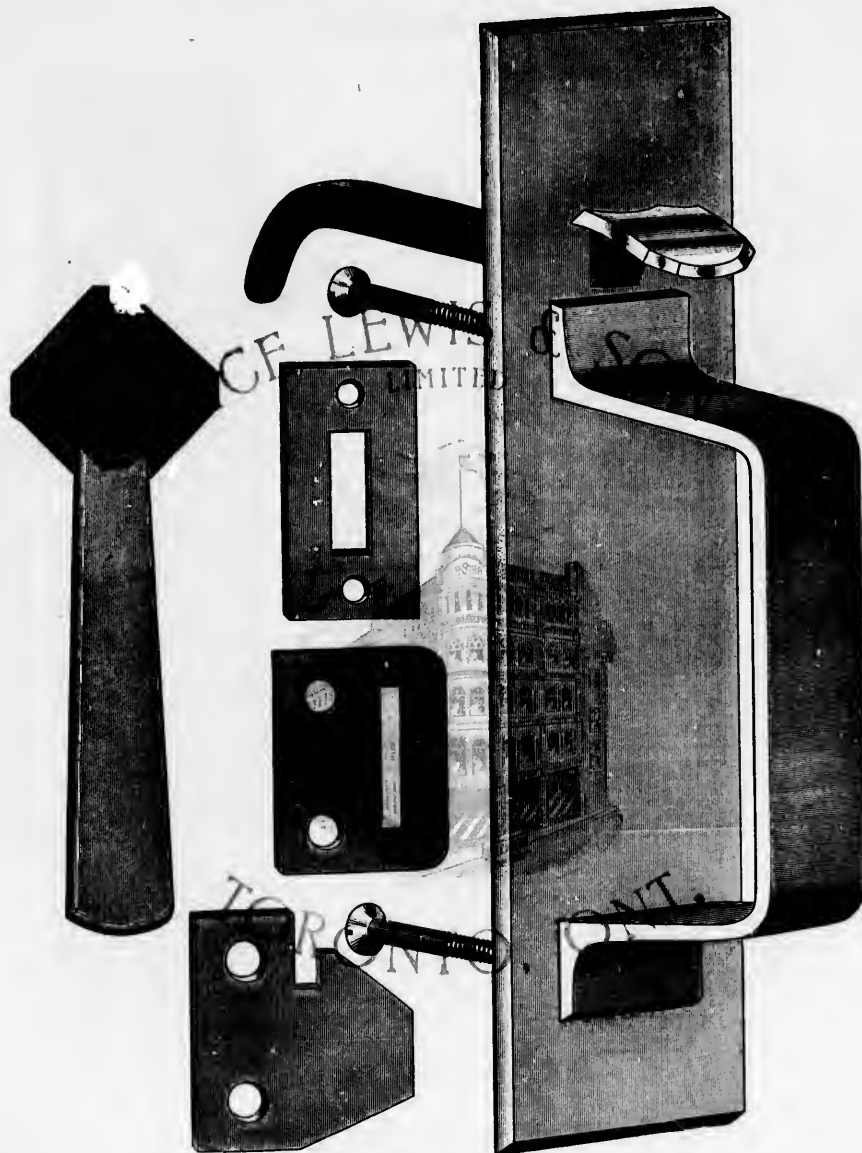

Three-quarter size cut.

No. 626—Bronze Metal, Polished, Oblique, Right or Left Hand.....	per set	\$2.30
" 628—Same as above, only heavier.....	"	4.00

Two sets in a box.

\$7.50
8.00

2.20
6.20

STORE DOOR LATCHES

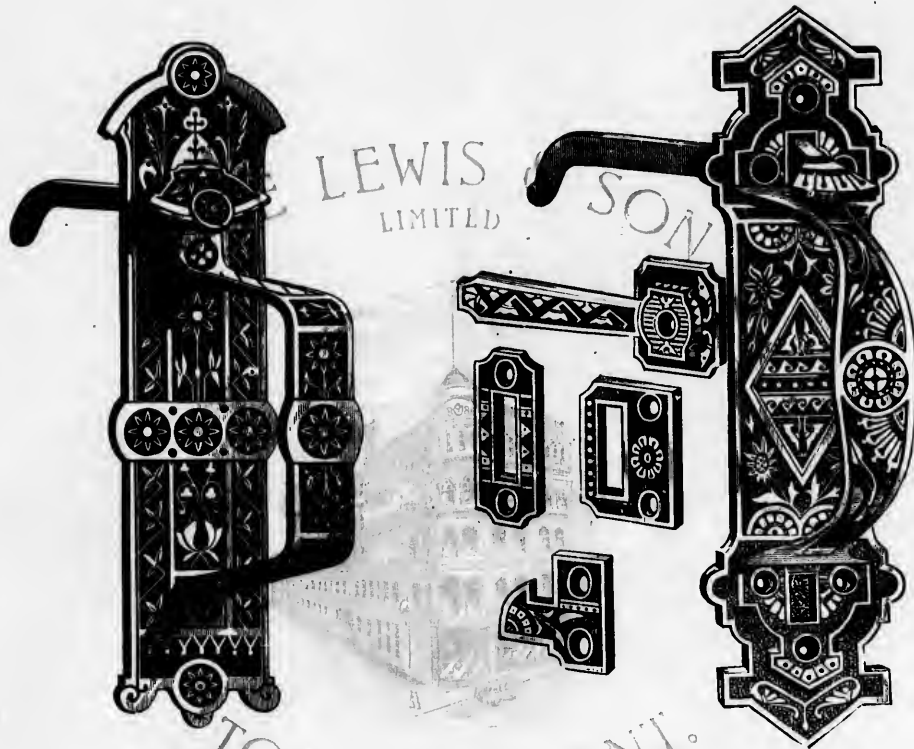

No. T37

No. 1887

TORONTO, ONT.
Half size cuts.

No. T37—Amber Bronzed, Oblique Handle, Right or Left Hand.....	per doz.	\$4.00
“ 1887— “ “ “ “	“	2.70

Half-dozen in a box.

\$24.00
10.00

SCREEN DOOR CATCHES

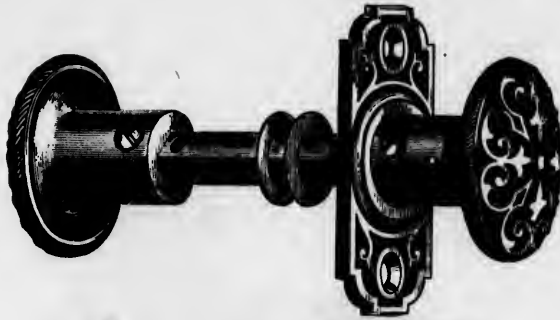

No. T6440—Amber Bronzed Latch with Stop, Reverse Bevel, Patent Triangular Bolt, Packed with Knobs and Screws, per doz..... \$3 20

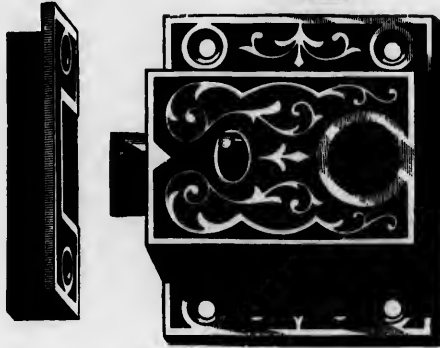

No. T6440

COTTAGE LATCHES

No. 87—Amber Bronzed..... per doz. \$1.60
 " 82— " " " " 1.70

No. 82 has Rounded Handle.

One dozen in a box, with Screws.



No. 87

WROUGHT IRON THUMB LATCHES

Complete with Furniture.

EXTRA HEAVY

Oblique Handle, Polished.

No. 4—Plate 10 x 2½ inch.....per doz. \$10.00
 " 5— " 10½ x 2½ " " 12.00



Nos. 4 and 5

RICE LEWIS & SON
 NORFOLK LATCHES LIMITED

Straight Handle, Square Plate, Japanned.

No. 6—Plate 9½ x 2½ inch.per doz. 8.00

JAPANNED THUMB LATCHES



WROUGHT LATCH. No. 3. Half size cut.

Nos.....	per doz.	\$0.70	0.80	0.90
Japanned Thumb Latches				

One dozen in a box.

STORE DOOR HANDLES

JAPANNED



No. 16. Half size cut.

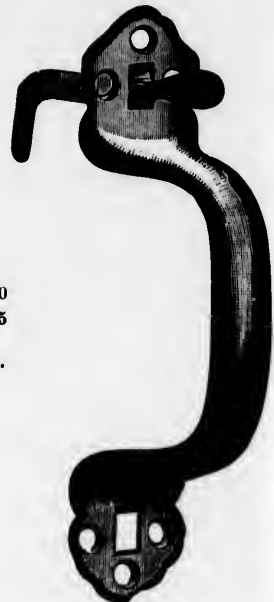

No. 6. Half size cut.

No. 16—With Plate.....per doz. \$1.80
 " 6—Without Plate..... " 1.45

Half-dozen in a box; each set papered separately.

JAPANNED BARN DOOR LATCHES

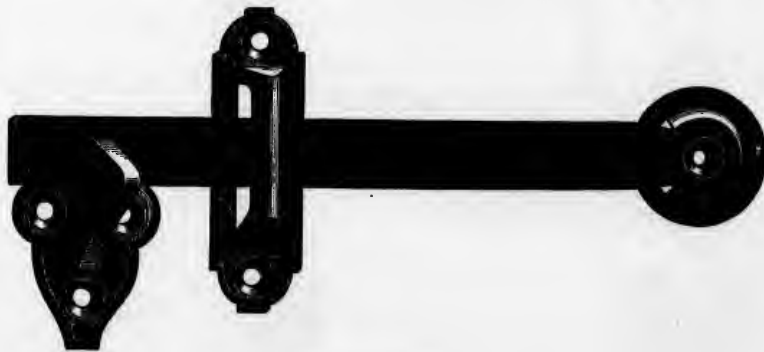

No. 5. Half size cut.

No. 5—Extra Heavy, with Wrought Latch.....per doz. \$2.00
 Half-dozen in a box.



No. 1



No. 1

BARN AND STABLE DOOR LATCHES

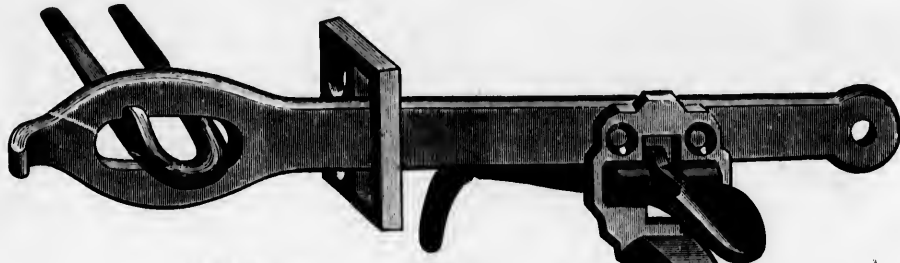

Half size cut

RICE LEWIS & SONS
LIMITED

No. 196—Japanned Barn Door Latch with Hasp . . . per doz. \$2.90

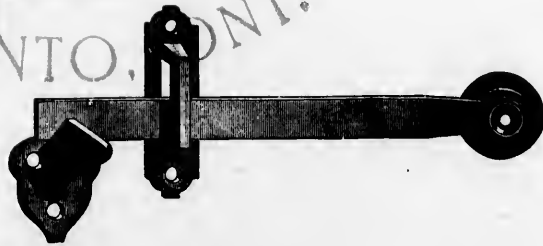

TORONTO, ONT.

No. 195, WROUGHT LATCH

No. 195—Japanned Stable Door Latch per doz. \$3.40

WROUGHT STEEL SQUARE BOLTS



Extra Heavy.

Size.....	6 x 5/8	8 x 3/4	10 x 1 1/4	inch.
No. 10—With Brass Knob.....	per doz. \$4.20	6.20	7.50	

WROUGHT STEEL FLAT TAIL BOLTS

Size.....	12	15	18	24	inch.
No. 1048—Plates 2 1/2 inches wide, Bolts 1 1/4 inch.....	per doz. \$12.00	13.25	14.25	16.00	

WROUGHT IRON TOWER BOLTS

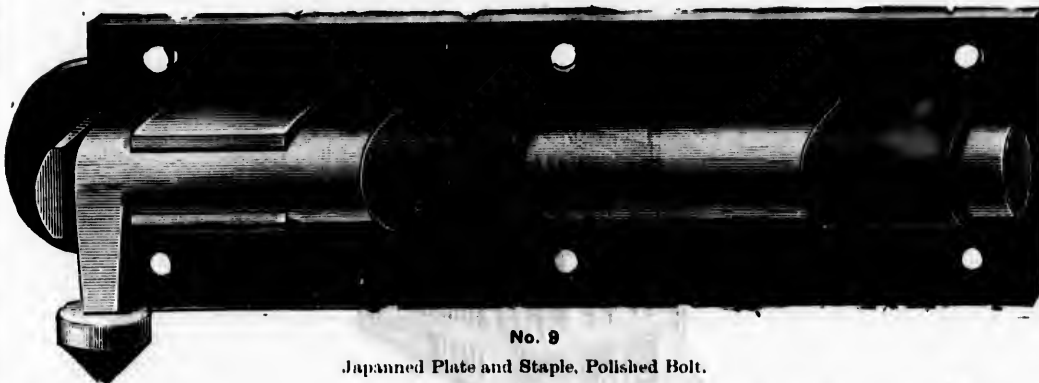

No. 9

Japanned Plate and Staple, Polished Bolt.

Size.....	3	4	5	6	7	8	inch.
No. 9.....	per doz. \$0.70	1.00	1.20	1.40	1.70	2.00	

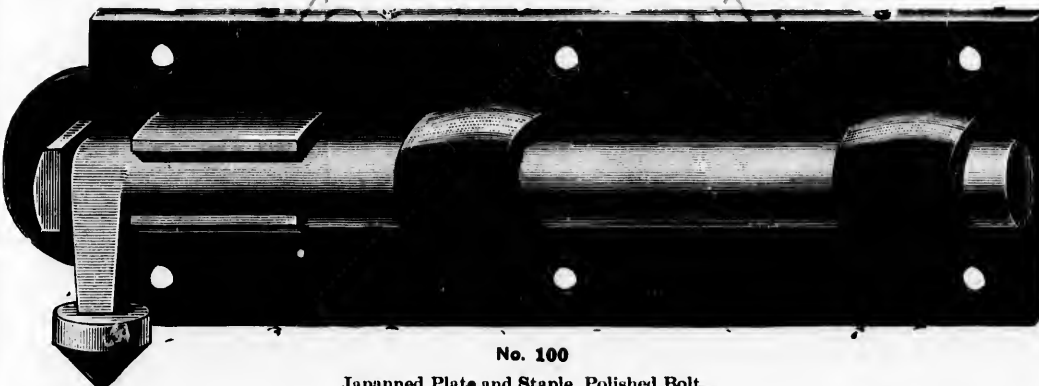

No. 100

Japanned Plate and Staple, Polished Bolt.

Size.....	3	4	5	6	7	8	10	inch.
No. 100.....	per doz. \$1.00	1.30	1.70	2.00	2.50	2.70	3.30	

GALVANIZED HASP BOLTS

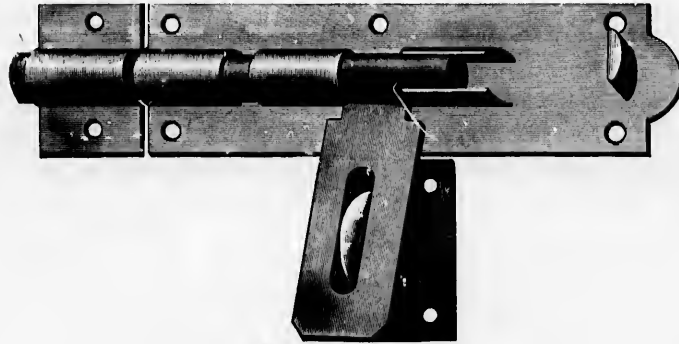

No. 8, 6 inch. Half size cut.

Size.....	6	8	10 inch.
No. 8—Galvanized Hasp Bolts.....	per doz. \$5.00	6.00	7.50

One dozen in a package.

SPRING BOLTS

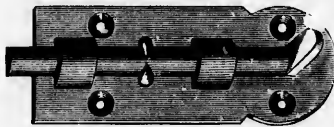

No. 2906K

NECK BOLTS



No. 325

Size.....	2	2½	3	3½	4 inch.
No. 2900K—Iron, Polished.....	per doz.	\$0.35	0.40	0.45
" 2901K—Brass, ".....	"	0.90	1.20	1.70
" 2906K— " Half Round Bolt.....	"	1.20	1.60	2.00	2.40
" 315 —Iron, Polished Square Bolt, Japanned Plate....	"	0.70	0.75	0.85	1.00
" 325 — " Neck Bolt, Polished, "	"	0.75	0.85
" 2902 — " " "	"	0.30	0.35	0.40
" 2903 —Brass, " "	"	1.00	1.40

BARREL BOLTS



Nos. 1077 and 1078

Size.....	2½	3	4	5	6 inch.
No. 1078 —Steel, Polished Bolt, Japanned Plate, Brass Knob... per doz.	\$1.10	1.25	1.45
" 382 —Cast, Wrought Bolt, Polished Brass Knob.....	"	0.90	1.00
" 1077 —All Brass, Polished.....	"	3.50	4.30	4.90
" 4018 —Brass Plate, with Steel Bolt and Brass Knob.....	"	3.50	3.75	4.70	5.70
" 1930B—Plain Bronze Metal, Heavy.....	"	10.20
" 2923 —Wrought Iron, Bronze-Plated.....	"	1.80

SPRING FOOT BOLTS

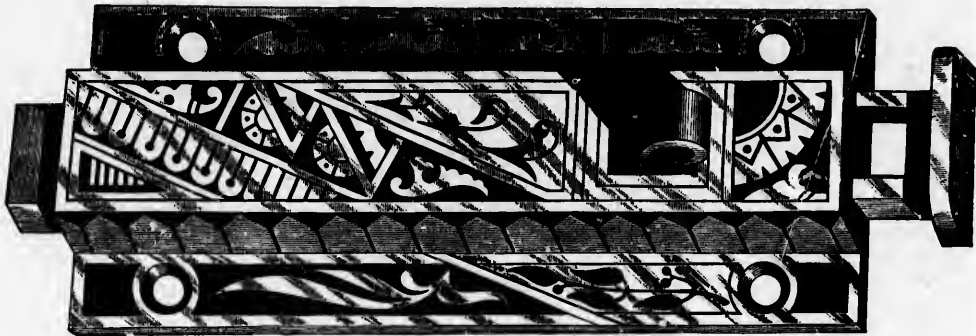

No. 3250

Size.....		6	8	inch.
No. 3250 —Iron, Amber Bronzed.....	per doz.	\$5.00		
“ P3250 — “ Persian Bronzed (14 Finish).....	“	6.00		
“ 2948 —Bronze Metal (3 Finish).....	“	12.00		
“ T1491A—Iron, Amber Bronzed.....	“	4.00	4.60	

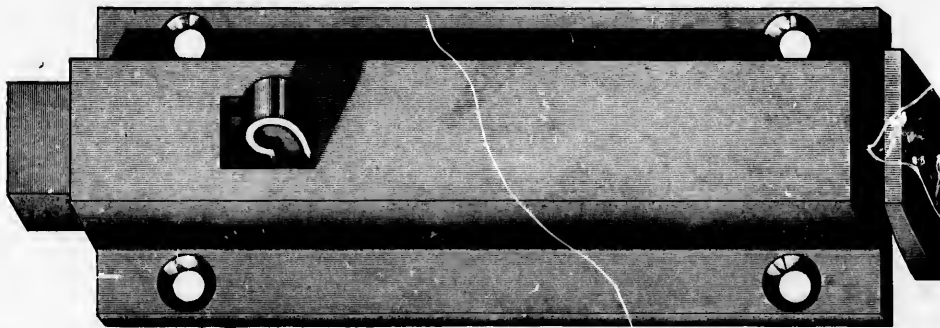

No. 4250 $\frac{1}{2}$

Size.....			6	inch.
No. 4250 $\frac{1}{2}$ —Bronze Metal, Polished (Corbin's).....	per doz.	\$19.50		
“ 948 — “ “ (Peterboro').....	“	13.00		

Half-dozen in a box.

Size...
No. T1
“ T1
“ P
“
“
“

Size...
No. 8
“ 8
“ 4

CHAIN BOLTS



4 inch. Full size cut.

Size.....		3	4	6	8	10 inch.
No. T1481A—Amber Bronzed.....	per doz.	\$2.40	2.80	4.00	4.80
" T1484A—" (Reverse Bevel).....	"	3.40	4.40
" P3252—Persian " (14 Finish).....	"	6.00
" 2936—Bronze Metal, (3 Finish).....	"	12.00
" 353—Japanned, Polished Bolt, (to match No. 501, page 500).....	"	2.70	3.20	4.00	5.00
" 384—" (Reverse Bevel).....	"	3.00	3.60	4.50	6.10

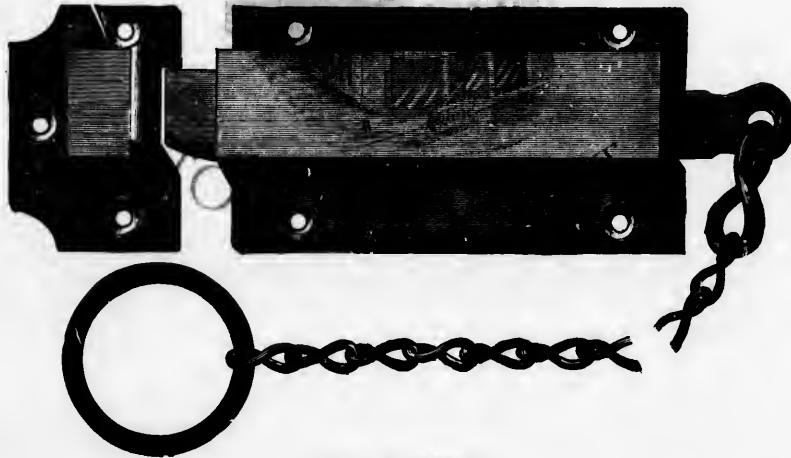

4 inch. Full size cut.

Size.....		4	6 inch.
No. 834—Bronze Metal (Peterboro').....	per doz.	\$9.00
" 836—".....	"	13.00
" 4252—" (Corbin's).....	"	17.50

Half-dozen in a box.

FLUSH BOLTS



No. 702, 8 inch.
Full size cut.

ORNAMENTAL

No. T88A

AMBER BRONZED

Size.....	6	8	10	12	18	24 inch.
Per doz...	\$2.00	2.40	2.60	2.90	4.20	5.30

No. 702

BRONZE-PLATED

(10 Finish.)

Size.....	6	8	12 inch.
Per doz.....	\$3.20	3.80	4.80

No. 705

BRONZE-PLATED

(10 Finish.)

With Bronze Metal Knob and Plate.

Size.....	6	8	12 inch.
Per doz.....	\$4.70	5.50	6.50

PLAIN

No. 708

IRON, BRONZE-PLATED

Size.....	6	8	12 inch.
Per doz.....	\$4.50	5.00	6.00

No. 707

BRONZE METAL

Size.....	6	8	12 inch.
Per doz.....	\$8.00	9.50	12.50

Half-dozen in a box.

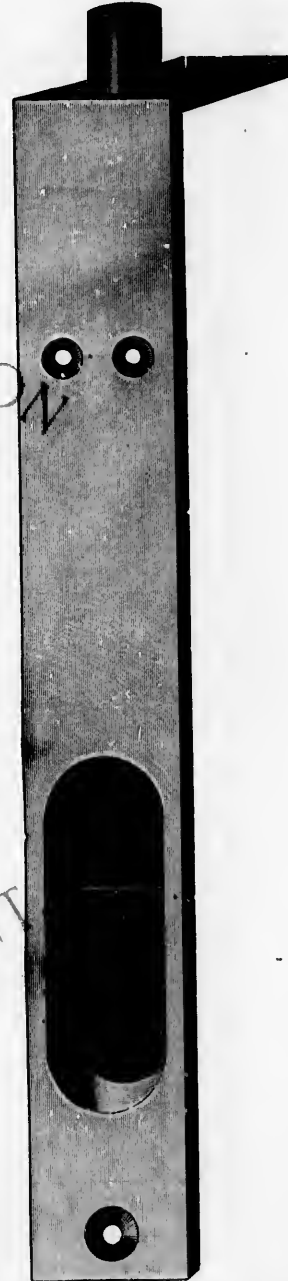

Nos. 707 and 708, 8 inch.
Full size cut.

z. \$4.90

z. 2.50
3.40

0.95
1.15
1.30
2.70
3.75

MORTISE FLUSH BOLTS



No. 2852

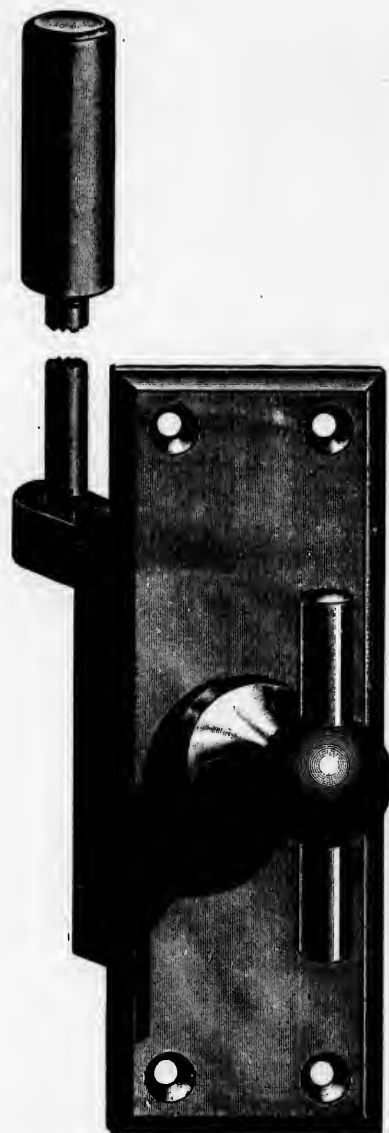

No. 02858

No. 2852—Bronze Metal, with Knob, from 8 to 30 inches.....each \$1.55
 " 02858 - " " " T Handle from 12 to 30 inches..... " 4.50

One-sixth dozen in a box.

No. 3
 " 1
 " P326
 " 263
 " 264

No. 0472
 " 2650

CHAIN DOOR FASTENINGS

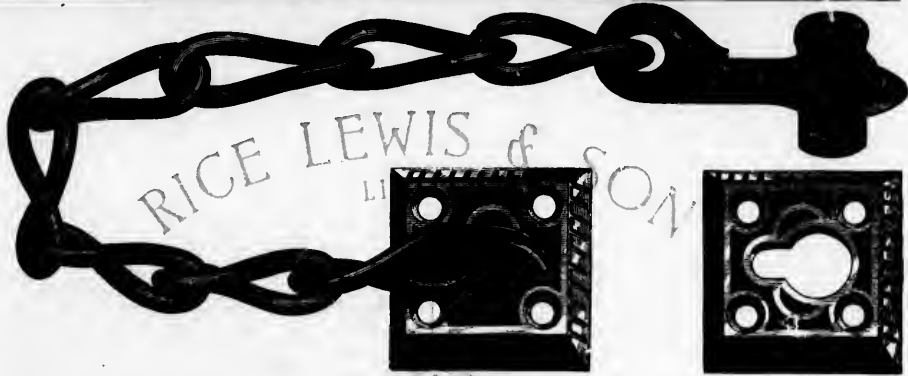
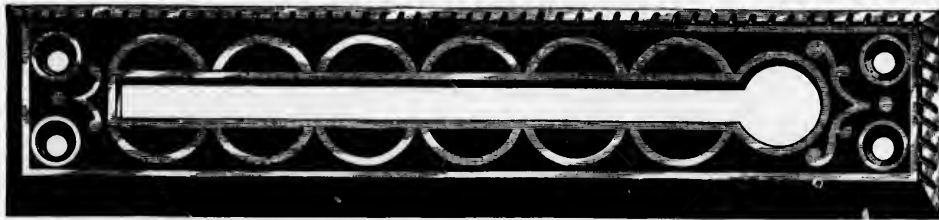

No. P3264

No.	36-6 inch, Japanned, Steel Chain	per doz.	\$3.50
"	16-6 " Amber Bronzed, Bronzed Chain	"	4.00
"	P3264-6 " Persian Bronzed (14 Finish), Bronzed Chain	"	6.50
"	2637-4 1/2 x 1 1/2 inch, Ornamental Cast Brass Plate, 3 1/2 inch Brass Chain	"	9.75
"	2642-3 1/2 x 1 1/2 " Plain " 3 1/2 "	"	7.50



No. 0472

No.	0472-6 inch, Plain Bronze Metal	per doz.	20.00
"	2650-5 x 1 inch Wrought Brass, 4 inch Wrought Brass Chain	"	5.25

each \$1.55
" 4.50

DOOR PULLS



No. 2396



No. 3732. Full size cut.

LEWIS & SON
LIMITED

- No. 2396 — 11½ x 2¼ inch, Bronze Metal, Ornamental, Fluted Design for Right and Left Hand Doors.....each \$3.60
- No. 2396½ — Same as 2396, only Plain, Fluted Designeach 3.60
- No. 2309 — 9 x 2½ inch, Bronze Metal, Plain Design, Square Cornerseach 1.80
- No. 3732 — Amber Bronzed.....per doz. 1.40

ONTARIO, ONT.

\$ 7.20
12.00
7.20
12.00

3½ inch.

.....
2.15
2.50
.....
.....
.....

z. \$2.40

DOOR PULLS



No. 100—Japanned Wire Door Pulls for Screen Doorsper gross \$2.00
 " 200—Brass-Plated " " " " " 2.20



No. 601

No. 601—Wrought Brass, Polishedper doz. 1.00



No. 13654

Cast Brass, Polished and Lacquered.

Size	5	5½	6 inch.	
No. 13654	per doz. \$1.60	1.90	2.10	



Nos. 02207 and 1736

No. 02207—Iron, Japanned			per doz. 1.20	
" 1736—Bronze Metal, Highly Polished.....			" 6.50	

No. 10
 " 16
 " 16

No. 730

No. 2208
 " 3208

DOOR PULLS



- | | | |
|--|----------|--------|
| No. 1692 $\frac{1}{2}$ -3 $\frac{1}{4}$ inch, Bronze Metal, Polished | per doz. | \$2.70 |
| " 1694 $\frac{1}{2}$ -4 $\frac{1}{4}$ " " " " | " | 3.00 |
| " 1696 $\frac{1}{2}$ -6 " " " " | " | 6.30 |

RICE LEWIS & SON
LIMITED



No. 730

- | | | |
|--------------------------------------|----------|--------|
| No. 730—Bronze Metal, Polished | per doz. | \$5.00 |
|--------------------------------------|----------|--------|



Nos. 2208 and 3208

- | | | |
|---|----------|------|
| No. 2208—Bronze Metal, Ornamental | per doz. | 5.70 |
| " 3208—Iron, Amber Bronzed | " | 0.70 |

FINGER AND PUSH PLATES



No. 2325 $\frac{1}{2}$



No. 9354. Full size cut.



No. 9354 $\frac{1}{2}$. Full size cut.

No. 9354	—Bronze Metal.....	per doz.	\$10.00
" 9354 $\frac{1}{2}$	— " "	"	16.00
" 3971	—Amber Bronzed, 7 $\frac{1}{4}$ x 2 $\frac{1}{4}$ inch.....	"	3.00

No. 2325 $\frac{1}{2}$ —Plain Bronze Metal (Beveled)

Size.....	10 x 3 $\frac{1}{2}$	12 x 3	15 x 3 $\frac{1}{2}$ inch.
Per doz.....	\$12.60	13.50	26.00

PORCELAIN FINGER PLATES

Size.....	7 $\frac{3}{4}$ x 3 $\frac{1}{8}$	11 $\frac{1}{4}$ x 2	11 $\frac{1}{4}$ x 2 $\frac{1}{2}$ inch.
No. 330—Plain.....	per single doz.	\$2.50	2.50
" 345— "	"	2.50
" 117—With Gilt Stripe.....	"	5.50

No. 25
" 48

No. P34

No. 2330 $\frac{1}{2}$

LETTER BOX PLATES

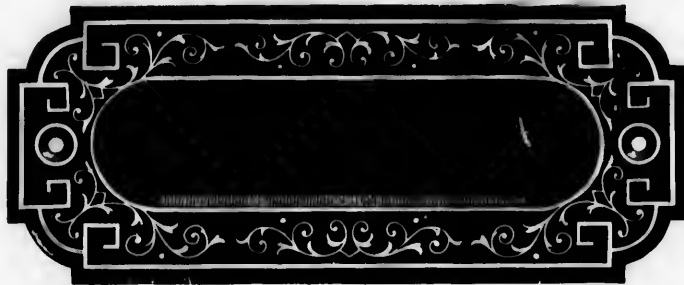

No. 25

No. 25—2½ x 5½ inch, Amber-Bronzed, with Face Screws per doz. \$2.60
 " 46—2½ x 7½ " " " Back " " " " 5.00

RICE LEWIS & SON
 LIMITED



No. P3426½

No. P3426½—2 x 6½ inch, Persian-Bronzed (14 Finish), with Back Screws per doz. 5.30



No. 2339½

No. 2339½—2½ x 5½ inch, Bronze Metal, with Face Screws per doz. 15.80

Half-dozen in a box.

\$16.00
 16.00
 3.00

½ inch.

½ inch.

LETTER BOX PLATES

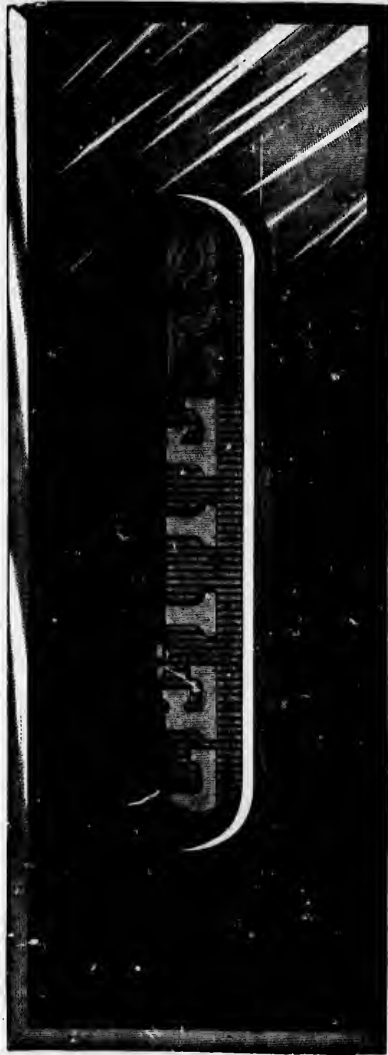

No. 2306 $\frac{1}{2}$

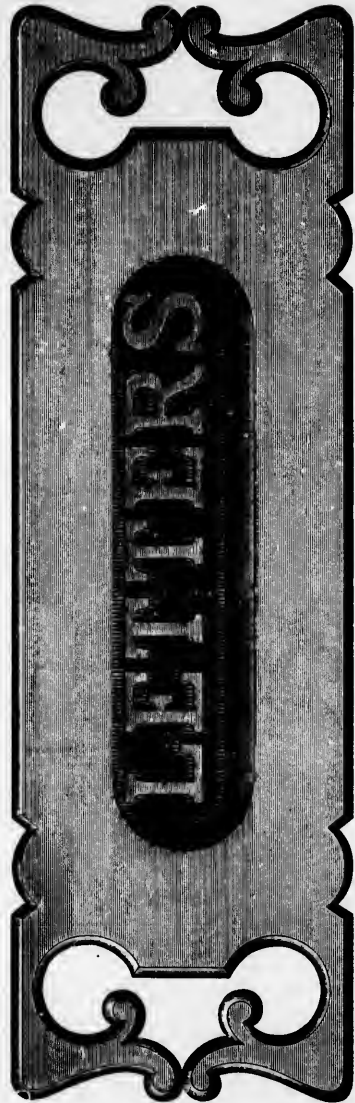

No. 02306 $\frac{1}{2}$

No. 2306 $\frac{1}{2}$ —2 $\frac{1}{4}$ × 6 $\frac{1}{4}$ inch, Bronze Metal with Back Screws	per doz.	\$14.40
" 02306 $\frac{1}{2}$ —2 $\frac{1}{4}$ × 8 $\frac{1}{4}$ " " " Plate and Screws	"	23.00
" 02306 $\frac{1}{2}$ —3 $\frac{1}{4}$ × 8 " as No. 2306 $\frac{1}{2}$, Bronze Metal with Back Plate and Face Screws	"	36.00

No. 02306 $\frac{1}{2}$ suitable for newspapers.

Half-dozen in a box.

4 inch

1 $\frac{1}{2}$ inch
2 "

No. 13

ROTARY DOOR BELLS AND PLATES

NEW DEPARTURE

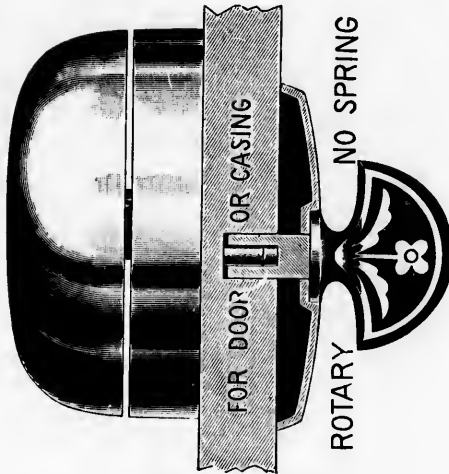

NICKEL-PLATED BELL

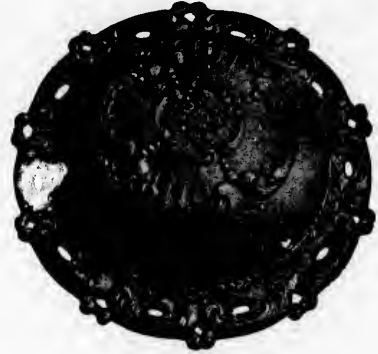

No. 023, BELL



"A" PLATE

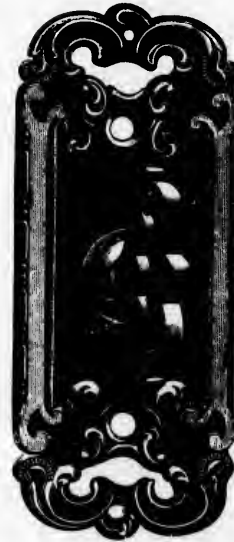

"SH" PLATE

Turn Plates, Cast Bronze Metal, complete with Screws.

No. 191—"A" Plate, complete, with 3 inch Nickel-Plated Bell.....	per doz.	\$15.50
" 100— " " " 3 1/4 " " "	"	18.00
" 991—"SH" Plate " " 3 " " "	"	15.50
" 901— " " " 3 1/4 " " "	"	18.00

No. 109
" 100

No. 891-
" 801-
" 023-

LEVER DOOR BELLS



Nos. 719 and 720

ORNAMENTAL

No. 719—4 inch, Lever Door Bells, Amber Bronzed	per doz.	\$8.00
" 720—4 " " " Bronze-Plated (10 Finish)	"	8 50
" 723—4 " " " Bell Metal (3 Finish)	"	11.00
" 724—5 " " " Amber Bronzed	"	8.00
" 725—5 " " " Bronze-Plated (10 Finish)	"	10.50
" 728—5 " " " Bell Metal (3 Finish)	"	13.00

PLAIN

No. 21—4 inch, Lever Door Bells, Bell Metal	per doz.	11.00
" 22—4 " " " " Nickel-Plated	"	12.00
" 26—5 " " " " "	"	13 00
" 27—5 " " " " Nickel-Plated	"	14.00

No. 41
 " 41
 " 232
 " 332
 " 432

BELL LEVERS

Full size cuts.

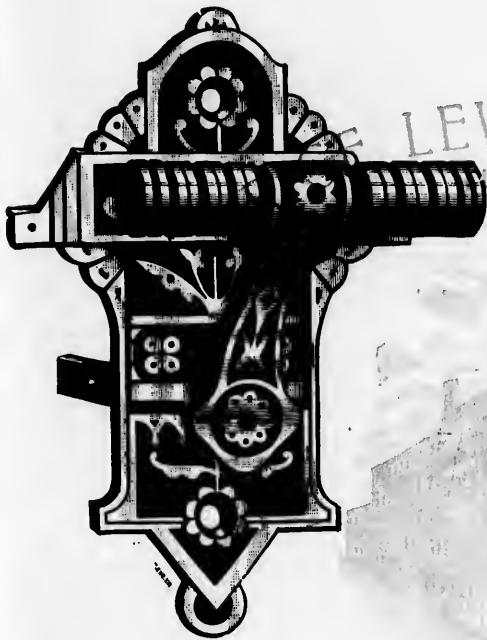

LEWIS & CO. LIMITED



Nos. 410 and 411

Nos. 4325 to 4325

TORONTO, ONT.

No. 410—Amber Bronzed	per doz.	\$2.00
“ 411—Bronze-Plated (10 Finish)	“	3.00
“ 4325—Bronze Metal	“	7.00
“ 4325—Amber Bronzed	“	3.50
“ 4325—Bronze-Plated (10 Finish)	“	5.00

Half-dozen in a box.

\$6.00
8 50
11.00
8.00
10.50
13.00

11.00
12.00
13 00
14.00

BELL LEVERS AND PULLS

Full size cuts.

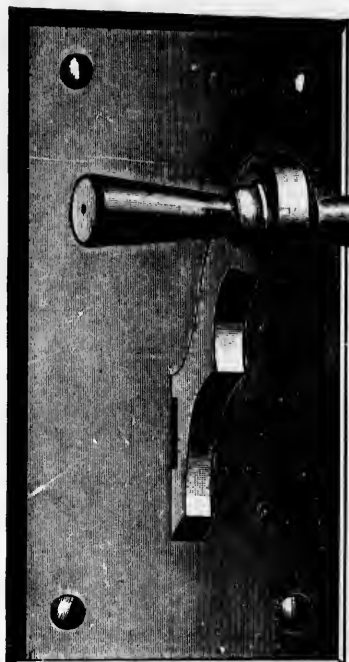

No. 428

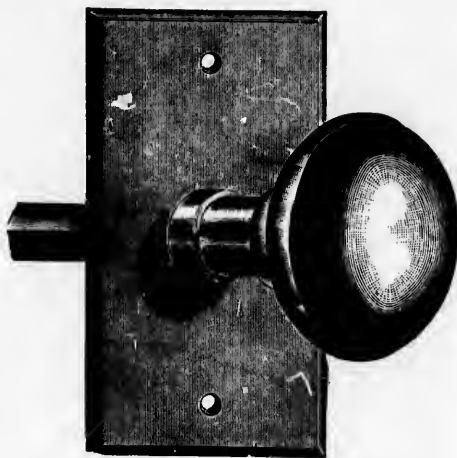

No. 1548

No. 428—Plain, Bronze Metal, Polished	per doz.	\$10.00
" 1548— " " " " "	"	6.00

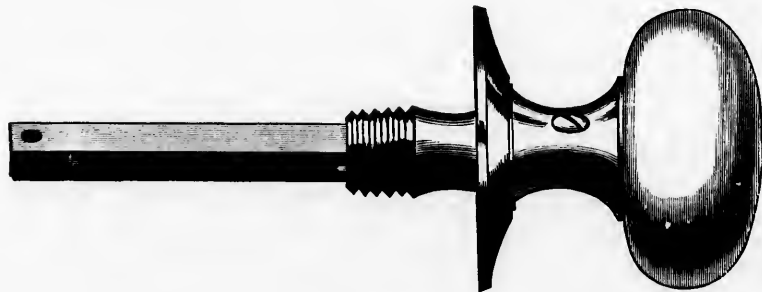

No. 07

No. 07—Porcelain Knob, Plated Mountings	per doz.	5.00
---	----------	------

No. 118
 " 118
 " 54
 " 118

ELECTRIC PUSH BUTTONS



No. 1190

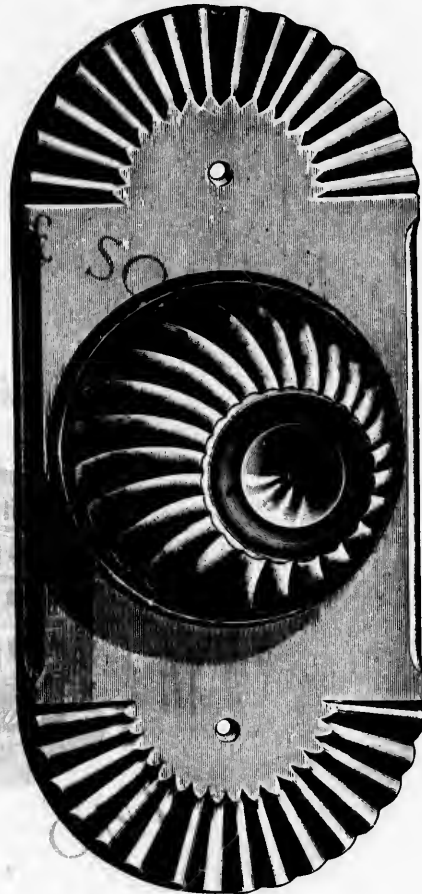

No. 1189½



No. 540½

LEWIS
LIMITED

TO.

No. 1190	—Bronze Metal, full size cuts.....	per doz.	\$ 9.00
" 1189½	— " " " "	"	43.20
" 540½	— " " " "	"	10.80
" 1188½	— " 2¼ inch, Round (same Top as No. 1190).....	"	4.00

Designs to match Front Door Sets, to order.

\$10.00
6.00

5.00

HOUSE BELLS ON CARRIAGES

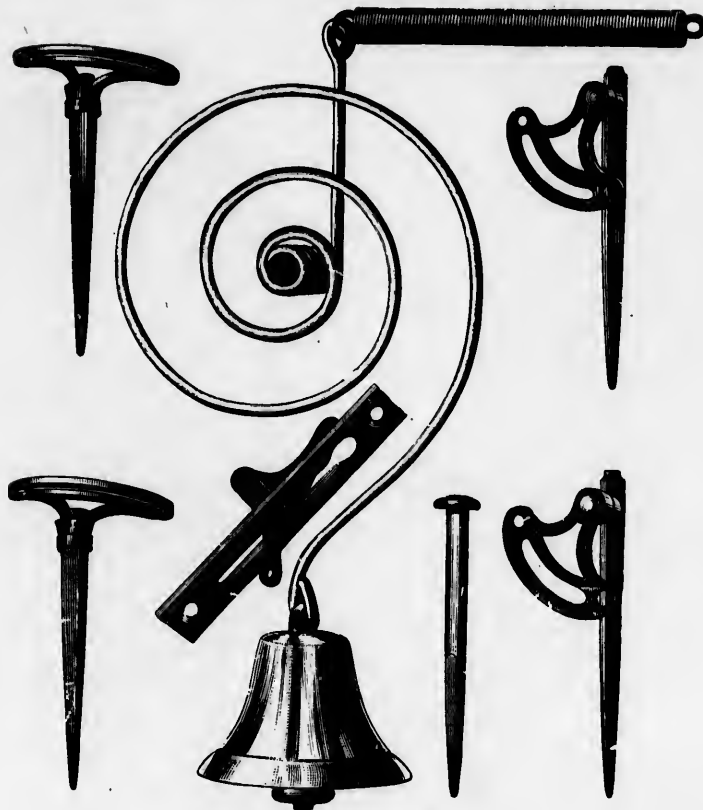

No. 123, complete. Half size cut.

No. 123—With No. 3 Polished Bells, complete with Trimmings, as per cut per doz. **Y \$9.50**
 Half-dozen in a package.

ALARM DOOR GONGS



No. 125

No. 125—4 inch, Bronzed Steel Bells, with Alarm Attachment per doz. 5.00

Size.
No. 1

Diamete
Finish
Nickel

Diamete
No. 1

No. 21
" 5

HOUSE GONG BELLS

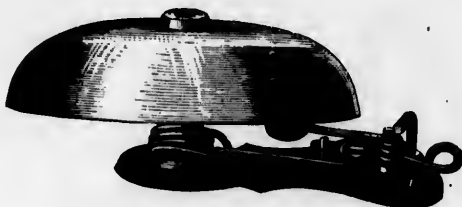

Half size cut of 5 inch.

No. 120, BRONZED STEEL

Size.....	3	4	5	6	inch.			
No. 120	per doz.				\$4.00	5.00	7.00	10.00

One-twelfth dozen in a box.

RICE LEWIS & SON
LIMITED

ENGINEERS' GONG BELLS

No. 10

With Brass Gong, Iron Frame.

Diameter.....	3	4	5	6	8	10	12	14	15	16	18	in.
Finished.....	each	\$2.25	2.75	3.25	3.90	6.75	9.00	13.00	23.00	27.00	30.00	38.00
Nickel-Plated....	"	2.40	2.90	3.45	4.15	7.25	9.60	16.00	24.25	28.25	32.00	40.00



No. 10

No. 11

With Rolled Steel Gong, Iron Frame, same style as No. 10.

Diameter.....	5	6	7	8	9	10	12	14	16	inch.
No. 11—Nickel Finish.....	each	\$1.25	1.90	2.50	3.75	5.00	6.25	10.00	15.00	20.00

ROLLED STEEL GONGS

No. 15

With Foot Strike for Street Cars and Fire Reels, etc.

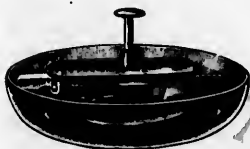

No. 15

13 inch Gong, Nickel Finish.....	each	20.00
14 " " " "	"	22.50

SLIDE BELL PULLS



No. 219. Full size cut.

No. 219—6½ inch Long, ¾ inch Wide, Wrought Brass.....	per doz.	5.90
" 50—3½ " " 1½ " " Cast Brass, Heavy.....	"	10.00

Y \$9.50

5.00

STEEL ALLOY CHURCH AND SCHOOL BELLS



Nos.....	20	22	24	26	28	30	32	34	36	40	44	48	54
Weight of Bell only.....	110	122	153	220	294	336	388	487	605	750	1060	1380	2050 lbs.
Weight of Bell and Mountings..	160	175	225	325	450	550	600	750	875	1200	1600	2050	3000 "
Price complete.....	\$18.00	20.00	25.00	40.00	50.00	65.00	75.00	90.00	110.00	150.00	200.00	250.00	375.00

Bells are numbered by the diameter in inches. The weights and prices above are for complete Bells and include Wood Sills, Wheel for Rope, and for numbers 30 to 54, Tolling Hammers without extra charge; Tolling Hammers for numbers 24, 26, 28, when so ordered, \$5.00 each extra, but are not recommended.



FACTORY AND FARM BELLS

Complete with Hangings.

No.	Diameter.	Approximate Weight.	Price.
No. 1	15 inches.	40 lbs.	\$2.40
" 2.....	17 "	60 "	3.60
" 3.....	19 "	75 "	4.50
" 4.....	21 "	100 "	6.00

MENEELY'S WARRANTED PURE BELL-METAL BELLS

For Churches, School-Houses, Factories, Fire-Halls,
Steamboats, etc.

Prices on application.

No. 1—C
" 2—

Size Nos.
Height v
Length v
Width
Per doze

Size Nos.
Height v
Per doze

No. 1—E

SHEEP AND COW BELLS



No. 2. Full size cut.

No. 1—Cast Sheep Bells per doz. \$3.00
 " 2— " " 3.80

RICE LEWIS & SON
LIMITED

COW BELLS



HOLSTEIN COW BELLS

Size Nos.	0	1	2	3	4	5	6	7	
Height without Loop.....	7	6½	5½	5	4½	3½	2½	2½	inch.
Length of Mouth.....	6	5½	5	4½	3½	3½	2½	2½	"
Width ".....	3½	3½	3½	2½	2½	2½	2½	1½	"
Per dozen.....	\$12.00	10.00	8.00	6.00	5.00	4.00	3.00	2.50	

WESTERN COW BELLS

Size Nos.	2	3	4	5	6	9
Height without Loop.....	6	5½	5½	5½	4½	2½
Per dozen.....	\$10.00	9.00	8.00	6.50	5.50	2.50

COW BELL STRAPS

No. 1—Black Leather, 1½ × 48 inches per doz. \$4.15

50 lbs.
 " "
 " "
 " "
 " "
 " "
 " "
 " "
 " "
 " "

Price.
 \$2.40
 3.60
 4.50
 6.00

ls and
 Tolling

GLOBE HAND BELLS

CONE'S PATENT



SILVER WHITE FINISH

Nos	40	50	55	60
Size	4	5	5½	6 inch.
Per dozen	\$22.25	26.65	37.50	50.00

One-sixth dozen in a box.

HAND BELLS

PURE BELL-METAL, POLISHED

Nos	4	6	8	10	12	14
Diam. of Mouth	3	3½	4½	5½	6	6½ inch.
Per dozen	\$3.00	6.40	10.20	18.00	21.60	26.40

NICKEL-PLATED

Nos	2	4	6	8	10
Diameter of Mouth	2½	3	3½	4½	5½ inch.
Per dozen	\$2.60	4.80	8.10	12.00	21.50



No. 8. Half size cut

WHITE METAL TEA BELLS

NICKEL-PLATED

No.	21	—Diameter of Mouth 2½ inch, Rose-wood Handles.....per doz.	\$3.50
"	22	—Diameter of Mouth 2¾ inch, Rose-wood Handles.....per doz.	3.00
"	6818-1	—Diameter of Mouth 2 inch, Ebonized Wood Handles...per doz.	2.00
"	6818-2	—Diameter of Mouth 2½ inch, Ebonized Wood Handles...per doz.	3.20
"	6818-3	—Diameter of Mouth 3¼ inch, Ebonized Wood Handles...per doz.	3.60



Nos. 21 and 22



No. 6818

No.
No. 18
" 18
" 18
" 18
" 80

No. 12
" 32
" 22
" 42

No. 57-
" 58-3
" 59-2
In t
quickly d

TABLE BELLS



No. 1872



No. 1858



No. 1823

No. 1872-7—2½ inch, Nickel-Plated Steel Dome and Stand, to Push.....	per doz.	\$ 5.00
“ 1872-8—3¼ “ “ “ “ “ “ “ “ “ “	“	6.00
“ 1858-8—3¼ “ “ “ “ “ “ “ “ “ “	“	5.00
“ 1823—2½ “ “ “ “ “ “ “ “ “ “	“	10.50
“ 8091—2½ “ “ “ “ “ “ “ “ “ “	“	7.50

NEW DEPARTURE CALL BELLS



Nos. 12 and 22



Nos. 32 and 42

No. 12—2½ inch Gong, Nickel-Plated Gong and Figured Base	per doz.	20.00
“ 32—2½ “ “ “ “ “ “ “ “ “ “	“	20.00
“ 22—3½ “ “ “ “ “ “ “ “ “ “	“	28.00
“ 42—3½ “ “ “ “ “ “ “ “ “ “	“	28.00



No. 57



No. 58

No. 57—3 inch, Silver-Plated Gong and Base.....	per doz.	54.00
“ 58—3 “ “ “ “ “ “ “ “ “ “	“	54.00
“ 59—2½ “ “ “ “ “ “ “ “ “ “	“	54.00

In the New Departure Call Bells electrical results are obtained without the aid of a Battery. The winding is quickly done by simply turning the gong. Fully 250 rings for each winding.

60
6 inch.
0.00

14
0¼ inch.
20.40

10
5½ inch.
21.50

318

TABLE GONGS

POLISHED BRASS OR ANTIQUE FINISH

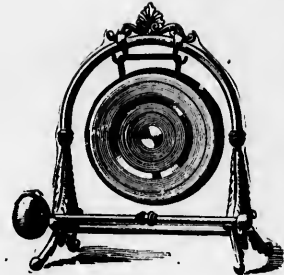
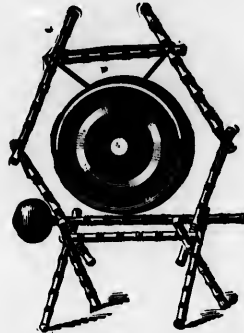

No. 50—4½ inch Gong.....each \$3.00 | No. 52—4½ inch Gong....each \$3.40 | No. 54—4½ inch Gong.....each \$4.50

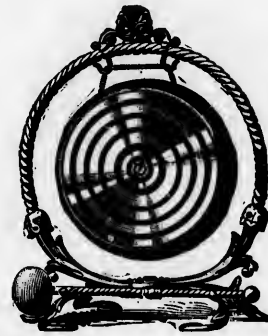
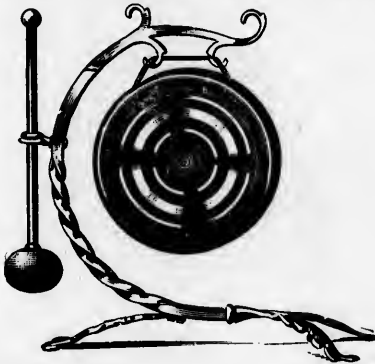

No. 60—6 inch Gong.....each \$5.25 | No. 63—6 inch Gong.....each \$5.65

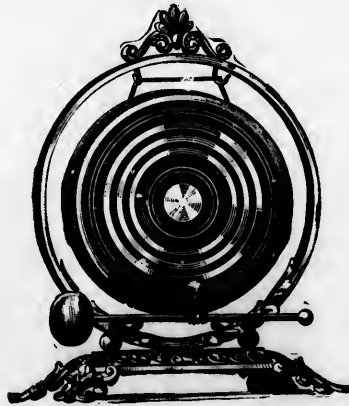

No. 70—8 inch Gong.....each \$10.50 | No. 75—8 inch Gong.....each \$7.50

Size.
No. 2
" 2

No. 2

Size...
No. 22

Size...
No. 235
" 235

AWNING SLIDES

MALLEABLE IRON, GALVANIZED

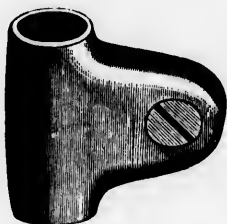

No. 221



No. 222

Size.....			$\frac{3}{8}$	$\frac{1}{2}$	$\frac{5}{8}$	$\frac{3}{4}$ inch.
No. 221.....	per doz.	\$0.65	0.80	1.25	1.55	
" 222.....		1.25	1.55	

RICE LEWIS & SON
LIMITED

AWNING HINGE



No. 228

No. 228—Awning Hinges, Malleable Iron, Galvanized.....per doz. \$0.50

AWNING SLIDE RODS



No. 227

Size.....			$\frac{3}{8}$	$\frac{1}{2}$	$\frac{5}{8}$ inch.
No. 227—Galvanized.....	per lb.	\$0.24	0.22	0.20	

Measure in the clear.

TORONTO, CAN.

AWNING HOOKS



No. 235

Size.....		1	1 $\frac{1}{4}$	1 $\frac{1}{2}$	2	2 $\frac{1}{2}$	3	3 $\frac{1}{2}$ inch.
No. 235 —Plain.....	per gross	\$0.50	0.60	0.70	0.80	1.00	1.00	2.00
" 235G—Galvanized.....	"	0.60	0.70	0.80	1.00	1.30	2.00	2.50

PERFECTION WINDOW STOP ADJUSTERS

TAPLIN'S

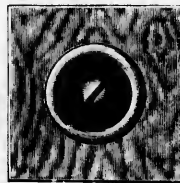

	Per gross
No. 1—Bronze Metal.....	\$6.40
“ 22—Oxidized Copper....	6.40
“ 31—Steel, Blued	4.80

Packed with Round Head Screws.

One dozen in a box; 12 boxes in a carton.

DIRECTIONS.—Bore a $\frac{1}{2}$ inch hole through the Bead or Stop, drive in the Adjuster, keeping the Slot as per illustration, press the Slot or Bead tightly against the Window Sash and put the Screw exactly in the Centre of Slot.

WEATHER STRIP

WOOD AND FELT



No. 0—For Sides, Tops and Bottoms of Windows,
Priceper ft. \$0.04

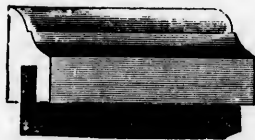

No. 1—For Sides and Tops of Doors and Large
Windows.....per ft. 0.05

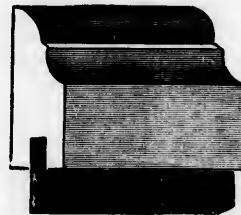

No. 2—For Bottoms of Doors.....per ft. \$0.00

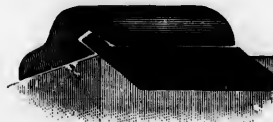

No. 4—For Joints between Sashes and for Centre
of Double Doors.....per ft. 0.07

Nos. 0 and 1 in 500 feet, and Nos. 2 and 4 in 200 feet bundles.

SASH LOCKS AND SUPPORTS

COOKE'S

Locks Sash at any point.

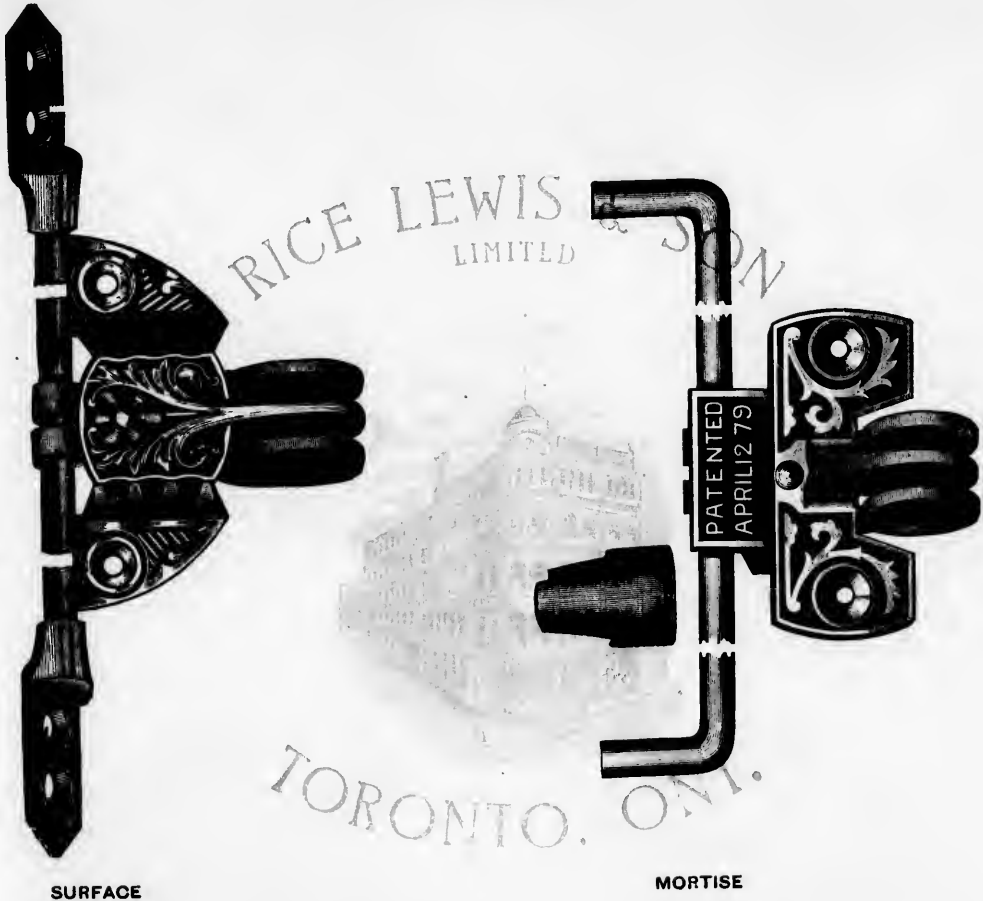

SURFACE

MORTISE

No. 1—Amber Bronzed, "Surface," for Lower Sash only.....	per doz.	\$3.00
2— " " "Mortise," for Upper or Lower Sash	"	3.00

Can be supplied in Bronze Metal or Oxidized Copper to order.

SASH FASTENERS

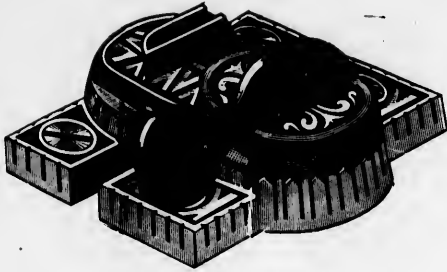

Nos. 2900 to 4900

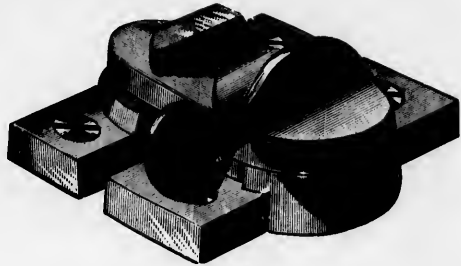

No. 1900

No. 2900—Bronze Metal (3 Finish).....	per doz.	\$5.00
" 3900—Amber Bronzed.....	"	1.00
" 4900—Bronze-Plated (10 Finish).....	"	2.50
" 1900—Plain, Bronze Metal, Polished.....	"	5.00

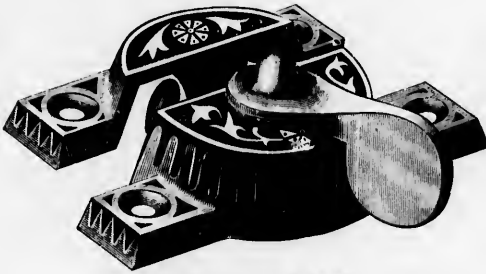

Nos. 03827 and P03827

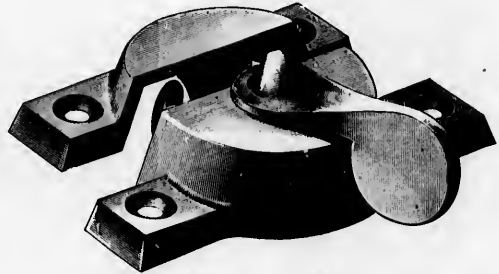

Nos. 1827 1/2 and N01827

No. 03827 — Iron, Amber Bronzed.....	per doz.	0.90
" P03827 — " Persian Bronzed (14 Finish).....	"	2.10
" N01827 — " Plain, Bronze-Plated.....	"	2.30
" 1827 1/2—Bronze Metal, Plain, Polished.....	"	4.10

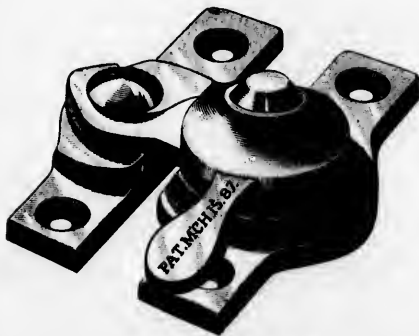

Nos. 1428 and N1428

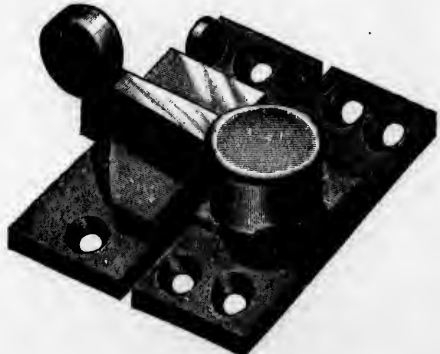

No. 4350

No. 1428—Wrought Steel, Amber Bronzed.....	per doz.	1.35
" N1428— " " Plain, Bronze-Plated.....	"	2.10
" 4350—Bronze Metal, Self Locking.....	"	6.50

One dozen in a box.

SASH FASTENERS

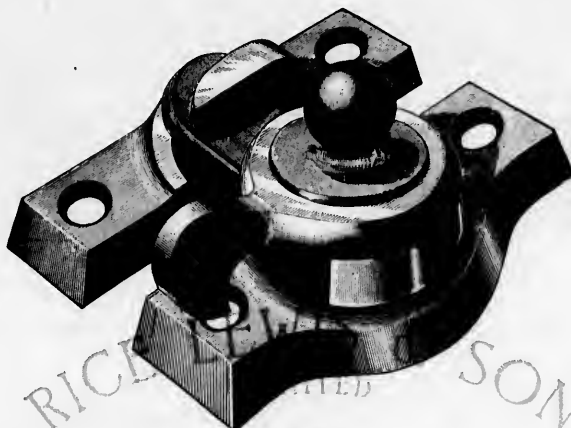

No. 1527 1/2

No. 1527 1/2—Bronze Metal, Extra Heavy (for Large Windows).....per doz. \$11.70
One dozen in a box.

WINDOW SPRING BOLTS



Nos. 10 and 20. Full size cut.

No. 10—Japanned.per gross 2.20
" 20—Japanned, Silver Tipped..... " 2.90
One-half gross in a box.

SASH OR WINDOW LOCKS

GARRETSON'S

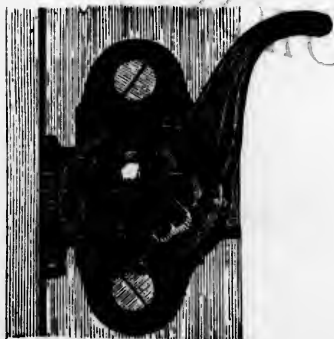

DIXON'S

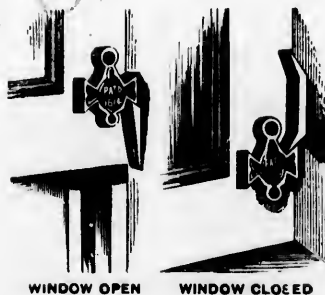

WINDOW OPEN

WINDOW CLOSED

Garretson's, Coppered Iron.....per gross 6.00
Dixon's, Coppered Iron..... " 8.00

Half gross in a box.

\$5.00
1.00
2.50
5.00

0.90
2.10
2.30
4.10

1.35
2.10
6.50

SASH LIFTS



No. T3940

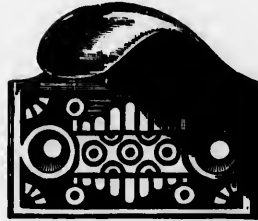

Nos. T443A and 4941

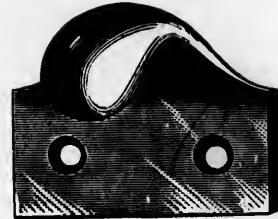

Nos. 2180, 2180 $\frac{1}{2}$, 2184

No. T3940—Amber Bronzed	per gross	\$3.00
“ T443A— “ “	“	3.00
“ T441 — “ “	“	3.70
“ 4941 —Bronze-Plated (10 Finish).....	“	0.72
“ 2180—Bronze Metal, Light.....	“	8.40
“ 2180 — “ “ Medium	“	15.00
“ 2184 — “ “ Heavy.....	“	31.25

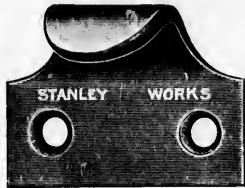

No. 483

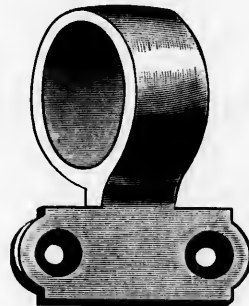

No. 1943

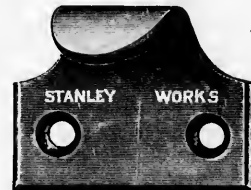

No. 485

No. 483—Steel, Bronzed, Planished, Square Edge	per gross	3.00
“ 485— “ “ Polished, Beveled Edge	“	7.85
“ 487D2— “ Planished, Old Copper Finish	“	4.00
“ 1943—Bronze Metal, Ring Sash Lift	“	10.00



No. 3951



Nos. 951 and 4951P

No. 3951—Amber Bronzed	per doz.	0.50
“ 4951P—Plain Iron, Bronze-Plated.....	“	0.80
“ 951— “ Bronze Metal, Polished	“	1.20

SASH LIFTS

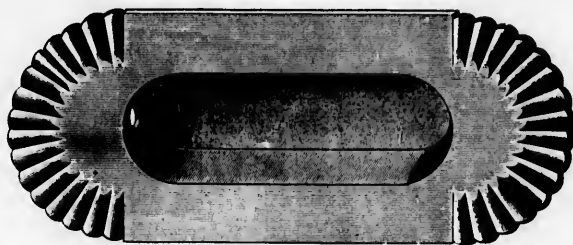

No. 2226 $\frac{1}{2}$

No. 2226 $\frac{1}{2}$ —4 x 1 $\frac{1}{2}$ inch, Bronze Metal, Fluted.....per doz. \$5.40



No. 3196



No. 2224

No. 3196—3 x 1 $\frac{1}{2}$ inch, Iron, Amber Bronzed.....per doz. 0.70
 " P3196—3 x 1 $\frac{1}{2}$ " " Persian " (14 Finish)..... " 1.10
 " 2224—3 $\frac{1}{2}$ x 2 inch, Cast Bronze Metal..... " 4.50
 " 2215—3 $\frac{1}{8}$ x 1 $\frac{1}{8}$ " Wrought Bronze Metal, recess similar to 3196..... " 1.15

SASH LIFTS AND LOCKS COMBINED



No. 3313

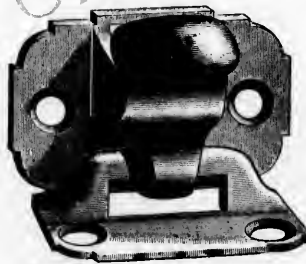

No. 4313 $\frac{1}{2}$

No. 3313—Iron, Amber Bronzed.....per doz. 1.10
 " 4313 $\frac{1}{2}$ —Bronze Metal..... " 0.00

SASH WEIGHTS

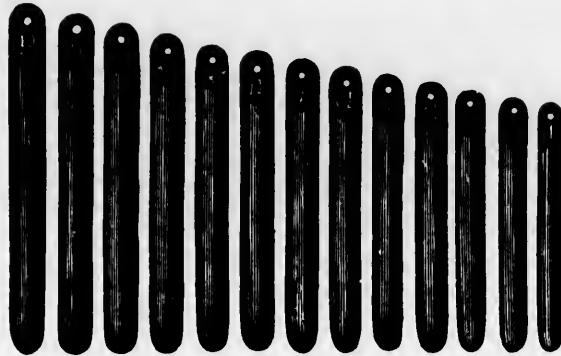

SOLID



SECTIONAL

Solid, Cast Iron, Regular Stock Sizes, 3 to 20 lbs. each per 100 lbs. \$4.00
 Sectional, " " " ½, ¾ and 1 lb. " " 6.00

TABLE OF WEIGHTS

Solid.....	3	3½	4	4½	5	6	7	8	9	10	11	12	13	14	15	16	17	18	19	20	lbs.
Diameter.....	1½	1½	1½	1½	1½	1½	1½	1½	1½	1½	1½	1½	1½	1½	1½	1½	1½	1½	1½	1½	inches.
Length.....	6	6½	7½	8½	9½	11	13	15	17	19	20½	22½	24½	26	28	30	32	34	35½	36½	"

WEIGHT OF WINDOWS

Size of Glass.....	12x20	12x24	12x28	12x32	12x36	13x26	13x32	13x36	14x24	14x32	14x36	14x40	inches.	
Four Lights, per Window.....	16	18	20	22	24	22	24	26	22	26	28	30	lbs.	
Size of Glass.....	20x30	20x34	22x28	22x34	24x26	24x32	24x36	26x30	26x36	26x40	28x30	28x36	28x40	inches.
Two Lights, per Window....	18	22	20	24	20	22	24	22	26	28	24	28	30	lbs.

NOTE.—In hanging window sashes, four Sash Weights of one-fourth above weights are required for each window. Above estimates are based on 1½ inch Sash with Star Glass. Star Glass averages 1 lb. to the square foot; Double Diamond Glass, 1½ lbs.; Plate Glass, 4 lbs.

SASH CORD IRONS

Full size cuts.



No. 1



No. 3

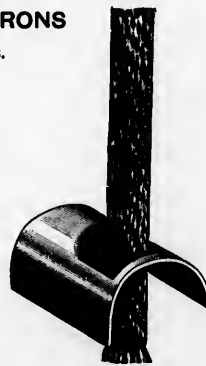

No. 574



No. 574

No. 1—Cast Iron, to Screw on per gross \$0.90
 " 3— " Drive, without Screws " 1.00
 " 574—Steel, Coppered, for Rope or Chain " 1.00

One gross in a box.

No. 31
" N31

No. 32
" N32
" 222

FLU

No. 1
" 2
" 603
" 603
" 604

SASH PLATES AND SOCKETS

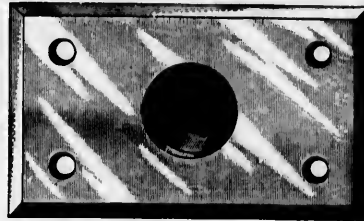
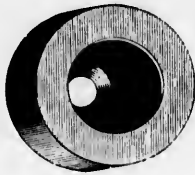

Nos. 3186 $\frac{1}{2}$ and 2186 $\frac{1}{2}$

No. 1289

No. 3186 $\frac{1}{2}$ —Iron, Amber Bronzed Sash Socket	Per doz. \$0.45	No. 2186 $\frac{1}{2}$ —Bronze Metal Sash Socket	Per doz. \$0.00
" N3186 $\frac{1}{2}$ — " Bronze Plated " "	0.65	" 1289— " " Sash Plate	2.70

SASH PULL HOOK

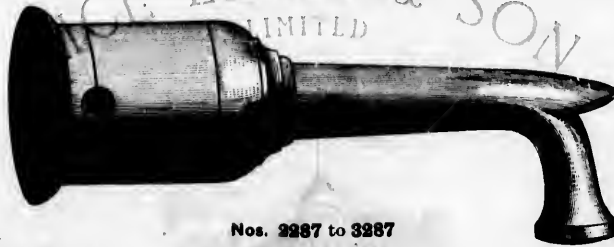

Nos. 3287 to 3287

No. 3287—Iron, Amber Bronzed	per doz.	1.45
" N3287—1" Bronze-Plated, Plain	"	4.15
" 2287—Bronze Metal	"	6.50

SASH CENTRES

FLUSH SASH CENTRES



SURFACE SASH CENTRES

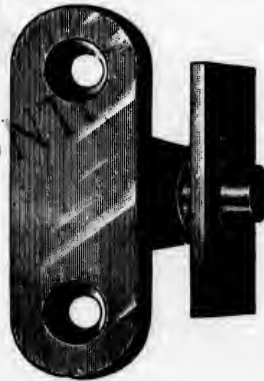

No. 1

No. 2

No. 603

No. 1—Iron, Japanned, 4 Pieces in a Set	per gross sets	\$ 5.00
" 2— " " " " " " " " " " " "	"	10.50
" 602— " Bronzed, 4 " " " " " " " " " "	per doz sets	0.90
" 603— " " " " " " " " " " " "	"	1.40
" 604— " " " " " " " " " " " "	"	2.50

PATENT SASH CENTRE OR PIVOT



No. 1305. Half Set.

Special attention of Architects and Builders is called to this novel invention, enabling anyone to hang a sash from the central point either upright or horizontal. Directions—Place one half with the pin at either end of the sash, secure one arm to the sash frame, fit the other pivot, put them in the sash and place in position, turn at right angles and make secure.

No. 1305—Malleable Cast, with Turned Centres per doz. sets \$10.80
 " 1305½—Bronze Metal, Steel Pin and Bushing, Turned Centres " " 24.00

SASH ROLLERS



No. 10



No. 593

Size	5/8	3/4	7/8	1	1 1/4	1 1/2 inch.
No. 10—Iron, Japanned..... per gross	\$2.50	3.00	4.00	5.00	6.50
" 593— " " heavy..... " "	7.00	10.80	17.30

SHUTTER BARS

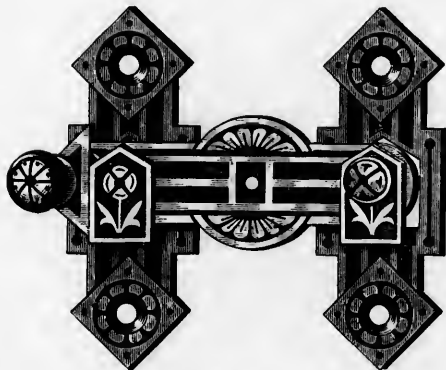

No. T185A

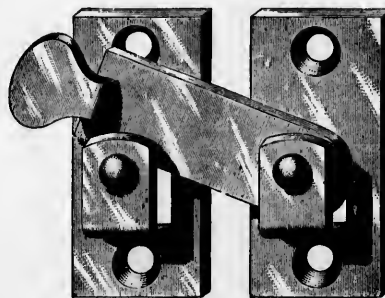

Nos. 937 to 937½

No. T185A—2½ inch, Amber Bronzed, with Bronze Metal Knob..... per doz.	\$1.40
" 937—2 " Wrought Steel, Amber Bronzed..... "	0.00
" N937—2 " " " Bronze-Plated..... "	1.80
" 937½—2 " Bronze Metal..... "	2.20

PORCELAIN SHUTTER AND DRAWER KNOBS

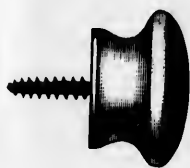

No. 1, 1 inch.

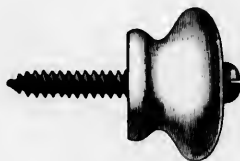

No. 15, 1 inch.

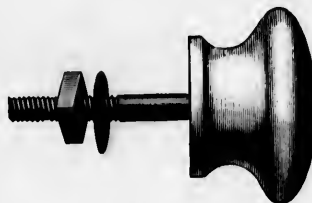

No. 5, 1 1/2 inch.

Size		3/4	1	1 1/4	1 1/2	1 3/4	2 inch.
No. 1—With Fast Screw	per gross	\$2.85	3.00	3.40	4.80	6.00
" 15—With Round Head, Tinned Screw	"	2.00	2.20	2.40	3.40	4.20	6.20 7.40
" 5—Drawer Knob, with Bolt	"	6.30	8.00	9.20	11.40 13.00

SHUTTER KNOBS

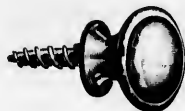

No. 1534, 3/4 inch.



No. 1534, 1 inch.

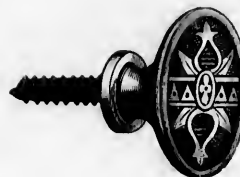

No. 3170

Size		3/4	1	1 1/2	1 3/4 inch.
No. 1534—Plain Bronze	per doz.	\$0.90	0.90	0.90	2.20
" 3170—Amber Bronzed	"	0.35
" P3170—Persian Bronzed (14 Finish)	"	0.90

PICTURE KNOBS

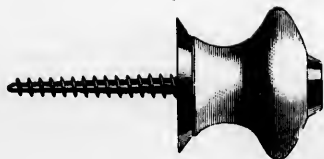

No. 122



No. 122 1/2

No. 122 —1 inch, Porcelain, Nickel Trimmings	per gross	\$5.00
" 122 1/2—1 " Jet, " "	"	5.00

DOOR BUTTONS



No. 10, 1 1/4 inch.



No. 4855, 1 1/2 inch.

Size.....	1 1/4	1 1/2	1 3/4	2	2 1/4	2 1/2 inch.
No. 10—Iron, Japanned..... per gross	\$0.55	0.60	0.70	0.90	1.30	1.70
" 4855—Brass, Lacquered..... "	2.00	3.80

One gross in a box.



No. 20, 1 1/2 inch.



No. 32, 2 inch.

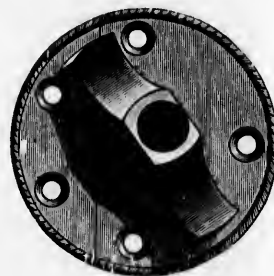

No. 186, 1 1/2 inch.

Size.....	1 1/2	1 3/4	2 inch.
No. 20—Iron, Japanned..... per gross	\$3.00	3.20	3.50
" 25— " " (as No. 20, with Spring)..... "	3.80
" 32— " Bronzed..... "	6.00
" 186—Brass, Lacquered..... "	14.40	16.80

Half gross in a box.

ELBOW CATCH

For Cupboard Doors.

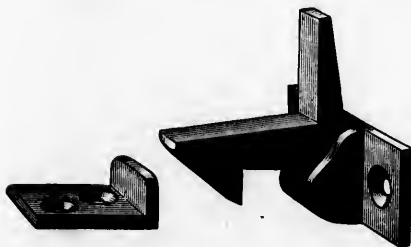

Nos. 6300 and 1623

LEVER CATCH

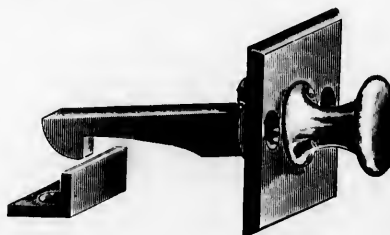

No. 329

No. 6300—Iron, Japanned.....	per doz.	\$0.60
" 1623—Brass, Polished.....	"	2.00
" 329—Bronze Metal.....	"	3.60

No. 102
" 102

No. 102
" 103

No. 1035
" 1036

REFRIGERATOR CATCHES

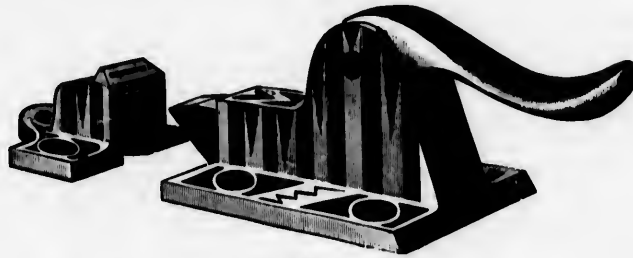

Nos. 1020 and 1023

No. 1020—1½ inch, Amber Bronzed	per doz.	\$3.00
" 1023—2 inch, " "	"	4.00

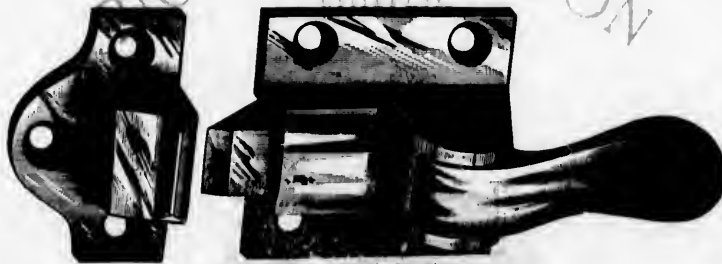

Nos. 1029 and 1031

No. 1029—2 inch, Bronze Metal, Polished	per doz.	11.00
" 1031—2 " " " Nickel-Plated	"	12.00



Nos. 1035 and 1036, Left Hand Catch. Full size cut.

No. 1035—Bronze Metal, Polished	per doz.	16.00
" 1036— " " " Nickel-Plated	"	18.00

Half-dozen in a box.

When ordering, mention Hand wanted.

½ inch.
70

2 inch.
50
..
60
80

\$0.60
2.00
3.60

SPRING DOOR CATCHES

Full size cuts.

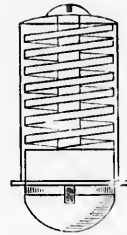
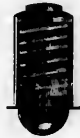

No. 85

No. 11P

No. 13

No. 85	— Catch, with Brass Shell, with either Square or Round Brass Striker.....	per gross	\$ 8.45
" 85S	— " " " " " " " Steel "	"	7.00
" 11P	— " " " " " " " Brass "	"	19.75
" 13	— " " " " with Square Iron Striker	"	33.75

One gross in a box.

The No. 85 cannot be extended as in Nos. 11P and 13. No. 11P is noiseless, suitable for Pianoforte Desks; in construction two leather collars are placed inside the shell, one at each end of the spring; these collars are made to fit tightly and prevent any looseness or rattle of the various parts. In addition to these there is also a leather collar placed outside between the shell and the head of the screw.



No. 1084

No. 1084	— Brass Catch, with Square Brass Striker, $1\frac{1}{4} \times \frac{3}{4}$ inch	per gross	\$21.50
" 1121	— " " Angle " " " $1\frac{1}{4} \times \frac{3}{4}$ "	"	13.00

Half gross in a box.

FRENCH WINDOW CATCHES

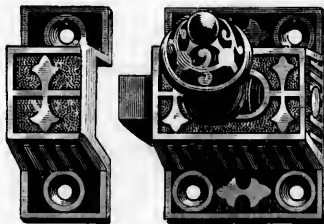

No. 3210

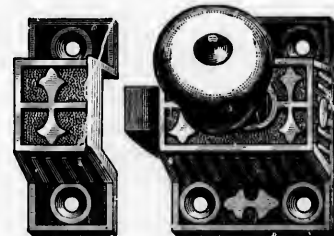

No. 3215

No. 3210	— Amber Bronzed, with Bronze Metal Knob	per gross	10.00
" 3215	— " " " Porcelain Knob	"	11.00

One-sixth gross in a box.

FRENCH WINDOW AND CUPBOARD CATCHES

Full size cuts.

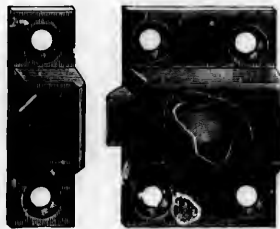

Nos. N13270 and 2270 1/2

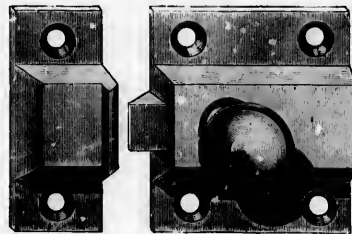

No. 2271 1/2

No. N13270	—Bronze-Plated	per doz.	\$1.80
" 2270 1/2	—Bronze Metal	"	3.60
" 2271 1/2	— " "	"	4.00
" 2272 1/2	— " "	size 1 1/2 x 1 1/2 inches, as No. 2271 1/2	"	4.50

gross \$ 8.45
7.00
19.75
33.75

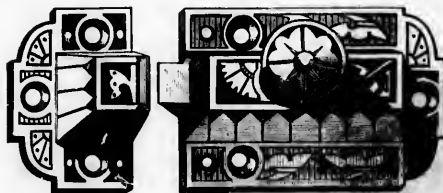

No. 1260

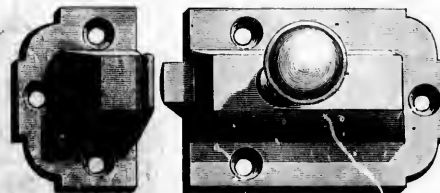

No. N13029

No. 1260	—Amber Bronzed, with Bronze Metal Knob	per gross	9.50
" N13029	—Bronze-Plated, " " " "	"	22.50

One dozen in a box.

gross \$21.50
13.00

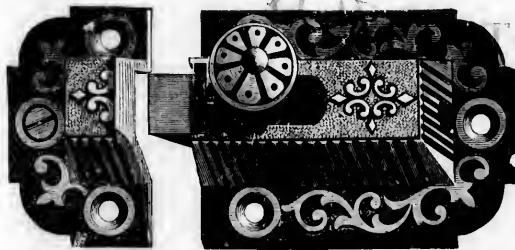

No. 262



No. 267

No. 262	—Amber Bronzed, with Bronze Metal Knob	per gross	9.50
" 267	— " " " " Porcelain Knob	"	11.20

One-sixth gross in a box, with Screws.

gross 10.00
11.00

CUPBOARD CATCHES AND TURNS

Full size cuts.

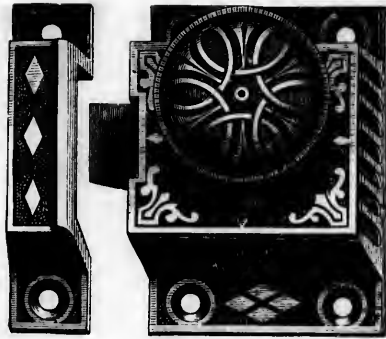

Nos. T4230 and T4430

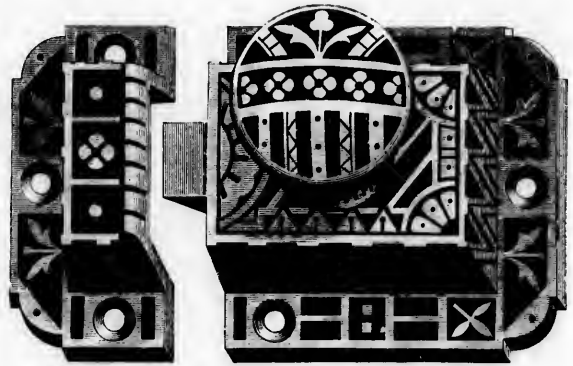

Nos. T4250A and T4450A

No. T4230 — Amber Bronzed	per doz.	\$1.80
“ T4430 — “ “ with Bronze Metal Knob	“	2.00
“ T4250A — “ “	“	2.40
“ T4450A — “ “ with Bronze Metal Knob	“	2.00

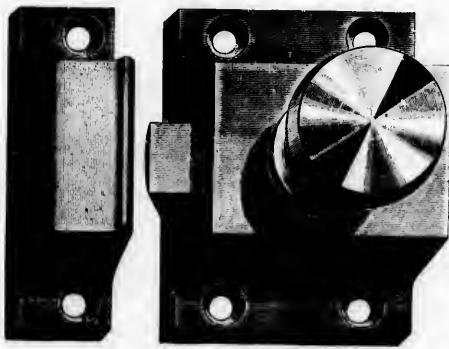

Nos. N13041 and 2241½

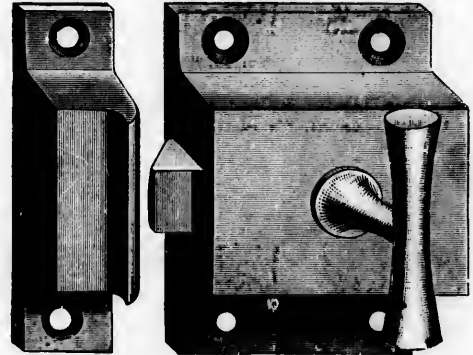

Nos. N13039 and 2039½

No. N13041 — Bronze-Plated	per doz.	4.00
“ 2241½ — “ Metal	“	7.20
“ N13042 — “ Plated (heavier)	“	4.85
“ 2242½ — “ Metal	“	8.00
“ N13039 — “ Plated, with Bronze Metal T Handle	“	4.50
“ 2039½ — “ Metal, “ “ “	“	7.20

One dozen in a box, with Screws.

CUPBOARD TURNS

Full size cuts.

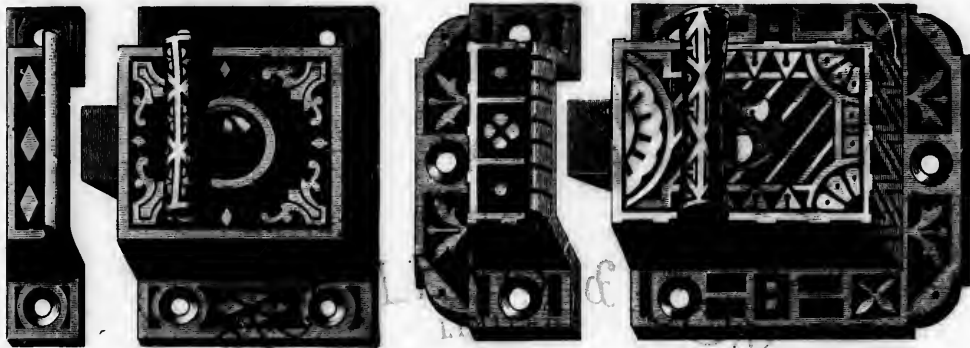

Nos. 4432 and P3039

No. 4452A

No. 4432	—Amber Bronzed, with Bronze Metal T Handle	per doz.	\$2.40
" P3039	—Persian " (14 Finish), with Bronze Metal T Handle	"	3.00
" 4452A	—Amber " with Bronze Metal T Handle	"	3.70

TRANSOM CATCHES

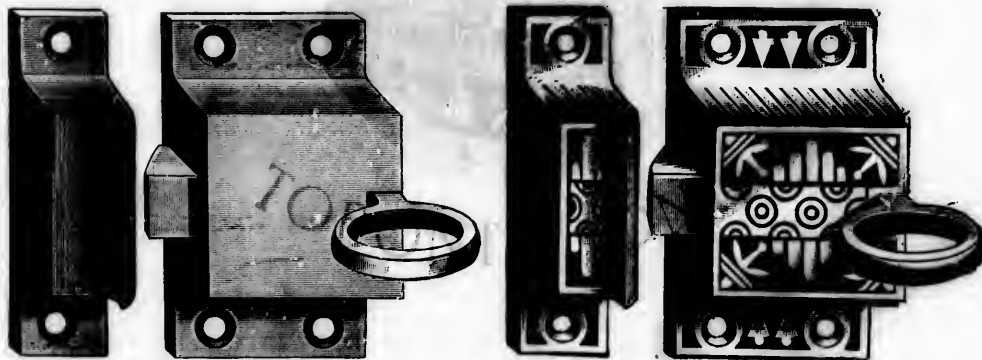

No. 2278 $\frac{1}{2}$

Nos. 3278 to P3278

No. 2278 $\frac{1}{2}$	—Bronze Metal	per doz.	7.20
" 3278	—Amber Bronzed	"	1.00
" 3278 $\frac{1}{2}$	— " " with Flush Strike	"	1.00
" P3278	—Persian Bronzed (14 Finish)	"	2.50

One dozen in a box, with Screws.

TRANSOM CHAINS

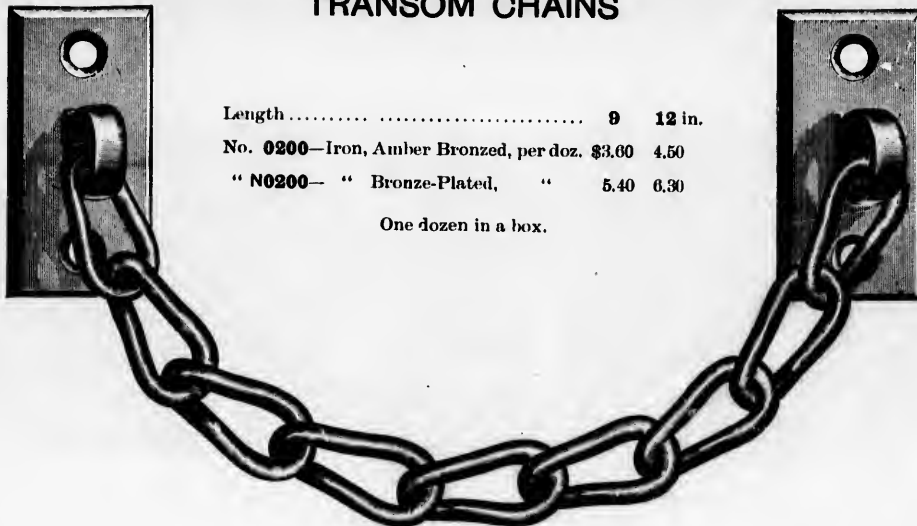

Length 9 12 in.
 No. **0200**—Iron, Amber Bronzed, per doz. \$3.60 4.50
 " **N0200**— " Bronze-Plated, " 5.40 6.30

One dozen in a box.

CASEMENT FASTENERS

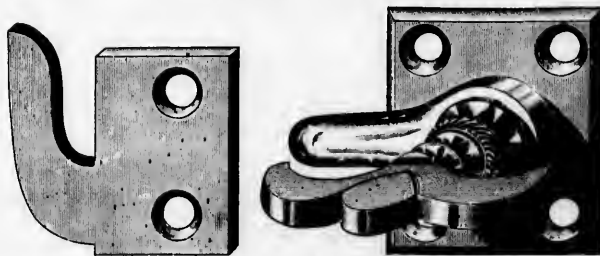

No. **02160**

No. **02160**—Bronze Metal, with Screws.....per doz. \$9.00
 " **4681**—Brass, with Lever Handle....." 5.00

CASEMENT ADJUSTERS

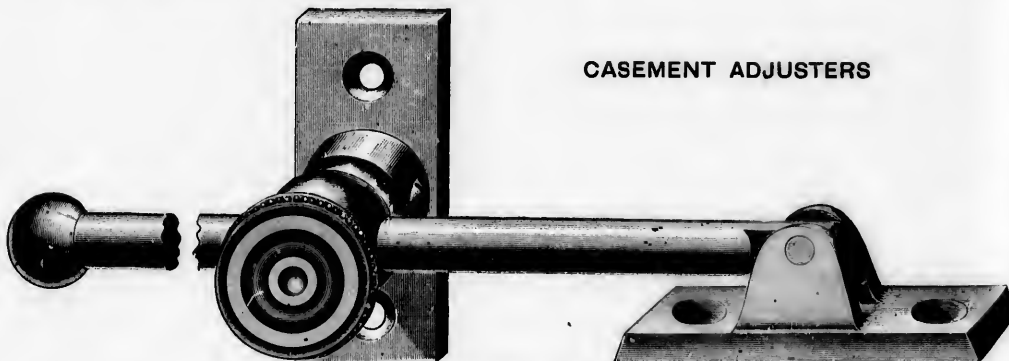

Nos. **043½** and **43½**

No. **043½**—12 inch Rod, Iron, Coppered.....per doz. 8.00
 " **N043½**—12 " " Bronze-Plated....." 9.35
 " **43½**—12 " " Bronze Metal....." 20.70

One-third dozen in a box.

Size .
 No. A
 " A
 lever
 and s
 the s
 curta

Size .
 No. 1

Size .
 Opens
 No. 1
 " 1
 large

CARTLAND'S PATENT WINDOW OPENERS

Suitable for all kinds of Fanlights, Pivot Sashes, Skylights, etc.



WINDOW CLOSED AND LOCKED



WINDOW PARTLY OPEN

Size		12	14	16	18	24 inch.
No. A2741 —Malleable Iron	each	\$1.90	2.15	2.40	2.70	3.20
" A2740 —All Brass	"	2.00	3.20	3.60	4.00	5.30

ADVANTAGES:—The action of this Window Opener is very simple. By pulling an endless cord a weighted lever is lifted out of gear, releasing the cog wheel, while by loosening the cord it throws the lever into gear again and securely locks the sash so that rattling, or shaking of the Fanlight, is entirely obviated. To close the window the same action is reversed by pulling the other cord. In this pattern the stay falls down out of the way of blinds curtains, etc.

In erecting, fix the plates as close together as possible, without touching.

VERITY'S EPICYCLOIDAL FANLIGHT OPENERS

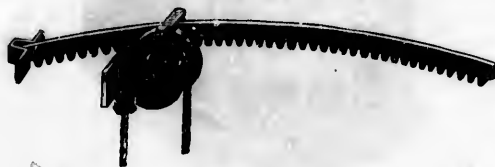

No. 1013

Size		12	16	18	20 inch.
No. 1013 —Malleable Iron, Gun Metal Wheel.....	each	\$2.70	3.00	3.30	3.60

LEGGOTT'S FANLIGHT OPENERS



No. 1501

Size		12	16	21 inch.
Opens		10	14	18 "
No. 1501 —Malleable Iron, Gun Metal Wheel.....	each	\$1.50	2.15	4.00
" 1501B —All Brass	"	2.15	3.20	7.90

The 12 inch is suitable for Fanlights 2 ft. square or equal area; 16 inch, 3 ft. square or equal area; 21 inch, for large and very heavy Fanlights.

TRANSOM LIFTERS

PAYSON'S SOLID GRIP TRANSOM LIFTERS

BRONZED IRON

STEEL BRACKET AND LOCK

BRASS TRIMMINGS

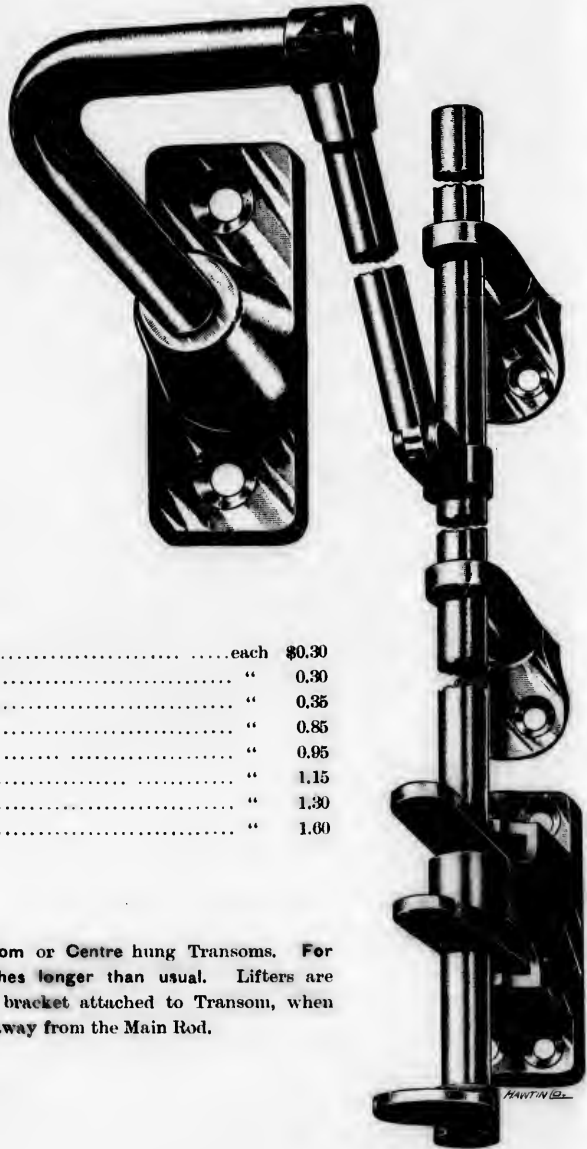

No. 503— $\frac{1}{8}$ inch Rod, length 3 feet.....	each	\$0.30
" 303— $\frac{1}{4}$ " " " 3 "	"	0.30
" 304— $\frac{1}{2}$ " " " 4 "	"	0.35
" 314— $\frac{3}{8}$ " " " 4 "	"	0.85
" 315— $\frac{1}{2}$ " " " 5 "	"	0.95
" 325— $\frac{3}{4}$ " " " 5 "	"	1.15
" 326— $\frac{7}{8}$ " " " 6 "	"	1.30
" 328— $\frac{1}{2}$ " " " 8 "	"	1.60

These Lifters can be used for Top, Bottom or Centre hung Transoms. For Bottom hung sash always order lifts 18 inches longer than usual. Lifters are measured from the handle at bottom to the bracket attached to Transom, when the short Connecting Rod is extended up and away from the Main Rod.

TRANSOM LIFTERS

CORBIN'S



HINGED AT TOP



HUNG ON CENTRES



HINGED AT BOTTOM

FOR TRANSOMS HINGED AT TOP OR HUNG ON CENTRES

Length		3	4	5	6 feet.
No. 083— $\frac{1}{8}$ inch Rod, Iron, Bronzed	each	\$0.35	0.35
" 084— $\frac{1}{8}$ " " "	"	...	0.65
" 085— $\frac{3}{8}$ " " "	"	1.00	1.15
" R083— $\frac{1}{8}$ " " Polished, Oxidized Copper	"	0.80	0.60
" R084— $\frac{1}{8}$ " " " " "	"	...	1.00
" R085— $\frac{3}{8}$ " " " " "	"	1.30	1.45

FOR TRANSOMS HINGED AT BOTTOM

Length		3	4	5	6 feet.
No. 083— $\frac{1}{8}$ inch Rod, Iron, Bronzed	each	\$0.45	0.50	0.65	...
" 084— $\frac{1}{8}$ " " "	"	...	0.80	0.90	1.00
" 085— $\frac{3}{8}$ " " "	"	1.00	1.30
" R083— $\frac{1}{8}$ " " Polished, Oxidized Copper	"	0.80	0.90	1.00	...
" R084— $\frac{1}{8}$ " " " " "	"	...	1.00	1.30	1.45
" R085— $\frac{3}{8}$ " " " " "	"	1.45	1.65

In ordering Transom Lifters Hung at the Bottom, have Rod 12 to 18 inches longer than where used for Top or Centre Hung Sashes.

CHEST HANDLES

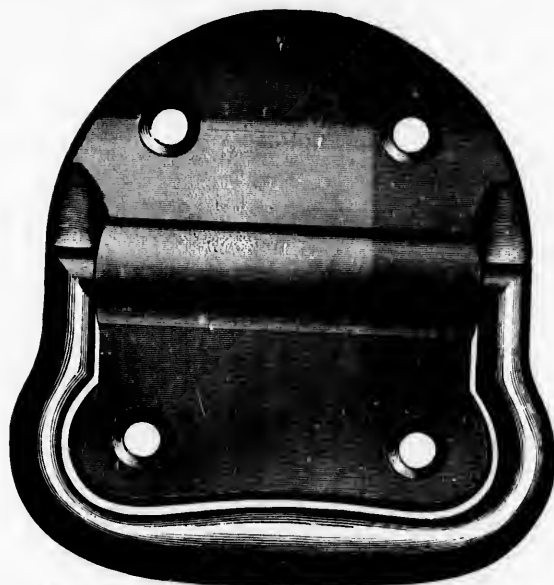

No. 10—3 $\frac{1}{4}$ inch, Cast Iron, Japanned	per doz. pairs	\$1.25
“ 11—3 $\frac{1}{2}$ “ “ “	“ “	1.80
“ 12—4 “ “ “	“ “	2.60
“ 13—4 $\frac{1}{2}$ “ “ “	“ “	3.30

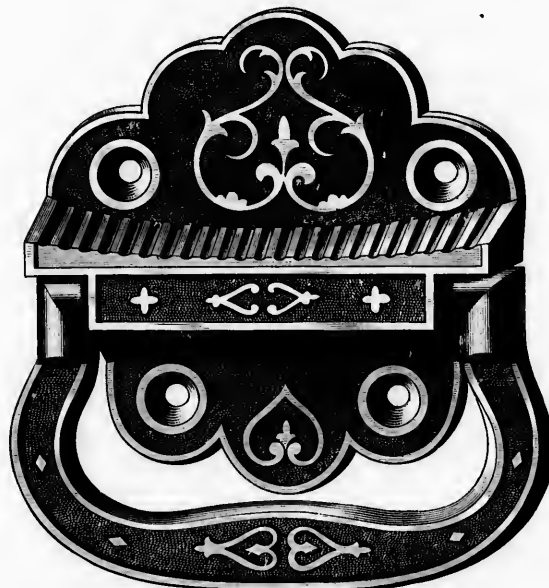

No. 220—2 $\frac{3}{4}$ inch, Amber Bronzed, Packed with Screws	per doz. pairs	2.30
“ 221—3 $\frac{1}{4}$ “ “ “ “	“ “	3.00

Half-dozen pair in a box.

WROUGHT IRON CHEST HANDLES

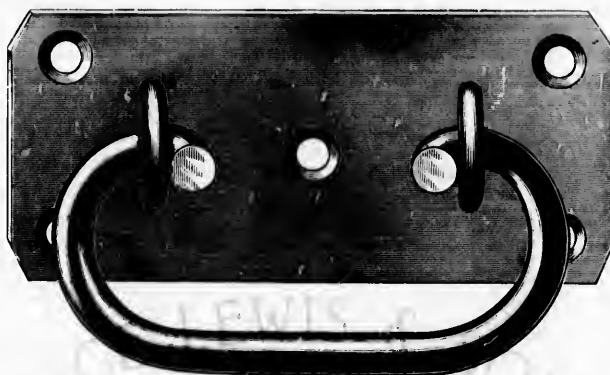

Nos.	1	2	3
Size.	4	4½	4¾ inch.
Per dozen pairs	\$0.65	0.75	0.90

One dozen pairs in a box.

z. pairs \$1.25
 " 1.80
 " 2.60
 " 3.30

FLUSH CHEST HANDLES



Nos. 2 and 3

FLUSH TRAP DOOR RINGS



No. 4. Full size cut.

pairs 2.30
 3.00

No. 2—4¾ x 3¾ inch, Japanned.....	per doz. pairs	3.00
" 3—5½ x 4½ " "	" "	3.00
" 4—Flush Trap Door Rings, Japanned.....	per single doz.	1.20

DRAWER PULLS



No. 100. Full size cut.

No. 100—Japanned per gross \$2.10



Nos. 10 and 101. Full size cut.

No. 10—Japanned per gross 3.00
 " 101—Coppered " 3.20

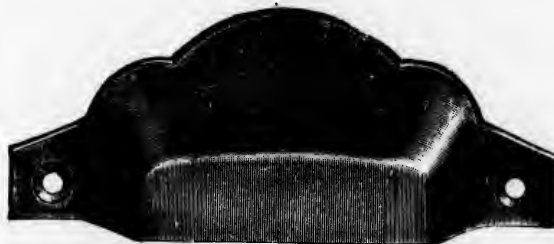

No. 01. Full size cut.

No. 01—Japanned per gross 2.00

Quarter gross in a box.

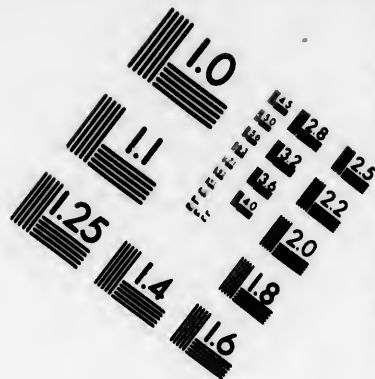
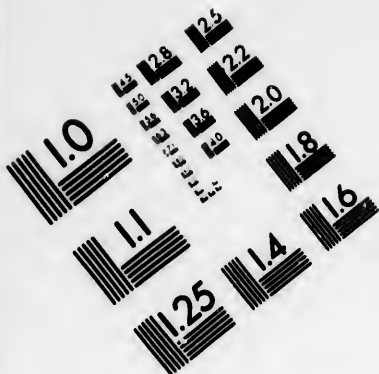

**IMAGE EVALUATION
TEST TARGET (MT-3)**

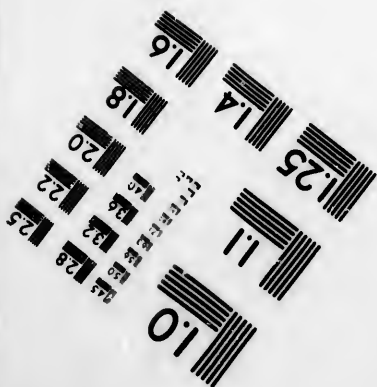
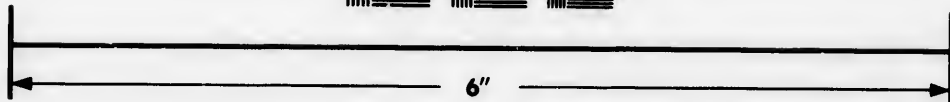
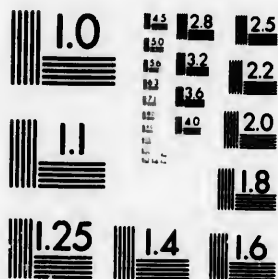

**Photographic
Sciences
Corporation**

23 WEST MAIN STREET
WEBSTER, N.Y. 14580
(716) 872-4503

LE 128
E E E 132
E 136
E 140
E 144
E 148

11
10
E

DRAWER PULLS



No. 4432. Full size cut.

No. 4432	- 3 1/4 inch, Bronze-Plated (10 Finish)	per gross	\$7.50
" 4433	- 3 1/2 " " " "	" "	8 00

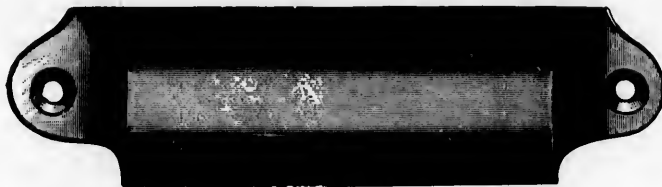

No. 4435. Full size cut.

No. 4435	- 3 1/4 inch, Bronze-Plated	per gross	8.00
" 4436	- 4 " " "	" "	8.50



No. 1241 1/2. Full size cut.

No. 1240 1/2	- 3 inch, Bronze Metal (Cast)	per doz.	3.00
" 1241 1/2	- 3 1/2 " " " "	" "	3.25
" 1242 1/2	- 3 3/4 " " " "	" "	3.00

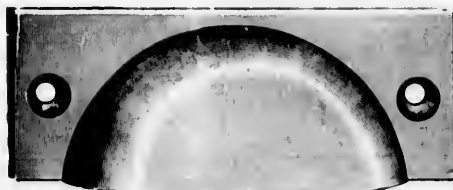

Nos. 1362 and 1363

No. 1362	- 2 1/4 inch, Wrought Bronze Metal	per doz.	1.15
" 1363	- 3 1/4 " " " "	" "	1.25
" 2107 1/2	- 2 1/4 " " " "	" "	1.15
" 2106 1/2	- 3 1/4 " " " "	" "	1.35
" 2103 1/2	- 3 1/2 " " " "	" "	1.50

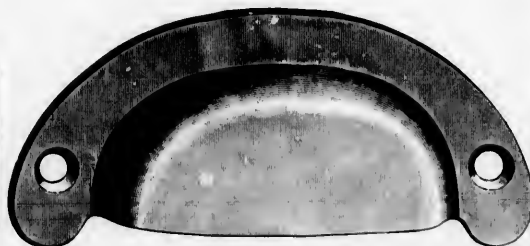

Nos. 2107 1/2 to 2103 1/2

Three dozen in a box.

DRUGGIST DRAWER PULLS



No. 586. Full size cut.

No. 586—Amber Bronzed, with Screws, size of Label $\frac{1}{2}$ x 2 inch.....per gross \$7.00



No. T3439. Full size cut.

No. T3439—Amber Bronzed, with Screws.....per gross 0.50



No. 348. Full size cut.

No. 348—Amber Bronzed, with Screws, size of Label $\frac{1}{2}$ x 2 $\frac{1}{2}$ inch.....per gross 10.40

Quarter gross in a box.

\$7.50
8 00

8.00
8.50

3.00
3.25
3.60

1.15
1.25
1.15
1.35
1.50

RICE LEWIS & SON
LIMITED

CARD HOLDERS



No. 741. Full size cut.



No. 743. Full size cut

No. 741—Wrought Bronze Card Holder and Pull.....	per doz.	\$1.35
" 743— " Brass "	"	0.55



No. 402. Full size cut.

No. 402—Dark Antique.....	per gross	7.20
---------------------------	-----------	------

FLUSH RING

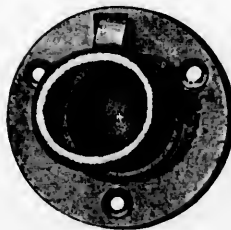

No. 1181, 1 1/2 inch.

LOCKER RINGS



No. 1689

FLUSH RING



No. 1179

No. 1181—1 1/2 inch, Brass Flush Rings, with Round Ring.....	per doz.	\$2.00
" 1181—1 1/2 " " " " " " "	"	2.15
" 1179—1 " " " " " " " "	"	1.45
" 1179—1 1/2 " " " " " " " "	"	1.85
" 1179—1 1/2 " " " " " " " "	"	2.20
" 1689—2 1/2 " " Locker Rings, " "	"	3.20

BRASS CASH BOX HANDLES

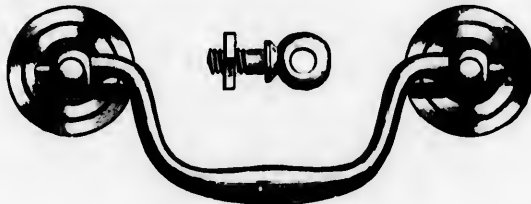

No. 5482

Size.....		3	3½ inch.
No. 5482—Cast Brass, Polished and Lacquered.....	per doz.	\$4.00	4.90

RICE LEWIS & SON
 TORONTO, ONT.
BRASS LIFTING HANDLES



No. 8090

Size.....		2¼	2¾ inch.
No. 8090—Cast Brass, Polished and Lacquered.....	per doz.	\$1.90	2.30

FLUSH DRAWER HANDLES



No. 8282

No. 8282—4¼ x 2¼ inch Plate, Cast Brass, Polished and Lacquered.....	per doz.	\$6.70
" 8283—4 x 2 " " " " " " " "	"	4.90

No. 8283 has Oval Handle in place of Square, as shown in cut.

\$1.35
0.55

7.20

\$2.00
2.15
1.45
1.85
2.20
3.20

CABINET DRAWER PULLS

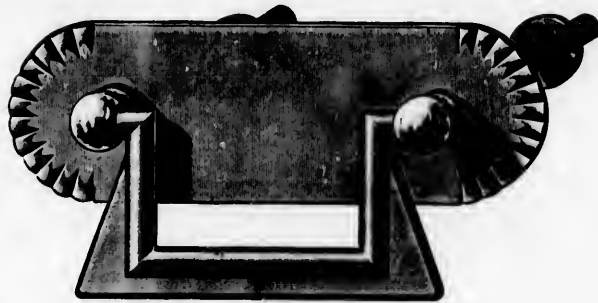

No. 01720

No. 01720—1 1/2 x 3 1/2 inch Plate, Bronze Metal..... per pair \$1.35

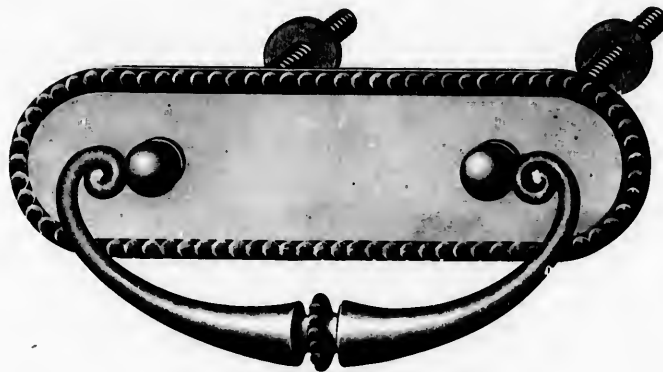

No. 01417

No. 01417—1 3/8 x 4 1/4 inch Plate, Bronze Metal..... per pair 2.25

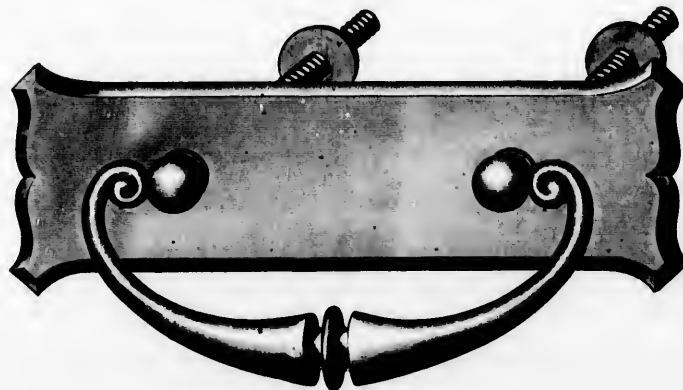

No. 2846 1/2

No. 2846 1/2—1 1/8 x 4 1/4 inch Plate, Bronze Metal..... per pair 2.25

No. 14

No. 118

No. 118

CABINET DRAWER PULLS

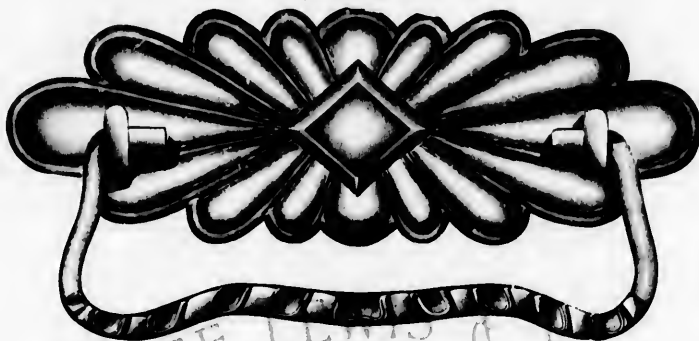

No. 1452—Brass or Oxidized..... per doz. \$0.60



No. 1188—Brass or Oxidized..... per doz. 0.75



No. 1186—Brass or Oxidized..... per doz. 0.90

CABINET DRAWER PULLS

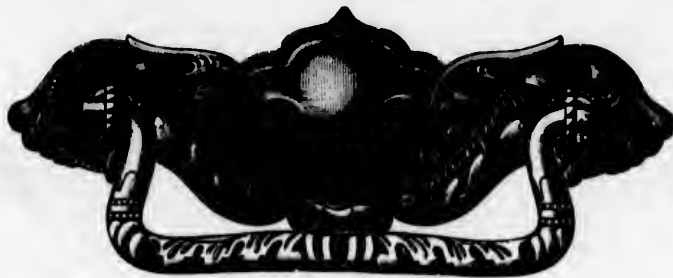

No. 1172—Brass or Oxidized.....per doz. \$0.90



No. 10008—Brass.....per doz. 1.35



No. 10005—Brass.....per doz. 3.00

No. 1
" 1



Nos. ...
Cast Br

CABINET DRAWER PULLS

Full size cuts.



No. 10000



No. 10001

No. 10000—Cast Brass.....	per doz.	\$1.90
" 10001—Cast Brass.....	"	2.25



Nos. 4436



4865



4775



4833

Nos.....	4436	4865	4775	4833
Cast Brass.....per doz.	\$1.30	3.75	2.00	2.40

RING DRAWER PULLS

Full size cuts.



No. 1170



No. 1184

No. 1170—Nickel or Gilt.....	per doz.	\$0.45
" 1184— " ".....	"	0.55



No. 28



No. 24



No. 4166

No. 28—Brass Box Ring, Dipped Base, 1/4 inch Ring.....	per doz.	0.40
" 24— " " " Polished " " ".....	"	0.50
" 4166—Cast Brass Pull, with Bolt and Nut.....	"	1.50

DROP HANDLES



No. 069

No. 069—Ebony and Gilt, 1 1/2 inch Knob.....	per doz.	1.00
" 070— " " " 1 1/2 " " ".....	"	1.00

COMMODE BUTTONS



No. 321

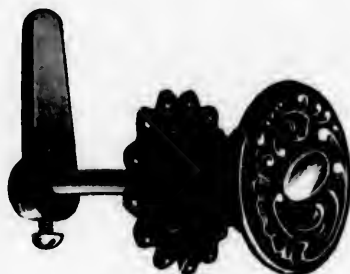

No. 1385

No. 321—Ebony and Gilt per doz. \$0.05
 " 1385—Brass, 1½ inch..... " " 1.10

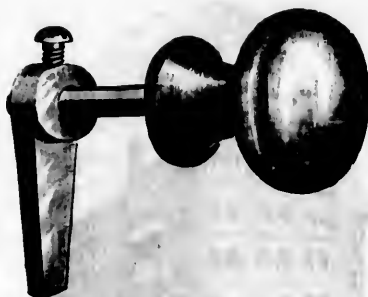

No. 2373

No. 2373—Porcelain Knob, 1½ inch, Brown, Black or White..... per doz. 2.00

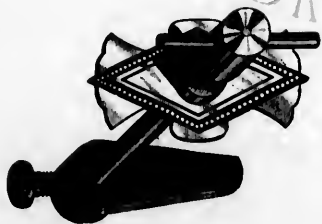

No. 922



No. 4645

No. 922..... per doz. 1.20
 " 4645..... " " 2.25

\$0.45
0.55

0.40
0.50
1.50

1.00
1.00

CABINET ESCUTCHEONS

CAST BRASS

Full size cuts.



No. 1167



No. 1728



No. 1844

No. 1167.....per doz. \$1.50 | No. 1728.....per doz. \$1.50 | No. 1844.....per doz. \$1.50

WROUGHT BRASS



No. 20



No. 713



No. 1412



No. 558

No. 20.....per gross \$1.10 | No. 1412.....per gross \$3.00
 " 713.....per gross 3.00 | " 558.....per gross 3.00

CABINET KNOBS AND PULLS

CAST BRASS



No. 1129

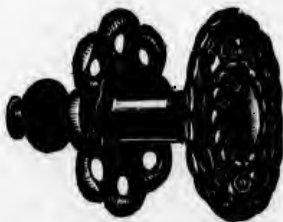

No. 1193



No. 1824

No. 1129.....per doz. \$1.10 | No. 1193.....per doz. \$2.70 | No. 1824.....per doz. \$2.00

CAST BRASS ORNAMENTS

Full size cuts.



No. 4657

No. 4657.....per doz. \$1.00



No. 4769

No. 4769.....



No. 4729

.....per doz. 2.10
 " 4729....." 2.40



No. 4672

No. 4672.....



No. 4755

" 4664.....



No. 4821

.....per doz. 1.15
 " 4664....." 2.05
 " 4755....." 1.35
 " 4821....." 2.25

BRASS BOX CORNERS AND STRAPS

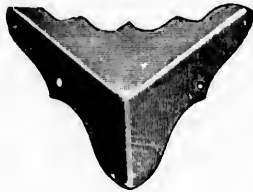

No. 480



No. 482

No. 480— $\frac{3}{4}$ x $1\frac{1}{4}$ inch, Polished Brass Corner..... per doz. \$1.10
 " 482— $1\frac{1}{2}$ x $1\frac{3}{4}$ " " " " " " " " " " " 1.80

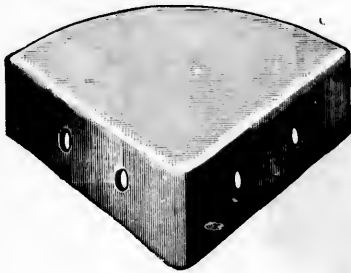

No. 484

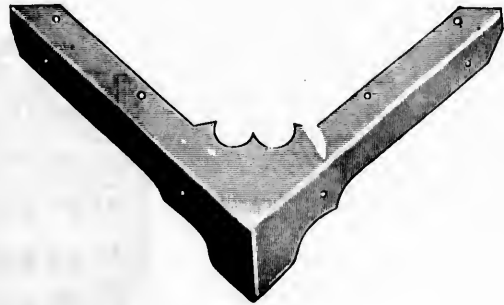

No. 481

No. 484— $\frac{1}{2}$ x $1\frac{1}{2}$ inch, Polished Brass Corner per doz. 2.15
 " 481— $\frac{3}{4}$ x $2\frac{1}{2}$ " " " " " " " " " " " 1.65

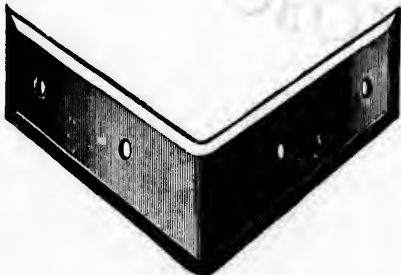

No. 472

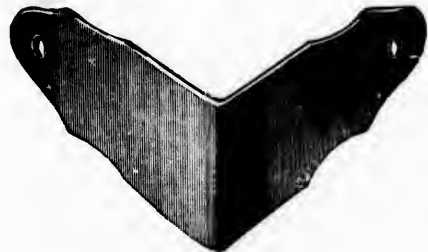

No. 475

No. 472— $\frac{1}{2}$ x $1\frac{1}{2}$ inch, Brass Corner Strap, Bevelled..... per doz. 2.70
 " 475— 1 x 2 " " " " " " " " " " " 1.80
 " 476— $1\frac{1}{2}$ x $2\frac{1}{2}$ " " " " " " " " " " " 2.70

STEEL CORNER IRONS



No. 999

Size
 No. 999—Bright Steel per single doz.



No. 998C

Size No. 998C—Brass Plated per single doz.	$\frac{1}{2} \times 2\frac{1}{2}$ \$0.15	$\frac{3}{4} \times 3\frac{1}{2}$ 0.22	1 x 5 inch. 0.32
Size No. 998C—Brass Plated per single doz.	$\frac{3}{4} \times 2$ \$0.70	$\frac{3}{4} \times 2$ \$0.70	1 x 2½ inch. 0.80

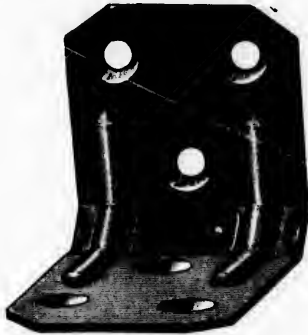

No. 997½

No. 997½—Plain Steel, 1½ x 1½ inch. per doz. \$0.30
 " 998 — " 1½ x 4½ " " 0.75



No. 996

SCREEN DOOR AND WINDOW BRACKETS

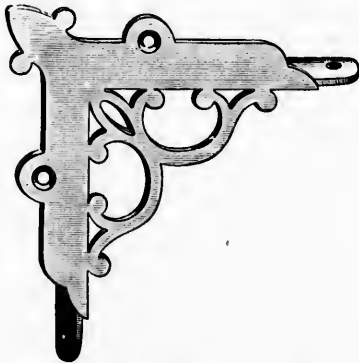

No. 202. Half size cut, showing Corner.

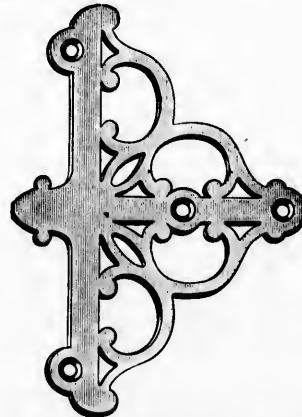

No. 202. Half size cut, showing Centre.

No. 202—Screen Door Brackets, Amber Bronzed, 4 Corner Brackets, with 2 Centre Pieces to the Set, with Screws per dozen sets 5.00
 " 100—Window Screen Brackets, 4 Corner Brackets, as No. 202, 3 x 3 in. for Window Screens. " " 2.00
 No. 202, quarter dozen ; No. 100, half-dozen sets in a box.

WROUGHT STEEL SHELF BRACKETS

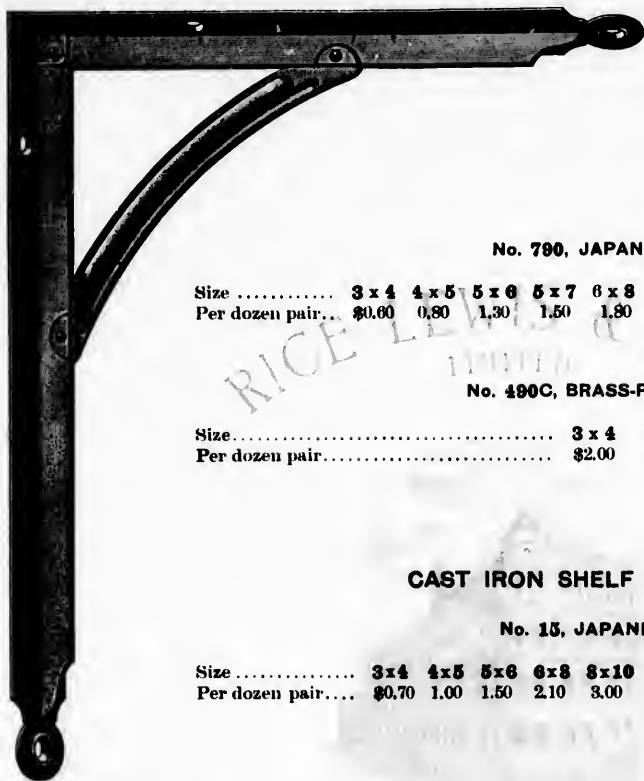

No. 790, JAPANNED

Size	3 x 4	4 x 5	5 x 6	5 x 7	6 x 8	7 x 9	8 x 10	10 x 12	12 x 14 inch.
Per dozen pair....	\$0.60	0.80	1.30	1.50	1.90	2.20	2.50	3.60	5.40

No. 490C, BRASS-PLATED

Size	3 x 4	4 x 5	5 x 6	6 x 8	8 x 10 inch.
Per dozen pair.....	\$2.00	2.40	3.00	4.00	5.40

CAST IRON SHELF BRACKETS

No. 15, JAPANNED

Size.....	3x4	4x5	5x6	6x8	8x10	10x12	12x14	14x18	16x20 inch.
Per dozen pair....	\$0.70	1.00	1.50	2.10	3.00	4.20	6.25	10.00	12.00



BRADLEY'S STEEL WIRE BRACKETS

JAPANNED

Size.....	4 x 5	5 x 7	6 x 8	7 x 9	8 x 10	10 x 12 inch.
Per dozen pair	\$0.70	1.30	1.60	2.00	2.30	3.20

TINNED ANGLE BRACKETS

Size.....	3 x 4	4 x 5	5 x 7 inch.
Per single dozen.....	\$0.30	0.50	0.60

Brackets 3x4 and 4x5, one dozen; 5x6 to 7x9, half-dozen; larger sizes, quarter dozen pairs in a box.

PAT. APR. 9, 1888.
NOV. 6, 1888.
APR. 2, 1890.

FLOWER POT BRACKETS

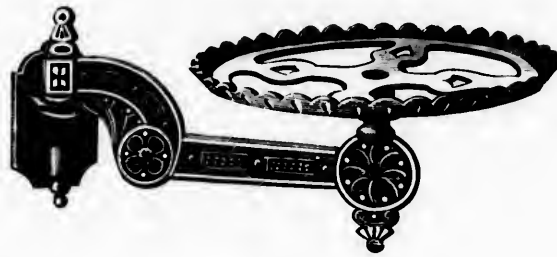

No. 1760

No. 1760—5 inch Arm, 4 inch Shelf, Maroon Finish..... per doz. \$2.00
One dozen in a box.

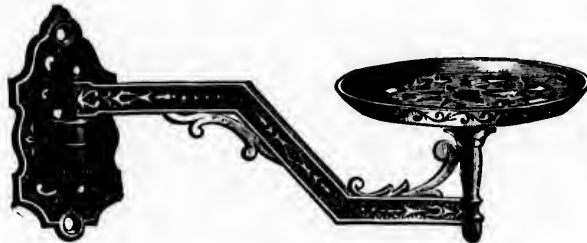

No. 2000

No. 2000—7 inch Arm, 4½ inch Shelf, Maroon Finish..... per doz. 3.50
One quarter dozen in a box, with Screws.



No. 1824

No. 1824—6 inch Arm, 5½ inch Shelf, Maroon Finish..... per doz. 5.20
One quarter dozen in a box, with Screws.

HAND RAIL BRACKETS

FOR BOX STAIRS



No. 1120 Japanned, 6 inch..... per doz. \$2.20
 " 1121- " 8 " " 2.40
 Half-dozen in a box.

TOWEL ROLLER BRACKETS



No. 55. Half size cut.

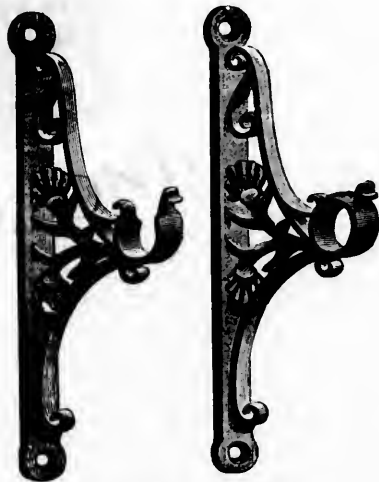

No. 2. Half size cut.

No. 55—Hand Rail Brackets..... per doz. \$1.50 | No. 2—Towel Roller Brackets, Coppered, per doz. pairs 2.40
 One dozen in a box.

z. \$2.00

z. 3.50

5.20

WROUGHT HAND RAIL SCREWS

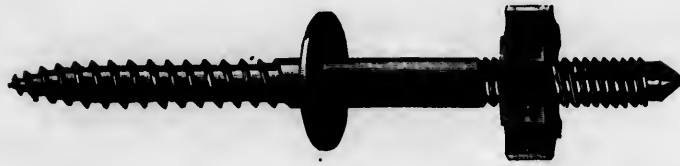

No. 51. Full size cut of 4½ inch.

No. 51— $\frac{1}{4}$ inch, Iron, 4½ inches long, 1 Nut, Gimlet Pointed Screw.....	per gross	\$5.00
" 51— $\frac{1}{4}$ " " Iron, 5 " " 1 " " " " " "		5.40



Nos. 52 and 62. Full size cut of 4½ inch, No. 52.

No. 52— $\frac{1}{4}$ inch, Iron, 4 inches long, 2 Nuts.....	per gross	5.10
" 52— $\frac{1}{4}$ " " Iron, 4½ " " 2 " " " " " "		5.40
" 52— $\frac{1}{4}$ " " Iron, 5 " " 2 " " " " " "		6.20
" 62— $\frac{1}{4}$ " " Iron, 6 " " 2 " " " " " "		8.40



No. 72. Full size cut of 4½ inch.

No. 72— $\frac{7}{8}$ inch, Iron, 4 inches long, 2 Nuts, Swelled Centre.....	per gross	8.40
" 72— $\frac{7}{8}$ " " Iron, 4½ " " 2 " " " " " "		9.00
" 72— $\frac{7}{8}$ " " Iron, 5 " " 2 " " " " " "		9.50

Quarter gross in a box.

Nos...
Iron H
" "
Brass P
" "

Nos...
Iron Pl
" "
" "
" "

Diamete
No. 12
" 12

Diamete
No. 551

Diamete
No. 557

CASTERS



PLATE CASTER



PHILADELPHIA PATTERN

LEWIS & CO. LIMITED

PLATE CASTERS

Nos.	1	2	3	4	5	6
Iron Horn, Iron Wheel.....	per set (4) \$0.12	0.14	0.16	0.18	0.22	0.27
" " Porcelain Wheel.....	" " 0.14	0.15	0.16	0.19	0.24
Brass Horn, Brass Wheel.....	" " 0.33	0.41	0.51	0.64	0.72	0.87
" " Porcelain Wheel.....	" " 0.24	0.28	0.34	0.40	0.44	0.52

PHILADELPHIA PATTERN

Nos.	1	2	3	4	5	6
Iron Plate, Horn and Wheel.....	per set (4) \$0.12	0.13	0.15	0.17	0.19	0.22
" " and Horn Porcelain Wheel.....	" " 0.14	0.15	0.17	0.19	0.21	0.24
" " Lignum-vitæ Wheel.....	" " 0.16	0.17	0.19	0.22	0.24	0.26
" " Brass Wheel.....	" " 0.25	0.28	0.34	0.42	0.44	0.58
" " Brass Horn and Wheel.....	" " 0.87	0.42	0.51	0.66	0.70	0.88

SHALLOW SOCKET AND SCREW CASTERS



No. 120, 1½ inch. Full size cut.



No. 5516, 1 inch. Full size cut.

Diameter of Socket.....	¾	1	1½	1¾ inch.
No. 120—Brass Socket, Horn and Wheel.....	per set (4) \$0.48	0.58	0.72	0.87
" 122— " " Porcelain ".....	" " 0.36	0.43	0.57	0.65
Diameter of Plate.....	¾	1	1½	1¾ inch.
No. 5516—Brass Horn, Vitrified Wheel.....	per set (4) \$0.52	0.58	0.60	0.76
Diameter.....	¾	1	1½	1¾ inch.
No. 5577½—Brass Caster Rings.....	per doz. sets \$1.30	1.45	1.75	2.00

\$5.00
5.40

5.10
5.40
6.20
8.40

8.40
9.00
9.50

DEEP SOCKET CASTERS



Diameter of Socket	1¼	1¾	1½ inch.
No. 5503—Brass Socket and Horn Vitrified Wheel	\$1.15	1.35	1.65
			per set (4)

STANDARD BALL-BEARING CASTERS



STEM CASTER



STEM SOCKET

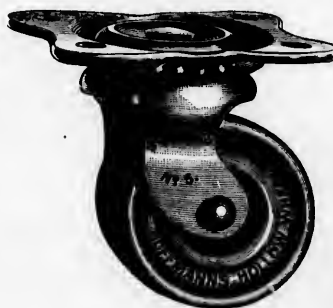

OBLONG PLATE



SECTION OF WHEEL

STANDARD STEM CASTERS

Nos.	3	5	7	8
Size of Wheel	1	1¼	1½	1¾ inch.
Style S—Steel Horn and Wheel	\$0.22	0.26	0.35	0.41
" L-- " " Lignum-vitæ Wheel	0.22	0.26	0.35	0.41
				per set (4)

Size of Small Socket, fitting Nos. 3 and 5, ¾ inch; Nos. 7 and 8, ⅞ inch.

STANDARD OBLONG PLATE CASTERS

Nos.	3	5	7	8
Size of Wheel	1	1¼	1½	1¾ inch.
Style S—Steel Plate and Horn Steel Wheel	\$0.23	0.31	0.48	0.67
" L-- " " Lignum-vitæ Wheel	0.23	0.31	0.48	0.67
				per set (4)

No. 33
" 33
" 62
" 01
" 022
" 020

Nos.
Size of B
With Pla
With Sla

GEM CASTERS



No. 333



No. 015



No. 0201

No. 333—Stem Plate, Iron Wheel.....	per set (4)	\$0.65
" 334— " " Lignum-vitæ Wheel (size as 333).....	"	0.70
" 020— " " Iron Wheel, Plate 2½ inch, Wheel 2 inch.....	"	1.15
" 015—1 inch, Brass Socket, Brass Wheel.....	"	3.00
" 0221—1½ " " " ".....	"	3.75
" 0201—1½ " " Square Socket, Brass Wheel.....	"	3.25

Can be supplied with Hard Rubber Tires to order.

BELL METAL GLASS BALL CASTERS



PLATE



SHANK

Nos.....	2	3	4
Size of Ball.....	1½	1¾	2¼ inch.
With Plate.....	\$1.55	1.95	3.90
With Shank.....	1.55	1.95	3.00

½ inch.
05



F WHEEL

8
1½ inch.
0.41
0.41

8
1½ inch.
0.67
0.67

STORE TRUCK CASTERS

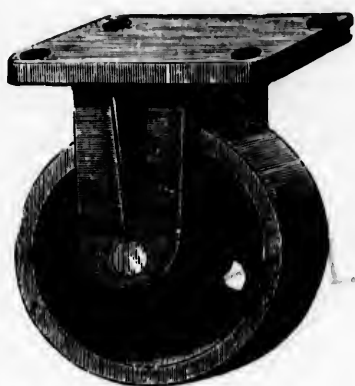

No. 1



No. 2

LEWIS &
LIMITED

No. 1— $3\frac{1}{2}$ inch, Single Wheel, Stationary.....				each	\$0.50
" 2— $3\frac{1}{2}$ " " " Swivel.....				"	0.62

GEM CASTERS



No. 237—Oblong Plate, Iron Wheel, Plate $1\frac{1}{2} \times 1\frac{1}{2}$, Wheel $1\frac{1}{2}$ inch.....				per set (4)	0.45
" 238— " " Lignum-vita Wheel, Plate $1\frac{1}{2} \times 1\frac{1}{2}$, Wheel $1\frac{1}{2}$ inch.....				"	0.50
" 437— " " Iron Wheel, Plate $2 \times 2\frac{1}{2}$, Wheel $1\frac{1}{2}$ inch.....				"	0.85
" 637— " " " " $2\frac{1}{2} \times 2\frac{1}{2}$, " 2 inch.....				"	1.15
" 837— " " " " Total Height $3\frac{1}{2}$ inch, Wheel $2\frac{1}{2}$ inch.....				"	2.70
" 937— " " " " $4\frac{1}{2}$ " " $3\frac{1}{2}$ ".....				"	3.00
" 1037— " " " " $5\frac{1}{2}$ " " 4 ".....				"	4.50

4) \$0.83
0.83
0.90
0.90
0.90
0.98
0.98

4) 0.68
0.68
0.68
1.05
1.05
1.05
1.05
1.13
1.13
1.13
1.50
2.25
2.63
2.63
6.75

GEM WIDE WHEEL CASTERS



No. 1—Plate $3\frac{1}{2}$ inch, Wheel $2\frac{1}{4}$ inch diam. x $1\frac{1}{4}$ inch Face, Height $2\frac{1}{2}$ inches.....per set (4) \$1.00
 " 2— " 3 " " $1\frac{1}{2}$ " x $1\frac{1}{4}$ " " $2\frac{1}{4}$ " "..... " 0.80

RUBBER WHEEL CASTERS



STATIONARY ROLLERS

3 inch, with Clark's Soft Rubber Wheels.....per set (4) 4.50

Size ...
 Nos ...
 Iron W
 Maple
 Porcela

No. 5—V
 " 3—C

BEDSTEAD CASTERS

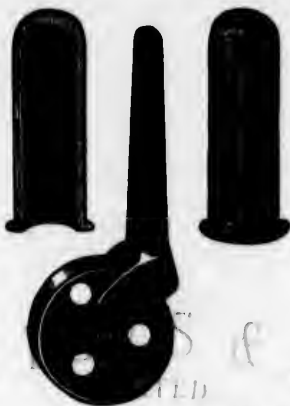

RICE & SONS

No. 2, 1 1/2 inch. Half size cut.

Size	1 1/2	1 1/2	2	2	2 inch.
Nos	1	2	1	2	
Iron Wheel	per set (4)	\$0.14	0.16	0.20	0.21
Maple "	"	0.14	0.16	0.20	0.21
Porcelain Wheel	"	0.16	0.18	0.22	0.24

Six sets in a package.

4) \$1.00
0.80

BEDSTEAD FASTENERS

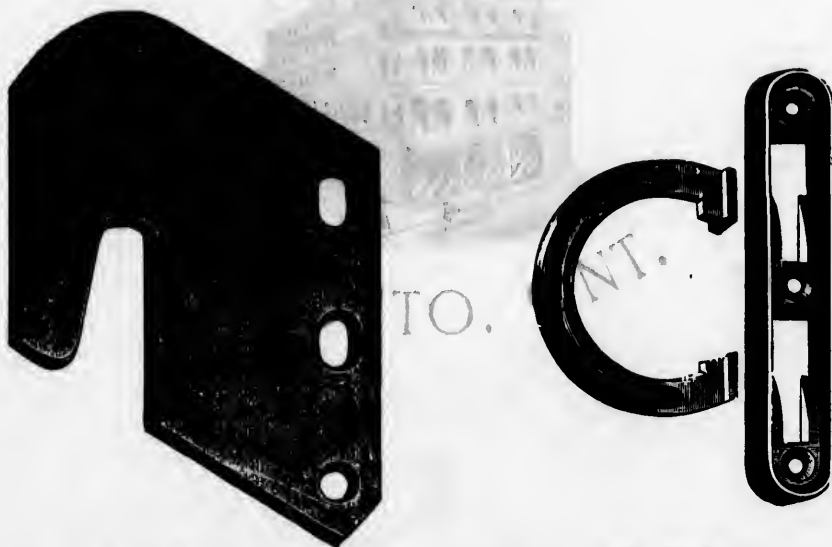

No. 5. Full size cut.

No. 3. Half size cut.

No. 5—Wrought Bedstead Fasteners, with 1 1/2 Post and 3/4 Rail Pins	per set (4)	\$0.15
" 3—Cast " " Horseshoe Pattern	"	0.15

No. 5, 100 sets, and No. 3, 50 sets, in a case.

4) 4.50

BRASS SCREW HOOKS

Full size cuts.



No. 19



No. 22

Brass Wire, Polished and Lacquered.

Nos.	19	20	21	22	23	24
Size	$\frac{1}{8}$	$\frac{1}{8}$	$\frac{1}{8}$	1	$1\frac{1}{2}$	$1\frac{1}{2}$ inch.
Per gross	\$0.90	1.00	1.20	1.40	1.75	2.10

One gross in a box.

BRASS CUP HOOKS



No. 0



No. 1

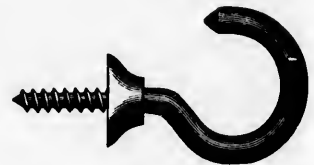

No. 3

Brass Wire, Polished and Lacquered.

Nos.	000	00	0	$0\frac{1}{2}$	1	2	3	4
Size	$\frac{1}{8}$	$\frac{1}{8}$	$\frac{1}{8}$	$\frac{1}{8}$	1	$1\frac{1}{2}$	$1\frac{1}{2}$	$1\frac{1}{2}$ inch.
Per gross	\$1.00	1.10	1.20	1.30	1.50	2.00	2.40	3.00

Half gross in a box.

BRASS SCREW RINGS



Nos.	37	36	35	34
Size of Ring	$\frac{1}{2}$	$\frac{1}{2}$	$\frac{1}{2}$	$\frac{1}{2}$ inch.
Per gross	\$1.25	1.40	1.50	1.90

One gross in a package.

DRAPERY HOOKS



No. 0321

No. 0321 -Brass-Plated per gross \$0.60

One gross in a package.

SQUARE CORNER SCREW HOOKS



2 inch.



1 3/4 inch.



1 1/2 inch.

BRIGHT IRON SQUARE CORNER SCREW HOOKS

Length.....	1 1/4	1 1/2	1 3/4	2	2 1/4	2 1/2	2 3/4 inch.
Per gross.....	\$0.40	0.53	0.67	0.80	1.00	1.40	1.80

One gross in a package.

HOOKS AND EYES



RIGHT OR LEFT HAND

Size.....			3/4	1 1/2	2	2 1/2	3 inch.
No. 50—Malleable Iron, Oval, Coppered.....		per gross	\$1.50	0.75	1.05	1.50	2.10
“ 61—Brass, Light, Double Convex.....		“	“	“	“	“	“
“ 60—“ Heavy “.....		“	“	2.10	2.85	“	“

One gross in a box. No. 50 Hooks have Malleable Cast Eyes.

BRASS CABIN DOOR HOOKS



No. 72—2 1/4 inch, Cast Brass, Polished and Lacquered.....	per doz.	\$2.25
“ 72-3 “ “ “ “.....	“	2.60
“ 72-3 1/2 “ “ “ “.....	“	3.00
“ 72-4 “ “ “ “.....	“	3.00
“ 773-2 1/2 “ “ “ Heavy, with Square Plates, Polished and Lacquered.....	“	4.15
“ 773-4 “ “ “ “.....	“	4.85
“ 773-5 “ “ “ “.....	“	5.40

Two dozen in a box.

24
1 1/2 inch.
2.10



4
1 1/2 inch.
3.00

34
1 inch.
1.90

gross \$0.00

WIRE GATE HOOKS AND EYES

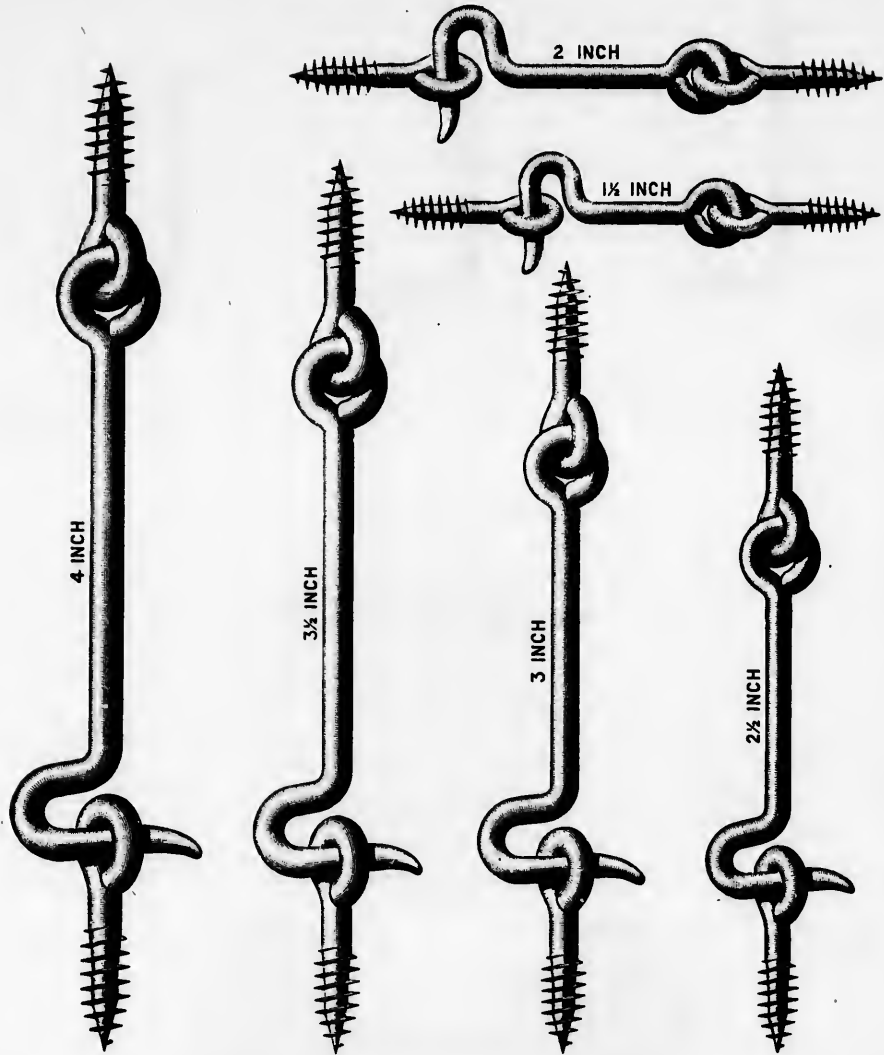

BRIGHT IRON GATE HOOKS AND EYES

Size.....	1½	2	2½	3	3½	4	4½	5	5½	6 inch.
Price..... per gross	\$1.40	1.70	2.10	2.30	2.80	3.35	4.00	4.80	5.65	6.50

BRASS GATE HOOKS AND EYES

Size.....	1½	2	2½	3	3½	4	4½	5	5½	6 inch.
Price..... per gross	\$2.70	3.60	4.75	6.55	8.35	10.45	12.70	15.20	16.00	16.80

1½ to 2½ inch one gross, larger sizes half gross in a box.

Nos.
Price

Nos.
Price

WIRE SCREW HOOKS



RICE LEWIS & SON
LIMITED



TORONTO, ONT.
SUIT M

BRIGHT IRON SCREW HOOKS

Nos.		2	3	4	5	6	7	8	9	10	11	12
Price	per gross	\$0.25	0.27	0.33	0.38	0.50	0.60	0.75	0.85	1.00	1.30	1.65

BRASS SCREW HOOKS

Nos.		2	3	4	5	6	7	8	9	10	11	12
Price	per gross	\$0.40	0.45	0.65	0.85	1.15	1.50	2.00	2.50	3.20	4.10	5.10

Sharp Points only kept in stock. Blunt Points to order.

One gross in a box.

6 inch.
6.50

6 inch.
16.80

WIRE SCREW HOOKS

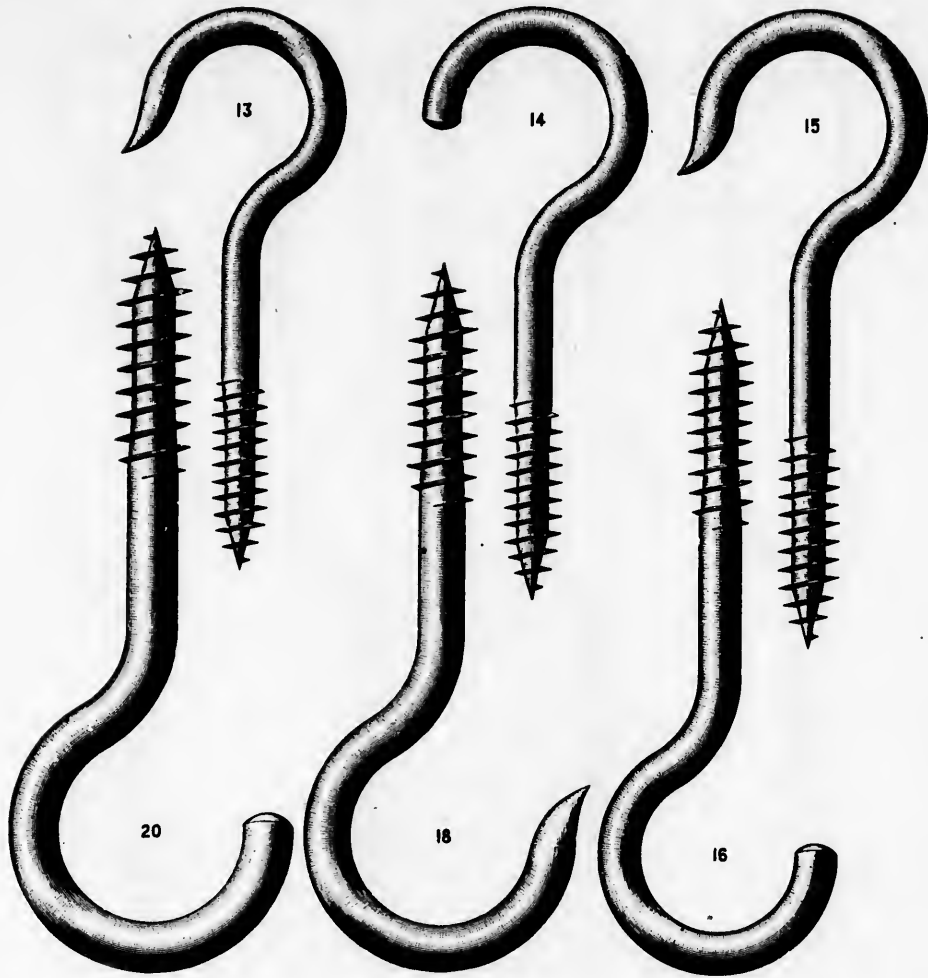

SUIT M

BRIGHT IRON SCREW HOOKS

Nos.....	13	14	15	16	18	20	
Price.....	per gross	\$2.00	2.40	2.90	3.50	4.25	5.70

BRASS SCREW HOOKS

Nos.....	13	14	15	16	18	20	
Price.....	per gross	\$6.30	7.40	8.80	10.00	13.40	16.00

Sharp Points only kept in stock. Blunt Points to order.

Half gross in a box.

Nos...
Price

Nos...
Price

Nos...
Price

Nos...
Price

WIRE SCREW EYES

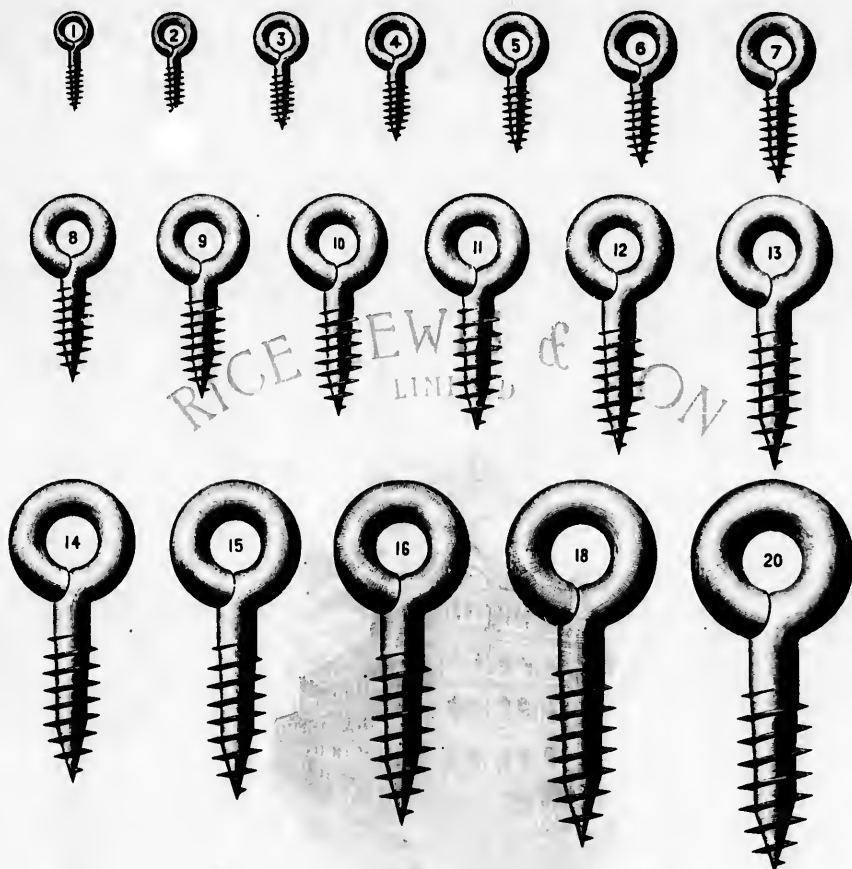

SUIT A

BRIGHT IRON SCREW EYES

Nos.....		1	2	3	4	5	6	7	8	9
Price.....	per gross	\$0.13	0.15	0.18	0.24	0.28	0.33	0.40	0.45	0.50
Nos.....		10	11	12	13	14	15	16	18	20
Price.....	per gross	\$0.60	0.70	0.90	1.10	1.27	1.45	1.80	2.30	3.15

BRASS SCREW EYES

Nos.....		1	2	3	4	5	6	7	8	9
Price.....	per gross	\$0.20	0.25	0.30	0.40	0.55	0.70	0.90	1.15	1.45
Nos.....		10	11	12	13	14	15	16	18	20
Price.....	per gross	\$1.85	2.25	2.75	3.30	4.00	4.55	5.40	7.20	9.30

Nos. 1 to 14 one gross in a box, Nos. 15 to 20 half gross.

20
5.70

20
16.00

WIRE SCREW EYES

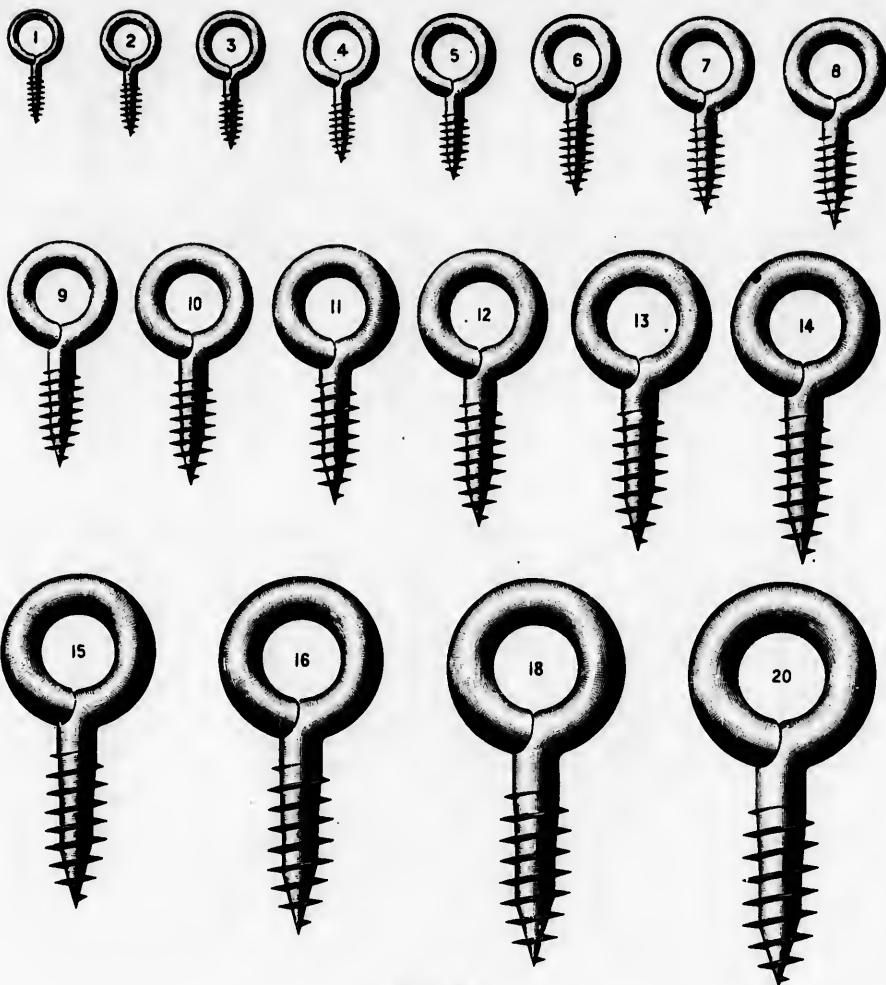

SUIT B

BRIGHT IRON SCREW EYES

Nos.....		1	2	3	4	5	6	7	8	9
Price.....	per gross	\$0.16	0.18	0.22	0.27	0.33	0.40	0.45	0.50	0.60
Nos.....		10	11	12	13	14	15	16	18	20
Price.....	per gross	\$0.75	0.85	1.00	1.20	1.40	1.70	2.00	2.60	3.75

BRASS SCREW EYES

Nos.....		1	2	3	4	5	6	7	8	9
Price.....	per gross	\$0.25	0.30	0.40	0.53	0.70	0.90	1.20	1.50	1.80
Nos.....		10	11	12	13	14	15	16	18	20
Price.....	per gross	\$2.20	2.80	3.50	4.20	5.00	5.60	6.40	8.40	11.00

Nos. 1 to 14 one gross in a box, Nos. 15 to 20 half gross.

Nos. .
Price.
Nos. .
Price.

Nos. .
Price.
Nos. .
Price.

Nos. .
Length
Price.

WIRE SCREW EYES

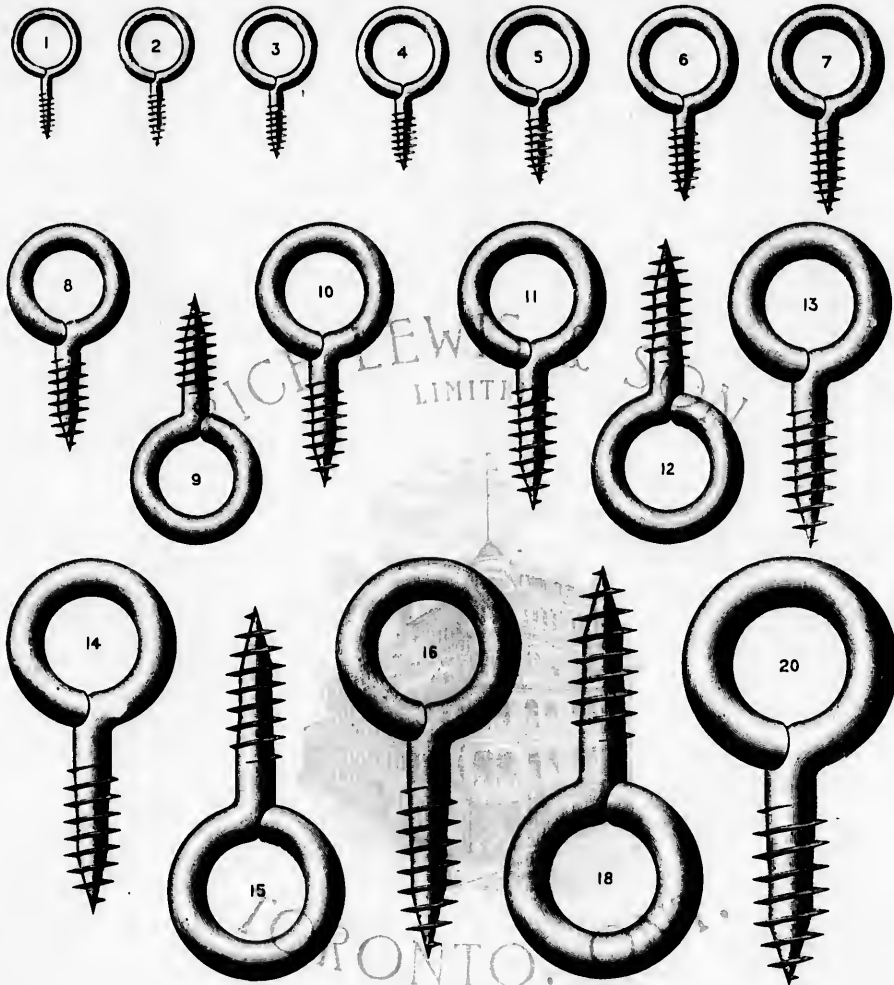

SUIT C

BRIGHT IRON SCREW EYES

Nos.	1	2	3	4	5	6	7	8	9
Price	per gross								
	\$0.18	0.20	0.24	0.30	0.37	0.45	0.53	0.60	0.70
Nos.	10	11	12	13	14	15	16	18	20
Price	per gross								
	\$0.80	1.00	1.20	1.40	1.00	1.00	2.30	2.00	4.00

BRASS SCREW EYES

Nos.	1	2	3	4	5	6	7	8	9
Price	per gross								
	\$0.30	0.40	0.50	0.60	0.80	1.00	1.40	1.80	2.30
Nos.	10	11	12	13	14	15	16	18	20
Price	per gross								
	\$2.90	3.50	4.20	5.00	5.80	6.60	7.40	9.40	12.00

STOVEPIPE SCREW EYES

Nos.		5	6	7	8
Length		1 1/2	2	2 1/2	3 inch.
Price		per gross			
		\$0.40	0.52	0.67	0.95

Nos. 1 to 14 one gross in a box, Nos. 15 to 20 half gross.

9
0.60
20
3.75

9
1.80
20
11.00

CHANDELIER HOOKS



No. 410



No. 220



No. 2

LAMP HOOKS

No. 2—1½ in., Japanned, . per gross \$2.00

No. 220—	4 inch, Amber Bronzed, Steel Screw	per doz.	\$1.05
" 220—	6 " " " " " "	"	1.25
" 410—	4 " " " " " "	"	0.85
" 410—	6 " " " " " "	"	0.95
" 410—	8 " " " " " "	"	1.10
" 410—	10 " " " " " "	"	1.25

CHANDELIER HOOKS



No. 240, 4 inch.



No. 270

Size	3	4	6	8	10	12 inch.
No. 240—Amber Bronzed, with Base, Steel Screw	\$0.00	1.20	1.45	1.80	2.15	2.50
" 270— " " " " " " " " " " " "	1.60	1.80

\$2.00

\$1.05
1.25
0.88
0.96
1.10
1.25

CHANDELIER HOOKS

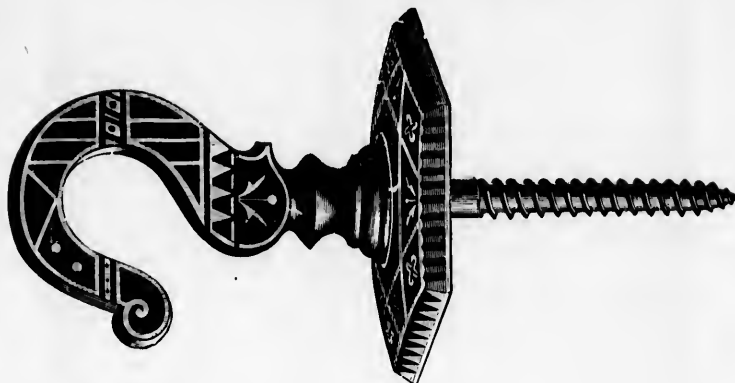

No. T450—2½ inch, Amber Bronzed, with Base.....	per doz.	\$0.75
" T450—4 " " " "	"	1.05

TO SCREW TO GAS PIPE



No. 260



No. 290, 1/2 inch. Full size cut.

No. 260—¾ inch, Amber Bronzed.....	per doz.	\$0.65
" 260—¾ " " "	"	0.75
" 290—¾ " " "	"	1.80
" 290—¾ " " "	"	1.90

No. 8

No. 25

No. 33

No. 116

BIRD CAGE HOOKS



One-third size cut.

No. 81—Amber Bronzed.....per doz. \$1.50



No. 25. Half size cut.

No. 25—Amber Bronzed, Steel Screw.....per doz. 0.80



No. 33. Half size cut.

No. 33—Amber Bronzed, Steel Screw.....per doz. 1.00



No. 116—Amber Bronzed, packed with Screws.....per doz. 2.30

z. \$0.75
1.05

z. \$0.05
0.75
1.80
1.90

BIRD CAGE HOOKS



No. 3024

9 inch, Amber Bronzed, to Swing.
Per dozen, \$2.00.

No. 3024

9 inch, Amber Bronzed, to Screw.
Per dozen, \$1.60.

BIRD CAGE SPRINGS



No. 10—Brass-Plated, per doz. \$0.35
" 20—With Chain, " 1.80

No. 3
" 25

No. 2
" 1
" 21

CLOTHES LINE HOOKS



No. 3



No. 25

No. 3—Japanned	per doz.	\$0.50
" 25—Galvanized	"	1.00



No. 2

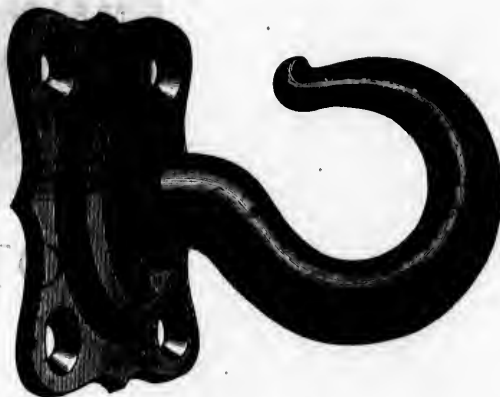

Nos. 1 and 21

No. 2—Japanned	per doz.	\$0.60
" 1— "	"	0.70
" 21—Galvanized	"	1.30

One dozen in a box.

HAMMOCK HOOKS

FIGOTT'S PATENT



No. 258. Full size cut.

No. 258—Tinned, with Plate.....per doz. \$2.30



No. 268. Full size cut.

No. 268—Tinned, with Wrought Screw.....per doz. 2.20

One dozen in a box.

The Hammock Hooks represented on this page are from new designs. They are so made that the weight holds the Hammock secure and fast. The Hammock is easily and quickly attached without fastening or tying and as easily and quickly removed.

z. \$1.80
and the

\$1.05
1.00

BAR MEAT HOOKS

TINNED IRON

Full size cuts.

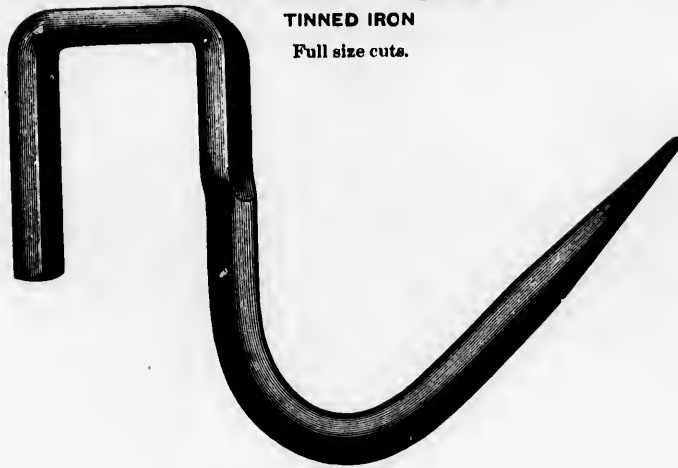

No. 89

No. 89	Tinned, Wrought Iron, for 1 inch Bar, $\frac{1}{4}$ inch Round Iron	per gross	\$23.00
" 90	" " " " $2\frac{1}{2}$ " $\frac{1}{8}$ " " "	"	32.00
" 92	" " " " $2\frac{1}{2}$ " $\frac{1}{8}$ " " "	"	79.00
" 100	" " " " $\frac{1}{2}$ " $\frac{1}{8}$ " " "	"	30.00

Nos. 89 and 90, one-sixth gross, No. 92, one-twelfth gross, No. 100, quarter gross in a box.

S MEAT HOOKS

TINNED IRON

No. 64	4 x $\frac{1}{2}$ inch, Wrought Iron	per gross	\$14.00
" 65	5 x $\frac{1}{4}$ " " " "	"	20.00
" 66	5 $\frac{1}{2}$ x $\frac{3}{8}$ " " " "	"	30.00

ENGLISH TINNED S HOOKS

Size	3 x $\frac{1}{8}$	3 x $\frac{3}{16}$	4 x $\frac{1}{4}$ inch.
Per gross	\$5.00	5.85	7.00

Nos. 64 and 65, half gross, and No. 66, quarter gross in a box.

Other sizes, 1 gross packages.

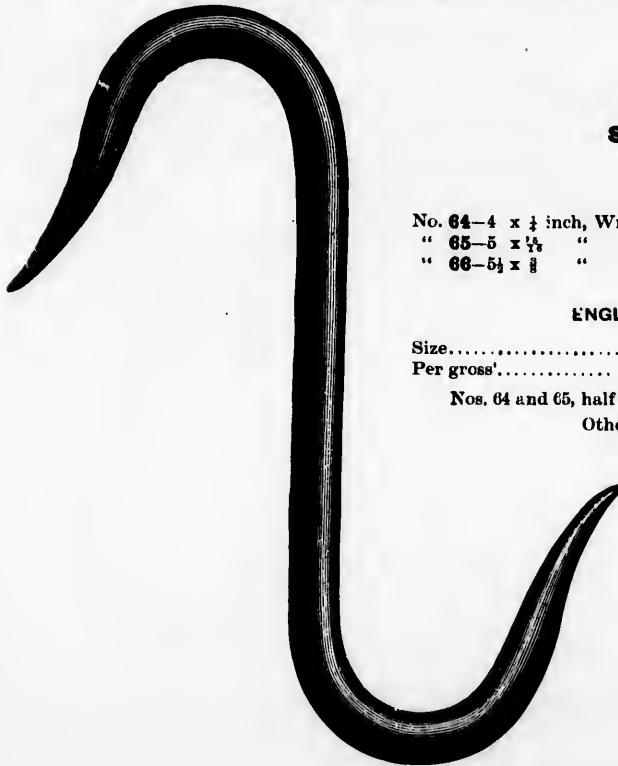

No. 12
" 13

No. 21
" 22
" 31
" 32

Size . . .
Per po . . .

CEILING HOOKS

Full size cuts.



No. 31



No. 3180. REVOLVING HOOKS

No. 31—Japanned Wire	per gross	\$ 5.00
" 3180—2 Hooks, Brass, Polished	"	14.40
" 3180—4 " " "	"	21.00



No. 135



No. 833P

No. 135 —Coppered	per gross	1.70
" 833P—Bronze Metal	per doz.	3.50

No. 5
" 5
" 5

No. 64

No. 3
" 57
" 57

WARDROBE HOOKS

Full size cuts.



No. 520—Japanned.....	per gross	\$1.20
" 521— ".....	"	1.50
" 522— ".....	"	1.90

No. 521, size between Nos. 520 and 522.

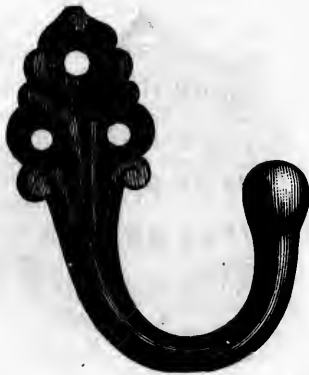

No. 640

No. 640—Cast Brass.....	per gross	22.00
-------------------------	-----------	-------



No. 356



No. 5717, 2 1/2 inch.

No. 356—Cast Bronze Metal.....	per gross	16.80
" 5717—2 1/2 Inch, Cast Brass, with China Knob.....	"	19.20
" 5717—3 " " " " ".....	"	21.60

\$ 5.00
14.40
21.00

1.70
3.50

WIRE HAT AND COAT HOOKS

Full size cuts.

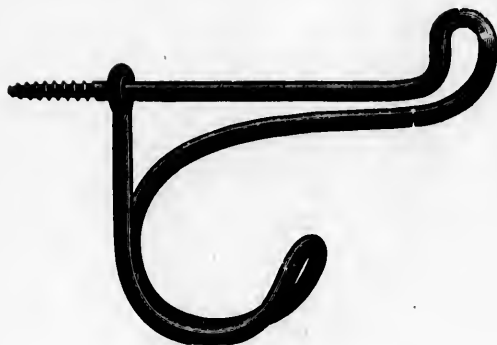

2 1/2 inch.

2 1/2 inch, Japanned	per gross	\$2.15
2 1/2 " Coppered	"	2.00
2 1/2 " Brass	"	5.20



3 inch.

3 inch, Japanned	per gross	2.55
3 " Coppered	"	2.40
3 " Brass	"	6.00

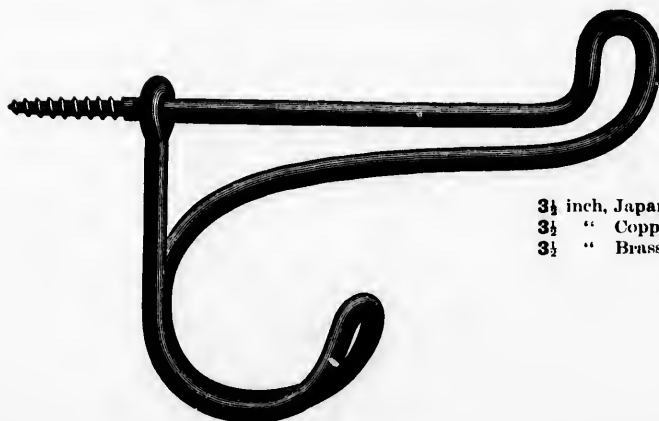

3 1/2 inch.

3 1/2 inch, Japanned	per gross	3.20
3 1/2 " Coppered	"	3.00
3 1/2 " Brass	"	8.75

Half gross in a box.



HAT AND COAT HOOKS



No. 3. Full size cut.

No. 1—3 in., Japanned, per gross \$1.40
 " 2—3½ " " " " 2.00
 " 3—4 " " " " 2.00

Quarter gross in a box.

CE LEWIS & SON
 LIMITED TORONTO, ONT.

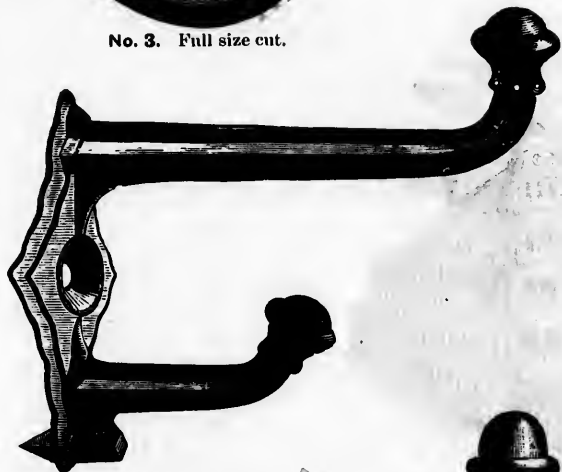

No. 4. Full size cut.

No. 4—Japanned..... per gross \$2.50
 " 4—Coppered..... " 2.50

Quarter gross in a box.

TORONTO, ONT.



No. 21. Full size cut.

SCHOOL HOUSE HOOKS

No. 21—3 in., Japanned, per gross \$3.00
 " 22—4 in., " " 3.80

Sixth gross in a box.

HAT AND COAT HOOKS

Full size cuts.

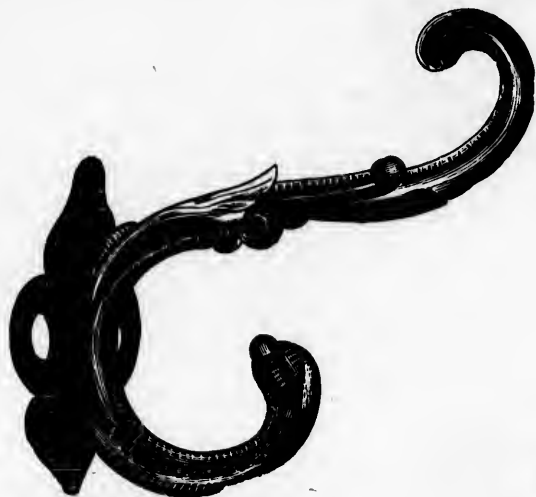

No. 8—Japanned.....per gross \$2.00

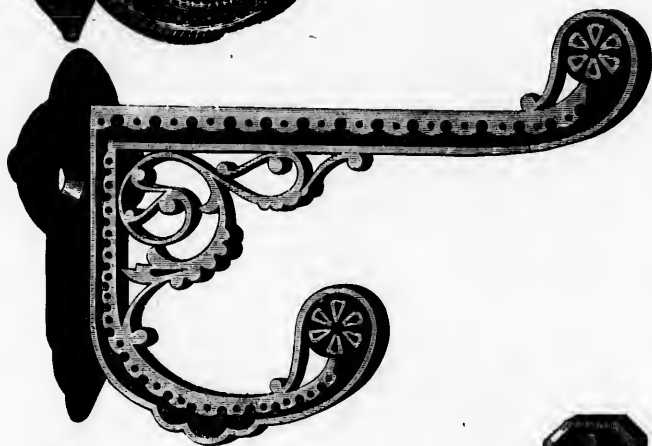

No. T404A—Amber Bronzed,
per gross..... 7.50



No. 1162

No. 1162—Bronze-Plated (10
Finish).per doz. 1.20

" 1160—Bronze Metal (3
Finish).per doz. 2.50

No. 2
" 26-

No. 14-
" 15-
" 16-

HARNESS HOOKS

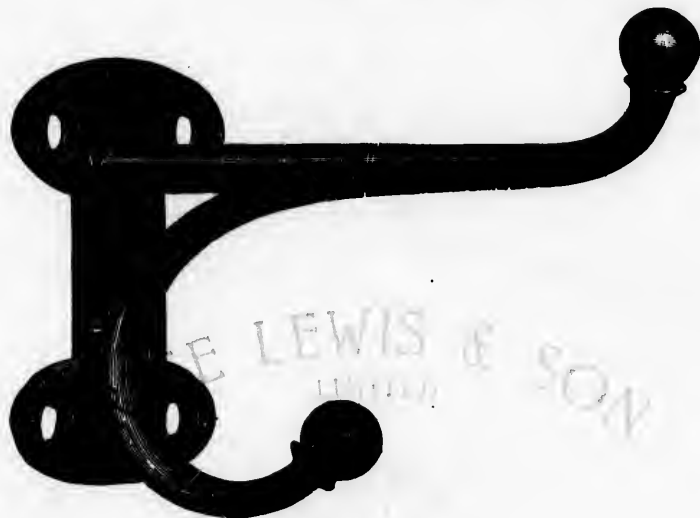

No. 2

No. 2—Japanned, 6 inch, Heavy	per doz.	\$1.10
" 26— " 6 " Extra Heavy	"	1.20



Nos. 14 to 16

No. 14—Japanned, 5½ inch	per doz.	1.30
" 15— " 7¼ "	"	1.40
" 16— " 9¼ "	"	1.60

HAT AND COAT HOOKS

Full size cuts.

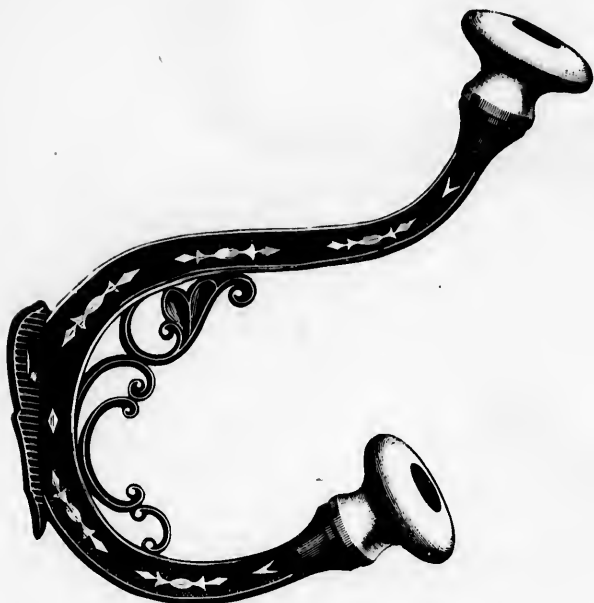

No. 392

No. 392—Amber Bronzed, with Porcelain Knob..... per doz. \$1.95



No. 200

No. 200	—6 inch, Plain Brass, Polished and Lacquered, with Porcelain Knob.....	per doz.	1.40
" 200 B	—6 " Ornamental Brass, Polished and Lacquered, with Porcelain Knob.....	"	1.50
" 6026	—6 " Plain " Heavy," " " " Brass ".....	"	3.70
" 6043	—6 " Ornamental " " " " " " Riveted Porcelain Knob.....	"	3.20
" 10067	—7 " Rope Pattern " " " " " " " " ".....	"	4.50

REGALIA OR TOWEL HOOKS

Full size cuts.



BRONZE METAL

No. 1239 $\frac{1}{2}$ —5 $\frac{1}{2}$ inch, Bent Ball Tip	per doz.	\$3.80
" 1239 $\frac{1}{2}$ —5 $\frac{1}{2}$ " Straight Ball Tip	"	3.80

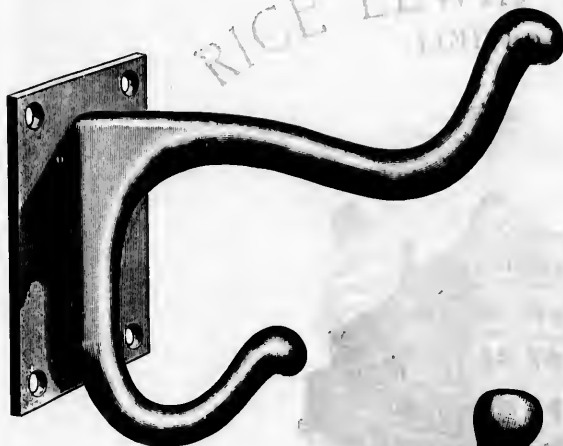

No. 01232 $\frac{1}{2}$

HAT AND COAT HOOKS

No. 01232 $\frac{1}{2}$ —Bronze Metal.....	per doz.	3.40
" 1034 $\frac{1}{2}$ —Bronze-Plated.....	"	0.75



No. 01238 $\frac{1}{2}$

No. 01238 $\frac{1}{2}$ —Cast Bronze Metal..	per doz.	4.85
--	----------	------

1.40
1.50
3.70
3.20
4.50

HAT AND COAT HOOKS

Full size cuts.

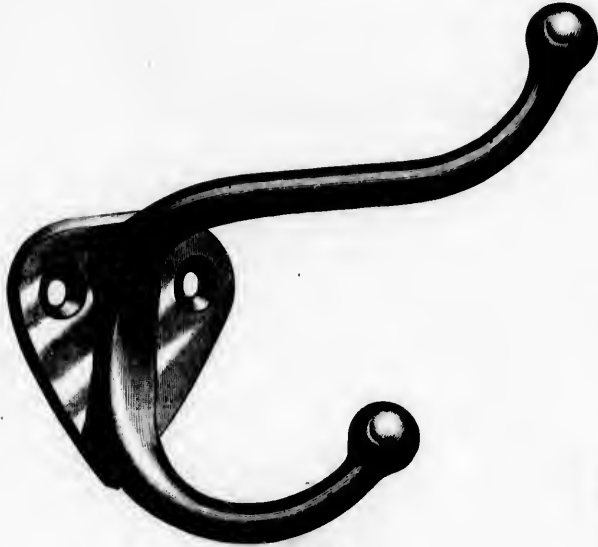

Nos. 360 and 2872

SOLID CAST BRONZE

No. 360 per doz. \$3.50

One dozen in a box.

WROUGHT STEEL, BRONZE-PLATED

No. 2872 per doz. \$1.00

Two dozen in a box.



No. 362

SOLID CAST BRONZE

No. 362 per doz. \$7.00

One dozen in a box.

HAT AND COAT HOOKS

Full size cut.



No. 1185

No. 1185—Antique, Copper Finishper doz. \$3.00

z. \$3.30

ATED

z. \$1.00

NZE

z. \$7.00

x.

HAT RACK HOOKS

Full size cuts.

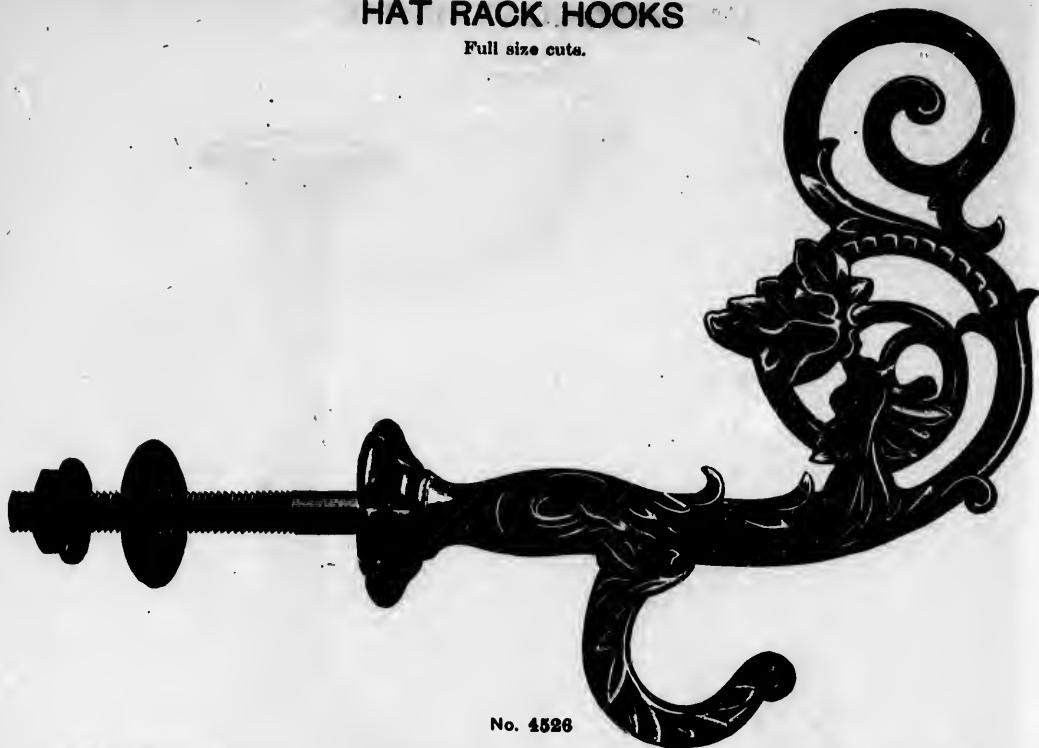

No. 4526

No. 4526—Cast Brass.....per doz. \$4.15



No. 4532

No. 4532—Cast Brass.....per doz. 10.50

HAT RACK HOOKS

Full size cuts.

No. 4603—Cast Brass per doz. \$4.15

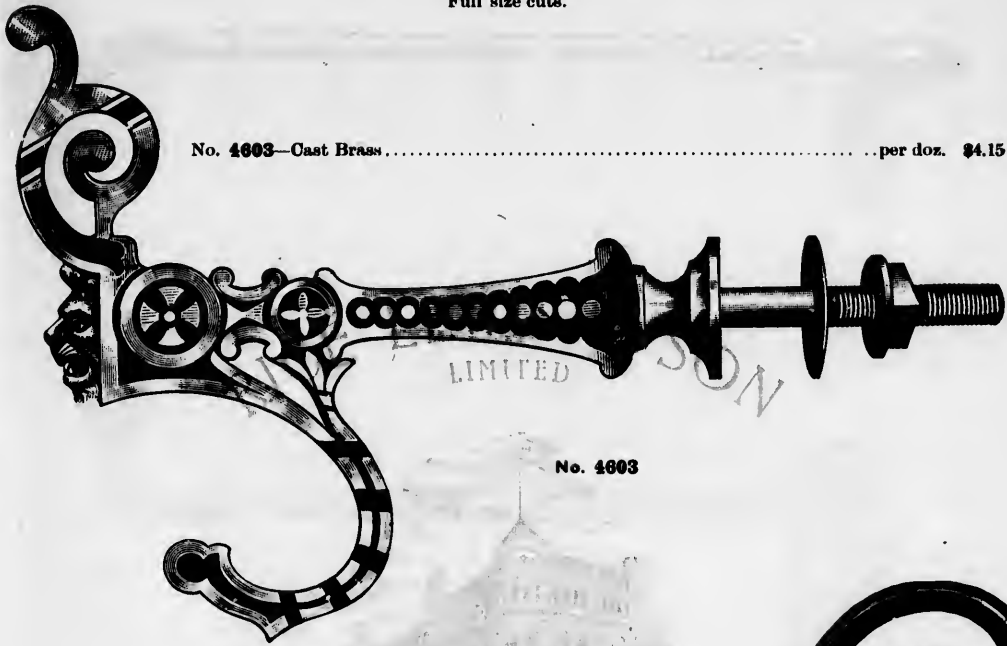

No. 4603

No. 4530—Cast Brass per doz. \$4.15



No. 4530

doz. \$4.15

doz. 10.50

TOWEL RACKS



No. 4629—12 inch Long, 1 1/4 inch Extension per doz. \$1.15

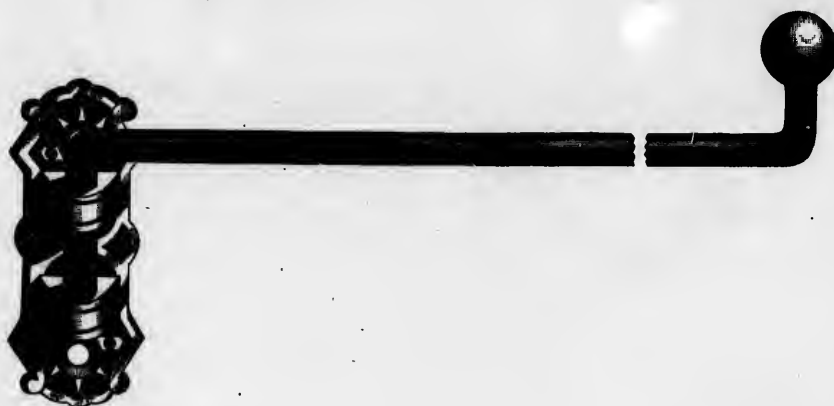

No. 4337—Length of Arm, 14 inches per doz. 2.10

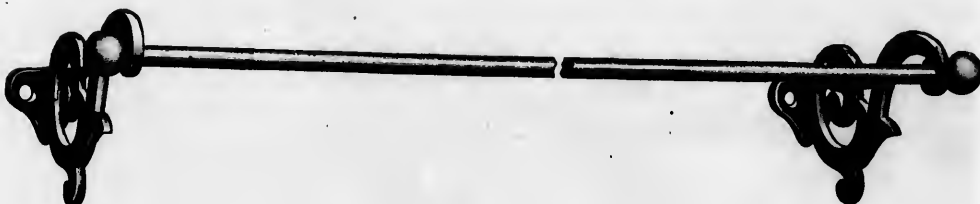

No. 5080—Single Arm, length outside of Brackets, 15 1/2 inches per doz. 6.00
 " 5078—Double " " " " 15 1/2 " " 10.50



9
Nos. . . .
Per 100

Nos. . . .
Per 100



805
Nos. . . .
Per 100

Nos. . . .
Per 100

Length
No. 210

Nos. . . .
No. 235

Length
No. 210

No. 9-2

UPHOLSTERERS' NAILS

BRASS HEAD

Full size cuts.

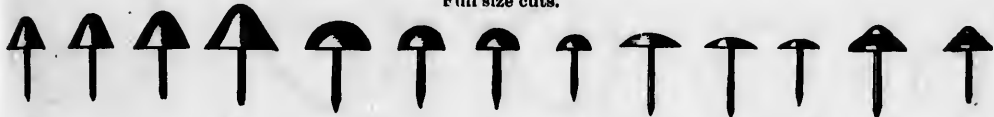

	6	5	4	3	10	11	12	12BB	42	43	43B	42F	43F
Nos.....	6	5	4	3	10	11	12	12BB	42	43	43B	42F	43F
Per 1000.....	\$0.92	1.03	1.42	1.90	1.40	1.10	0.92	1.2B	0.87	1.2BB	0.87	1.2BB	0.87
Nos.....	4 1/10	4 3/12	4 3/4	4 1/10	4 1/12	4 1/4	4.3B	4.2F	4.3F				
Per 1000.....	\$0.72	0.72	0.72	0.63	0.63	0.63	0.63	1.77	1.58				



	80B	528-0	530-0	528Y	528Y	528E	524E	528E	528E
Nos.....	80B	528-0	530-0	528Y	528Y	528E	524E	528E	528E
Per 1000.....	\$1.80	3.04	2.47	3.23	2.75	9.00	8.00	5.60	4.37

PORCELAIN HEAD



Nos. 4



137 1/2 Gilt

DRUGGET PINS



2163

DRAWING PINS



2331

Nos.....	4	137 1/2
Per 1000.....	\$1.00	0.80
Length.....	5/8	3/4 inch.
No. 2163.....	per gross \$0.70	0.80
Nos.....	2	4
No. 2331.....	per gross \$0.50	0.40

BRASS HEAD PICTURE NAILS



Length.....	1	1 1/4	1 1/2	1 3/4	2	2 1/4	2 1/2	3	3 1/2	4 inch.
No. 2160.....	per gross \$0.40	0.42	0.50	0.54	0.66	0.70	0.74	0.96	1.26	1.44

SLIDE HEAD PICTURE NAILS



No. 9

No. 9—2 1/2 inch, White Porcelain Centre, Plain Brass Rim.....	per gross \$2.70
--	------------------

BRASS CURTAIN RINGS



Nos.....	509	510	511	512	513	514	515	516	518	521	525	529
Size.....	1	1 1/4	1 1/2	1 3/4	2	2 1/4	2 1/2	2 3/4	3	3 1/4	3 1/2	3 3/4
Per gross	\$0.18	0.20	0.24	0.28	0.30	0.40	0.44	0.48	0.54	0.70	1.14	2.10



No. 4, 1/2 inch.

Size.....	3/8	1/2	5/8	3/4	
No. 4—Day's Patent, Brass Burnished.....	per gross	\$1.50	1.50	1.50	1.50

VESTIBULE BRACKETS



No. 14

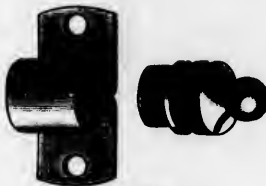

No. 22

Size.....	1/4	3/8	1/2	3/4	1
No. 14.....	per doz. pairs	\$0.85	1.00	2.00	3.00
" 22.....	" "	1.50	1.70	3.50	

BRASS POLE ENDS



No. 110

Size Tube or Pole.....	3/8	1/2	1	
No. 110.....	per doz. pairs	\$2.50	2.80	3.00

BRASS CASED ROD AND TUBING

See page 325.

BRACKET SHADE ROLLERS



Hartshorn, 1 1/2 inch.....	per gross	\$24.00
" 1 "	"	31.20
No. 1—Shade Roller Brackets, for 1 1/2 or 1 inch.....	"	3.50

TOILET CLIPPERS



No. 1661



No. 1662



No. 1724

No. 1661 — Boker's, Nickel-Plated.....	each	\$2.65
" 1662 — " ".....	"	2.40
" 1724-0 — " ".....	"	3.25
" 1724-1 — " ".....	"	2.85
Springs, for Boker's Clipper No. 1661.....	per doz.	0.45
" " " " " 1662.....	"	0.80

RICE LEWIS & SON
LIMITED



BROWN & SHARPE



WIDE AWAKE

No. 00—Brown & Sharpe, same as No. 0, but narrower.....	each	5.70
" 0 — " " to cut the hair very short, about equal to shaving.....	"	5.70
" 1 — " " " " one-eighth of an inch long.....	"	5.70
" 2 — " " " " one-quarter " ".....	"	6.65
" 3 — " " " " five-sixteenths " ".....	"	7.60
Wide Awake, to cut the hair one-eighth of an inch long.....	"	1.15
Springs, for Brown & Sharpe Clippers.....	per doz.	1.15

HORSE CLIPPERS



No. 1668

No. 1668—Boker's Tree Brand, with Leather Cover, Iron Ferrules.....	each	1.90
" 1669—"Gem," "Tin Plate" " ".....	"	1.35
" 1704—Boker's Tree Brand, Ball Bearing, with Leather Cover.....	"	2.40
Top or Bottom Plates, for Boker's Clipper No. 1668.....	"	0.75
" " " " " "Gem" " " 1669.....	"	0.60

CURRY COMBS

CLOSE BACK



No. 111

No. 111—Steel, 5 Bars, Close Backper doz. \$1.00

OPEN BACK

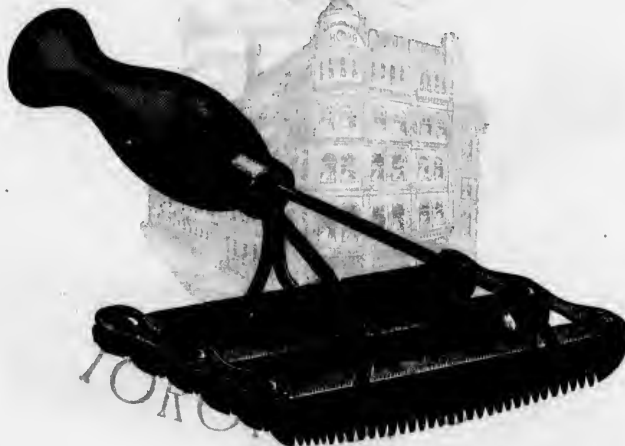

Nos. 121 to 125

No. 121—Steel, 6 Bars, Open Back.....	per doz.	1.45
" 123—Tinned, 6 " "	"	1.65
" 125—Brass, 6 " "	"	2.10

EIGHT BARS, OPEN BACK

No. 122—Steel, 8 Bars, Open Back.....	per doz.	1.80
" 124—Tinned, 8 " "	"	2.10
" 126—Brass, 8 " "	"	2.65

The Coppered Steel Wire Shanks are driven clear through the Handles and Riveted.

One dozen in a box.

each \$1.05
" 0.90
" 0.75

z. 16.20
3.60

z. 1.45

1.25
6.85
4.50

CURRY COMBS

OPEN BACK, WITH MANE COMB



No. 127

No. 127—Steel, 6 Bars, Close Back, with Mane Comb. per doz. \$2.10

CLOSE BACK



No. 147

No. 147—Steel, 6 Bars, Close Back per doz. 1.65

EIGHT BARS, CLOSE BACK

No. 148—Steel, 8 Bars, Close Back per doz. 2.00

The Coppered Steel Shanks are driven clear through the Handles and Riveted.
One dozen in a box.

No. 47

No. 48

N
through

No. 51

CURRY COMBS

CLOSE BACK



No. 47

No. 47—Steel, 6 Bars, Close Back per doz. \$2.10

EIGHT BARS, CLOSE BACK

No. 48—Steel, 8 Bars, Close Back per doz. 2.35

Nos. 47 and 48 have Steel Back and Steel Bars with strong Malleable Iron Brace Back, which is Riveted through Handle.

OPEN BACK



No. 51

No. 51—Solid Steel Back, Riveted through Handle, 6 Bars, Open Back per doz. 1.65

One dozen in a box.

z. \$2.10

1.65

2.00

CURRY COMBS

DOUBLE WOOD HANDLE

CIRCULAR SPRING STEEL



Nos. 33 to 37

No. 33—Steel, 6 Bars, Open Back.....per doz. \$2.00
 " 35—Tinned " " " " " " 2.90
 " 37—Brass " " " " " " 3.10
 Steel Bars, Malleable Iron Back.

No. 75
 No. 75—Circular Spring Steel.....per doz. \$2.22
 Strong Malleable Iron Shank, which is Riveted through Handle.

HORSE'S FRIEND CURRY COMB



FRONT VIEW



BACK VIEW

Horse's Friend Curry Combs.....per doz. \$2.75

GURRY COMB AND SCRAPER

CATTLE COMB



No. 3



No. 98

No. 3 —Ideal, Combined Curry Comb and Scraper, Japanned.....per doz. \$1.45
 " 98 —Cattle Comb, Steel, Straight Double Cut, Malleable Shank, Riveted through Handle. " 1.40
 " 038C— " " " 3 Bars, Closed Circular Back, Malleable Shank, " " 1.50

No. 1
 " 2
 " 3
 " 4
 " 5
 " 6
 " 7
 " 8
 " 9
 " 10
 " 11
 " 12
 " 13
 " 14
 " 15
 " 16
 " 17
 " 18
 " 19
 " 20
 " 21
 " 22
 " 23
 " 24
 " 25
 " 26
 " 27
 " 28
 " 29
 " 30

Size.....
 Each.....
 Size.....
 Back.....
 Size.....
 Back.....
 Size.....
 Each.....
 Size.....
 Each.....
 Size.....
 Each.....

SLEIGH BELLS



No. 2, ALASKA



No. 1, CENTENNIAL



No. 4, CENTENNIAL

No. 1—Back Strap, Plain Black Leather,	12	No. 2 Alaska Bells, Stamped, Nickeled.....	each	\$0.66
" 2— " " " " " "	30	" 2 " " " " " "	"	1.50
" 4— " " " " " "	12	" 1 Centennial Bells, Stamped, Nickeled.....	"	0.80
" 5— " " " Russet " " "	12	" 1 " " " " " " " " " " " " " " " "	"	0.80
" 6—Body " " Black " " "	24	" 1 " " " " " " " " " " " " " " " "	"	1.00
" 7— " " " Russet " " "	24	" 1 " " " " " " " " " " " " " " " "	"	1.00
" 8—Back " " Black " " "	10	" 2 " " " " " " " " " " " " " " " "	"	0.90
" 9—Body " " Blue " " "	30	" 2 " " " " " " " " " " " " " " " "	"	2.00
" 10— " " " Black " " "	24	" 2 " " " " " " " " " " " " " " " "	"	2.75
" 111—Back " Bound Russet " " "	10	" 4 " " " " " " " " " " " " " " " "	"	1.50
" 11— " " Plain Black " " "	10	" 4 " " " " " " " " " " " " " " " "	"	1.40



No. 1, DEXTER



No. 2, DEXTER

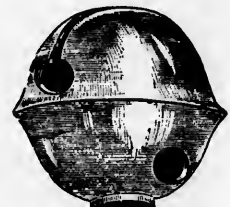

No. 3, CANUCK

No. 12—Back Strap, Plain Black Leather,	12	No. 1 Dexter Bells, Stamped, Nickeled.....	each	0.76
" 13—Body " " " " " "	30	" 1 " " " " " " " " " " " " " " " "	"	1.90
" 14— " " " " " " " " " " " "	40	" 1 " " " " " " " " " " " " " " " "	"	2.24
" 15— " " " " " " " " " " " "	50	" 1 " " " " " " " " " " " " " " " "	"	2.75
" 16— " " " Orange " " "	50	" 1 " " " " " " " " " " " " " " " "	"	2.75
" 17—Back " " Black " " "	12	" 2 " " " " " " " " " " " " " " " "	"	1.15
" 20— " " " " " " " " " " " "	12	" 3 Canuck " " " " " " " " " " " " " " " "	"	1.25
" 21— " " " Orange " " "	12	" 3 " " " " " " " " " " " " " " " "	"	1.45

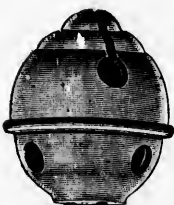

No. 1, C.O.C.



No. 2, C.O.C.



NEW BEVEL

No. 22—Body Strap, Plain Black Leather,	40	No. 1 C.O.C. Bells, Stamped, Nickeled.....	each	2.30
" 23— " " " " " " " " " " " "	60	" 1 " " " " " " " " " " " " " " " "	"	3.25
" 24— " " " " " " " " " " " "	70	" 1 " " " " " " " " " " " " " " " "	"	3.75
" 25— " " " Orange " " "	60	" 1 " " " " " " " " " " " " " " " "	"	3.25
" 26— " " " " " " " " " " " "	30	" 1 " " " " " " " " " " " " " " " "	"	2.30
" 27—Back " " Black " " "	12	" 2 " " " " " " " " " " " " " " " "	"	1.20
" 28— " " " Wine " " "	12	" 2 " " " " " " " " " " " " " " " "	"	1.20
" 29— " " " Black " " "	12	" 2 " " " " " " " " " " " " " " " "	"	1.50
" 30—Body " " Orange " " "	30	" 2 " " " " " " " " " " " " " " " "	"	3.50
" 31— " " " Black " " "	24	New Bevel " " " " " " " " " " " " " " " "	"	1.70
" 32— " " " " " " " " " " " "	40	" " " " " " " " " " " " " " " " "	"	2.50

SLEIGH BELLS



ACORN



DOME

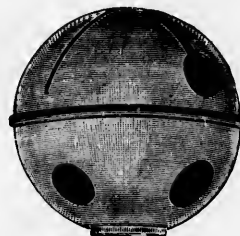

CARNIVAL

No. 35	—Back Strap, Plain Black Leather, 18 Acorn Bells, Cast, Nickeled	each	\$1.30
" 37	—Body " " " 50 " " " " " " " " " " " "	"	3.50
" 38	" " " " " 70 " " " " " " " " " " " "	"	4.80
" 43	" " " " Wine " 40 Dome " " " " " " " " " "	"	2.90
" 44	" " " " Black " 60 " " " " " " " " " " " "	"	4.20
" 45	" " " " " 10 Carnival Bells " " " " " " " " " " " "	"	1.00

RICE LEWIS & SON
LIMITED

YORK EYE AND TEAM BELLS

COLLAR AND SNAP SHANK BELLS



PEAR SHAPE



HEAVY TEAM



STRAPPED COLLAR



SNAP SHANK

Nos.....			10	12	14
York Eye, Pear Shape Bells, Cast, Nickel-Plated.....	per doz.	\$1.55	1.80	2.00	2.00
Nos.....			1	2	3
Heavy Team Bells, Cast, Polished Rim.....	per doz.	\$2.40	2.90	3.50	4.00
" " " Full Polished.....	"	2.70	3.20	3.80	4.00
" " " Nickel-Plated.....	"	2.90	3.50	4.00	4.00
No. 90—Strapped Collar Bells.....	per doz.				\$1.40
" 3—Snap Shank Bells.....	"				2.80

SHAFT GONGS



No. 57



No. 61

No. 56	—2 Nickel-Plated Steel Gongs on Iron Strap.....	per pair	0.40
" 57-3	" "	"	0.66
" 61-3	" "	"	1.20

SADDLE CHIMES

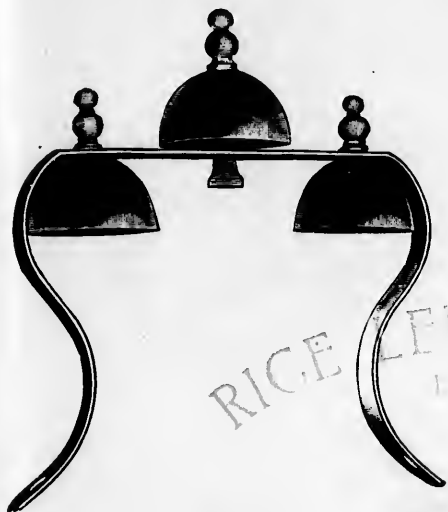

No. 77



No. 78

No. 77—Stamped Brass, Nickel-Plated.....each \$2.00
 " 78—Cast Brass Gongs, " " 1.75

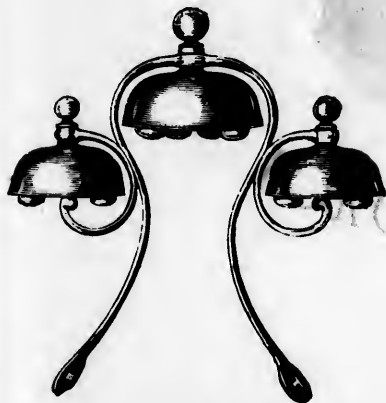

No. 80

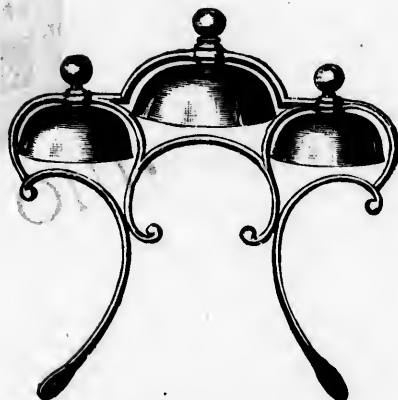

No. 82

No. 80—Cast Brass, Nickel-Plated.....each 3.80
 " 82— " " " " 4.50

HALTERS



No. 00



No. 1

No. 00—Web Halter, 12 Cord, Rope Chin Strap and Tie.....	per doz.	\$3.80
“ 1—Adjustable Web Halter, with Riveted Leather Chin Strap, Rope Tie.....	“	4.50



Nos. 3 and 4



Nos. 5 and 6

No. 3—Defiance Leather Halters, Black, 1 inch, Tinned Trimmings, Rope Tie.....	per doz.	6.50
“ 4— “ “ “ “ 1½ “ “ “ “	“	8.00
“ 5—Sensible “ “ “ “ 1 “ “ “ “	“	10.25
“ 6— “ “ “ “ 1½ “ “ “ “	“	12.00

SNAP AND RING ROPE TIES

Sisal, Diameter.....	¾	7/16	½	5/8 inch.
Per gross.....	\$14.50	16.00	17.50	20.00

No. 153—

“ 154—

“ 164—

“ 165—

“ 168—

No 216—B

DRIVING WHIPS

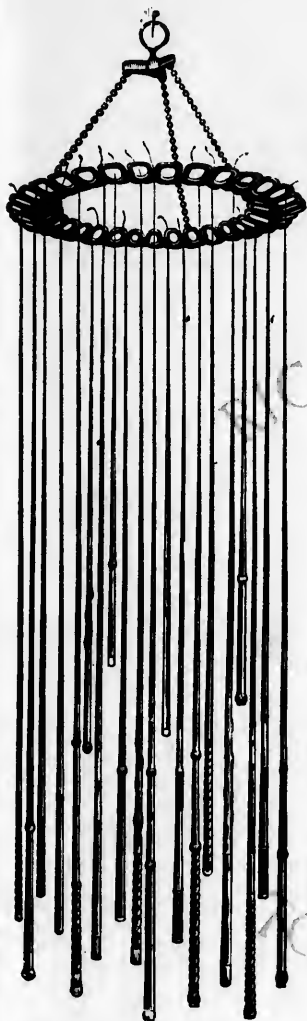

RATTAN, PLATTED THROUGHOUT

	Per doz.
No. 062—Black, Coppered Head, Loop Snap, 6 ft.....	\$1.35
" 065— " " " " Smooth Finish, 6 ft.....	1.90
" 71— " Rubber Cushioned Head, Loop Snap, Smooth Finish, 6 ft.....	2.25
" 86—Black, Japanned Cap, Loop Snap, Smooth Finish, 6 ft.....	2.05
" 87—Wine " " " " " " 6 ft.....	2.65
Nos. 86 and 87 have 4 Stitched Head Buttons.	
" 21—Black, Philadelphia Head and Snap, Smooth Finish, 6 ft....	3.00
" 33—Wine " " " " " " 6 ".....	3.00
" 66—Black " " " " " " 6 ".....	3.00
No. 33 has 2 Celluloid Mounts; No. 66, 2 Brass and Colored Mounted Buttons.	
" 92—Assorted Colors, Black, Wine and Amber, Fancy 1½ inch Coppered Head and Mount, Philadelphia Snap, 6 ft.....	3.75
" 18—Black, Russet Leather Handle, Japanned Cap, 1½ inch Chased Nickered Mounting, 4 Stitched Head Button, Philadelphia Snap, 6 ft.....	4.50
" 24—Wine, Loaded Butt Handle, one 3½ inch Mounting, Philadelphia Snap, 6 ft.....	4.90
" 686—Harvester Whip, Black, Nickered Head and Mount, Loop Snap, 10½ ft.....	6.00

RAWHIDE

No. 141—Black, Solid Rawhide Centre, Metal Lined, Rubber Cushioned Cap, 2 Loomis Buttons, Philadelphia Snap, 6 ft.....	5.25
" 162—Black, Solid Rawhide from Tip to Butt, 2 Square Buttons, Philadelphia Snap, 6 ft.....	7.15
" 143—"Keystone," Black, Solid Rawhide Centre, Waterproof Lined, Rubber Cushioned Cap, 2 Loomis Buttons, Philadelphia Snap, 6 ft.....	9.00
" 155—"Famous," Black, Solid Rawhide Centre, Linen and Buck Lined Rubber Cap, 2 Buttons, Philadelphia Snap, 6 ft..	9.75
" 157—"La Vera Derma," Black, Solid Rawhide from Tip to Butt, Double Cover and Waterproof Underlining entire length, Loomis Buttons, Philadelphia Snap, 6 ft.....	10.50
" 158—"Apex," Black, Solid Rawhide Centre, Horsehair Woven, Waterproof Underlining, Rubber Cushioned Head and Mountings, Philadelphia Snap, 6 ft.....	12.00
" 152—"True Grip," Black, Solid Rawhide Centre, Double Cover and Waterproof Underlining entire length, Rubber Cap, Fine Hand-Worked Buttons, Philadelphia Snap, 6½ ft...	13.50
No. 153—"True Grip," Wine Color, other particulars same as No. 152.....	13.50
" 154—"Cyclorama," Black, Solid Rawhide Centre two-thirds length, Buck Lined and Double Covered entire length, Rubber Cap, Hand-Worked Buttons, Philadelphia Snap, 6 ft.....	15.00
" 164—"Vulcanite," Wine, Solid Rawhide Centre to Handle, Genuine Rubber Underlining Vulcanized on the Stalk, making it perfectly Waterproof, Rubber Cushioned Cap, Loomis Buttons, Philadelphia Snap, 6 ft.....	18.00
" 165—"Vulcanite," Black, other particulars same as No. 164.....	18.00
" 168— " Linen " " " " " ".....	18.00

WHALEBONE

No. 216—Black, Heavy two-thirds Bone, Double Covered, Waterproof, Rubber Cap, 3 English Buttons, Philadelphia Snap, 6 ft.....	22.50
---	-------

er doz. \$3.80
" 4.50

r doz. 6.50
" 8.00
" 10.25
" 12.00

5/8 inch.
20.00

WHIP RACKS



No. 1



No. 2



No. 3

No. 1—Handy Whip Racks.....		per doz.	\$3.00
“ 2—Straight, “			2.20
“ 3—Circular “	16½ inch Diam, holds 64 Whips, Japanned, without Chains.....		11.25

WHIP SOCKETS



No. 1



No. 265



No. 2

No. 1—For Wood Dash.....		per doz.	\$ 6.30
“ 2—For Leather Dash.....			12.00
“ 265.....			29.70

No. 1—P
“ 2—

Cast Iron,

HORSE POKES



CLIMAX



DICTATOR



CHAMPION

RICE LEWIS & SON
LIMITED

Climax.....	per doz.	\$3.60
Dictator.....	"	3.40
Champion.....	"	3.40
No. 2—Pearson's Patent.....	"	7.90

No. 2, PEARSON'S PATENT

TORONTO, ONT.

HITCHING POSTS

No. 1—Painted, with Ring, same as cut.....	each	\$7.50
" 2— " Ventilator, Round Cap.....	"	7.50

HORSE TIE WEIGHTS

Cast Iron, with Wrought Iron Loop, 12 to 20 lbs.....	per lb.	0.06
--	---------	------



No. 1

STABLE FIXTURES

CAST IRON STALL PARTITION

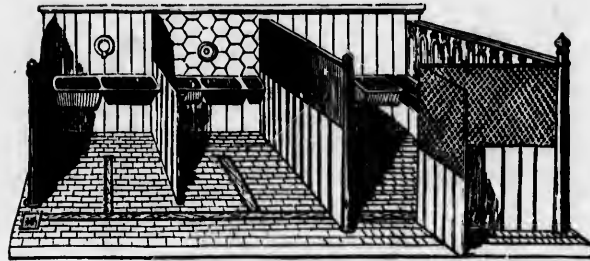

Regular size, 7 feet long x 2 feet 4 inches high. Box Stall work to match, 2 feet 4 inches high, and in any length ordered.

CAST IRON HAY RACKS

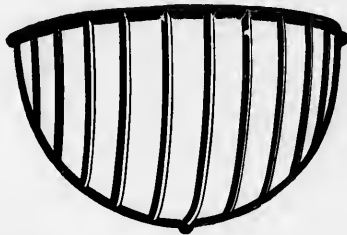

No. 6

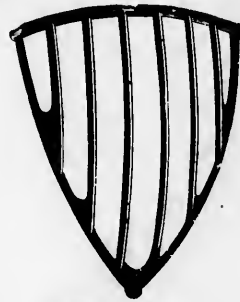

Nos. 10 to 12

No. 6—Half Circle for Side of Stall, Size 40 x 17 inch, Weight about 50 lbs.....	each	\$6.30
" 10—Made to Fit Corner of Stall, Size 30 x 24 " " " 27 "	"	1.75
" 11— " " " " " 30 x 24 " " " 30 "	"	2.00
" 12— " " " " " 30 x 24 " " " 35 "	"	2.25

CORNER MANGER OR FEED BOXES

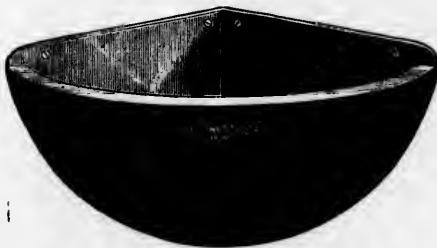

No. 1



No. 2

No. 1—With Food Guard, 17 x 17 x 10 inches	each	\$1.50
" 2—"Slow Feed," 17 x 17 x 6 inches.....	"	2.50

The "Slow Feed" has seven small Cells or Pockets, each Cell holding about one pint, absolutely prevents waste and also prevents a greedy horse eating the grain too fast.

STABLE CESSPOOLS AND GRATES



No. 15

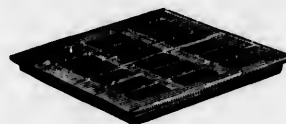

No. 16

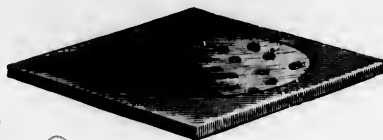

No. 17

RICE LEWIS & SON
LIMITED

No. 15—Cesspool, size 16 x 16 inch, Heavy Double Grate.....	each	\$3.50
" 16— " Grate, size 11 x 11 inch.....	"	1.20
" 17— " " " 4 to 12 inches square.....	per lb.	0.10

CAST IRON STABLE GUTTERS

Made in Sections 3 feet long, 7 inches wide, Movable Cover..... per ft. 1.80

BRACKETS

Saddle	each	\$1.40
Bridle	"	0.40
Blanket	"	0.90

TORONTO, ONT.

STEEL CARRIAGE JACKS

Strong, Light and Compact, operated by Powerful Compound Levers.
Adjustment rapid and convenient, with wide range in height.

No. 1—Lifts to 900 lbs.....	each	\$1.40
" 2— " 1800 "	"	2.10
" 3— " 4000 "	"	4.90



HITCHING RINGS



Nos. 15 to 17

No. 15—2½ inch, Wrought Iron, Plain.....	per doz.	\$0.90
" 16—2½ " " " Japanned.....	"	1.30
" 17—2½ " " " Galvanized.....	"	1.50



No. 36



Nos. 45 and 47

No. 36—2½ inch, Wrought Ring and Swivel, Iron Plate, Japanned.....	per doz.	\$1.05
" 45—2½ " " " and Plate, Japanned.....	"	1.05
" 47—2½ " " " " Galvanized.....	"	1.50

One dozen in a box.

HITCHING RINGS AND STAPLES

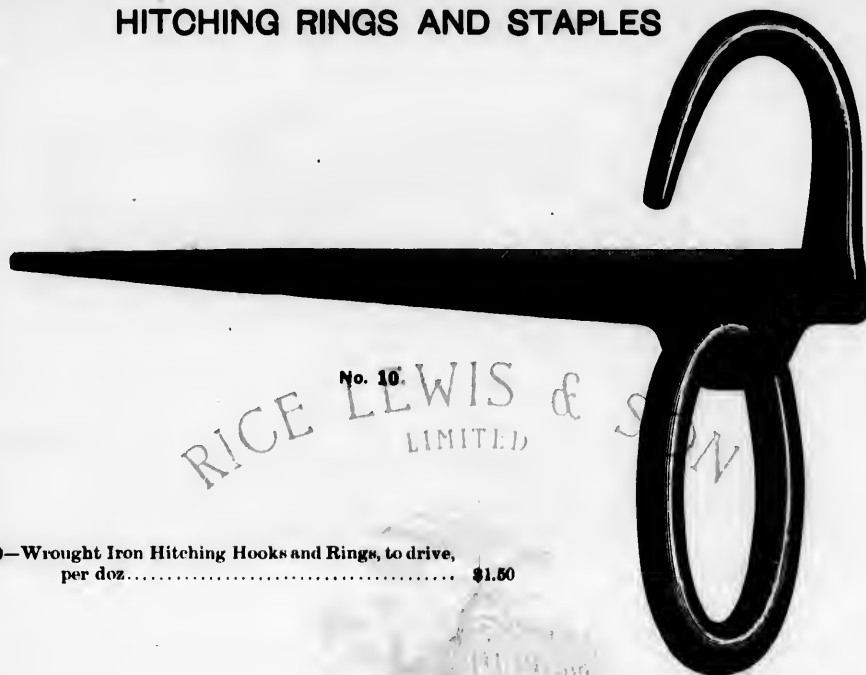

No. 10.
RICE LEWIS & SONS
LIMITED

No. 10—Wrought Iron Hitching Hooks and Rings, to drive,
per doz..... \$1.50

RINGS AND STAPLES

HALTER RINGS



No. 55

No. 55—2½ inch, Wrought Trap Door or Hitching Rings and Staples..... per gross \$3.75

MALLEABLE HALTER RINGS

Size.....	5/8	3/4	7/8	1	1¼	1½	1½	1¾	2 inch.
Japanned..... per gross	\$0.52	0.56	0.64	0.80	0.90	1.52	1.62	1.96	2.22
XC..... "	0.58	0.60	0.70	0.90	1.30	1.80	1.90	2.20	2.74

WROUGHT PACK RINGS

Size.....	5/16 x 2	3/4	2½	2¾	3	3¼	3½	3¾	4 inch.
Japanned..... per gross	\$2.50	3.00	3.20	4.00	4.50	5.00	5.50	6.00	6.50

\$0.90
1.30
1.50

\$1.05
1.05
1.50

HARNESS SNAPS



No. 23

GERMAN PATTERN

Nos.....	20 1/4	22	23	25	26	27	28
Size of Eye.....	1/2	1	1	1 1/2	1 1/2	1 3/4	2 inch.
Bronzed.....per gross	\$2.00	2.40	2.40	4.20	5.50	7.00	8.00



No. 60



No. 63

Nos.....	60	61	62	63
Size of Eye.....	1/2	1	1	1 3/4 inch.
Bronzed.....per gross	\$2.00	2.40	3.20	4.00



No. 2

No. 2—Loop Eye, Japanned, 1/2 inch.....	per gross	\$7.25
" 4— " " 1 ".....	"	8.75
" 7— " " 1 1/2 ".....	"	15.50

ROUND EYE

No. 20—Round Eye, Japanned, 1/2 inch Round Eye.....	per gross	12.00
---	-----------	-------

BIT SNAPS



No. 15

No. 14—Coleman's Patent Bit Snaps, Bronzed.....	per gross	4.65
" 15—XC Bit Snaps.....	"	4.15

HARNESS SNAPS

TINNED



No. 32, GEM



No. 4, HUBBARD'S

Size		$\frac{3}{8}$	$\frac{1}{2}$	$\frac{3}{4}$	1	$1\frac{1}{2}$	$1\frac{3}{4}$	$1\frac{1}{2}$ inch.
No. 32—XC Plate.....	per gross	\$6.00	6.00	8.25	9.00	10.50		
" 4— "		7.20	7.20		



No. 12



No. 12, OPEN EYE

Size		$\frac{3}{8}$ B	$\frac{1}{2}$	$\frac{5}{8}$	$\frac{3}{4}$	1	$1\frac{1}{4}$	$1\frac{1}{2}$	$1\frac{3}{4}$ inch.
No. 12—Bolt Snaps, XC	per gross			\$2.70	2.80	4.80	5.40	6.20	
" 12— " " Round Eye, Closed		\$3.20	3.30	
" 12— " " " Open		\$4.20	
" 13— " " " Heavy		9.40	



No. 10



SEE SPRING GUARDS.

No. 55

Size		$\frac{1}{2}$	$\frac{5}{8}$	$\frac{3}{4}$	$\frac{7}{8}$	1	$1\frac{1}{4}$	$1\frac{1}{2}$	$1\frac{3}{4}$	2 inch.
No. 10—Lock Snaps, XC	per gross					\$7.20	9.40	10.00	12.00
" 55— " Triumph, "						\$3.18	3.38	5.78	6.40	7.08
" 17— " Premier, "						2.68	2.78	4.58	5.42	6.65
" 18— " " Round Eye		\$2.47	2.47	2.57

BREAST STRAP ROLLER SNAPS



No. 19



No. 42

Size		$1\frac{1}{2}$	$1\frac{3}{4}$ inch.
No. 19—Breast Strap Roller Snaps, XC	per doz.	\$2.00	2.18
" 42— " " "		2.00	2.18

BAG AND SWIVEL SNAPS



No. 5961

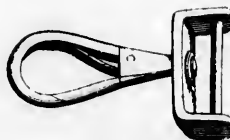

No. 5628

Style of Nos. 5627 and 5626

Length over all.....	1	1½	1¾	1¾	1¾	2 inch.
No. 5961.....	per doz.	\$1.20	1.20	1.20	1.40	1.60
Nos.....				5628	5627	5626
For Strap, width.....				¾	¾	1 inch.
Per dozen.....				\$2.50	2.80	3.70

DOUBLE SWIVELS

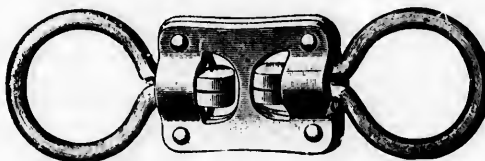

Two Ring or Rope Swivels, ¾ inch.....per gross \$6.20

COCK EYES



No. 10



No. 11

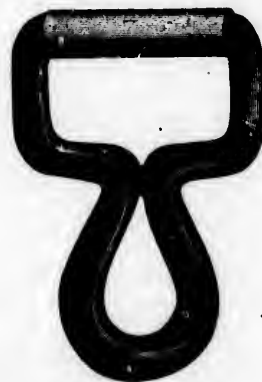

No. 12

Size.....	1¼	1½	1¾	2 inch.
No. 10—Little Giant Malleable Screw Cock Eye, with Rollers.....	per single doz.	\$0.40	0.45	0.50
" 11—Plain Malleable Screw Cock Eye, with Rollers.....	" "	0.38	0.40	0.45
" 12—Wrought Steel Cock Eyes.....	" "	0.38	0.40	0.45

BULL SNAPS AND RINGS



No. 500. Full size cut.



Showing the Bull Snap Attached to Handle

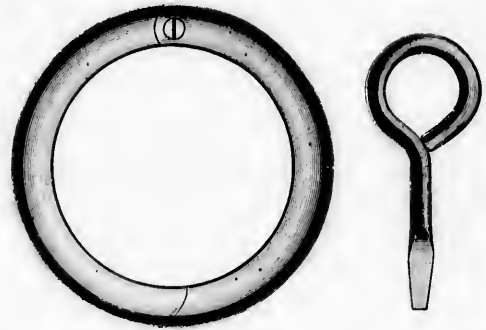

No. 11—Steel, 2½ inch diameter	per doz.	\$1.50
" 12— " 3 " "	"	1.05
" 20—Copper, 2 " "	"	1.75
" 21— " 2½ " "	"	1.90
" 22— " 3 " "	"	2.20

OX BALLS



No. 13



No. 14

No. 13—Cast Brass	per gross	0.75
" 14— " "	"	8.25

CATTLE LEADERS

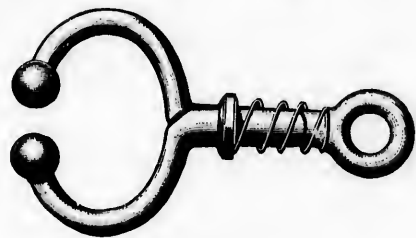

No. 52. Half size cut.

No. 51—Cattle Leaders, Bright, with Brass Wire Spring, length over all 4½ inches	per doz.	0.80
" 52— " " " " "	"	0.05
" 500—Bull Snaps, with 3 feet Chain and Ring on End, and 3 Screw Eyes, without Handle	"	5.10

Trade M
No. on
Approx
Price p
"

STEEL WIRE CHAIN

BROWN'S PATENT



No. 2



No. 1



No. 0



No. 2-0



No. 3-0



No. 4-0



No. 5-0

Trade No.	7-0	6-0	5-0	4-0	3-0	2-0	0	1	2	4
No. on Wire Gauge	4	5	6	7	8	9	10	11	12	14
Approximate Length per lb.	1.90	2½	2.00	3½	4½	5	6½	8½	10½	16½ ft.
" Breaking Strain, lbs.	3200	2400	2100	2000	1800	1500	1200	1000	800	450
Price per 100 feet, Bright	\$12.50	10.50	9.50	8.85	7.75	6.75	6.00	5.25	4.65	3.50
" " Galvanized	21.40	17.75	15.30	14.05	11.75	10.25	8.75	7.25	6.35	5.00

Put up 100 feet in a box, or in kegs of about 100 lbs.



10z. \$1.50
1.05
1.75
1.90
2.20



1½
ROSS 0.75
8.25



z. 0.80
0.95
5.10

AMERICAN CHAINS

Full size cuts.



Nos. 7



6



5



4



3



2



Nos. 1



0



2-0



3-0



4-0

Nos. 1	0	2-0	3-0	4-0	5-0	6-0	7-0
Noe.....	4-0	3-0	2-0	0	1	2	3
Per 100 feet.....	\$8.50	7.30	6.15	5.50	4.75	4.10	3.90
						3.80	3.70
							3.60
							3.60
							3.60

One hundred feet in a box.

JACK CHAIN

SINGLE LINK



DOUBLE LINK



Nos	7	8	9	10	11	12	13	14	15	16	17	18	19	20	21	22
Single, Steel	per doz. yds.	\$0.90	0.75	0.54	0.49	0.43	0.38	0.34	0.30	0.28	0.25	0.24	0.23	0.22	0.21	0.20
Double, "	"	1.20	0.96	0.83	0.75	0.60	0.53	0.47	0.42	0.38	0.33	0.30	0.28	0.25	0.23	0.21
Single, Brass	"	5.25	4.25	3.50	2.55	2.05	1.70	1.35	1.00	0.86	0.82	0.60	0.54	0.50	0.45	0.40
Double, "	"	4.25	3.45	3.00	2.15	1.90	1.50	1.20	1.00	0.75	0.65	0.62	0.60	0.60	0.60	0.60

One dozen yards in a box.

BRASS SAFETY CHAIN

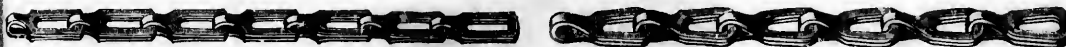

No. 2-0, REGULAR

No. 2-0, PLUMBERS'

Nos	3	2	1	1-0	2-0	3-0	4-0
Regular, Brass	per doz. yards	\$3.15	2.30	1.85	1.50	1.25	1.15
Plumbers', "	"	2.40	1.85	1.50	1.25	1.15	1.05
" Nickel-Plated	"	2.40	1.95	1.60	1.35	1.25	1.15
Regular, Brass	per 100 feet	9.00	6.40	5.20	4.30	3.60	3.30

One dozen yards in a box; 100 feet on a reel.

GERMAN COIL CHAIN

Full size cuts.

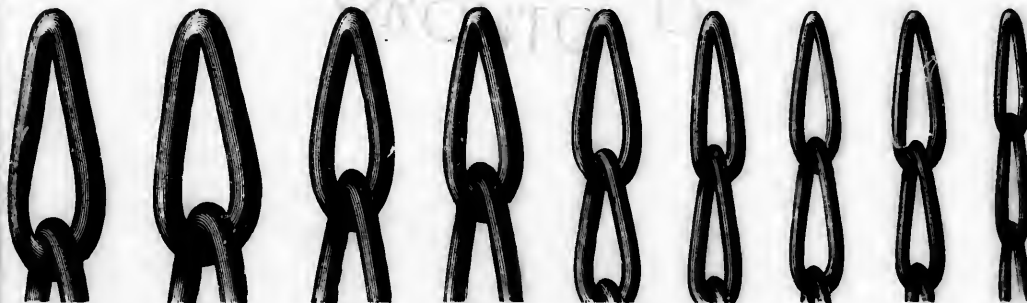

Nos	3-0	2-0	0	1	2	3	4	5	6
Per 100 feet	\$4.65	4.15	3.85	3.45	3.25	2.95	2.95	2.95	2.95

One hundred feet in a package.

GERMAN HALTER AND DOG CHAINS



Nos.....		3-0	2-0	0	1	2	3	4	5	6	7	8
4½ feet.....	per doz.	\$2.75	2.55	2.40	2.10	1.95	1.85	1.80	1.70	1.70	1.70	1.70
6 ".....	"	3.15	2.90	2.20	2.20

For cuts showing sizes of Chain, see page 700.

AMERICAN HALTER AND DOG CHAINS

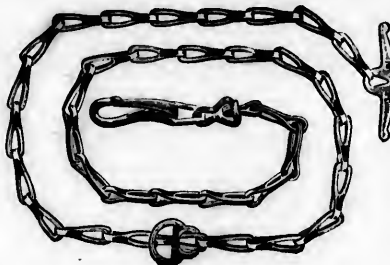

Nos.....		3-0	2-0	0	1	2	3	4	5	6	7
4½ feet.....	per doz.	\$4.85	4.10	3.50	3.00	2.65	2.40	2.30	2.25	2.20	2.20
6 ".....	"	6.10	5.20	4.50	4.00	3.50	3.25	3.15	3.10	3.00	3.00

For cuts showing sizes of Chain, see page 708.

STEEL WIRE HALTER AND DOG CHAINS

BROWN'S PATENT

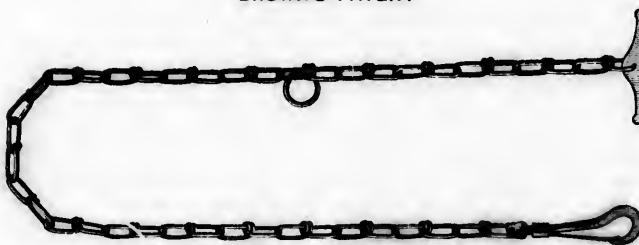

Nos.....		3-0	2-0	0	1	2	4
4½ feet.....	per doz.	\$4.30	4.10	3.80	3.60	3.20	2.80
6 ".....	"	5.30	4.80	4.30	4.00	3.50	3.00
9 " with Centre Swivel.....	"	7.40	6.80	6.20	5.60	5.10	4.40

KENNEL CHAINS

Nos.....		3-0	2-0	0	1	2
4½ feet.....	per doz.	\$5.75	5.00	4.50	4.00	3.50
6 ".....	"	7.25	6.25	5.50	5.00	4.50
9 ".....	"	9.00	7.75	6.75	6.25	5.50

These Chains are made similar to the Dog and Halter Chains, but instead of Toggle at one end, are fitted at each end with Swivel Snap.

For cuts showing sizes of Chain, see page 707.

ENGLISH TRACE CHAINS

STRAIGHT OR TWISTED LINKS

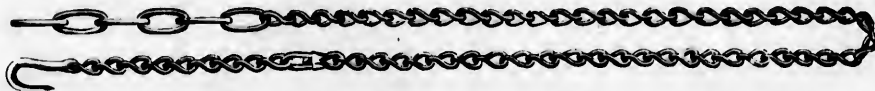

Size	3½ x 10 x 1	3½ x 10 x 2	3½ x 10 x 3	3½ x 10 x 4 inch.
Per dozen pairs.....	\$7.00	5.75	5.00	4.60
Size	7 x 12 x 1	7 x 12 x 2	7 x 10 x 3	7 x 10 x 4 inch.
Per dozen pairs	\$14.00	12.25	9.50	8.00

BLUE TEMPERED STEEL TRACE CHAINS

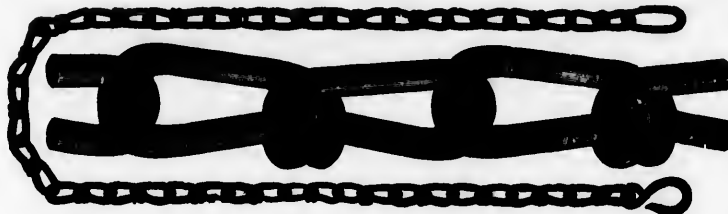

Length.....	3½	6½	7	7½ feet.
Per pair.....	\$0.60	0.85	0.90	0.98

Half-dozen pairs in a box.

AMERICAN TRACE CHAINS

7 feet.....		per pair	\$0.90
-------------	--	----------	--------

POST CHAINS



Nos.....		0	1
2½ feet.....	per doz.	\$2.70	2.60

SPECIAL TIE CHAINS

No.....		2
Bright, 7 feet long.....	per doz.	\$5.00
Nickeled, 7 ".....	"	7.00

These Chains are made with a Swivel Snap at each end. The Snap will Catch any Link.

TIE-OUT CHAINS

Nos.....					
20 feet, 2 Swivels	per doz.	1	0	2-0	3-0
30 " 2 "		\$13.50	15.00	17.00	20.00
40 " 2 "		19.00	21.00	24.50	28.00
50 " 3 "		24.00	28.00	32.00	37.00
60 " 3 "		30.00	33.00	39.00	46.00
80 " 3 "		35.00	39.00	45.00	52.00
75 " 3 "		40.00	45.00	52.00	59.00
100 " 4 "		53.00	60.00	69.00	79.00

These Chains have Stake Rings, Swivels and a Swivel Snap. They are the best Chains on the market for tethering cattle.

For Cuts showing Sizes of Chains, see page 707.

Nos
Op
Sm
Lar
Th
Put

STEEL BREAST CHAINS



Size..... 28 inch.
 American Pattern, Bright Steel..... per pair \$0.60

GREENING'S COW TIES

BROWN'S PATENT STEEL CHAIN



OPEN RING

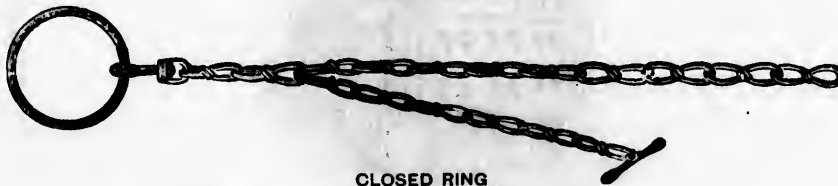

CLOSED RING

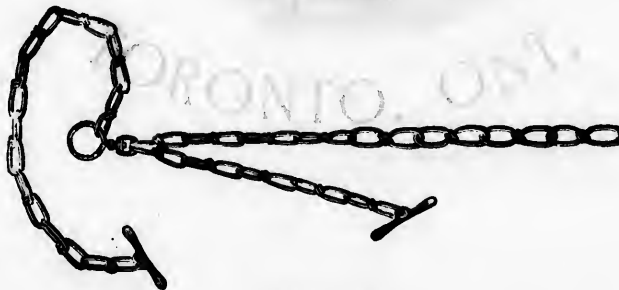

THREE CHAIN

Nos	5-0	4-0	3-0	2-0	0	1
Open Ring.....per doz.	\$5.00	4.10	3.30	3.00	2.80	2.25
Small Closed Ring (2½ inch diameter).....	5.00	4.10	3.30	3.00	2.80	2.25
Large " (4 " ").....	5.00	4.10	3.30	3.00	2.80	2.25
Three Chain (or Ohio Pattern).....	5.00	4.10	3.30	3.00	2.80	2.25

Put up ½ dozen in a box, 12 dozen in a case. Closed Ring Cow Ties are made with two sizes of Rings, 2½ and 4 inch diameter. 2½ inch Ring will be sent unless otherwise ordered. For full size cut of Link, see page 707.

x 10 x 4 inch.
4.60

10 x 4 inch.
9.00

7½ feet.
0.98

per pair \$0.00

0 \$2.70 1 2.60

per doz. \$5.00 7.00

nk.

2-0 3-0
17.00 20.00
24.50 28.00
32.00 37.00
39.00 46.00
45.00 52.00
52.00 59.00
60.00 79.00

in the market for

AMERICAN COW TIES



CLOSED RING
SHOWING STALL FIXTURE



OPEN RING



THREE CHAIN

CLOSED RING				
Nos.....	4-0	3-0	2-0	0
Per dozen	\$4.75	4.00	3.50	3.25

OPEN RING				
Nos.....	4-0	3-0	2-0	0
Per dozen	\$4.75	4.00	3.50	3.25

THREE CHAIN or Ohio Pattern, with two Toggles.				
Nos.....	4-0	3-0	2-0	0
Per dozen	\$4.50	3.75	3.25	3 00

For Cuts showing Sizes of Chains, see page 708.

STALL FIXTURES

Stall Fixtures only, as shown with Closed Ring Cow Tiewithout Tie, per doz. \$1.50

ENGLISH COW TIES



CLOSED RING

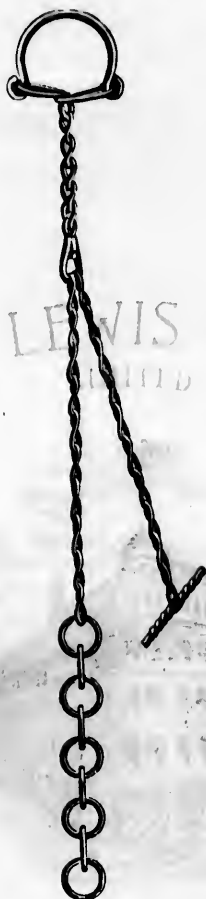

OPEN RING



THREE CHAIN

RICE LEWIS & SON

TORONTO, ONT.

CLOSED RING

Nos.....	21	22	23	31	32	33
Size of Ring, inside diameter.....	$\frac{1}{2} \times 2\frac{1}{2}$	$\frac{1}{2} \times 2\frac{1}{2}$	$\frac{3}{4} \times 2\frac{1}{2}$	$\frac{1}{2} \times 4$	$\frac{1}{2} \times 4$	$\frac{3}{4} \times 4$
Price..... per doz.	\$4.40	3.75	2.75	4.55	3.00	2.00

Nos. 21, 22, 31 and 32 have 5 Close Twisted Links between Ring and Swivel; Nos. 23 and 33 have 4, all supplied with Toggle Fastenings.

OPEN RING

Nos.....	1	2	3	4	5
Size of Ring, outside diameter.....	$\frac{1}{2} \times 5\frac{1}{2}$	$\frac{1}{2} \times 5$	$\frac{3}{4} \times 4\frac{1}{2}$	$\frac{1}{2} \times 4\frac{1}{2}$	$\frac{1}{2} \times 4$
Price..... per doz.	\$5.50	4.80	3.60	3.20	2.55

Nos. 1 and 2 have 5 Close Twisted Links between Ring and Swivel; No. 3 has 4; Nos. 4 and 5 have 1, 2-inch Straight Link, all supplied with Toggle Fastenings.

THREE CHAIN OR WALTON PATTERN

Nos.....	7	17	27	37
Price..... per doz.	\$3.00	3.50	4.25	5.75

Supplied with Toggle Fastenings.

CHAIN

0
3.25

0
3.25

0
3.00

oz. \$1.50

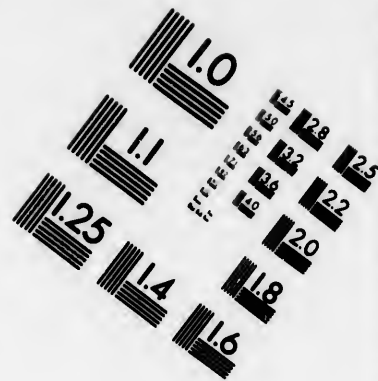
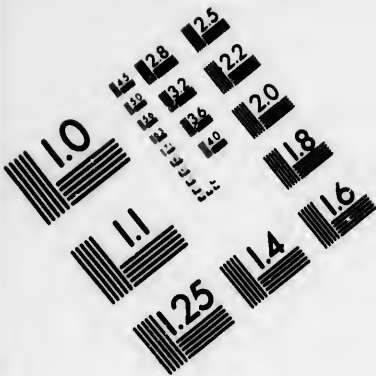

**IMAGE EVALUATION
TEST TARGET (MT-3)**

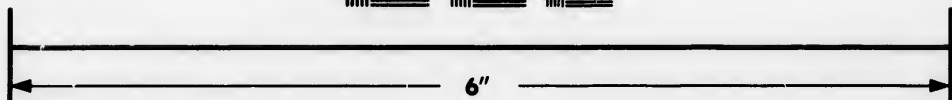
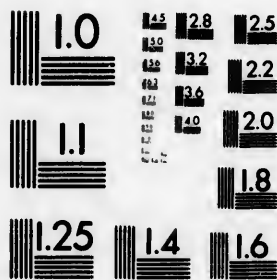

**Photographic
Sciences
Corporation**

23 WEST MAIN STREET
WEBSTER, N.Y. 14590
(716) 872-4503

1.8
2.0
2.2
2.5
2.8
3.2
3.6
4.0

10
11

HOG TONGS AND RINGERS

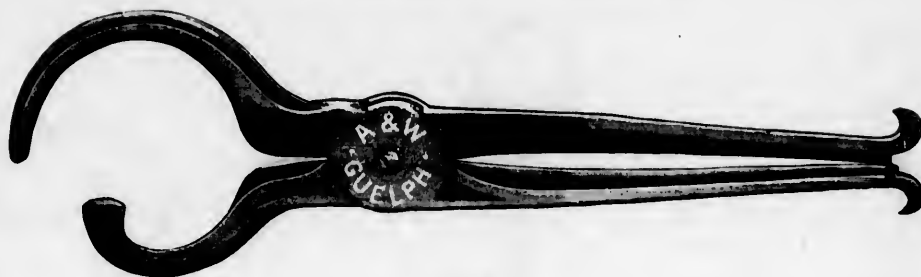

No. 4

No. 4—Hill's Pattern Hog Tongs, Malleable Iron.....per doz. \$4.30

Half dozen in a box.

ADJUSTABLE HOG RINGER

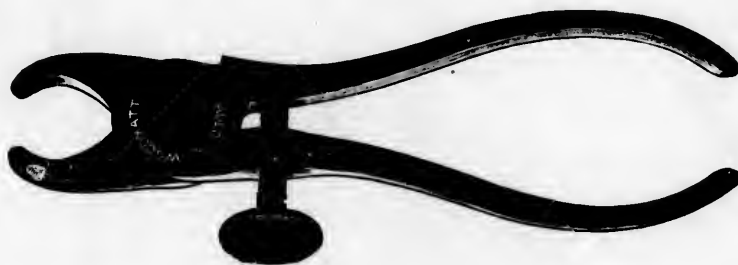

No. 1—Adjustable Hog Ringers.....per doz. 1.05

One dozen in a box.

COPPERED STEEL WIRE HOG RINGS

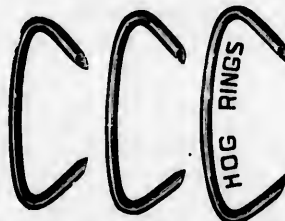

Nos. 1

2

3

Nos. 1, 2 or 3.....per 1000 0.60

One hundred in a box.

Price.

Handl
direct

Home Co

Nos.

Star Las

Star Las

ECONOMY COBBLERS



A Complete Outfit of Tools and Materials for Boot and Shoe Repairing.

Price..... per doz. sets \$0.00

CONTENTS.—Iron Stand, Last for Men's, Boys' and Woman's Work, Shoe Hammer, Shoe Knife, Peg Awl and Handle and Wrench, Sewing Awl and Handle, Stabbing Awl and Handle, Package of Heel and Clinch Nails, with directions for half-soleing.

SHOE LASTS



HOME COBBLERS

STAR LASTS AND STAND

Home Cobblers, Japanned, 1 Set in a Box..... per set \$1.25

Nos. 0 1 2 3 4 5

Star Lasts, Japanned..... per doz. \$0.70 0.88 0.95 1.05 1.50 1.75

Star Last Stands, Japanned..... per doz. \$1.95

TRUCKS



WAREHOUSE TRUCKS
New York Pattern, Half Ironed.



RAILROAD TRUCKS
Western Pattern, Heavy Full Ironed.

STORE AND WAREHOUSE TRUCKS

New York Pattern, Half Ironed, Axle Bearings Turned, Wheels Bored True to Centre.

No.	Length	width at Nose	width at Upper Bar	size of Wheel	Each.
No. 1	48 inches	13 inches	18 inches	6 1/2 x 1 1/2 inches	\$4.15
" 2	53 "	14 "	19 "	7 1/2 x 2 "	5.75
" 3	56 "	15 "	20 "	9 x 2 1/2 "	7.50

EXTRA HEAVY RAILROAD TRUCKS

Western Pattern, Full Ironed, One Centre Strap Welded to Nose, Axle Bearings Turned, Wheels Bored True to Centre.

No. 4	Length 60 inches,	width of Truck 24 inches,	diameter of Wheels 11 inches,	weight 128 lbs.	each 15.00
-------	-------------------	---------------------------	-------------------------------	-----------------	------------



BAG TRUCK
No. 10, Cast Iron Nose.



HANDY TRUCK
No. 11, Half Ironed.



HOTEL TRUCK
Nos. 21 and 22, Rubber-Banded Wheels.

No.	Length	width at Nose	width at Upper Bar	diam. of Wheels	Each.
No. 10	42 in.	11 in.	17 in.	6 in.	\$ 3.15
" 11	46 "	12 "	17 "	6 "	2.80
" 21	46 "	19 in., with Rubber-Banded	17 in.	6 in.	10.00
" 22	52 "	20 "	7 1/2 in.	7 1/2 in.	12.00
" 12	53 "	width at Nose 14 in., width at Upper Bar	19 in.	diam. of Wheels 7 1/2 in.	7.40
" 13	56 "	15 "	20 "	9 "	10.25

Barrel Trucks, New York Pattern, Three Curved Iron Cross Bars, Upper Bar Wood, Strapped up.

FACTORY TRUCKS AND EXPRESS WAGONS



No. 620



No. 631

- No. 620—Factory Truck, Platform 27 x 48 inches, Iron-Strapped around the outside, with 6 Removable Stakes 36 inches high, can be used at either ends or sides..... each \$21.25
- " 631—Express Wagon, Light Pattern, Platform 84 x 30 inches, 22 inches high, End Rails 36 inches high, made of the best material, Strongly Ironed and Braced, Painted..... each 49.50

Ironed.

Each.
... \$4.15
... 5.75
... 7.50

Each 15.00

BAGGAGE BARROWS



No. 629

- No. 629—Baggage Barrows, Light Pattern, Covered Top, Platform 84 x 24 inches, Wheels 14 x 2 1/2 inches, each 28.75

TORONTO, ONT. GIANT CAR PUSHERS



No. 550

- No. 550—Giant Car Pusher, Weight 24 lbs., easy to handle..... each 8.75

Wheels.
Each.
... \$ 3.15
... 2.80
... 10.00
... 12.00
... 7.40
... 10.25

PAPER CLIPS

Full size cut.



No. 240

No. 240—Tuscan Bronzed.....per doz. \$0.95

PAPER FILES

Half size cuts.



No. 24

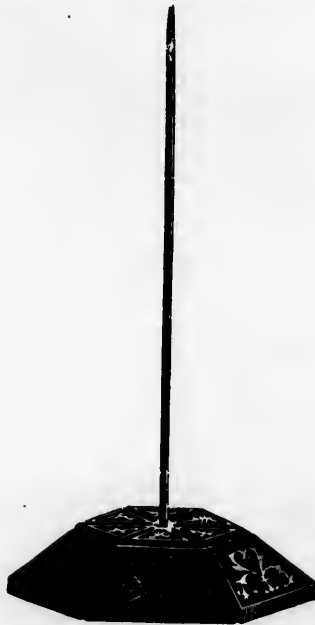

No. 37



No. 34

No. 24—Tuscan Bronzed, Paper File Hooks.....	per doz.	0.70
" 37—Berlin " " Files.....	"	1.25
" 34—Tuscan " " File Hooks.....	"	0.90

No. 2—

" 3—

No. 76—

" 113—

ALARM TILLS

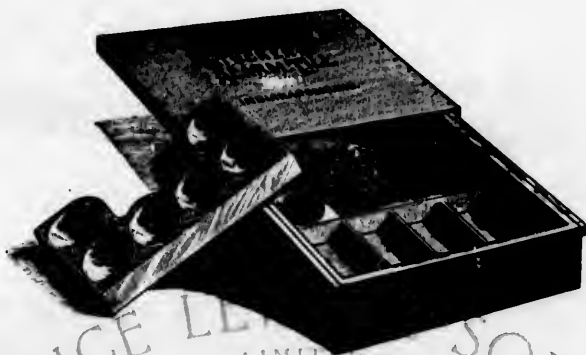

- No. 2—Tucker's Alarm Tills, or Money Drawers, Ash Front, Varnished, 4 Spaces for Bills, Sliding Tray, with 6 Cups.....each \$2.25
- " 3—Miles' Alarm Tills, Hardwood Front, Varnished, 4 Spaces for Bills, Sliding Tray, with 6 Cups. . . 3.00
- Half-dozen in a crate.

TWINE BOXES

Half size cuts.



No. 76



No. 113

- No. 76—Berlin Bronzed.....per doz. \$7.50
- " 113—Copper Bronze, large, Patent Catch..... " 3.00
- No. 76, one-sixth dozen in a box; No. 113, quarter dozen.

TOBACCO CUTTERS



No. 12

No. 12—"Clipper," Bronzed and Ornamented, opening $1\frac{1}{2}$ x $3\frac{1}{2}$ inches, whole length 16 inches each \$1.65

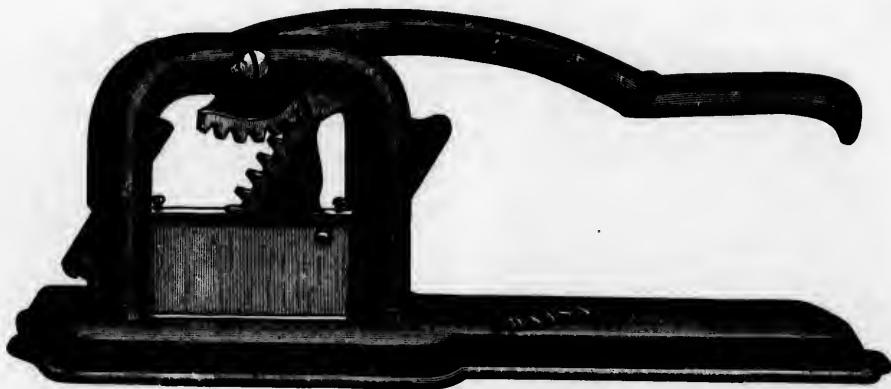

No. 21

No. 21—"Daisy," Bronzed and Ornamented, with Gauge, opening $1\frac{1}{2}$ x 4 inches, whole length $17\frac{1}{2}$ inches . . each 2.00

APPLE PARERS

HUDSON'S

LITTLE STAR

With Push-off, Combined Parer, Corer and Slicer.

Per dozen, \$7.50.

The Parer Knife always faces the fruit when brought against it. The machine is so arranged that parings and juice cannot fall upon it.

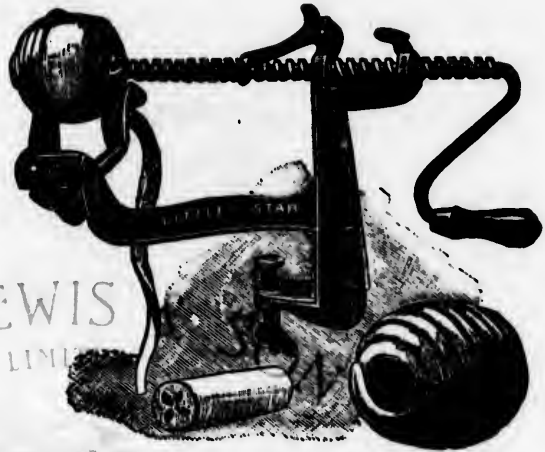

LITTLE STAR

RICE LEWIS
LIM

ch \$1.05

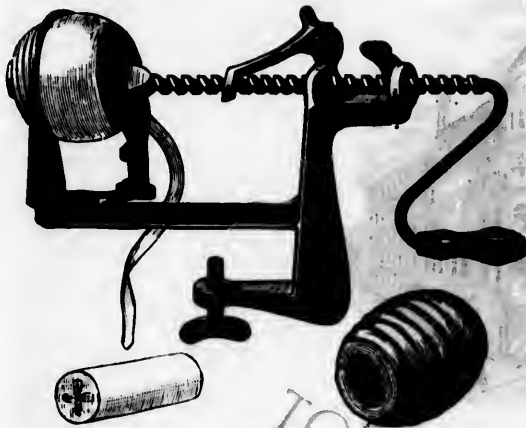

DAISY

With Push-off, Combined Parer, Corer and Slicer.

Per dozen, \$7.15.

DAISY

TORONTO

ROCKING TABLE

With Push-off and Improved Clamping Device.

Per dozen, \$7.50.

This machine is so arranged that parings and juice cannot fall upon it.

One dozen in a box.



ROCKING TABLE

ch 2.00

PORTABLE PLATFORM SCALES

WITH BRASS SLIDING POISE AND HEAVY BEVEL EDGE PLATFORM

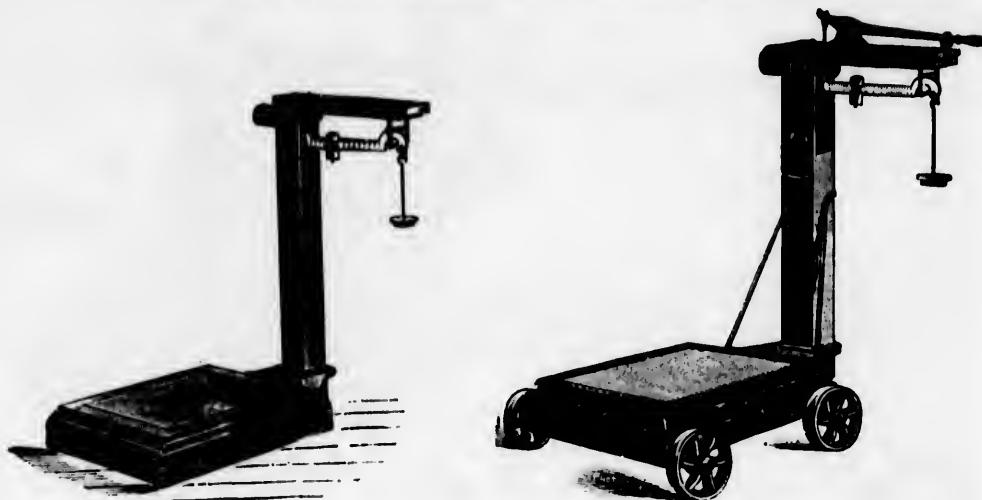

WITHOUT WHEELS

No.	Capacity	Platform	Dimensions	Configuration	Price	Inspection
No. 20	400 lbs.	Platform	21 x 15 inch	without Pillar Braces	\$23.00	0.75
" 22	600 "	"	25 x 16 "	"	27.00	1.00
" 24	1000 "	"	26 x 17 "	"	32.00	1.00
" 26	1200 "	"	28 x 19 "	"	36.00	1.00
" 28	1500 "	"	28 x 21 "	with	41.00	1.00
" 30	2000 "	"	31 x 24 "	"	46.00	1.00
" 32	2500 "	"	31 x 24 "	"	53.00	1.50

WITH WHEELS

No.	Capacity	Platform	Dimensions	Configuration	Price	Inspection
No. 34	400 lbs.	Platform	21 x 15 inch	without Pillar Braces	\$26.00	0.75
" 36	600 "	"	25 x 16 "	"	30.00	1.00
" 38	1000 "	"	26 x 17 "	"	35.00	1.00
" 40	1200 "	"	28 x 19 "	"	40.00	1.00
" 42	1500 "	"	28 x 21 "	with	45.00	1.00
" 44	2000 "	"	31 x 24 "	"	51.00	1.00
" 46	2500 "	"	31 x 24 "	"	58.00	1.50

WITH WHEELS AND DROP LEVER

No.	Capacity	Platform	Dimensions	Configuration	Price	Inspection
No. 48	1200 lbs.	Platform	26 x 17 inch	with Pillar Braces	\$42.00	1.00
" 50	1500 "	"	28 x 19 "	"	48.00	1.00
" 52	2000 "	"	28 x 21 "	"	55.00	1.00
" 54	2500 "	"	31 x 24 "	"	62.00	1.50
" 56	3000 "	"	31 x 24 "	"	70.00	1.50

BRASS SLIDING POISE BEAM



HEAVY BEVEL EDGE PLATFORM



Furnished with these Platform Scales.

MEAT, FISH AND DAIRY SCALES

MEAT AND FISH SCALE

With Brass Sliding Poise and Bevel Edge Iron Platform.



WITHOUT WHEELS

No.	Capacity.	Platform.	Each.	Inspection.
No. 110	600 lbs.	23 x 16 inch.....	\$30.00	1.00
" 112	1000 "	25 x 17 "	35.00	1.00

WITH WHEELS

No.	Capacity.	Platform.	Each.	Inspection.
No. 114	600 lbs.	23 x 16 inch.....	\$33.00	1.00
" 116	1000 "	25 x 17 "	38.00	1.00

GALVANIZED SCALES

All the Iron Work inside and outside Galvanized.

600 lb. Fish Scale, additional for Galvanizing.	\$11.00
1000 " " " " " "	13.00

DAIRY SCALE

With Double Beam and Brass Sliding Poises.

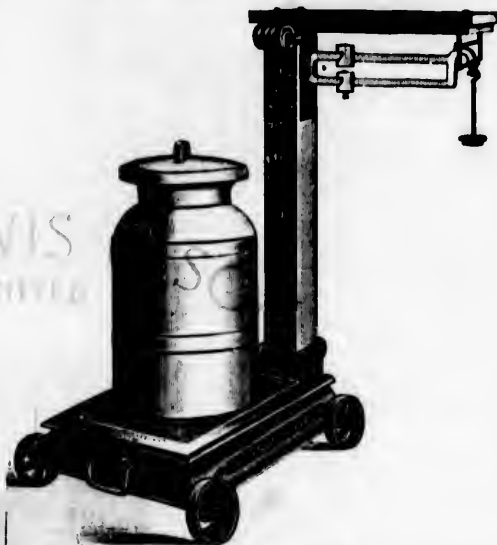

WITHOUT WHEELS

No.	Capacity.	Platform.	Each.	Inspection.
No. 102	600 lbs.	25 x 16 inch.....	\$30.00	1.00
" 104	1000 "	26 x 17 "	35.00	1.00

WITH WHEELS

No.	Capacity.	Platform.	Each.	Inspection.
No. 106	600 lbs.	25 x 16 inch.....	\$33.00	1.00
" 108	1000 "	26 x 17 "	38.00	1.00

DORMANT WAREHOUSE SCALE

With Brass Sliding Poise and Square Edge Platform.

No.	Capacity.	Platform.	Each.	Inspection.
No. 96	5000 lbs.	48 x 48 inch.....	\$160.00	2.00
" 98	4000 "	42 x 44 "	130.00	1.50
" 100	3000 "	31 x 40 "	115.00	1.50

EXTRA FOR DOUBLE BEAMS

Add \$6.00 to List on Nos. 98 and 100; \$8.00 to List on No. 96.



WITH TWO IRON PILLARS

CHAMPION AND BATHROOM SCALES



CHAMPION EVEN BALANCE SCALE



CHAMPION UNION SCALE

No. 600—Champion Even Balance, with Tin Scoop, Capacity	oz. to 4 lbs.....	each	\$ 5.00	0.50	Inspection.
" 601— " " " " " " " " " " " "	" 10 "	"	7.50	0.50	
" 602— " " Union Scale, " " " " " "	" 240 "	"	11.00	0.50	



CHAMPION PLATFORM SCALES

No. 603—Champion Platform, Cap. 600 lbs., with Wheels....	each	\$28.00	1.00	Inspection.
" 604— " " " " 600 " without "	"	26.00	1.00	
" 605— " " " " 1200 " with "	"	35.00	1.00	
" 606— " " " " 1200 " without "	"	33.00	1.00	

BATHROOM SCALES

No. 607—With Measuring Rod	each	\$35.00
" 608—Without " "	"	30.00

This Scale is suitable for use in bathrooms, also for doctors' and insurance offices. It is constructed of Iron and Brass throughout, finished in Pale Blue Enamel, with Nickel-Plated Beam and Sliding Poise. A tall Pillar places the Beam on a level with the eye. Capacity 250 lbs., by one ounce divisions; platform 14½ x 10 inches.

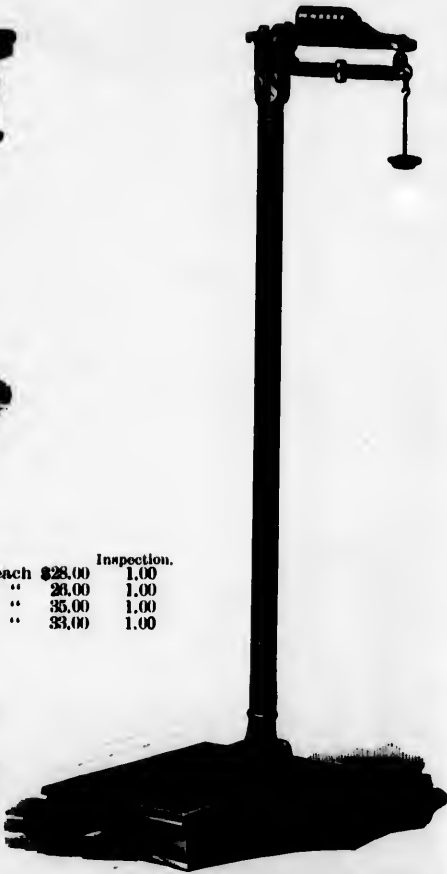

BATHROOM SCALES

PLATFORM COUNTER SCALE

SLIDING POISE



No. 500—Capacity 2 oz. to 240 lbs., Platform 19 x 13.....each \$20.00

Inspection.
0.50

UNION OR FAMILY SCALE



UNION MEAT SCALE



UNION OR FAMILY SCALE

No. 502—Capacity 1/2 oz. to 240 lbs., Tin Scoop.....each \$12.00
 " 504— " " " 240 " Brass Scoop..... " 13.00
 " 506— " " " 240 " Double Beam, Tin Scoop..... " 13.00
 " 508— " " " 240 " " Brass Scoop..... " 14.00

Inspection.
0.50
0.50
0.50
0.50

UNION MEAT SCALE

No. 510—Capacity 1/2 oz. to 240 lbs., Round or Square Porcelain Plate.....each \$14.00
 " 512— " " " 240 " " Double Beam..... " 15.00

Inspection.
0.50
0.50

For Sliding Poise, add \$1.00 extra to List on S. B. Scales. Sliding Poise not furnished on D. B. Scale.



DRUGGISTS' SCALE

No. 494—Capacity 1 drachm to 8 lbs., Tin Scoop, each.....\$10.00
 " 496—Capacity 1 drachm to 8 lbs., Brass Scoop, each.....11.00

Inspection.
0.50
0.50

BUTCHERS' SCALES

WITH BRASS BEAM AND SLIDING POISE

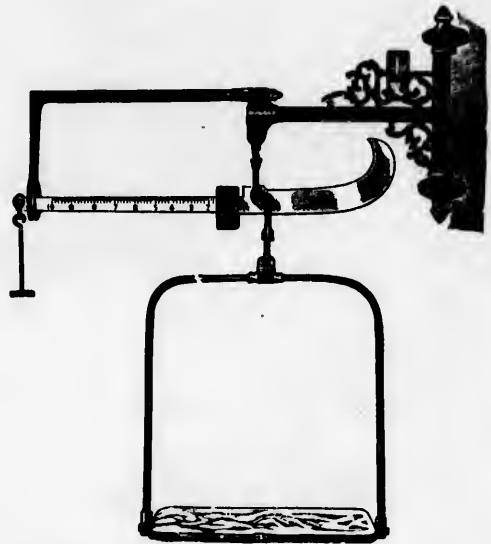
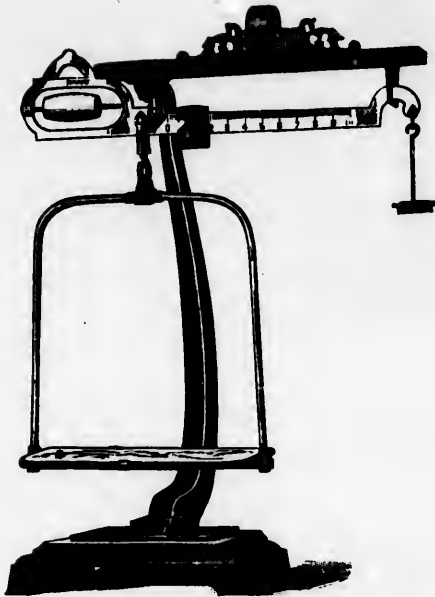

No. 524—Capacity 60 lbs., Porcelain Plate..each \$17.00 | No. 528—Capacity 50 lbs., Porcelain Plate..each \$15.00
 " 530— " 50 " Tin Dish..... " 14.00
 Inspection, \$0.50 each.

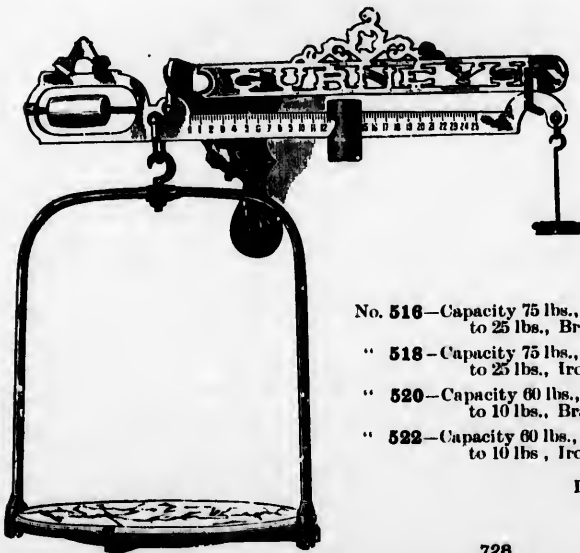

No. 516—Capacity 75 lbs., 15 inch Porcelain Plate, Beam marked to 25 lbs., Brass Weights and Counterpoiseeach \$27.00
 " 518—Capacity 75 lbs., 15 inch Porcelain Plate, Beam marked to 25 lbs., Iron Weights and Counterpoiseeach 25.00
 " 520—Capacity 60 lbs., 12 inch Porcelain Plate, Beam marked to 10 lbs., Brass Weights and Counterpoiseeach 21.00
 " 522—Capacity 60 lbs., 12 inch Porcelain Plate, Beam marked to 10 lbs., Iron Weights and Counterpoiseeach 19.00

Inspection, \$0.50 each.

No.
 ..
 ..
 ..
 ..
 ..
 ..

ATTN



No. 53
 " 53

IMPROVED WEIGH BEAMS

STEEL BAR

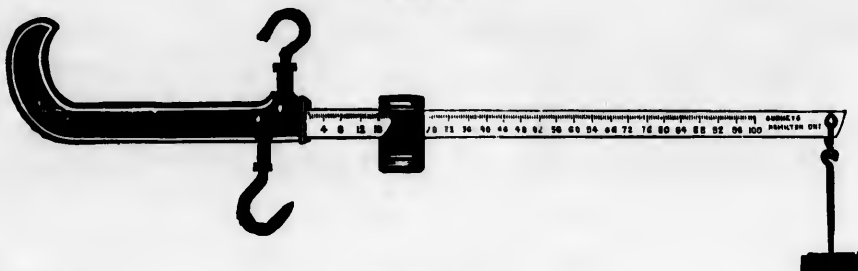

No.	Capacity.	Engraved on Beam,	one	25 lb. Counterpoise.	Each.	Inspection.
No. 554	100 lbs.	80 lbs.	one	25 lb. Counterpoise.	\$4.10	0.50
" 556	150 "	80 "	"	"	4.35	0.50
" 558	200 "	80 "	"	"	4.60	0.50
" 562	250 "	80 "	"	"	4.85	0.50
" 564	300 "	80 "	"	"	5.10	0.50
" 564	350 "	100 "	"	"	5.70	0.50
" 566	400 "	100 "	"	"	6.00	0.50
" 568	500 "	100 "	"	"	6.40	0.50
" 570	600 "	100 "	"	"	6.80	0.75

The Counterpoise is sealed and represents the first weight required when hung on beam. This is a handy arrangement for weights, and superior in this respect to any other beam now made.

PEDLER OR BUTCHER BEAMS

Brass Beam with Sliding Poise.

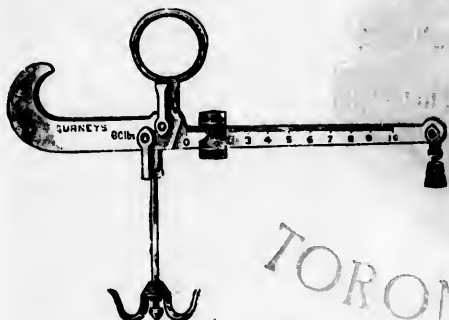

No. 538	Capacity	25 lbs., to Weigh by Hand	each	\$ 6.00
" 540	"	50 "	"	7.00
" 542	"	60 "	"	8.00
" 544	"	100 "	"	10.00
" 546	"	25 " with Wagon Attachment	"	7.00
" 548	"	50 "	"	8.00
" 550	"	60 "	"	9.00
" 552	"	100 "	"	11.00

Inspection, each, \$0.50.

PACKAGE AND POSTAL SCALES

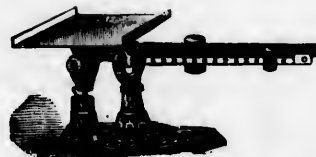
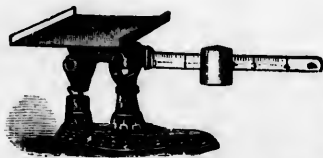

No. 532	Capacity	$\frac{1}{4}$ to 8 ozs.	Each.	\$4.00
" 534	"	$\frac{1}{4}$ " 34 "	0.00	
No. 536	Capacity	$\frac{1}{2}$ oz. to 4 lbs.	Each.	\$8.00
No. 537	Capacity	$\frac{1}{2}$ oz. to 6 lbs., Double Beam	Each.	\$12.00

Letter Scales do not require to be inspected.

GROCCERS' SCALES

TEA SCALE

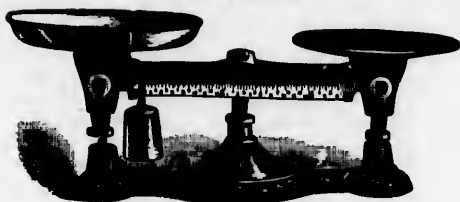

WITH IRON WEIGHTS AND BRASS DISH
Without Side Beam.

No.	Capacity.	Each.	Inspection.
No. 396	oz. to 17 lbs.	\$10.00	0.90
" 398	" 10 "	7.60	0.75
" 400	" 6 "	6.30	0.70
With Side Beam.			
No. 402	oz. to 17 lbs.	11.40	0.50
" 404	" 10 "	8.70	0.50
" 406	" 6 "	7.20	0.45

MEAT SCALE

WITH ROUND OR SQUARE PORCELAIN PLATE

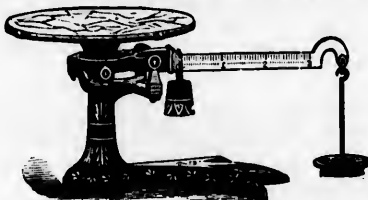

No.	Capacity.	Each.	Inspection.
No. 462	oz. to 36 lbs., Notched Beam	\$11.00	0.50
" 464	" 36 " Sliding Poise..	12.00	0.50
" 466	" 62 " Notched Beam	12.00	0.50
" 468	" 62 " Sliding Poise..	13.00	0.50

COUNTER SCALE



WITH SINGLE BEAM

No.	Capacity.	Each.	Inspection.
No. 474	oz. to 62 lbs., Tin Scoop....	\$11.00	0.50
" 476	" 62 " Brass "	12.00	0.50
" 478	" 62 " Tin "	12.00	0.50
" 480	" 62 " Brass "	13.00	0.50

Nos. 474, 476, Notched Beam; Nos. 478, 480, Sliding Poise.

WITH DOUBLE BEAM

No.	Capacity.	Each.	Inspection.
No. 482	oz. to 62 lbs., Tin Scoop....	\$12.00	0.50
" 484	" 62 " Brass "	13.00	0.50
" 486	" 62 " Tin "	14.00	0.50
" 488	" 62 " Brass "	15.00	0.50

Nos. 482, 484, Notched Beam; Nos. 486, 488, Sliding Poise.

BUTTER OR MEAT TRIP SCALE

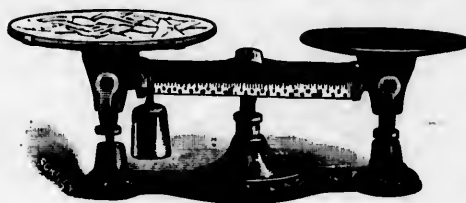

Price with Iron Weights Complete.

WITH TWO IRON PLATES
Without Side Beam.

No.	Capacity.	Each.	Inspection.
No. 414	oz. to 17 lbs.	\$ 8.50	0.80
" 416	" 10 "	6.40	0.75
" 418	" 6 "	5.40	0.70
With Side Beam.			
No. 420	oz. to 17 lbs.	9.90	0.50
" 422	" 10 "	7.50	0.50
" 424	" 6 "	6.30	0.45

WITH BRASS PLATE AND IRON PLATE
Without Side Beam.

No.	Capacity.	Each.	Inspection.
No. 426	oz. to 17 lbs.	\$ 9.70	0.80
" 428	" 10 "	7.30	0.75
" 430	" 6 "	6.20	0.70
With Side Beam.			
No. 432	oz. to 17 lbs.	11.10	0.50
" 434	" 10 "	8.40	0.50
" 436	" 6 "	7.20	0.45

WITH PORCELAIN PLATE AND IRON PLATE
Without Side Beam.

No.	Capacity.	Each.	Inspection.
No. 438	oz. to 17 lbs.	\$11.20	0.80
" 440	" 10 "	8.40	0.75
" 442	" 6 "	6.80	0.70
With Side Beam.			
No. 444	oz. to 17 lbs.	12.60	0.50
" 446	" 10 "	9.80	0.50
" 448	" 6 "	7.80	0.45

WITH PORCELAIN PLATE AND BRASS PLATE
Without Side Beam.

No.	Capacity.	Each.	Inspection.
No. 450	oz. to 17 lbs.	\$12.30	0.80
" 452	" 10 "	9.30	0.75
" 454	" 6 "	7.60	0.70
With Side Beam.			
No. 456	oz. to 17 lbs.	13.70	0.50
" 458	" 10 "	10.50	0.50
" 460	" 6 "	8.60	0.45

COUNTER SCALE

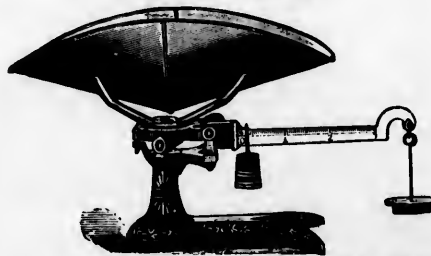

No.	Capacity.	Each.	Inspection.
No. 470	oz. to 36 lbs., Tin Scoop....	\$10.00	0.50
" 472	" 36 " Brass Scoop...	11.00	0.50

With Double Beam, add \$1.00 extra to List.

EVEN BALANCE SCALES



Without Side Beam, with Iron Weights complete.

WITH TIN SCOOP

No.	Capacity.	Each.	Inspection.
No. 306	oz. to 10 lbs.	\$6.00	0.75
" 308	" 6 "	5.40	0.70
" 310	" 4 "	4.20	0.55

WITH BRASS SCOOP

No.	Capacity.	Each.	Inspection.
No. 318	oz. to 10 lbs.	\$7.50	0.75
" 320	" 6 "	6.40	0.70
" 322	" 4 "	5.10	0.55



With Brass Side Beam, with Iron Weights complete.

WITH TIN SCOOP

No.	Capacity.	Each.	Inspection.
No. 330	oz. to 10 lbs.	\$7.50	0.50
" 332	" 6 "	6.00	0.45
" 334	" 4 "	4.80	0.30

WITH BRASS SCOOP

No.	Capacity.	Each.	Inspection.
No. 342	oz. to 10 lbs.	\$8.70	0.50
" 344	" 6 "	7.00	0.45
" 346	" 4 "	5.70	0.30

GROCERS' TRIP SCALES



Without Side Beam, with Iron Weights complete.

WITH TIN SCOOP

No.	Capacity.	Each.	Inspection.
No. 354	oz. to 17 lbs.	\$8.50	0.80
" 356	" 10 "	6.40	0.75
" 358	" 6 "	5.40	0.70

WITH BRASS SCOOP

No.	Capacity.	Each.	Inspection.
No. 366	oz. to 17 lbs.	\$10.00	0.80
" 368	" 10 "	7.80	0.75
" 370	" 6 "	6.30	0.70



With Brass Side Beam, with Iron Weights complete.

WITH TIN SCOOP

No.	Capacity.	Each.	Inspection.
No. 378	oz. to 17 lbs.	\$9.90	0.50
" 380	" 10 "	7.50	0.50
" 382	" 6 "	6.30	0.45

WITH BRASS SCOOP

No.	Capacity.	Each.	Inspection.
No. 390	oz. to 17 lbs.	\$11.40	0.50
" 392	" 10 "	8.70	0.50
" 394	" 6 "	7.20	0.45

PACKERS' SCALE



No.	Capacity.	Each.	Inspection.
No. 408	Capacity 4 lbs., without Weights	\$3.40	0.20
" 410	" 4 " with one 1 lb. Weight	3.60	0.25
" 412	" 4 " " 1 " and one 2 lb. Weight	3.80	0.30

COUNTER SCALES



CANADIAN COUNTER SCALE

Nickel-Plated Beams and Sliding Poises.

Capacity 1 oz. to 200 lbs. Platform 12 x 15 inches.

No. 514	--With Brass Scoop.....	each	\$29.00
" 515	-- " Tin "	"	23.00
" 515 $\frac{1}{2}$	--Without Scoop	"	27.00
Inspection	"	0.50

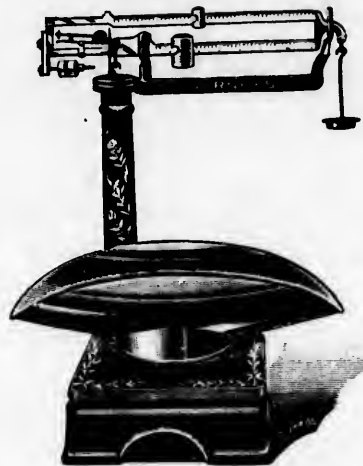

DOMINION COUNTER SCALE

With Patent Automatic Scoop Balance, balancing the Scale automatically with Scoop off or on the Platform; Nickel-Plated Beam, Poises and Scoop Balance; Double Beam marked on both sides.

Capacity 1 oz. to 200 lbs. Platform 11 x 14 inches.

No. 516	--With Brass Scoop.....	each	\$30.00
Inspection	"	0.50

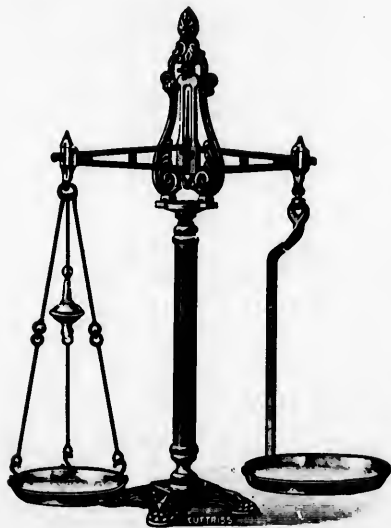

TEA SCALES

WITH BRASS STANDARD

No.	Capacity	Height of Standard	Each.	Inspection.
No. 490	—Capacity 7 lbs.,	Height of Standard 31 in.	\$20.00	0.30
" 492	— " 12 " " "	" " 36 in.	23.00	0.30

Priced without Weights.

For price of Weights see page 730.

No. 44

No. 24

Capacity
No. 16..

Will
milligramm
has ' Agate
bows, etc.,
door. Thi
colleges, un

BALL SCALES

TROEMNER'S

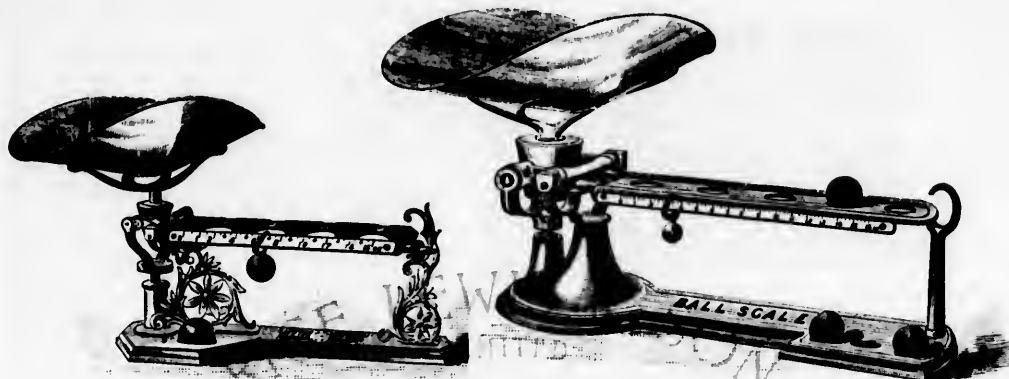

No. 44

No. 24

- No. 44—Capacity 5 lbs., by quarter ounces, Ornamented, adapted for candy, tea, spices, etc., Brass Scoop, 15 x 8 inches each \$14.00
- No. 24—Capacity 16 lbs., by quarter ounces, Finished in Gold Bronze and Nickel, Solid Seamless Brass Scoop, 19 x 10½ inches each 16.80

Inspection, \$0.50 each.

TROEMNER'S ANALYTICAL BALANCES



No. 16

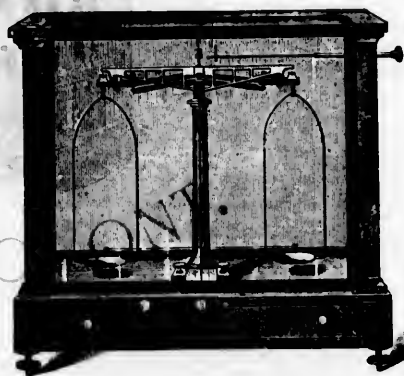

No. 119

Capacity each pan 100 grammes.
No. 16 each \$60.00

Capacity each pan 100 200 500 grammes.
No. 119 each \$140.25 173.25 214.50

Will carry a load of 100 grammes in each pan, sensible to 1-10 milligramme, beam is 6 inches long and divided in 1-5 milligramme, has "Agate" bearings, with improved pan arrests and extra wide bows, etc., etc. French polished mahogany case with counterpoised door. This Balance is especially desirable for students' use in colleges, universities, etc., etc.

Balances 100 grammes in each pan, sensible to 1-20 milligramme, beam 10 in. divided into 1-10 milligramme pans 2½ in., improved arrest for pans, apparatus for specific gravity.

200 grammes, sensible to 1-20 milligramme, beam 12 in. divided into 1-10 milligramme, pans 3 in., all bearings of "Agate" with improved pan arrest and apparatus for specific gravity.

500 grammes, sensible to 1-10 milligramme, all bearings "Agate" planes, has 18 in. beam divided into 1-10 milligramme, 5 in. pans, specific gravity apparatus.

All in fine French polished mahogany case with counterpoised sliding doors.

ASSAY BALANCES

TROEMNER'S



No. 134.....each \$158.75

Has great sensibility, the needle indicating 40 full divisions for 1 milligramme. Beam graduated into 1-10 milligramme. All bearings of "Agate." Open beam of pure aluminum, has new improved arrest for riders, mahogany case with glass top, bottom of heavy plate glass. Balance is sensible to 1-100 milligramme. In use at the U. S. Assay Offices at New York, St. Louis and the U. S. Mints at New Orleans, Philadelphia, etc., etc.

IMPROVED PORTABLE ASSAY BALANCE

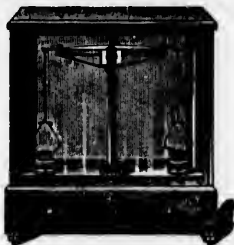
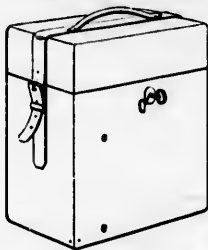

No. 132.....each \$115.50

In a very fine French polished case, beam and needle not disturbed when packed up, case 9 1/2 inches long, 9 1/2 inches high and 3 inches deep, total weight only 5 1/2 lbs., needle divides 20 full divisions for 1 milligramme. Balance is provided with rider apparatus, beam divided into 1-10 milligramme. A full set of Platinum weights included.

PULP SCALE



No. 26.....each \$44.55

This Balance is in general use in mining sections for weighing pulp, etc., etc. In a French polished mahogany case with counterpoised sliding door, has movable nickel pans, adjusting screws on the beam, eccentric lift, case is provided with glass level and leveling feet. Scale is sensible to 1-30 grain, capacity 3 oz. in each pan.

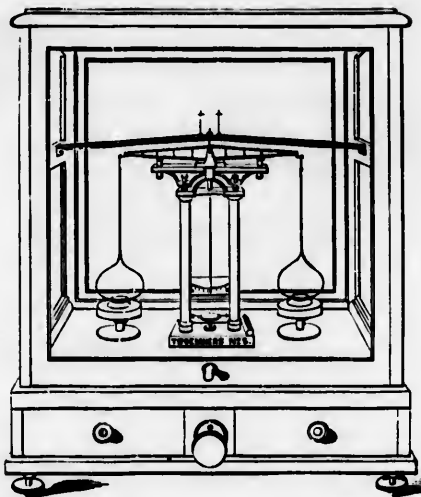

No. 130.....each \$288.75
" 138....." 247.50

No. 138 same as No. 130 in all respects, except it is a "short-arm," the beam is only 6 inches long.

No. 130 Balance is of the very finest and most delicate construction. Beam and its hangings of pure aluminum, all bearings of "Agate," with agate knives, has double column, with improved eccentric lift, working smooth and regular, releasing the pans first, then the beam, by the one operation; both arms of beam are graduated into equal parts, glass case of the finest finish, and is large and roomy, has glass top to admit light freely, bottom of case is very heavy plate glass. The Balance has the very highest attainable sensibility, the needle indicating 50 divisions for 1 milligramme.



No. 10—Short Arm.....each \$206.25

Short arm pure aluminum beam, agate planes and "Agate" knives, no steel used, both arms of the beam are graduated, the pans also of aluminum, all the brass work is plated with gold, elegant mahogany case (old wood), with heavy plate glass bottom, case has glass top to admit light freely, is provided with improved self-locking pan arrest (push in the button, turn slightly to the left, this locks the arrest). Balance will carry 200 grammes, and is sensible to 1-20 milligramme. All the workmanship is of the very finest. This Balance is in use at U. S. Coast Survey, and by all the large steel and iron works.

No. 15

Will

its hang

No. 17

Same

Same

No. 1-1

" 2-1

" 3-

For we

polished b

improved

grain, all o

BULLION BALANCES

TROEMNER'S



No. 157—Without Weights.....each \$340.50

Will carry 2000 ounces in each pan; open brass beam, pans and arches also of brass; has the complex levers to arrest the beam and its hangings, platform is of iron neatly japanned, has adjusting screws on beam, glass level and levelling feet, sensible to 1-200 of an ounce.

No. 170—Without Weights.....each \$204.00

Same as the above in all respects, capacity is 500 ounces in each pan, and sensible to 1 grain.

For Price of Weights, see page 730.

CHEMICAL SCALE

JEWELLERS' GOLD SCALE



No. 22

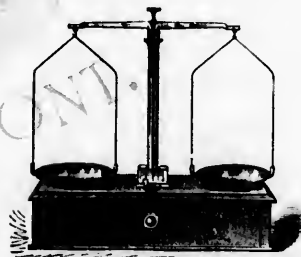

No. 138

No. 1—14 inch Beam, 6 inch Pans, Cap. 25 oz. each \$30.00

" 2—10 " 4 " " 10 " " 29.70

" 3—8½ " 3 " " 5 " " 24.75

For weighing pulp, chemicals, quinine, jewellery, etc. On French polished box with drawer, pans are movable and nickel-plated, has improved lever, beam has adjusting screws, scales sensible to 1-30 grain, all of the finest finish.

No. 0—13 inch Beam, 6 inch Pans, Cap. 64 oz. each \$30.00

" 1—10 " 5 " " 32 " " 24.75

" 2—9 " 4 " " 16 " " 19.80

" 3—7 " 3½ " " 8 " " 16.50

" 4—6¼ " 3 " " 4 " " 13.20

For jewellers, brokers, etc. Indicator pointing downward; on a polished walnut box, with drawer; very accurately adjusted; a set of Troy cup weights included.

For Price of Weights, see page 730.

DRUGGISTS' BOX SCALES

TROEMNER'S

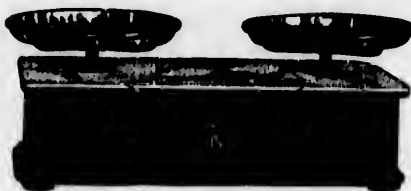

No. 89

In Ebony Box, Gold Lines, Gilt Dial, Heavy Nickel-Plated Pans, Marble Top.

No. 0—7 inch Pans, Capacity 10 lbs., without Weights.....	each	\$19.80
" 1—8 " " " 15 " " "	"	23.10
" 2—9 " " " 25 " " "	"	26.40

Inspection, \$0.30 each. For Price of Weights, see page 738.

DISPENSING SCALE



No. 6

No. 6—3½ inch Pans, Capacity 4 oz.....each \$12.00

Scale for rough prescription work, has 3½ inch nickel-plated movable pans, a side-beam in front of scale with a sliding weight; this beam is divided into 120 divisions, each division representing one grain; an extra row of metric divisions is placed on bottom edge of beam, each representing one decigram. Platform or shelf is attached to base of scale in which are fitted a set of solid brass Troy weights, 2 oz. and down. Scale sensible to ½ a grain.

LABORATORY SCALE

For Accurate Weighing.



No. 7

No. 7—6 inch Pans, Capacity 1 lb.....each \$13.50

Scale specially designed for laboratory and pharmaceutical work, has six-inch nickel pans, which are movable. Scale will carry one pound in each pan, is sensible to a ¼ grain, has a full set of weights running from 6 oz. Troy and down to 1 grain; these are neatly fitted in a projecting shelf attached to the base of scale. Metric weights furnished in place of Troy when so desired.

GEM TOBACCO SCALE



No. 12

Length of Base, 10 inch. Size of Scoop, 7 x 3½ inch.

No. 12—Capacity 8 oz.....each \$10.50
Inspection, \$0.20 each.

This scale is adapted for weighing tobacco, lozenges, bon-bons, etc.; is small, light and ornamental. Brass scoop and weight plate. Provided with a set of solid brass weights 4 oz. and down, which are neatly fitted separately in a platform attached to the base of scale.

CANDY SCALE



No. 16

No. 16—Capacity 1 lb.....each \$12.00
Inspection, \$0.20 each.

Specially made for retail druggists for weighing out candy, cough drops, etc. Weighs to one pound, notches on beam quarter ounces, nickel-plated, movable scoop, etc. Scale requires no weights and is mounted on a polished oak base.

AVERY'S AGATE BALANCES



No. 940

Japanned and Gilt Beam, with Patent Agate Bearings,
Patent Iron Jointed Crank, Brass Chains.

Length of Beam.....	12	14	16	inch.	
Capacity.....	4	7	10	lbs.	
With Brass Pan, Polished.....	each	\$6.40	7.20	8.40	
" Scoop, " " " "		7.00	8.40	9.60	



No. 4172

Japanned and Gilt Beam, Iron Crank, Steel Bearings,
Brass Chains.

Length of Beam.....	12	14	inch.	
Capacity.....	4	7	lbs.	
With Brass Pan, Polished.....	each	3.80	4.20	
" Scoop, " " " "		4.50	5.00	



No. 923

Japanned and Gilt Wrought Iron Pillar, Brass Patent Agate Beam, Brass Jointed Crank, Brass Links.

Length of Beam.....	14	16	18	inch.	
Capacity.....	4	7	10	lbs.	
With Brass Pan, Polished, without Weights.....	each	\$18.40	20.80	24.40	
" Scoop, " " " "		19.20	22.40	25.60	

Inspection, 4 lbs. \$0.20, 7 to 10 lbs. \$0.30 each.

Priced without Weights, For Price of Weights, see Page 730.

AVERY'S AGATE BALANCES



No. 926

Japanned and Gilt Ornamental Iron Pillar with Brass Stem, Brass Patent Agate Beam, Brass Jointed Crank, Weight and Links.

Length of Beam.....	14	16	18	inch.
Capacity.....	4	7	10	lb.
With Brass Pan, Polished, each	\$16.80	20.40	24.00	
Scoop " " "	18.00	22.40	26.80	

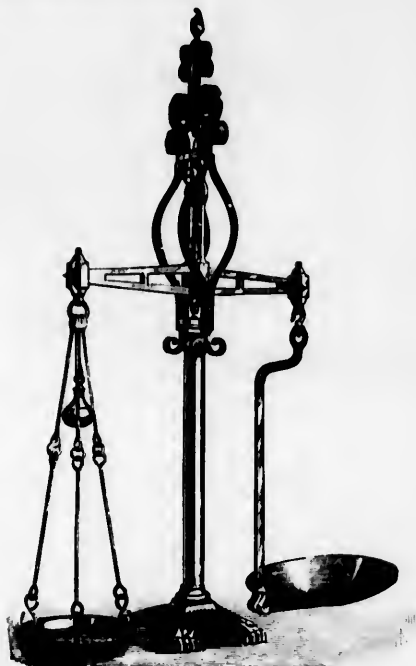

No. 927

Japanned and Gilt Ornamental Iron Top, Brass Stem, Brass Patent Agate Beam, Brass Jointed Crank, Weight and Links.

Length of Beam.....	14	16	18	inch.
Capacity.....	4	7	10	lb.
With Brass Pan, Polished, each	\$23.20	26.80	30.80	
Scoop " " "	24.80	28.80	33.60	

Inspection, 4 lb. \$0.20, 7 to 10 lb. \$0.30 each. Priced without Weights. For price of Weights see page 739.

BLOCK WEIGHTS



No. 231

TROY

	per set	Brass.
5 ounce to 1/2 grain		\$ 4.15
10 " " "		6.00
20 " " "		11.55
30 " " "		14.85
50 " " "		20.65
100 " " "		29.70
200 " " "		44.55
500 " " "		84.15

AVOIRDUPOIS

Solid Brass, in Walnut or Cherry Block, as No. 231.

	per set	Brass.	Nickel Plated.
1 lb. to 1/2 ounce.....		\$3.70	4.95
2 " " "		5.75	7.45
4 " " "		8.25	10.75

CUP WEIGHTS



No. 138

TROY

	per set	Brass.
64 ounce to 1/2 ounce		\$14.85
32 " " "		9.10
16 " " "		6.00
8 " " "		4.95
4 " " "		2.50
10 Pennyweights to 1/2 grain		0.85
1/2 " " "		0.40

AVOIRDUPOIS

Solid Brass, in Oiled Walnut Block Lined with Poplar. Weights Burnished, as No. 231.

	per set	Brass.	Nickel Plated.
1 lb. to 1/2 ounce.....		\$ 6.00	8.25
2 " " "		9.10	10.75
4 " " "		11.55	14.00

Weight
Bell S
Nest

Weight
Bell S
Nest

Weight
Nest S

Weight
Nest S

For
These w
standar

1 Pl
10 gr
20
2 20-
50 gra
100
200
500
1000

10 Pla
10
100 Gra
1000 "
1000 "
1000 "

BRASS AND IRON WEIGHTS

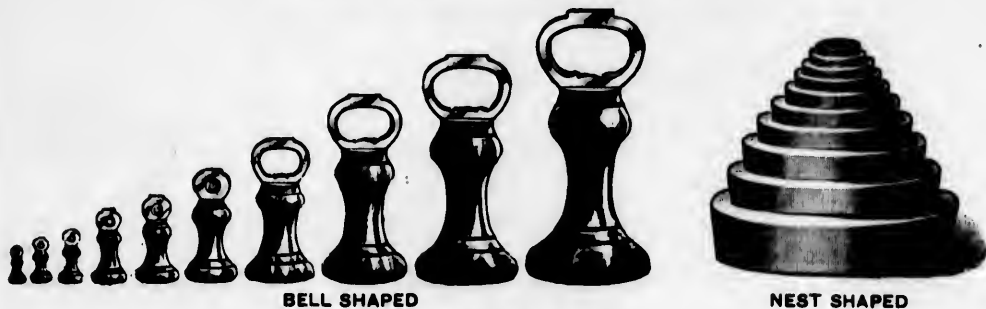

BRASS WEIGHTS, IN SETS

Weights.....	1/4 oz. to 1/2 lb.	1/4 oz. to 1 lb.	1/4 oz. to 2 lb.	1/4 oz. to 3 lb.	1/4 oz. to 4 lb.	1/4 oz. to 5 lb.
Bell Shaped.....per set	\$1.80	2.30	3.75	5.75	8.50	11.75
Nest "....."	1.00	2.00	4.10	6.20	9.00	12.90

BRASS WEIGHTS, SEPARATE

Weights.....	1/4	1/2	1	2	4	8 oz.	1	2	3	4	5 lb.
Bell Shaped.....each	\$0.25	0.25	0.25	0.30	0.35	0.55	0.90	1.00	2.10	3.00	3.70
Nest "....."	0.20	0.20	0.20	0.25	0.30	0.50	0.80	1.50	2.00	2.80	3.50

IRON WEIGHTS, IN SETS

Weights.....	1/2 oz. to 1/2 lb.	1/2 oz. to 1 lb.	1/2 oz. to 2 lb.	1/2 oz. to 3 lb.	1/2 oz. to 4 lb.	1/2 oz. to 5 lb.
Nest Shaped.....per set	\$0.75	1.00	1.25	1.50	1.90	2.30

IRON WEIGHTS, SEPARATE

Weights.....	1/2	1	2	4 oz.	1/2	1	2	3	4	5 lb.
Nest Shaped.....each	\$0.13	0.13	0.13	0.13	0.25	0.25	0.35	0.45	0.55	0.65

Inspection, \$0.05 for each Weight.

WEIGHTS OF PRECISION



No. 13B



No. 24

For analytical, assaying and scientific purposes. These weights are warranted to be of the very highest standard of accuracy and precision.

1	Platinum	gramme down to 1/10 milligramme	Per set.	\$14.00
10	gramme	pieces down to 1 milligramme		15.70
20	"	" " " " " 3 " "		18.15
20	20-	gramme " " " " and 3 riders		19.80
50	gramme	" " " " " 3 " "		23.10
100	"	" " " " " 3 " "		26.40
200	"	" " " " " 3 " "		30.55
500	"	" " " " " 3 " "		37.05
1000	"	" " " " " 3 " "		46.20

TROY GRAINS

10	Platinum	grains to 1/100 grain	14.00
10	"	" " " " " 1/100 " "	15.70
100	Grain	piece down to 1/100 grain	16.50
1000	"	" " " " " 1/100 " and 3 riders	19.80
1000	"	" " " " " 1/100 " " "	21.45
1000	"	" " " " " 1/100 " " "	23.10

For pharmaceutical, chemical and other accurate purposes.

In polished mahogany box, velvet lined; large weights are lacquered, the small ones are of aluminum.

20	gramme	down to 1 centigramme	Per set.	\$ 5.80
50	"	" " " " " 1 " "		8.25
100	"	" " " " " 1 " "		10.00
500	"	" " " " " 1 " "		16.50
500	"	" " " " " 1 milligramme		19.80
1	kilogramme	down to 1 gramme		19.50
1	"	" " " " " 1 centigramme		19.80
1	"	" " " " " 1 milligramme		23.10
1	ounce	Troy " " " grain		5.80
2	"	" " " " " " " "		8.25
5	"	" " " " " " " "		12.40
10	"	" " " " " " " "		16.50
20	"	" " " " " " " "		21.45
50	"	" " " " " " " "		28.00
100	"	" " " " " " " "		42.90

COFFEE AND SPICE MILLS

ENTERPRISE



No. 0



SHOWING N° 1 MILL CLOSED.



SHOWING N° 1 MILL OPEN.

No. 1

No. 0—Hopper holds 4 ounces, Weight 6 lbs., Height 11½ inches.....each \$2.25
 " 1— " " " 10 " " 12½ " " " " 3.40



IRON HOPPER



NICKEL-PLATED HOPPER

No. 2—Iron Hopper holds 4 ozs., Weight 15 lbs., Height 12½ inches.....each 5.25
 " 3— " " " 8 " " 22½ " " 15 " " " 7.50
 " 9— " " " 3 lbs., " 107 " " 24 " " " 24.00
 " 2½—Nickel-Plated Hopper holds 7 ozs., Weight 14 lbs., Height 15 inches..... " 6.75
 " 4— " " " 1 lb., " 22 " " 20½ " " " 12.00
 " 10— " " " 4½ lbs., " 102 " " 28 " " " 31.50

Nos. 2 and 2½ will grind 6 ozs. per minute, Nos. 3 and 4, half lb., Nos. 9 and 10, 1½ lbs.

ENTERPRISE COFFEE, SPICE AND DRUG MILLS

No. 12—Iron Hopper, holds 5 lbs. coffee, Height 32 inches, Wheels 25 inches diam., Weight 141 lbs, will grind 1½ lbs. of coffee per minute, Cast Iron Base with Removable Receiving Cup.....each 33.00
 " 14—Nickel-Plated Hopper, holds 7½ lbs. coffee, Height 42 inches, Wheels 25 inches diam., Weight 128 lbs., will grind 1½ lbs. of coffee per minute, Cast Iron Base with Removable Receiving Cup.....each 40.50
 " 16—Iron Hopper, holds 6½ lbs., Height 5 feet 3 inches, Wheels 31 inches diam., Weight 250 lbs., will grind 1½ lbs. of coffee per minute, stands on Ornamental Cast Iron Base.....each 60.00
 " 18—Nickel-Plated Hopper, holds 7½ lbs. coffee, Height 5 feet 3 inches, Wheels 31 inches diam., Weight 233 lbs., will grind 1½ lbs. of coffee per minute, stands on Ornamental Cast Iron Base.....each 67.50

Mills Nos. 9 to 18 are fitted with Enterprise New "Rapid" Grinders, which will pulverize. Nos. 12 to 18 Mills to order only.

No. 1
 " 10

No. 300
 " 301
 " 400

COFFEE AND SPOICE MILLS

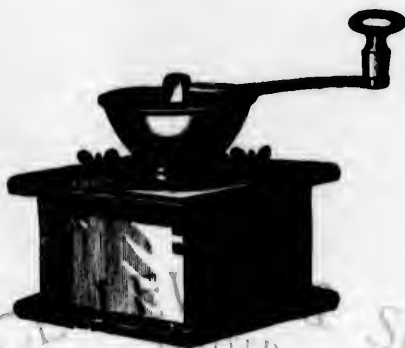

Nos. 104 and 106

No. 104—Box Coffee or Spice Mills, Iron Hopper, with Dovetailed Boxes	per doz.	\$0.75
" 106— " " " Britannia Hopper, " "	" "	0.00



Nos. 300 and 301



No. 400

No. 300—Box Coffee or Spice Mills, Wood Top, with Dovetailed Boxes, Small Size	per doz.	8.10
" 301— " " " " " " " " Medium "	" "	9.00
" 400— " " " Iron " Bronzed, " " " Small "	" "	8.10

Half dozen in a box.



OPEN.

each \$2.25
" 3.40

each 5.25
" 7.50
" 24.00
" 6.75
" 12.00
" 31.50

will
each 33.00
lbs.,
each 40.50
will
each 60.00
light
each 67.50
2 to 18 Mills

CHERRY STONERS

ENTERPRISE CHERRY STONER



No. 1—Japanned per doz. \$10.60
 " 2—Tinned " 13.50

Can be adjusted by Thumb Screws to adapt it to the different sizes of cherry stones. Is recommended particularly to those desiring rapid work.

NEW CHERRY STONER



No. 12—Tinned per doz. \$18.00

No. 12 is intended to stone cherries with the least possible cutting or disfiguring. The most satisfactory results are obtained by dropping the cherries one at a time, into the hopper immediately after sweeper has passed the hole.

RAISIN AND GRAPE SEEDERS

ENTERPRISE RAISIN SEEDER



No. 36—Size for Families per doz. \$15.00
 " 38— " Hotels, Bakeries, etc... " 45.00
 No. 36 will seed a pound of raisins in five minutes;
 No. 38, a pound in one minute.

CROWN RAISIN SEEDER



No. 37—Crown Raisin Seeders per doz. \$11.40

Seeds one pound of raisins in five minutes.

FRUIT AUGERS

No. 1—Malleable Iron, Tinned, with Wood Handle,
 per doz. 9.00

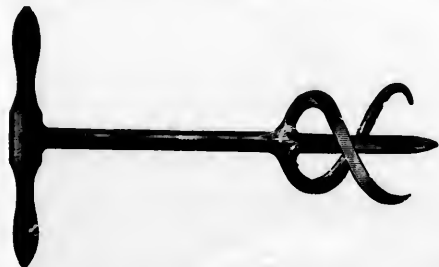

er doz. \$0.75
 " 7.35
 " 9.00
 " 20.25
 " 4.05

ah, etc.

Price each.
 \$3.50
 7.00
 10.50

The Burrs are
 shel per hour:

CE PRESS



NGE CLAMP

ROTARY NUTMEG GRATER

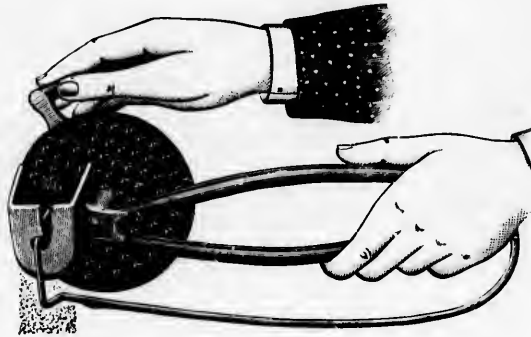

No. 1—Rotary Nutmeg Graters, Tinned..... per doz. \$1.80

BREAD GRATERS



CHAMPION



No. 1050A

Champion —With Rotary Disc, Tinned..... per doz. 18.00
 No. 1050A— “ Revolving Tinned Disc, Enamelled Inside, Painted Frame..... “ 18.00

These Machines will grate cocoanut, walnuts, almonds, crackers and all similar substances.

SMOKED BEEF SHIVERS

ENTERPRISE



No. 125

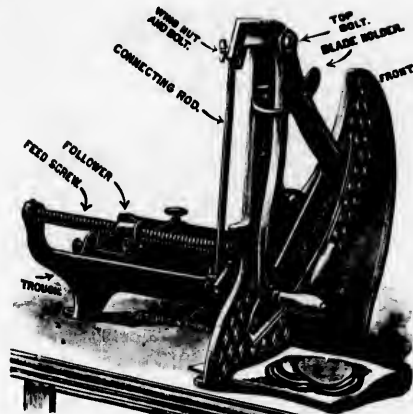

No. 23

- No. 125—New Rotary Beef Shaver. The sliced beef falls into a drawer which holds about two pounds. Easy to regulate each \$27.00
 No. 23—Improved Beef Shaver, Japanned, with Swing Blade, Automatic Feed " 9.75

Size
Ent
Pric

MEAT AND FOOD CHOPPERS

TINNED

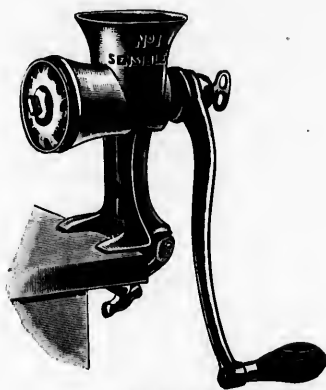

SENSIBLE



IDEAL

- No. 1—Sensible, cuts 1½ lbs. meat per minute..... each 1.95
 " 2- " " 2 " " " 2.50
 " 25—Ideal " 2 " " " 2.50

No.
"
"
"

These Machines are suited for different uses and will cut meat, fruit, vegetables, crackers, cheese, etc. All parts Tinned.

that

ALEXANDERWERK MEAT CHOPPERS

WHITE ENAMELLED INSIDE, JAPANNED AND ORNAMENTED OUTSIDE



Size.....	R	S	SS	U	T
Enterprise Nos.....	5	10	12	22	32
Price.....each	\$1.50	2.25	1.88	3.00	4.50

AMERICAN MEAT CHOPPERS

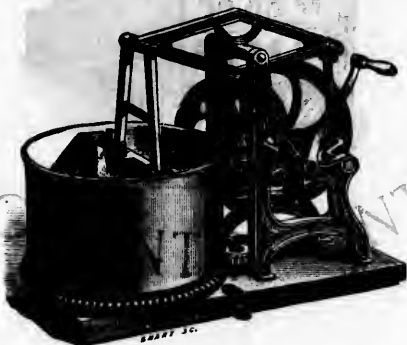

Nos. 1 to 4

No. 1—Family size, 8 inch Cylinder, cuts 3 lbs. in 3 minutes, Weight 14 lbs.....	each	\$ 6.25
“ 2— “ “ 10 “ “ “ 5 to 6 lbs. in 3 minutes, Weight 21 lbs.....	“	8.75
“ 3—Hotel “ 12 “ “ “ 8 to 10 “ in 3 “ “ 37 lbs.....	“	12.50
“ 4—Butcher “ 15 “ “ “ 50 to 60 “ an hour, Weight Crated 120 lbs.....	“	31.25
“ B— “ “ 20 “ “ “ 80 to 100 “ “ “ 275 lbs.....	“	62.50

No. 4 is especially adapted for the use of Butchers. No. B is in all respects similar to No. 4, with the exception that it is mounted on legs and the cylinder is 5 inches larger in diameter.

ENTERPRISE MEAT CHOPPERS

TINNED

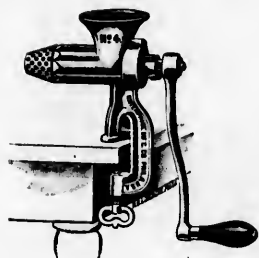

Nos. 2 and 4



Nos. 5 and 10

No. 2—Chops 1 lb. per minute, weight 4½ lbs.....	each	\$1.75
“ 4— “ 1½ “ “ “ 5½ “	“	2.25
“ 5— “ 1 “ “ “ 4½ “	“	2.00
“ 10— “ 2 “ “ “ 8 “	“	3.00

Six in a case.



Showing Machine taken apart.

Nos. 12, 22 and 32

No. 12—Chops 2 lbs. per minute, weight 7 lbs.....	each	2.50
“ 22— “ 3 “ “ “ 12 “	“	4.00
“ 32— “ 4 “ “ “ 18 “	“	6.00

Six in a case.

PRICES OF PARTS FOR ENTERPRISE MEAT CHOPPERS

Nos.....	5	10	12	22	32	
Plates.....	each	\$0.30	0.50	0.50	0.75	1.00
Knives.....	“	0.25	0.30	0.30	0.50	0.75
Rings.....	“	0.25	0.40	0.40	0.75	1.00
Handles.....	“	0.25	0.30	0.30	0.50	0.75

that
block
med
beef
thro

No. 4
“ 4

No. 4

16½ in
Pulle

MEAT CHOPPERS

TINNED

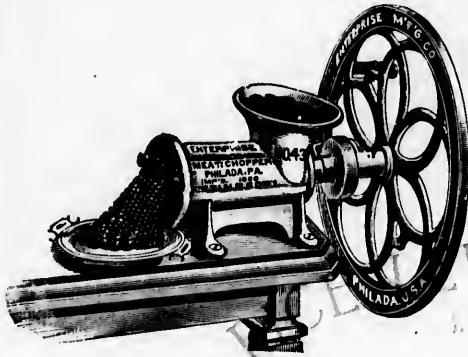

No. 43



No. 44

No. 43 is similar in construction to No. 44, the only difference being that it has no Column or Pedestal, and is intended to be screwed to a table or block. Four Plates are sent with each Machine, two fine ($\frac{7}{8}$ in. holes), one medium ($\frac{1}{2}$ in. holes), and one coarse ($\frac{3}{8}$ in. holes), also four Knives. In cutting beef it should be run through the coarse Plate first (slow speed), and then through the fine Plate.

No. 43—Diameter of Plate $5\frac{1}{2}$ inches, Diameter of Fly Wheel 31 inches.....	each	\$45.00
" 44— " " " $5\frac{1}{2}$ " " " " " 31 "	"	60.00

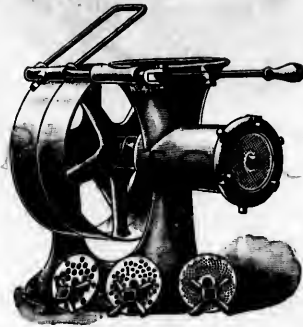

No. 41

No. 41—Capacity 300 lbs. of beef per hour, furnished with four Plates and Knives	each	50.00
--	------	-------

The Plates furnished with this Machine, are two $\frac{7}{8}$ in. holes, one $\frac{1}{2}$ in., and one $\frac{3}{8}$ in., also four Knives. Height $16\frac{1}{2}$ inches, Length 21 inches, Diameter of Hopper 9 inches, Diameter of Throat 3 inches, Diameter of Plate 4 inches, Pulleys $12 \times 2\frac{1}{2}$ inches, Power 1 to 3 h.p., Weight of Machine complete 93 lbs.

SAUSAGE STUFFERS

TINNED STEEL CYLINDERS, CASTINGS MALLEABLE IRON

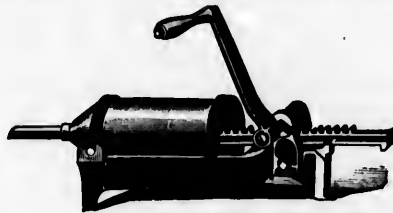

Nos. 1 and 2

No. 1—Capacity 6 lbs., Weight (crated) 30 lbs.	each	\$5.00
" 2— " 9 " " 40 "	"	8.00

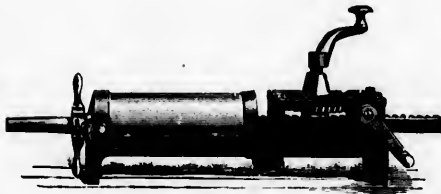

No. 3



No. 4

No. 3—Capacity 12 lbs., Weight (crated) 80 lbs.	each	\$10.00
" 4— " 18 " " 120 "	"	15.00

SAUSAGE STUFFER AND LARD PRESS



SCREW MOVEMENT



RACK MOVEMENT



STUFFING ATTACHMENT

No. 5—Rack Movement, Cap. 2 qts., Japanned	each	\$4.50
" 15—Screw " " 2 " "	"	6.00
" 25— " " " 4 " "	"	7.50
" 35— " " " 8 " "	"	9.75

STUFFING ATTACHMENT FOR ENTERPRISE MEAT CHOPPERS

To fit Choppers Nos.	5	10	12	22	32	
$\frac{3}{4}$ inch	per doz.	\$3.75	4.50	4.50	6.00	7.25

The Stuffing Attachment, illustrated above, may be attached to the Enterprise Meat Choppers. After the meat has been chopped, remove the Knife and Plate, and place against the Cylinder. They are made of spun brass nickel-plated.

BUTCHERS' CLEAVERS



No. 3702

Cut	6	7	8	9 inch.
No. 3702—Boker's, Heavy Beechwood Handle. per doz.	\$5.25	0.40	7.00	0.00

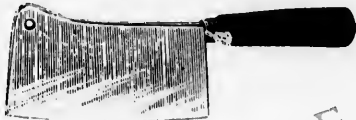

No. 3700



No. 3706

Cut	6	7	9	10	12 inch.
No. 3700—Boker's, Plain Black Handle	\$3.75	4.15
" 3706— " Round Beechwood Handle	17.00	20.50
" 3715— " Riveted " Heavy Blade, Pattern as 3700	27.25	33.00	45.00

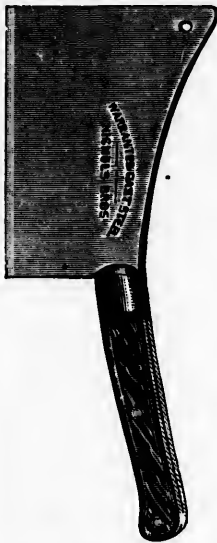

MARKET CLEAVER



PORK CHOPPER



LAMB CLEAVER



BEEF SPLITTER

Cut	7	8	9 inch.
Market Cleaver	per doz. \$18.00	21.45	25.20
Cut	8	9	10 inch.
Pork Chopper	per doz. \$17.00	19.55	22.05
Cut	8	9	inch
Lamb Cleaver	per doz. \$12.00	13.85	
Cut	12	14	inch.
Beef Splitter	per doz. \$52.65	60.75	

CLOTHES WRINGERS



RIVAL, BALL BEARINGS



CRESCENT

Rival, Ball Bearing, Rolls Vulcanized on the Shaft, Size 10 x 1 $\frac{1}{4}$ inch	per doz.	\$35.50
Crescent, Double Gear, " " " " " 10 x 1 $\frac{1}{4}$ "	"	33.00

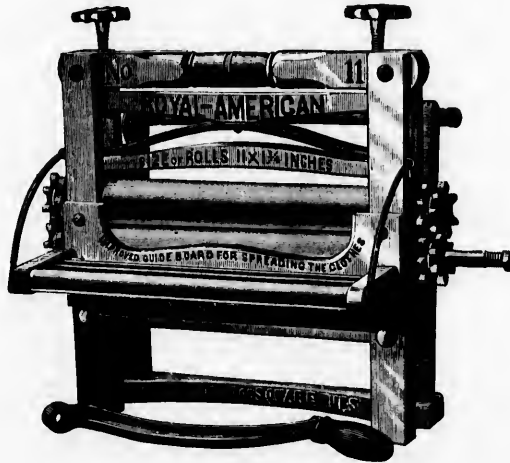

ROYAL AMERICAN

Royal American, with Patent Adhesive Rolls, Vulcanized on the Shafts, Size 11 x 1 $\frac{1}{4}$ inches	per doz.	41.25
--	----------	-------

Le
XX

Ajax

CLOTHES WRINGERS

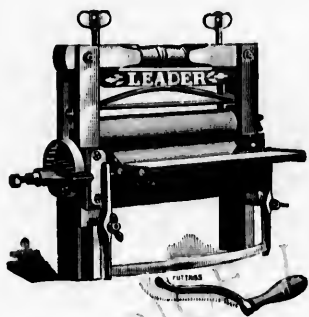

LEADER

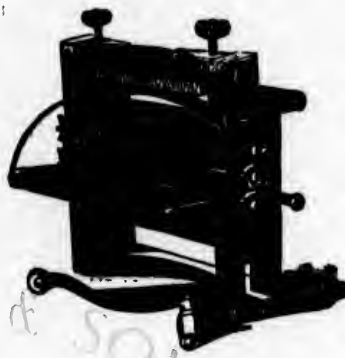

XXX ROYAL CANADIAN

Leader, with Internal Gear, Lever Tightener, Rolls 11 x 14 inches.....per doz. \$45.00
XXX Royal Canadian, Double Gear, Iron Bearings, Rolls 11 x 14 inches..... " 13.50



AJAX

Ajax, Heavy, suitable for Hotels and Laundries, Rolls 14 x 24 inches.....per doz. 108.00

41.25

\$55.50
33.00

WASHING MACHINES

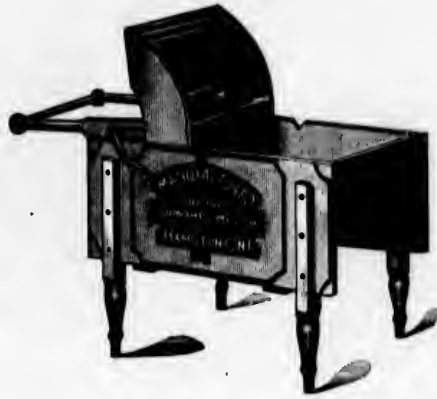

DOWSWELL

Dowsell Clothes Washing Machines.....	each	\$4.50
Jubilee " " "	"	1.15

MANGLES

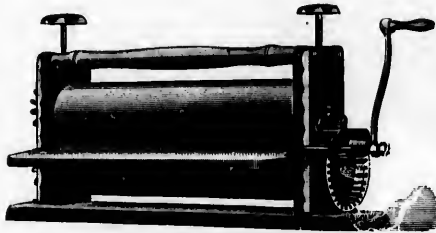

DOMESTIC



THREE ROLLER MANGLE

Domestic, 2 Maple Rolls, 20 inches long, 4 inches diam., Driven by Internal Gear, easy to operate.....	each	9.00
Queen, 3 Maple Rolls, 24 inches long, 5 inches diam., Mounted on Iron Wheels, Heavy Frame, Folding Wood Table on one side.....	each	18.75
Turner's, 3 Maple Rolls, 24 inches long, 5 inches diam, Mounted on Iron Wheels, Heavy Frame, Folding Wood Table on one side.....	each	24.00

No. 50
" 55
Extra

Sad Iron
No. 182
" 282
" 82
" 87
" 72
" 77

Tailors' I

CARPET BEATERS



No. 902

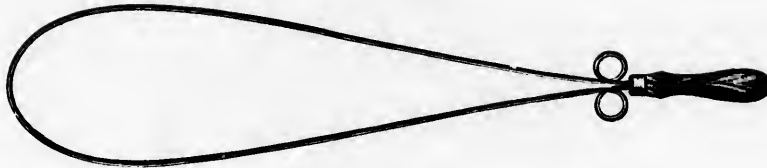

No. 2

No. 902—Double Cane, Extra Strong.....	per doz.	\$3.40
" 2—Steel Wire, Coppered, Wood Handles.....	"	1.45

CARPET STRETCHERS



No. 5

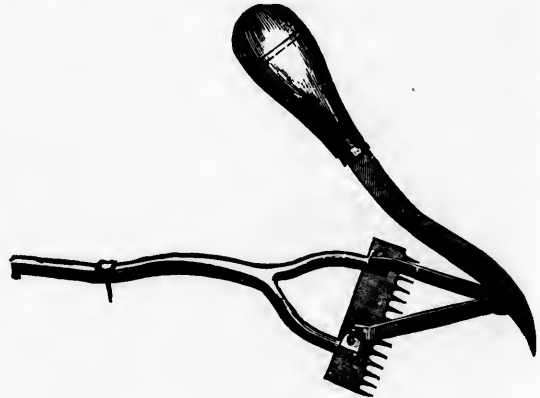

No. 6

No. 5—4½ inch, Polished Steel Blade and Points, Japanned.....	per doz.	1.15
" 6—Bullard's Patent, Polished Steel Blade, Japanned Iron Frame, Wood Handle.....	"	7.15

CARPET SWEEPERS

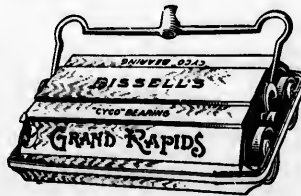

Grand Rapids, with Rubber Bands, Japanned Trimmings.....	per doz.	31.00
" " Hall Sweeper, Suitable for Hotels.....	"	08.00
Rubber Bands for Grand Rapids Carpet Sweepers.....	"	3.00

Extra
Trojan
Will
Peer



WILL

Nos...
Size...
Clothes

Size...
Root, U

MOP STICKS.

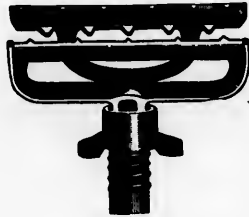

Extra Star.....	per doz.	\$2.00	Self-Wringing Mops.....	per doz.	\$6.00
Trojan.....	"	3.00	" " "Cloths, extra.....	"	2.50
Williams'.....	"	3.00			
Peerless (similar to Williams').....	"	2.50			



CLOTHES PINS

Selected, full count.

No. 1-5 gross in box.....	single box	1.30
" 1-5 " ".....	10 box lots	1.10
Extra Star in 4 doz. packages, 12 packages to a case.....	per case	1.50
" " 6 " " 12 " ".....	"	2.00
Hoyt's Patent Spring Clothes Pin, 5 gross in a case.....	"	3.00

BASKETS



WILLOW CLOTHES BASKETS



WILLOW ROOT BASKETS



SPLINT ROOT BASKETS

WILLOW BASKETS

Nos.....	1	2	3
Size.....	30x22x13	27 1/2x12	25x18-12 inch.
Clothes, Oval, per doz.	\$13.00	12.00	12.00
Size.....	1	1 1/2	2 bush.
Root, Unpeeled Willow, per doz.	\$8.50	11.00	13.00

SPLINT BASKETS

	Large.	Medium.	Small.
Size.....	30x21x12	25x17x10	25x17x8 inch.
Clothes... per doz.	\$5.50	5.00	4.50
Size.....	1	2	3 bush.
Root..... per doz.	\$3.80	7.00	11.50

WOODENWARE

BUTTER BOWLS

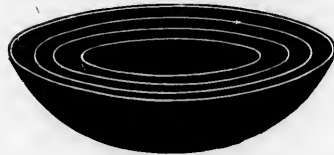

Size.....	13	15	17	19	21	24
Maple... per doz.	\$1.90	4.00	6.00	8.00	10.00	17.00
Assorted, 4 in a Crate (Nos. 13, 15, 17, 19) . . . per doz.	6.00					

CHOPPING TRAYS



Nos.....	1	2	3	4
Maple... per doz.	\$6.00	8.00	10.00	15.00
Assorted, 4 each (Nos. 1, 2, 3)..... per doz.	8.00			

BUTTER LADLES



Nos.....	1	2	3
Per dozen.....	\$1.50	1.30	1.10

DRY MEASURES



WOOD

Size.....	½	1	2 pecks.
Per dozen.....	\$3.25	4.50	7.50

Inspected.



IRON, JAPANED

Size.....	¼	½	1	2 pecks.
Per dozen.....	\$3.18	3.87	7.18	8.43

Inspected.

Feed Pans, Iron, Japanned, 5½ inches deep, 8 inches diam..... per doz.	\$1.87
Feed Boxes, Wood, 6½ inches deep, 10½ inches diam.....	1.50

No. 2
" 2
" 2

No. 29
" 29
" 29

Size...
No. 280
" 277
" 282

No. 283

Size...
No. 299

WOODENWARE

ROLLING PINS



No. 293 —Solid Handles.....	per doz.	\$1.30
" 293R—Revolving Handles.....	"	1.40
" 293E—Enamelled Handles.....	"	1.00

POTATO MASHERS



No. 294 —Straight Pattern.....	per doz.	0.80
" 294S—Shaped ".....	"	0.90
" 294E—Enamelled Handles.....	"	1.10

BUTTER MOULDS

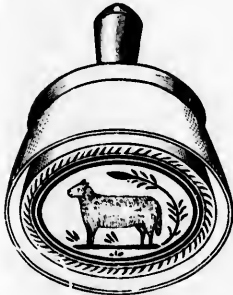

No. 280



No. 282



No. 277

Size.....		1/4	1/2	1	2 lbs.
No. 280—Best White Wood, Assorted Patterns.....	per doz.	\$3.70	5.00	7.50
" 277— " Seasoned Maple, with adjustable Screws.....	"	0.00	7.50	9.00	10.50
" 282—Butter Stamps, 3 to 4 inch.....	per doz.				\$1.20

BUTTER SPADES



No. 283—Fluted.....	per doz.	1.70
---------------------	----------	------

WOODEN SPOONS



Size.....		12	15	18	inch.
No. 299—Straight Handle.....	per doz.	\$1.00	1.30	2.00	

3 4
0.00 15.00
doz. 8.00

3
1.10

2 pecks.
8.43

oz. \$1.87
1.50

STEP LADDERS AND WASH BOARDS

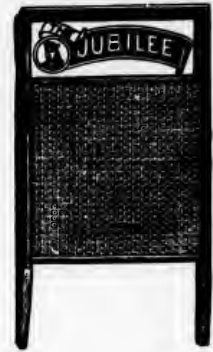

STEP LADDERS

Length	5	6	7	8	10 feet.
Each	\$0.80	1.00	1.12	1.28	1.60

WASH BOARDS

Leader Globe, Thin Back, Light Zinc, Improved Tops.....	per doz.	\$2.50
Improved " " Heavy " " "	"	2.80
Standard " Thick Back, " " "	"	3.00
Solid " Solid One Piece Back, Heavy Zinc, Improved Tops.....	"	3.20
Jubilee, Perforated Zinc, Oval Face.....	"	3.80
Jewel, Extra Quality, Heavy Zinc, Double Face, Reversible Top.....	"	7.80
Superb " " " " " Improved Top	"	7.80

Half-dozen in a crate.

WHEEL HEADS



ANTI-FRICTION

Large..... per doz. \$8.00

DASHER CHURNS

Size	6	8	10 gals.
No. 285—Oak .. per doz.	\$24.00	27.00	30.00



No. 1
" 2
" 3
" 4



Size ..
Gem ..
Lightn ..

CHURNS

WITH ROLLER BEARINGS



LEADER



DAISY

LEWIS & CO. LIMITED

No. 1— 9 Gals., Churns from 1 to 4 Gals..... each	\$8.50	No. 0— 7 Gals., Churns for 1 Cow..... each	\$8.00
" 2—15 " " " 1 " 7 " " " " "	9.00	" 1— 9 " " " from 1 to 4 Gals..... "	8.50
" 3—20 " " " 1 " 9 " " " " "	10.00	" 2—15 " " " 1 " 7 " " " " "	9.00
" 4—25 " " " 1 " 12 " " " " "	12.00	" 3—20 " " " 1 " 9 " " " " "	10.00
		" 4—25 " " " 1 " 12 " " " " "	12.00

10 feet.
1.60

doz. \$2.50
2.90
3.00
3.20
3.80
7.80
7.80

ICE CREAM FREEZERS



GEM



LIGHTNING

Size	2	3	4	6	8	10	14 quart.
Gem	\$2.10	2.55	2.95	3.75	5.05	6.75	9.50
Lightning.....	2.10	2.55	2.95	3.75	5.05	6.75

ICE PICKS



No. 1—Steel Blade, Hardwood Handle.....per doz. \$1.05



No. 3—Steel Blade, Hollow Iron Head.....per doz. 2.85



No. 2—Tempered Steel Blade, Hardwood Head with Galvanized Iron Ringper doz. 4.00



Alaska Ice Breaker and Shaver, Nickel-Plated, Japanned Striker.....per doz. 4.00

CROWN ICE CHIPPER



Crown Ice Chipper, Wood Handle, Polished Steel Blade, Galvanized Iron Guardper doz. 8.25

Length over all 10 inches.

No. 33

No. 43

No. 1—H
 " 2—M
 " 3—I
 " 31—
 " 32—M
 " 31—F

ICE SHREDDERS

ENTERPRISE



No. 33—Tinned, for Shaving Ice, Coarse or Fine per doz. \$9.00



No. 43—Tinned, for Shaving Ice, Coarse or Fine per doz. 13.50

ICE TONGS



Nos. 1 to 3



Nos. 21 and 22

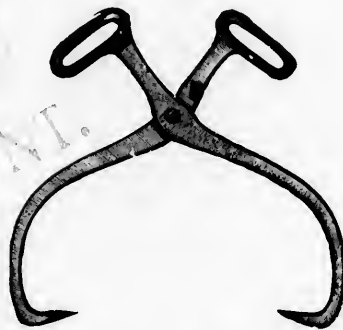

No. 31

No. 1—Heavy, for Packing Houses and Delivery Wagons, open 21 inches.....	per doz.	12.00
" 2—Medium, for Stores, Hotels, Private Houses, etc., " 18 "	"	9.00
" 3—Light, Small Tongs, suitable for Private Houses, " 11 "	"	6.00
" 21—" " " " " 11 "	"	6.60
" 22—Medium, for Stores, Hotels, etc., open 16 inches.....	"	7.70
" 31—Family Ice Tongs, Malleable Iron, Japanned, open 12 inches.....	"	6.00

EGG BEATERS



No. 2



No. 20



No. 100



No. 10

No. 2—Keystone Egg Beater and Cream Whip.....	per doz.	\$11.05
" 20— " " " with Graduated Glass Jar, holds 1 qt. (Wine).....	"	19.15
" Extra Jars	"	6.00
" 100—Improved Dover Pattern Egg Beaters	"	2.00
" 10—Batter Mixers, Flat Steel Wire	"	3.00

FLOUR SIFTERS

BALLOON FLY TRAPS

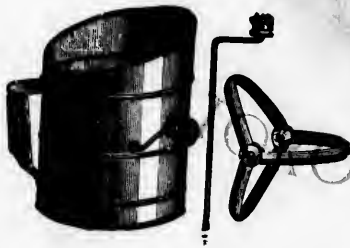

Victor Flour Sifters.....	per doz.	\$2.20		Balloon Fly Traps	per doz.	2.70
---------------------------	----------	--------	--	-------------------------	----------	------

CORN POPPERS



Corn Poppers	per doz.	1.60
--------------------	----------	------

CAN OPENERS



No. 990—Sardine Scissors, Length 7 $\frac{1}{2}$ inches, Bright, with Catch per doz. \$3.25
 " 6821—Lund's Can Opener, " 7 $\frac{1}{2}$ " Bronzed, " " 8.75



No. 5—Steel Blade, Japanned Handle per doz. 0.45



Double Quick, Cold Rolled Steel Blade, Tinned Malleable Iron Handle per doz. 0.85



No. 2—Sprague's, Steel Blade, Double Slide, Wood Handle per doz. 0.90
 " 991A—Boker's, " " Varnished Wood Handle 1.00
 6491— " Fine " " " Nickel-Plated " 1.50

CHAMPAGNE NIPPERS

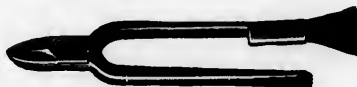

No. 521—5 inch, Polished per doz. 7.50

\$1.00

0.75
2.25

3.00
3.00
out

OYSTER OPENERS



No. 987

No. 987—Wood Handle, Plain, Polished Blade per doz. \$1.25

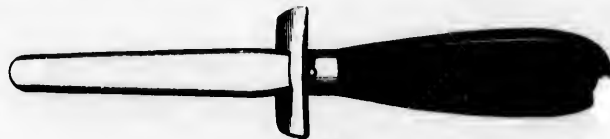

No. 6604

No. 6604—Black Wood Handle, with Guard, Polished Blade, Length 7½ inches per doz. 4.00
 " 6604—Stag Horn " " " " " " 7½ " " 5.00

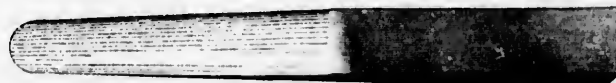

No. 990

No. 990—All Metal, Polished Blade, Length 8 inches per doz. 4.10



No. 6820

No. 6820—Patent Oyster Opener, Length 8 inches per doz. 7.00



No 1759

LARDING PINS



No. D538—In Tin Case containing 1 dozen, with Trussing Needle per doz. cases 11.00

SKEWERS

No. 1759—Steel Skewers, 12 Assorted, 4 to 8 inch per doz. set 1.50

BAR SUPPLIES



No. 50. Full size cut.

No. 50—Spice Box, Nickel-Plated	per doz.	\$18.00
" 60— " " Bottle Shape	"	18.00



No. 55



No. 65

No. 55—Mineral Glass Holder, Nickel-Plated, with Spring Band	per doz.	4.30
" 65—Soda Glass Holder, Silver-Plated on Nickel-Silver	"	18.00

BAR SUPPLIES

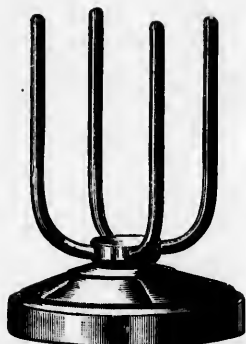

GINGER ALE BOTTLE HOLDER



SPUN SHAKER



LIQUOR JIGGER. Full size cut.

No. 10—Ginger Ale Bottle Holders, Nickel Silver	per doz.	\$8.65
" 2—Tin Shaker, Flaring, Mouth $3\frac{1}{2}$ inches Diameter, Length $5\frac{1}{2}$ inches	"	2.00
" 3— " " " " $3\frac{1}{2}$ " " " " $5\frac{1}{2}$ " " " "	"	2.00
" M—Spun Copper Shakers, Nickel-Plated, Mouth $3\frac{1}{2}$ inches Diameter, Length $5\frac{1}{2}$ inches	"	12.25
" C— " " " " $3\frac{1}{2}$ " " " " $5\frac{1}{2}$ " " " "	"	14.40
" D— " " " " $3\frac{1}{2}$ " " " " 7 " " " "	"	10.45

COMBINATION SHAKERS

No. 2—Shaker and Strainer Combined, Nickel-Plated	per doz.	32.40
---	----------	-------

LIQUOR JIGGERS

No. 1—Liquor Jiggers, Nickel-Plated	per doz.	9.35
" 2— " " " " Combination, Pony and Regular Size	"	10.80

ICE SCOOPS



No. 1—Ice Scoop, Heavy, Nickel-Plated	per doz.	18.00
" 2— " " " " with Wood Handle	"	15.85

No. 1

No. 2—R
" 3—C

BAR SUPPLIES

STRAINERS

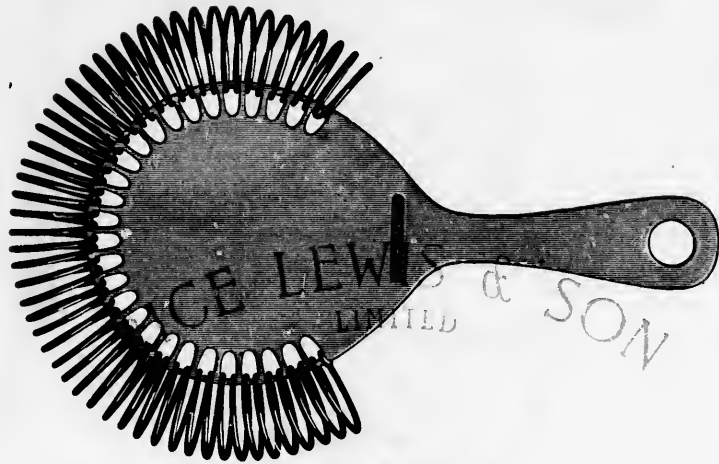

No. 1—Julep Strainer, Nickel, Silver-Plated..... per doz. \$10.80



RIBBED



CLIMAX

No. 2—Ribbed Strainer, Nickel-Plated..... per doz. 5.75
 " 3—Climax " " " " 10.80

ze cut.

\$8.65
 2.00
 2.00
 12.25
 14.40
 19.45

32.40

9.35
 10.80

18.00
 15.86

BAR SUPPLIES



MUDDLER



WHIRLING SPOON

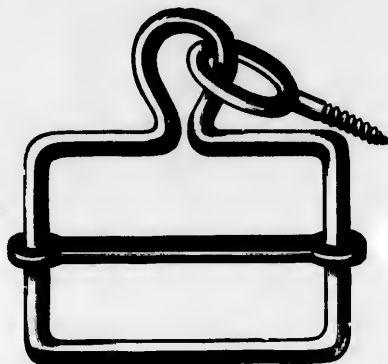

HAUCK'S TOWEL HOLDER



RIBBED TOWEL HOLDER

No. 81—Whirling Spoon, Nickel-Plated.....	per doz.	\$28.80
“ 82.. Bar Spoons, “ “ Round Handle, Length 5 inches.....	“	2.90
“ 83— “ “ “ “ “ “ “ “ “ “ “ “ 7½ “	“	3.60
“ 84—Muddlers, Nickel-Plated, Length 6 inches, as per cut.....	“	5.75
“ 85— “ Wood, “ “ “ “ “ “ “ “ “ “ “ “ 6 “	“	1.45
“ 86—Hauck's Patent Towel Holders, Nickel-Plated	“	3.00
“ 87—Ribbed Towel Holders, “ “	“	2.15



No. 70



No. 75



No. 80

No. 70—Mounted Cork, with Chain and Spring, Nickel-Plated.....	per doz.	2.20
“ 75—Bottle Caps, Nickel-Plated.....	“	1.50
“ 80—Bitter Tubes, Silvered, with Detachable Cork.....	“	2.20

BOTTLE STOPPERS



No. 4293



No. 5



No. 4288



No. 409

No. 4293—Nickel-Plated Metal Body, Loose Key, Rubber Centre	per doz.	\$7.05
" 5—Boxwood Body, Brass Detachable Key, Rubber Centre	"	5.15
" 1—Plain Wood Body, Wing Nut, Rubber Centre	"	0.85
" 3A—Boxwood, Burnished Ornamental Nut, Rubber Centre	"	3.00
" 4288—Nickel-Plated Metal Body, Rubber Centre	"	5.75
" 409—White Metal, Cork Lined	"	3.00
" 409C— " " Nickel-Plated	"	3.75

LDER

\$28.80
2.00
3.00
5.75
1.45
3.00
2.15

CHAMPAGNE TAPS

Half size cuts.



No. 50



No. 55

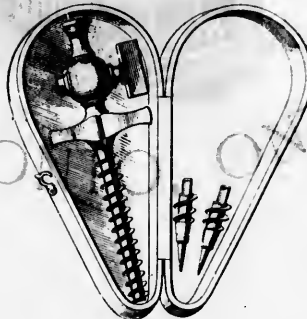

No. 60



No. 65

No. 50—Abyssinian Pattern, Nickel-Plated	per doz.	6.50
" 55—With Cut Spiral Worm, "	"	8.40
" 60—Milne's Patent, in Silk-Lined Leather Case, Nickel-Plated	"	15.50
" 65—Ebonite Wood Handle, Cut Worm, Nickel-Plated	"	10.30

2.20
1.50
2.20

WOOD FAUCETS

BOKER'S



Nos. 323 and 323 1/2

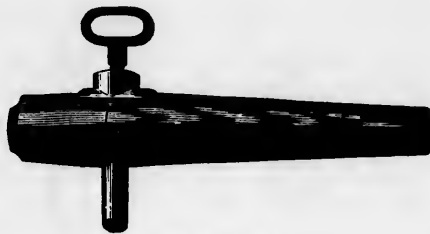

Nos. 325 and 325 1/2

Nos.....			2-0	1-0	1	2	3	4	5	6
No. 323 —Fast Key, Tinned, Polished Cherry.....	per doz.	\$0.95	1.05	1.15	1.30	1.60	2.00	2.35	2.55	
" 323 1/2 — " " Stained and Polished Apple.....	"	0.85	0.95	1.00	1.15	1.35	1.70	1.90	2.40	
" 325 —Loose Key " Polished Cherry.....	"	1.15	1.30	1.45	1.60	1.85	2.20	2.70	3.00	
" 325 1/2 — " " Stained and Polished Apple.....	"	1.05	1.15	1.25	1.35	1.55	1.85	2.15	2.65	

Half-dozen in a package.

SOMMER'S WOOD FAUCETS



Maple, Polished, Leather Lining, Block Tin Key.

No.....			2	3
Length.....			12	14 inch.
Peerless Beer Faucets, with Tinned Rings.....	per doz.	\$7.20		8.40



Maple, Polished, Leather Lining, Block Tin Key.

No.....	0 1/2	1	2
Length.....	8	9	12 inch.
Peerless..... per doz.	\$4.80	5.40	6.00

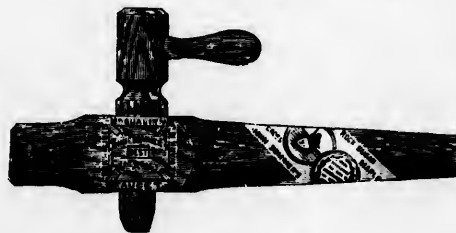

Maple, Cork Lined.

No.....			4	6	8
Length.....			8	9	10 inch.
IXL, Boiled in Linseed Oil, per doz.		\$1.20	1.50	1.80	

REDLICH'S PATENT CORK LINED

No.....			2	4
Length.....			8	10 inch.
Boiled in Gutta Percha.....	per doz.	\$1.50		1.90

ORDINARY CORK LINED WOOD FAUCETS

No.....			4	6	8
Length.....			8	9	10 inch.
Per dozen.....		\$1.00	1.25	1.50	
Beer Vents, Apple Wood, Length 7 inches.....	per doz.				\$1.65

WHITE METAL WINE FAUCETS



No. 348



No. 347

Size Nos	1	2	3	4	5	6
Length over all	3 $\frac{1}{2}$	4	4 $\frac{1}{2}$	5	5 $\frac{1}{2}$	6 inch.
No. 348—Screw Key	\$1.40	1.55	2.10	2.60	3.30	3.70
" 347—Screw Key, for soldering to small basins or barrels, "	2.25

BRASS RACKING COCKS

Best Yellow Metal.

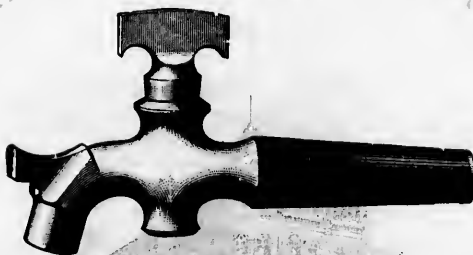

Out of Fast Key, to Drive.

FAST KEY, TO DRIVE

LOOSE KEY, TO DRIVE

Size	5/16	3/8	7/16	1/2	5/8	3/4 inch.	Nos.....	403	405	409	413	415
Per dozen	\$4.15	4.50	5.25	6.80	9.00	12.40	Size	1/2	5/8	3/4	7/8	1 inch.
							Per dozen	\$4.75	5.40	7.00	8.10	9.40

BOTTLING COCKS



Nos.....	947	948
Size	1/2	3/4 inch.
Silver-Plated In and Outside	\$15.15	18.75
per doz.		

BEER COCKS

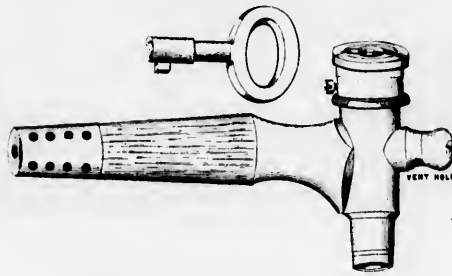

Best Yellow Metal, with Vent.

No. 1704-- $\frac{3}{4}$ inch, to Drive, with Patent Vent..... per doz. \$15.00

Half dozen in a package.

PETROLEUM FAUCETS

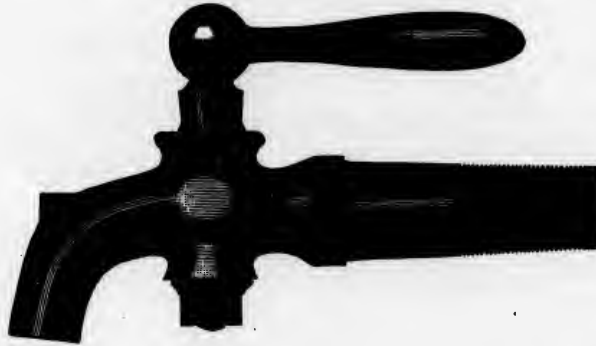

Size	$\frac{1}{2}$	$\frac{5}{8}$	$\frac{3}{4}$	1 inch.
With Screw Shank	per doz. \$8.25	9.00	10.50	12.00

Half dozen in a box.

PERFECTION FAUCETS



Inside Diameter	$\frac{1}{2}$	$\frac{3}{4}$	1	$1\frac{1}{4}$	$1\frac{1}{2}$	2	3 inch.
With Screw Shank	per doz. \$9.50	12.00	14.00	16.50	20.00	28.00	36.00

Half dozen in a box.

MOLASSES AND OIL GATES

STEBBINS'



Nos	1	2	3	4
Inside Diameter	1 1/2	1 3/4	1 7/8	2 inch.
Per dozen	\$7.00	8.00	9.00	10.00

Half dozen in a box.

MEASURING FAUCETS AND PUMPS

ENTERPRISE



No. 65



No. 197

No. 65—Improved Patent Suction and Force Measuring Faucet, Tinned, for molasses, thick oils, tar, etc., Imperial Measure each \$4.25

No. 197—Self-Priming and Measuring Pump, Tinned, for measuring molasses, heavy oils, tar and other thick liquids. Has a patent Clamp, operated by Thumbcrew, to fasten to barrel; extreme length 54 inches; each revolution of the Crank pumps a gill, 4 revolutions a pint, etc., Imperial Measure each \$7.50

Special 3 inch Auger, as shown, extra each 1.15

CORK SCREWS

FOLDING POCKET CORK SCREWS



No. 621



No. 6668



No. 671



No. 7282

No. 621-6	Width 3	inches, Round Worm, Polished	per doz.	\$1.25
" 6668N	" 2½	" " " Nickel-Plated	"	3.00
" 488N-6	" 3	" " " " " " " " " "	"	1.00
" 671-5	" 2½	" " " Polished	"	0.70
" 7157	" 2½	" " " Heavy	"	2.25
" 7282-5	" 2½	" " " Left Hand, Nickel-Plated	"	1.65



No. 2398



No. 1368



No. 5364



No. 09NP



No. 5312

No. 2398	Width 3½	inches, Twisted Fluted Worm, Hard Polished	per doz.	6.05
" 2403	" 2	" " " " " " " " " "	"	4.15
" 1368	" 1½	" " " " " " " " " "	"	4.70
" 2368	" 1½	" " " " " " " " " "	"	3.05
" 5364	" 3	" " " Cyphered Worm, Hard Polished	"	6.35
" 09NP	Length 4	" " " Sharp " Brass Case, 1½ inch Heavy Split Ring	"	4.25
" 5312	" 2½	" " " Peg and Fluted Worm, Hard Polished	"	3.95



No. 7171



CLOSED



BARREL SHAPE

No. 7171	Pocket Lever, Length 4	inches, Sharp Worm, Nickel-Plated	per doz.	5.45
" 6038	Barrel Shape, " 3	" " Metal Case, Nickel-Plated	"	2.40
" 583N	" " " 3	" " Round " Brass " " " "	"	6.00
" 9373	" " " 2½	" " Twisted Fluted Worm, Brass Case, Nickel-Plated	"	7.80
" 1374	" " " 3½	" " " " " " " " " " " "	"	9.65

CORK SCREWS



No. 7296



No. 7093



No. 7310



No. 6145



No. 6151

No. 7296—Wood Handle, Length 5 inches, Sharp Worm.....	per doz.	\$1.05
" 7093— " " " 5½ " " "	"	2.05
" 7310—Buff " " 4½ " Round "	"	2.85
" 6145—Wood " " 6 " Sharp "	"	2.75
" 6151— " " " 5 " " " Nickel-Plated, with Plated Ferrules.....	"	3.15
" 6154—As No. 6151 " 5½ " " " " " " "	"	4.20

SOLID HANDLE CORK SCREWS



No. 6364



No. 1886



No. 7110



No. 527½



No. 0195

No. 520—Iron, Solid, Width 2½ inches, Sharp Worm, Bright.....	per doz.	0.35
" 6364—Iron Head, " 3 " Round " Nickel-Plated.....	"	2.65
" 1886— " " " 3 " Sharp " Bright Finish	"	1.25
" 7110— " " " 3 " Round " Coppered	"	2.80
" 527½— " " " 2½ " Sharp " Bronzed	"	1.00
" 0195— " " " 3 " Round " "	"	2.45
" 7020— " " " 3½ " " " Polished, Style as No. 0195	"	1.15

CORK SCREWS

ENGLISH MAKE

Half size cuts.



No. C943



No. 2193



No. 2129

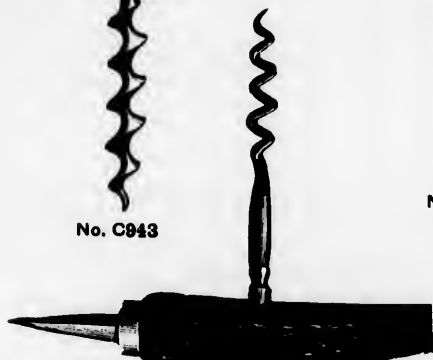

No. 6122

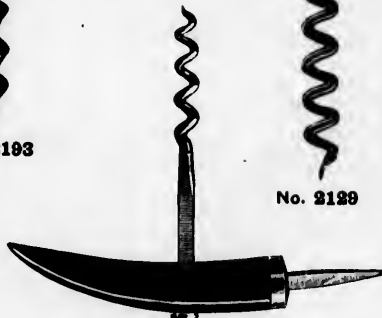

No. 2121



No. 7135



No. L015



No. 9369

No. C943—Stag Horn Handle, Sharp Worm, Nickel-Plated.....	per doz.	\$9.35
" 2193—Black Wood " " Fluted " "	"	4.70
" 2129—Stag Horn " " Round " "	"	8.40
" 6122—Pressed " " Round " Polished	"	3.55
" 2121—Buff " " " " "	"	3.35
" 7135—Stag " " " " "	"	2.25
" L015—Malleable Iron " " Sharp " "	"	2.00
" 9369—Bone " " Round " Hard Polished	"	0.75

SELF-PULLING CORK SCREWS



No. 1397



No. 5479



No. 34

No. 1397—Challenge, Bronzed, Round Worm.....	per doz.	\$10.30
" 5479—Surprise, " Sharp "	"	7.75
" 1719N—Nickel-Plated, Round Worm, Wood Head with Spiral Spring, Style as No. 5479	"	2.00
" 34— " Sharp "	"	5.40

LEVER CORK SCREWS



No. 6429

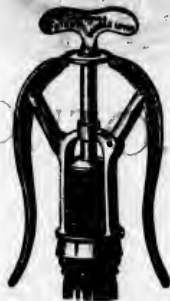

No. A1



No. 2424

No. 6429—New Patent Double Lever Cork Screw, Copper Bronzed	per doz.	11.00
" A1—Improved " " "	"	14.65
" 2424—Compound Lever Cork Screw, 4 Levers, Copper Bronzed	"	14.65
" 7430— " " 2 " " Style of No. 2424	"	9.75

LEVER CORK SCREWS



No. 202



No. L 515



No. 225

No. 202—Land's Genuine, Bronzed, complete, with Shank and Worm.....	per doz.	\$9.10
" 315— " Pattern, " " " " " " "	"	5.50
" L 515—Tangent " " " " " " "	"	8.00
" 225—Extra Bronzed Shank and Round Worms, for Lever Cork Screws	"	3.95

STATIONARY CORK PULLERS

Adapted for use in Hotels, Bar-Rooms, Clubs, Restaurants, etc.

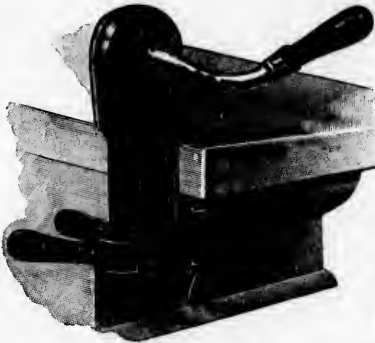

CHAMPION



No. 1236

Champion—Nickel-Plated, with Latest Improved Bottle Holding Clamp.....	each	\$5.50
No. 1236— " Powerful, Quick Worker.....	"	4.55

These Machines will quickly and safely draw the cork from any bottle, and as readily re-cork it.

One in a Wood Box, one half dozen in a Case.

SEAM

Nos. .
Inches
Straig
Ten C
Sauce

NOTE.

SE

Inches
Per do

Nos. .
Diam
Re-tn

Nos. .
Inche
Seam

DIAMOND ENAMELLED WARE

TEA CUPS AND SAUCERS



SEAMLESS STRAIGHT MUGS IMPROVED PATTERN SAUCERS IMPROVED PATTERN TEA CUPS

Nos.	7	8	9	10	11	13	14	15
Inches.	3½ x 3	3½ x 3½	3½ x 3½	4½ x 3½	4½ x 4	5½ x 4½	5½	5½
Straight Mugs	per doz.	\$1.75	2.00	2.35	2.75	3.25	4.00
Tea Cups	"	1.00	2.00	2.25
Saucers	"	1.30	1.50

NOTE.—The Improved Pattern Tea Cups are same diameter, but one inch less in depth, than the Straight Mugs.

SEAMLESS BOWLS

SOUP PLATES

DINNER OR PIE PLATES



Inches..	6	7	8	10	12	Inches..	7	8	9	10	Inches..	7	8	9	10
Per doz.	\$2.25	3.00	3.50	7.00	11.00	Per doz.	\$1.00	1.80	2.00	2.50	Per doz.	\$1.00	1.80	2.00	2.50

FRYING PANS



Nos.	7	8	9	
Diameter of Bottom	8½	10½	12½ inch.	
Re-tinned Handles	per doz.	\$6.75	7.50	8.00

OBLONG ROAST PANS

JELLY CAKE PANS



Nos.	6	7	8	9	Inches	9	10
Inches	8 x 14	10 x 15	11 x 16	12 x 17	Per doz.	\$2.75	3.25
Seamless. per doz.	\$8.00	9.50	10.50	12.50			

DIAMOND ENAMELLED WARE

TEA POTS



With Re-tinned Covers.

Nos.....	0	10	20	30	40	50
Quarts	1	1½	2	3	4	5
Per dozen	\$8.00	9.00	10.00	11.50	13.00	15.00

COFFEE POTS



With Re-tinned Covers.

Nos.....	15	25	35	45	55
Quarts	1½	2	3	4	5
Per dozen	\$9.00	10.00	11.50	13.00	15.00

TEA KETTLES



Pit Bottom.

Nos.....	7	8	9
Quarts	5	7	8
Per dozen	\$18.00	20.00	24.00



Flat Bottom.

Nos.....	50	60	70	80	90
Inches	6	7½	8½	9½	10½
Per dozen	\$14.00	18.00	18.00	20.00	24.00

TEA STEEPERS



Seamless, with Re-tinned Covers.

Nos.....	1	2
Inches	4½ x 3¾	4½ x 4
Per dozen	\$5.00	6.00

RICE OR MILK BOILERS



Seamless.

Nos.....	52	53	54	56
Pints (inside Boiler).....	2	4	6	8
Per dozen.....	\$13.50	17.50	22.00	27.00

DIAMOND ENAMELLED WARE

LIPPED PRESERVING KETTLES



Nos.....	20	22	24	26	28	30	32	36	40
Quarts.....	3	4	5	6	8	10	12	14	18
Inches.....	8½	9½	10	10½	11½	12	13	13½	14½
Per dozen.....	\$6.00	7.00	8.00	9.00	10.50	12.50	15.00	18.00	22.50

45 55
4 5
3.00 15.00

DEEP PUDDING PANS



OBLONG PUDDING DISHES



Quarts.....	1	1½	2	3	4	6	Nos.....	10	11	12	13
Inches.....	6½x2½	7½x2½	8½x2½	9½x3½	10x3½	11½x3½	Inches.....	10½	11	12	13
Per dozen....	\$3.00	3.50	4.00	4.50	5.00	6.50	Per dozen.....	\$4.00	4.50	5.50	6.50

30 90
9½ 10½
0.00 24.00

MILK PANS



Quarts.....	½	1	1½	2	3	4	6	8	10	12
Inches.....	6½ x 1½	7 x 1½	7½ x 1½	8½ x 2	9½ x 2½	10½ x 2½	12½ x 3	13½ x 3	14 x 3½	15½ x 3½
Per dozen.....	\$2.00	2.50	3.00	3.50	4.00	5.00	6.00	6.50	7.00	8.50

BASTING SPOONS



Inches.....	12	14	16	
Heavy, Threaded Handles.....	per doz.	\$1.75	1.90	2.00

56
8
00 27.00

DIAMOND ENAMELLED WARE

LIPPED SAUCE PANS



WINDSOR SAUCE PANS



LIPPED SAUCE PANS

Nos.....	10	12	14	16	18	20	22	24	26
Quarts.....	3	1	1½	2	2½	3	4	5	6
Inches.....	5½	5¾	6¾	7¾	7¾	8½	9½	10	10¾
Per dozen.....	\$2.50	3.00	3.50	4.00	5.00	6.00	7.00	8.00	9.00

WINDSOR SAUCE PANS

Nos.....	12	14	16	18	20	22	24	26
Quarts.....	1	1½	2	2½	3	4	5	6
Inches.....	5¾	6¾	7¾	7¾	8½	9½	10	10¾
With Re-tinned Covers..... per doz.	\$4.50	5.25	6.00	7.00	8.00	9.25	10.50	12.00

STRAIGHT SAUCE PANS



Seamless, with Re-tinned Covers.

SEAMLESS KETTLES



Seamless, with Re-tinned Covers.

STRAIGHT SAUCE PANS

Nos.....	200	300	400	600	800	1000
Inches.....	5½x4½	6½x4¾	7¾x5	8½x5½	9½x6	10½x6½
With Re-tinned Covers..... per doz.	\$5.00	6.00	7.50	9.00	11.00	13.00

SEAMLESS PAILS OR KETTLES

Quarts.....	1	2	3	4	6	8	10
Inches.....	4¾x4	5½x4½	6½x4¾	7¾x5	8½x5½	9½x6	10½x6½
With Re-tinned Covers..... per doz.	\$4.50	5.00	6.00	7.50	9.00	11.00	13.00

No.
Inch
Per

No.
Quan
Piece
Seam

Size
Funn
Fam
Size
Impe

TINWARE

DISH PANS



Stamped, Flat Edges.

		PLAIN				
Quarts.....		8	10	14	17	21
Inches.....		13½ x 4½	15 x 5	10½ x 5½	18 x 5¾	19½ x 6¾
IC....per doz.		\$5.75	7.00	8.25	9.75
		RE-TINNED				
IC....per doz.		\$8.35	9.25	10.75	12.50
IX.... "		9.25	10.25	12.25	14.75	17.50

KNEADING PANS



Stamped.

		RE-TINNED	
Quarts.....		17	21
Inches.....		17½ x 6¾	19½ x 7¾
IC, with Covers.....	per doz.	\$31.25
IX, ".....		39.00	50.00
Covers only, Plain.....		7.75	10.00
" Re-tinned.....		11.25	13.35

MILK PANS

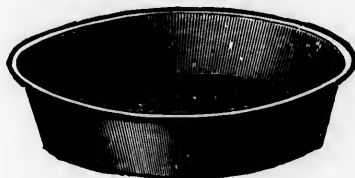

Stamped.

Quarts.....		¼	½	1	1½	2	3	4	6	8	10	12	
Inches.....		4½ x 1½	6½ x 1½	7 x 1½	7½ x 1½	8½ x 2	9½ x 2½	10½ x 2½	12½ x 3	13½ x 3	14 x 3½	16 x 3½	
IC, Plain.....	per doz.	\$0.95	1.05	1.25	1.55	1.75	2.05	2.65	3.35	4.00	4.45	5.25	
IC, Re-tinned.....		"	1.40	1.65	2.00	2.40	2.65	3.05	4.00	5.00	6.00	6.65	7.75

CULLENDERS



Stamped.

No.		306
Inches.....		11½
Re-tinned.....	per doz.	\$7.75

MILK STRAINERS

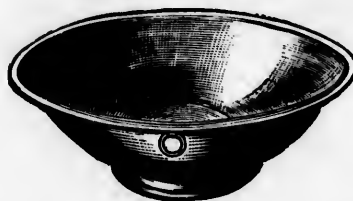

Stamped.

Nos.....		21	22	23
Inches.....		8	10½	11½
Plain.....	per doz.	\$3.35
Re-tinned.....		4.50	6.05	7.75

TINWARE

DAIRY PAILS



Stamped, Extra Heavy.

MILK STRAINER PAILS



Pieced.

LEWIS & CO. LIMITED

Nos.....	12	14	16	Quarts.....	10	14		
IX, Plain.....	per doz.	\$10.50	12.50	14.50	I.C.....	per doz.	\$3.60	4.20
IXX, Re-tinned, Malleable Ears	"	16.50	19.00	21.75	With Feet, Extra.....	"	0.30	0.37

COVERED PAILS



Pieced.

STEAMERS



Pieced.

ROUND DINNER PAILS



Pieced.

Quarts.....	1	2	3	4	6	8	12	16	
Covered Pails.....	Per gross	\$10.80	12.00	14.40	19.80	25.20	33.30	41.40	51.30
Nos.....					7	8	9	10	
Steamers.....	per doz.	\$2.47	2.62	2.77	4.12				
Quarts.....						3	4		
Round Dinner Pails, with Cup and Tray.....	per doz.	\$2.10	2.70						

21
19 1/2 x 7 1/2
.....
50.00
10.40
13.35

12
16 x 3 1/2
5.25
7.75

23
11 1/2
.....
7.75

TINWARE

PUDDING PANS



Stamped, Extra Deep.

Quarts.....	1	1½	2	3	4	6	8	10
Inches.....	6½ x 2¾	7¾ x 2¾	8¾ x 2¾	9½ x 3¼	10½ x 3¼	12 x 3¼	14 x 3¼	16 x 3¼
Plain.....per doz.	\$1.65	1.95	2.25	2.65	3.10	4.15	5.25	6.00
Re-tinned....."	2.50	2.75	3.35	4.00	4.50	6.00	7.35	8.65

WASH BOWLS



Stamped, Flat Bottom.

Inches.....	10½	11½	12½	13½	14½
IC, Plain...per doz.	\$2.55	2.90	3.30	3.75	5.00
IC, Re-tinned "	3.00	4.10	4.65	5.35	7.55
IX, Plain.... "	3.00	3.25	4.00	5.00	6.75
IX, Re-tinned "	4.50	5.00	5.50	6.75	9.50

DIPPERS



Stamped, Extra Heavy.

Inches.....	6¼ x 4
Quarts.....	1
Re-tinned.....per doz.	\$6.65

TEA KETTLES



Pieced.

Nos.....	6	7	8	9	10
Flat Tin Bottoms, IC...per doz.	\$2.70	3.00	3.00
Pit Copper Bottoms, IC "	4.50	4.87	5.25	5.85	6.90
Pit Copper Bottoms, IX "	5.62	6.00	6.75	7.87

OVAL WASH BOILERS



Pieced.

Nos.....	7	8	9	10
Flat Tin Bottom, IC.....each	\$0.67	0.75
" " IX....."	0.82	0.90
Flat or Pit Copper Bottom, IC "	\$1.05	1.05	1.20	1.85
" " " IX "	1.20	1.20	1.35	1.87

TINWARE

PIE PLATES



Stamped.

Inches.....	6	7	8	9	10	11
Per gross.....	\$9.75	11.75	13.75	15.75	21.25	26.50

JELLY CAKE PLATES



Stamped.

Inches.....	8	9	10	
Plain, Deep.....	per gross	\$19.50	21.75	27.75
Re-tinned, Deep.....	"	28.75	32.25	41.25

CAKE PANS



Stamped.

Inches.....	6	8	10	
Scalloped, Tubed.....	per doz.	\$1.65	1.00	2.35

JELLY MOULDS



Stamped.

Nos.....	10	15	20	
Quarts.....	1	1½	2	
Re-tinned.....	per doz.	\$8.35	9.75	11.10



Stamped, Rimmed, Re-tinned Copper Tops.

Pints.....	1	1½	2	LION
Per dozen.....	\$13.05	15.25	19.70	19.70

FRENCH DARIEL OR JELLY CUPS



Assorted Patterns, Re-tinned.....	per doz.	\$3.35
-----------------------------------	----------	--------

10
10 x 3½
0.00
8.05

6¼ x 4
1
\$6.65

10
75
90
10 1.65
5 1.87

TINWARE

MUFFIN PANS



Stamped, on Frame.

Nos.	6	8	12
Cups on Frame	6	8	12
Per doz.	\$5.00	6.40	9.35

TURK'S HEAD PANS



Stamped, on Frame.

Nos.	106	108	112
Cups on Frame	6	8	12
Per doz.	\$5.75	7.25	10.50

BREAD PANS



Stamped.

Nos.	1	2	3, BOSTON	110	210
Inches	10½ x 6½ x 2	9½ x 5½ x 2½	10½ x 6½ x 3¾	8½ x 4½ x 3½	14½ x 4½ x 3¾
Tin	per doz.	\$0.82	0.75	0.97	0.90
Iron	"	0.82	0.75	0.97

SHEET IRON AND STEEL WARE



A 1 IRON DRIPPING PANS

Nos.	6	7	8	8½	9
Inches	12 x 9	14 x 10½	16 x 11½	18 x 10	17 x 12½
Per doz	\$1.05	1.50	1.90	1.95	2.02

SHEET IRON OVEN PANS

Sheets	½	¾	1
Inches	9 x 15	10½ x 15½	14 x 19½
Per doz.	\$1.12	1.50	2.02

STEEL FRY PANS



Handle and Body One Piece.

ACME						HEAVY			
Nos.	1	2	3	4	5	6	7	8	9
Diameter	7	7½	7½	8	8½	9½	8½	9½	10½
Per doz.	\$1.87	2.10	2.52	2.62	3.00	3.37	\$3.15	3.67	4.35

TINWARE

IMPERIAL MEASURES



Size	1/2 pt.	1 pt.	1 qt.	1/2 gal.	1 gal.
Polished Ware, Inspected.....	per doz.	\$2.25	2.85	3.37	4.90
Per Set of Five.....				per set	1.60

OIL CANS



	Flaring Top.					
Gallons	1/2	1	2	3	5	Gallons
Per dozen	\$1.87	2.25	3.52	4.50	5.62	The Slick
						per doz.
						\$18.00

DUSTPANS



1C, Plain.....	per doz.	\$3.00
1C, Japanned	"	3.60
1X, "	"	5.00

CUSPIDORS



Assorted Colors, Gold Bands.	
No.....	10
Daisy	per doz. \$1.06

112
12
10.50

210
x 4 1/2 x 3 3/4
1.12
....

1
14 x 19 1/2
2.02

9
10 1/2
4.35

GALVANIZED STEEL BUCKETS



IMPROVED PATTERN

Nos.....	12	14	16
Quarts (Wine Measure).....	10	13	16½
Per dozen.....	\$2.85	3.15	3.52

Riveted Seams supplied at 45 cents per doz. extra.

MAPLE LEAF SAP SPOUTS

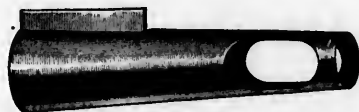

Tinned Steel.....per 1000 \$6.75 | Length 2½ inches.....per 1000 \$7.50

GALVANIZED COAL HODS



STANDARD, OPEN

Inches.....	16	17	18
Per dozen.....	\$3.75	4.35	4.57

STANDARD, FUNNEL

Inches.....	17	18
Per dozen.....	\$5.40	5.77

SAP PAILS



EXTRA DEEP AND STRAIGHT, WITHOUT COVERS

Nos.....	8	12	16
Inches.....	7½x13	8½x13	10½x13
Tin, Pieced.....per 100	\$7.50	9.97	12.00

FLARING, WITHOUT COVERS

Quarts.....	6	10
Tin, Pieced.....per 100	\$7.50	9.97

COVERS, DETACHABLE

Nos.....	8	12
Tin.....per 100	\$2.62	3.37

DOMINION SAP SPOUTS



JAPANNED COAL HODS



STANDARD, OPEN

Inches.....	16	17	18
Plain.....per doz.	\$3.00	3.60	3.82

STANDARD, FUNNEL

Inches.....	17	18
Gold Band.....per doz.	\$4.50	4.87

CAMP COOK STOVES

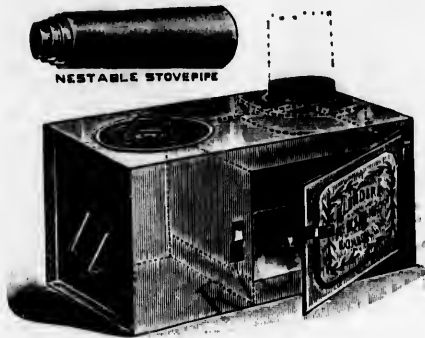

No. 1



No. 2

STOVE SET UP AND FOLDED FOR SHIPPING

Size of Stove.	Size of Oven.	Pot Holes.	Weight.		
No. 1—24 x 12 x 12 inches	11½ x 12 x 8½ inches	One 8½ inches	16½ lbseach	\$2.30
" 2—25 x 16 x 14 "	16 x 12 x 8½ "	Two 8½ "	43 ""	6.30
" 4—27 x 21½ x 14½ "	21½ x 13½ x 8½ "	Four 8½ "	63 ""	8.10

No. 2 folds into 25½ x 17 x 3 inches, No. 4 into 27 x 21½ x 8½ inches. No. 1 supplied with 4 lengths of Telescope Pipe, which will extend 3½ feet; Nos. 2 and 3, 5 lengths, which will extend 9½ feet; also Damper for Pipe and Thimble for Tent.

ALUMINUM CAMPING OUTFITS



No. 1—Set for 3 persons.....	each	\$ 9.90
" 2— " 6 " Weight 3½ lbs.....	"	11.70

Each Set consists of one 8 quart Pail, 10½ inches diam. x 6½ inches deep; one 6 quart Pail, 9 inches diam. x 5½ inches deep; one 4 quart Pail, 8 inches diam. x 5 inches deep; three or six Cups, 3½ inches diam. x 3 inches deep; three or six Plates, 9 inches diam. Each Set packs inside large Pail. Covers for all the Pails are suitable for Fry Pans, etc., and are supplied with Folding Handles.

18
3.82

18
4.87

ADJUSTABLE STOVE PIPES



STANDARD

Diameter.....	5	6	7 inch.
Per 100 lengths.....	\$8.33	8.33	9.00

TRIUMPH

Diameter.....	5	6	7 inch.
Per 100 lengths.....	\$8.05	8.05	8.05

Nestled, 25 Joints in a crate.

ONE-PIECE ELBOWS

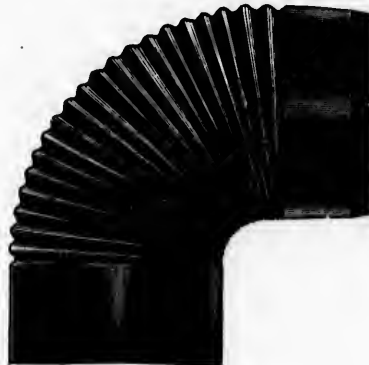

No. 2, STANDARD

Diameter.....	6	7 inch.
Plain.....per doz.	\$1.15	1.15
Polished....."	1.35	1.35

No. 1, EXTRA HEAVY

Diameter.....	5	6	7 inch.
Plain.....per doz.	\$1.15	1.50	1.50
Polished....."	1.35	1.70	1.70

GEM STOVE PIPE COLLARS

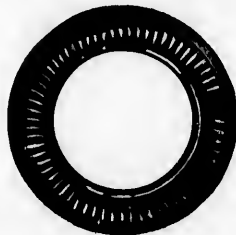

GEM FLUE STOPPERS



Inches.....	5	6	7
Per gross.....	\$4.50	5.25	6.00

Inches.....	8 ¹ / ₂
Per gross.....	\$7.50

STOVE PIPE DAMPERS



Size.....
Uncle Sam..... per doz. $5\frac{1}{2}$ 6 7 inch.
 \$1.20 1.30 1.58

The Plate is stamped out of Cold Rolled Steel, Malleable Iron Stem, Enamelled Wood Handle rigidly clamped to the Stem.

STOVE BOARDS



Embossed, White Brilliant, Wood Lined.

Size.....	30	32	34	36 inch.
Square..... per doz.	\$30.00	31.25	32.75	34.00
Size.....	26 x 34	28 x 36	30 x 40	inch.
Oblong..... per doz.	\$31.00	32.00	36.00	

STAR THIMBLES

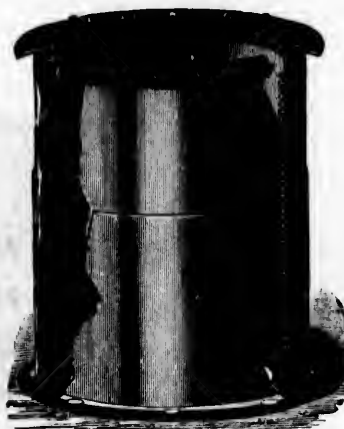

Cast Iron Ends.

Nos.....	3	4	5	6
Size.....	6	6	7	7
Extension.....	4 to 8	7 to 14	4 to 8	7 to 14
Per doz.....	\$12.00	13.50	12.00	13.50

DIAMOND EXTENSION STOVE BACK

Patented, July 11th, 1893.



CLOSED

Patented, July 11th, 1893.

Canadian Patent, June 14th, 1894.



EXTENDED.

Diamond Extension Stove Backs..... per doz. \$8.00

Can be adjusted to fit any width from 4 1/2 to 7 inches, and any length from 15 to 20 inches. All the extending parts are held in a secure position without the use of bolts, wedges or keys.

Half dozen in a box.

7 inch.
8.05

7 inch.
1.50
1.70

8 1/2
\$7.50

COFFEE AND TEA POTS

POLISHED TIN

COFFEE POTS



OCTAGON TEA POTS



Quarts.....	1	1½	2	3	4
Polished.....per doz.	\$1.50	1.65	1.80	1.95	2.25

Bowl Bottoms, Plain Spouts.

Nos.....	20	30	40	50	60
Pints.....	2	3	4	5	6
Per doz.....	\$1.95	2.10	2.25	2.40	2.62

STOVE SHOVELS

JAPANED



No 70

Nos.....	70	55	57
Length.....	15	16	23 inch.
Per gross.....	\$10.50	15.00	22.50
Stove Lifters, Malleable Iron, Bronzed.....			per gross \$ 5.50
" " Alaska, Nickel-Plated.....			" 22.80

STEEL SINKS

PAINTED

Inches.....	16 x 24	18 x 30	18 x 36
Each.....	\$1.20	1.35	1.57

GALVANIZED

Inches.....	16 x 24	18 x 30	18 x 36
Each.....	\$1.57	1.87	2.17



STOVE POLISH



Enameline, Stove Polish, Size No. 4.....	per gross	\$ 6.75
Blackene. " " in 5 lb. Tins.....	per tin	0.75

Enameline one-quarter gross in a box.

JAMES' DOME BLACK LEAD

James' Dome Black Lead.....	per gross	3.00
-----------------------------	-----------	------

Half-dozen domes in a box, 6 boxes in a packages.

RISING SUN STOVE POLISH

Rising Sun Stove Polish, Small Size.....	per gross	6.75
--	-----------	------

Two dozen in a package.

BUTLERS' DIAMOND STOVE PIPE VARNISH

In Patent Half-pint Packages.....	per doz.	1.30
-----------------------------------	----------	------

HARRIS' BLACKING AND HARNESS COMPOSITION



Ebonite Blacking, Waterproof, free from acid, requires no brushing.....	per doz.	4.20
Ebonite Harness Liquid, Waterproof, adapted for Harness, Leather Bags, Trunks, Etc.....	"	3.40
Harness Composition, Waterproof, gives a fine polish, with beneficial effects on Leather.....	"	3.20
Saddle Paste, Waterproof, for use on Saddles and Brown Harness, Boots, Etc.....	"	3.20

REGISTERS

TUTTLE & BAILEY PATTERNS

Vertical Wheel or Glide Movements, Japanned Black or White.

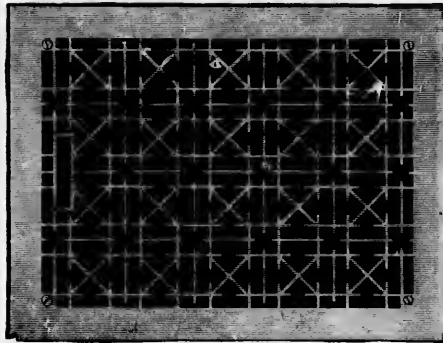

JAPANESE PATTERN



PERSIAN DESIGN

SQUARE REGISTERS AND VENTILATORS

SIZE OF OPENING.	Register.	Register Face.	Ventilator for Cords.	Floor Border.
6 x 8 inch.....each	\$1.90	\$0.65	\$2.15	\$1.15
8 x 10 "....."	2.50	0.85	2.75	1.40
8 x 12 "....."	2.80	1.00	3.05	1.50
9 x 12 "....."	3.30	1.25	3.55	1.55
9 x 14 "....."	3.60	1.50	3.85	1.65
10 x 12 "....."	3.60	1.50	3.85	1.80
10 x 14 "....."	4.25	1.85	4.50	1.90
10 x 16 "....."	4.75	2.15	5.00	2.00
12 x 15 "....."	6.00	2.40	6.25	2.40
12 x 17 "....."	6.75	2.80	7.00	2.60
12 x 19 "....."	7.50	3.20	7.75	2.80
14 x 18 "....."	8.75	3.50	9.25	3.15
14 x 22 "....."	10.00	3.90	10.50	3.70
16 x 24 "....."	13.00	6.00	13.50	4.35
20 x 24 "....."	18.00	8.25	18.50	6.00
20 x 26 "....."	20.00	8.75	20.50	6.75
27 x 27 "....."	29.00	14.25	29.50	8.50
30 x 30 "....."	38.00	17.65	38.50	10.00

Brilliant, Florentine, Plain or Indian Lattice Patterns can be supplied on short notice. If Ventilators are for Ceiling overhead, it should be so stated.

ROUND SLIDE-CENTRE FLOOR OR WALL REGISTERS

Japanned Black or White.

SIZE OF OPENING.	Register.	Register Face.	Ventilator for Cords.	Floor Border.
6 inch.....each	\$1.35	\$0.50	\$1.60	\$1.00
7 "....."	1.50	0.60	1.75	1.10
8 "....."	1.85	0.65	2.10	1.20
9 "....."	2.25	0.85	2.50	1.30
10 "....."	2.75	1.00	3.00	1.40
12 "....."	3.60	1.50	3.85	1.80
14 "....."	5.40	2.00	5.90	2.25
16 "....."	7.00	2.70	7.50	3.00
18 "....."	9.25	3.45	9.75	4.00
20 "....."	11.50	4.15	12.00	5.00
24 "....."	20.75	8.00	21.50	7.50
30 "....."	34.05	13.40	34.55	12.15

If Ventilators are for Ceiling overhead it should be so stated.

CASH BOXES

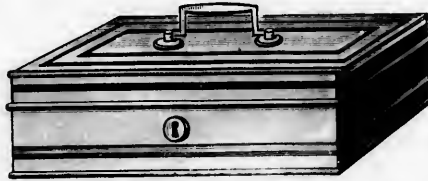

Japanned, Gilt Striped, Brass Handles.

Size	8	9	10	11	12	inch.
No. 4118 —With Tray, 2 Keys	each \$0.75	0.80	0.95	1.10	1.25	

Japanned, Gilt Striped, Heavy Brass Plate Handles.

Size	9	10	12	inch.
No. 037 —With Tray, Secure Lever Lock, 2 Keys	each \$2.50	2.80	3.10	

Japanned, Reinforced Corners, Gilt Striped, Brass Handles.

Size	9	10	11	12	inch.
No. 8127 —With Tray, 2 Levers, 2 Keys	each \$1.25	1.75	2.25	2.75	

Oak Finish, Brassed Bands, Heavy Brass Plate Handles.

Size	10	11	12	inch.
No. 137 —With Tray, 4 Secure Levers, 2 Keys	each \$5.50	6.40	7.00	

DEED BOXES



Japanned, Heavy Steel, Deed Boxes.

Size	12 x 8 x 7½	14 x 10 x 9½	16 x 11½ x 10	18 x 13 x 11	inch.
With 2 Flat Steel Keys	each \$2.50	2.75	3.00	3.25	

Japanned, Heavy Steel, Despatch Boxes.

Size	12 x 0½ x 4	14 x 8 x 5	inch.
With 2 Flat Steel Keys	each \$2.00	2.25	

BREAD OR CAKE BOXES



No.	1	2	3	inch.
Size	10½ x 0½ x 0½	17½ x 10½ x 10½	18½ x 11½ x 11½	
Japanned	each \$0.56	0.62	0.68	

SPEAKING TUBE AND ELBOWS

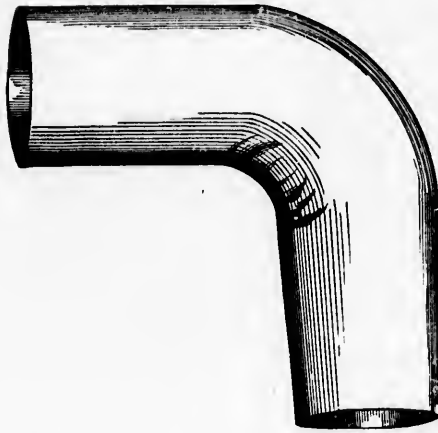

ROUND.

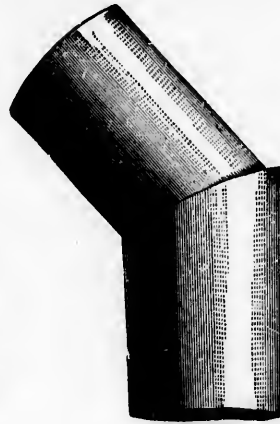

OBTUSE.

No. 859—Speaking Tube, Lock Seam, 1 inch Diameter	per 100 feet	\$2.70
" 860—Square Elbows for 1 inch Tube	per 100	3.30
" 861—Round	"	3.25
" 862—Obtuse	"	6.00
" 863—Speaking Tube Straps, Tin	"	2.25

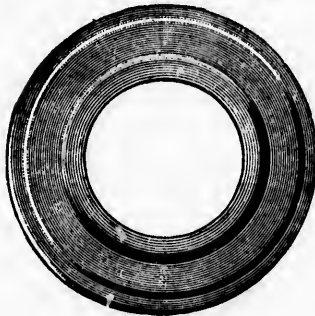

No. 30



No. 36

No. 30—Roses for Whistles and Mouth-Pieces, Nickel-Plated	per doz.	1.20
" 36—Open Mouth-Pieces, Nickel-Plated	"	2.25

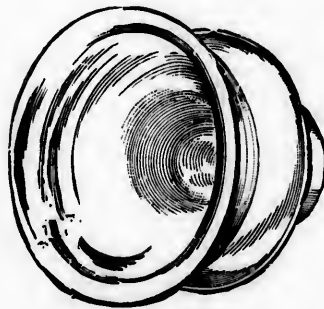

No. 33



No. 46½

No. 33 —Open Mouth-Pieces, Porcelain	per doz.	\$0.95
" 46½—Covered " Plain Bronze Metal, Swing Cover	"	7.20

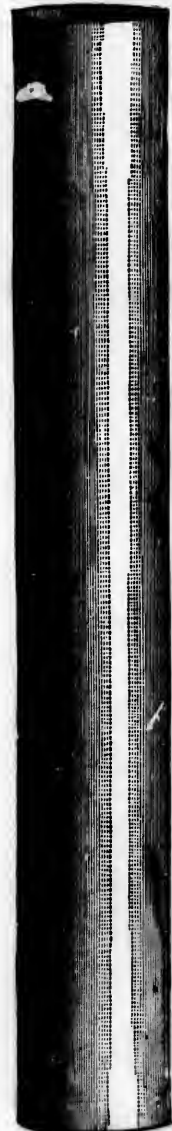

No. 859

SPEAKING TUBE WHISTLES



No. 158½

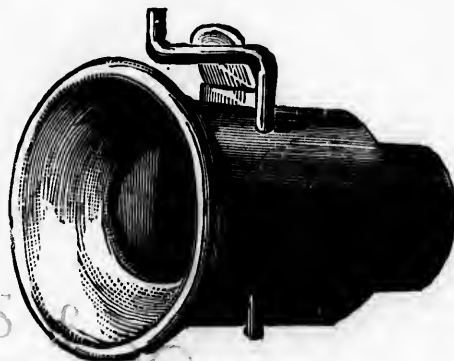

No. 1058

No. 158½	—Round Metal Whistle and Indicator, Nickel-Plated	per doz.	\$3.00
" 1058—	" " " " Porcelain Mouth-Piece, Japanned Body	"	2.50

ELBOW SPEAKING TUBE WHISTLE



No. 160

SLIDE SPEAKING TUBE WHISTLE



No. 190

No. 160	—With Indicator, Porcelain Mouth-Piece, Japanned Body	per doz.	\$ 7.50
" 190—	" " " " Nickel-Plated	"	20.25

FLEXIBLE SPEAKING TUBES



No. 78

- No. 78—Flexible Speaking Tube, covered with Black and Green Mohair, 1 inch diam.per foot \$0.55
- “ 93—24 inch Wall Flexible Tube with Nickel-Plated Metal Whistle and Collars..... each 3.00



No. 93

COLLARS

For Protecting Ends of Flexible Tube.

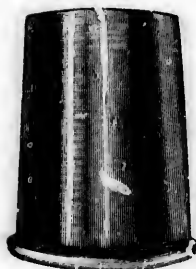

No. 79



No. 81

- No. 79—Nickel-Plated Collars for Ends.....per doz. \$3.00
- “ 81— “ “ Flange Collars..... “ 4.50

DISH COVERS

Bright Block Tin with N. P. Handles.



No. 100

Size..... 9 10 12 14 16 18 inch.
 No. 100.....each \$0.65 0.75 1.00 1.25 1.50 1.75



No. 101

Size..... 9 10 12 14 16 18 inch.
 No. 101.....each \$0.80 1.00 1.25 1.50 1.75 2.00

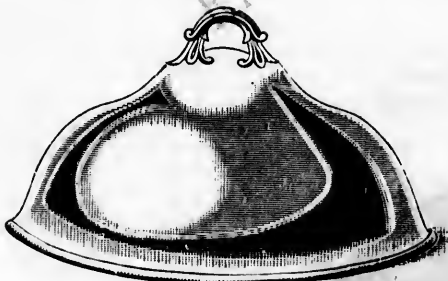

No. 102

Size..... 9 10 12 14 16 18 inch.
 No. 102.....each \$1.00 1.25 1.50 2.00 2.25 2.50



No. 103

Size..... 9 10 12 14 16 18 inch.
 No. 103.....each \$1.00 1.80 2.00 2.40 2.80 3.50

ROUND PLATE COVERS

Size.....	7	8	9 inch.
Each.....	\$0.50	0.65	0.75

HOT WATER BACON DISHES

With Block Tin Covers.

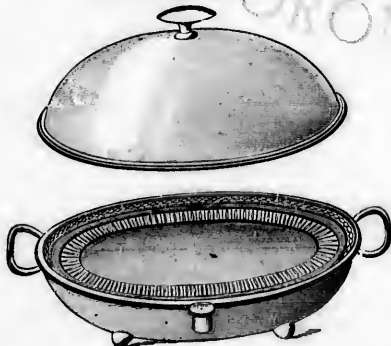

Size..... 10 12 14 inch.
 Each..... \$2.75 3.00 4.00

HOT WATER PLATES



Nos..... 200 201
 Each..... \$0.15 1.00

er doz. \$3.00
 " 4.50

BAKING DISHES

With Removable Porcelain-Lined Dish, for Serving Direct from the Oven.



Round, Nickel-Plated. With or Without Cover.

Nos.....	1	3	4	5
Size.....	1	3	3½	4 pints.
With Covers.....	each \$2.50	4.00	4.40	5.00
Without Covers.....	" 1.90	3.10	3.45	3.75

CHAFING DISHES

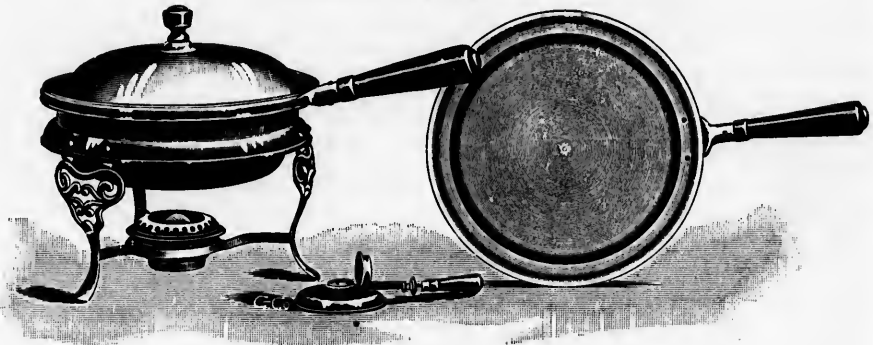

With Asbestos Force-Draught Lamps. Nickel-Plated Throughout.

Size.....	2	3 pints.
Each.....	\$5.00	6.30

SPIRIT POCKET STOVES



No. D546

Diam. at Base.....	3	3¼	3¾ inch.
No. D546—Napoleon.....per doz.	\$2.40	3.40	4.15

	Per doz.
New Pattern, Alcohol Cooking Stove, as D546, with Tin Kettle.	\$ 0.35
Philadome, " " " with Copper Kettle.....	25.00
La Favorite, with attachment suitable for Curling Tongs.....	2.25

PHILADOME

TABLE KETTLES

With Asbestos Force-Draught Lamps.



Nos. 2650 and 3650



No. 2560



No. 1930

No. 2650—	Polished Brass Kettle,	Wrought Iron Stand.....	each	\$2.85
" 3650—	" " " "	Brass Stand.....	"	4.70
" 2560—	" " " "	Wrought Iron Stand.....	"	6.75
" 1930—	" " " "	Brass Stand.....	"	7.15
" 1830—	" " "	Kettle only (similar to Kettle on No. 2500 Stand).....	"	4.45



No. 2480



No. 2460



No. 2620

No. 2480—	Polished Brass Kettle,	Wrought Iron Stand.....	each	7.25
" 2460—	" " " "	" " " ".....	"	8.15
" 2620—	" " " "	Brass Stand.....	"	4.70
" 1573—	" " "	Kettle only (similar to Kettle on No. 2620 Stand).....	"	3.15

5
4 pints.
5.00
3.75

3 pints.
6.30

3/4 inch.
.15

Per doz.
\$ 6.35
25.00
2.25

TABLE KETTLES

With Asbestos Force-Draught Lamps.



No. 1410



No. 2070



No. 2680

No. 1410	Polished Brass Kettle, Brass Stand.....	each	\$7.85
" 2070	" " Wrought Iron Stand.....	"	7.00
" 2070	" " Kettle only.....	"	3.00
" 2680	" " Wrought Iron Stand.....	"	6.70

TABLE KETTLES



No. 1450

VIENNA COFFEE MACHINES

Polished Brass, with Glass Cover.



No. 85

No. 1450	Polished Brass Kettle, Brass Stand.....	each	\$9.00
Size.....			
No. 85	Vienna Coffee Machines.....	each	\$5.60
" 285	" " all Brass.....	"	20.00
Extra Covers.....		"	0.30

JAPANNED STEEL TEA TRAYS



No. 7931

Size	12	16	18	20	24
No. 7911—Neat Gilt Border, Plain Centre..... per doz.	\$2.00	3.00	4.25	5.00	6.20
" 7931—" " " Fancy Gilt Centre, Hand Rubbed..	3.15	4.05	6.30	7.05	9.00
" 8934—Fancy Gilt Border, Plain Centre, Heavy Stock, Hand Rubbed.....	4.05	6.30	7.80	9.00	11.80
" 3930—Deep Fancy Gilt Border, Plain Centre, Heavy Stock, Double Hand Rubbed.....	5.40	7.20	9.00	10.80	13.80
" 0926—Heavy Gilt Border and Centre Piece, Extra Heavy Stock with Deep Fillet, Double Hand Rubbed.....	7.50	11.25	12.75	15.00	18.75

HAND-PAINTED STEEL TEA TRAYS



Art Designs, with Nickel Plated Handles.

Size	16	18	20	24
No. 4188—Chrysanthemum on Fancy Shaded Background..... each	\$2.70	3.10	3.25	4.15
" 1619—Daffodil on Oak Background..... "	2.85	3.15	3.45	5.05
" 9182—Rose on Fancy Shaded Background..... "	3.00	3.40	3.65	4.65
" 3189—White Clematis on Oak Background..... "	3.50	3.05	4.25

CARPATHIAN SILVER TRAYS

Wear white throughout.

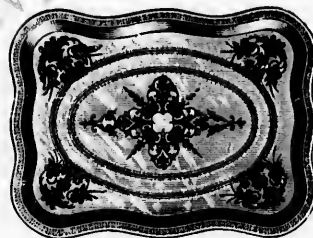

No. 7000

No. 10000

No. 12000

Size	6	8	10	12	14	16	18	20	22	24
No. 7000..... per doz.	\$7.50	11.25	14.65	34.50	49.50	71.25
" 10000..... "	\$5.25	6.00	7.00	12.00	15.75
" 12000..... "	\$5.40	6.00	7.15	8.65	13.50	18.00	28.50	41.25
Size.....	9	12
Marvel Waiters, White Metal, Polished, Assorted Designs..... per doz.	\$1.15	1.90

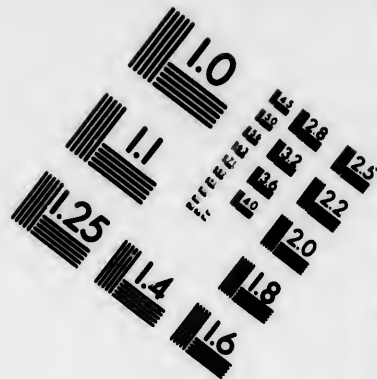
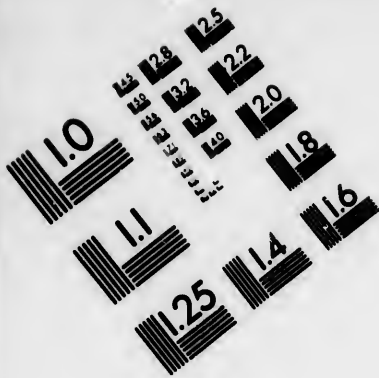

**IMAGE EVALUATION
TEST TARGET (MT-3)**

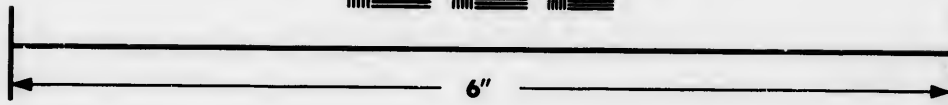
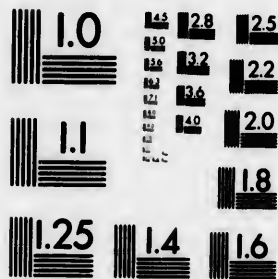

**Photographic
Sciences
Corporation**

23 WEST MAIN STREET
WEBSTER, N.Y. 14590
(716) 872-4503

18
20
22
25

10
11

BREAD BOARDS



No. 2686W

Diameter..... **11** **12** inch
 No. 2686W—Turned Maple, Carved "Bread" and Tree Branches per doz. **\$3.75** **4.90**

WATER FILTERS AND COOLERS



CHEAVIN'S FILTER



SUCCESS FILTER



WATER COOLER

CHEAVIN'S STONEWARE FILTERS

Nos	B	C	D	E
Size	2	4	6	8 gallons.
Each	\$7.50	9.00	12.75	18.00

SUCCESS STONEWARE FILTERS

No. 1—Success Filters, Capacity 4 gallons, with one Block and Plated Faucet..... each **\$5.00**
 Extra Blocks, for Success Filters, size 4 x 4 inch, with Drip Tube..... " **2.25**

These Blocks are of natural Tripoli stone, hollowed out on inside, fitted with rubber gaskets in bottom. Any barrel, tub or other water-tight receptacle can be converted into a practical filter by simply punching a hole in the bottom and attaching this tube and Block. Capacity of each Block, dependent upon the amount of water kept over it, and the muddiness of water, is from four to sixteen gallons per day.

WATER COOLERS

Size	2	3	4	6	10 gallons.
Japanned, Plated Faucets	each \$1.87	2.24	2.50	3.12	4.50

DRAM FLASKS



Style of Nos. 2672 to 4644

Style of Nos. 4599 to 2645

WITH DETACHABLE WHITE METAL CUP OVER SCREW CAP

Size		1/2	3/4	1	1 1/2	pints.
No. 2672	All White Metal	each	\$1.75	2.00	2.50	3.00
" 4672	" Electro-Plated	"	3.50	4.50	5.50	6.50
" 3644	Glass, Imitation Morocco Leather Covered, Stitched, with Window	"	1.25	1.40	1.65	2.00
" 4644	" Heavy Tan-Colored	"	1.80	2.10	2.25	3.85

WITH DETACHABLE WHITE METAL CUP

Size		1/2	3/4	1	1 1/4	1 1/2	2	pints.
No. 4599	Glass, Imitation Leather Covered, not Stitched	each	\$0.55	0.65	0.80
" 1645	" Morocco Leather Covered, Stitched, with Window	"	0.75	0.90	1.05	1.35	1.65	2.50
" 2645	" Heavy Tan-Colored Leather Covered, Stitched, with Window	"	1.25	1.50	1.65	1.90	2.20	3.00

COLLAPSIBLE DRINKING CUPS

Full size cuts.



No. 69

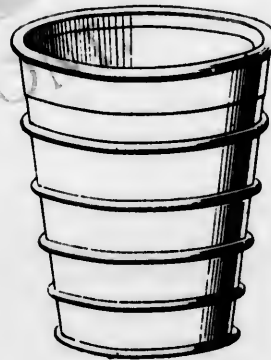

No. 7965

No. 69	Watch Case Pattern, Nickel-Plated	each	\$1.25
" 7965	White Metal, Nickel-Plated	"	0.60

BIRD CAGES

JAPPANED



No. 016
6½ x 8 inches.



No. 017
7½ x 10 inches.



No. 20
7½ x 7½ inches.



No. 76
7½ x 7½ inches.

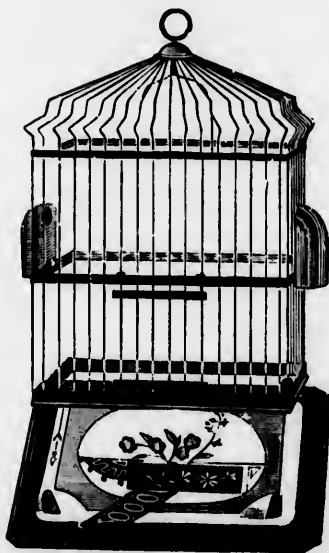

No. 106
9½ x 9½ inches.



No. 26
9 x 9 inches.

Complete, with Seed Cups, Swings and Perches.

Prices, see page 813.

BIRD CAGES

JAPANED



No. 77
8½ x 8½ inches.



No. 25
8 x 8 inches.



No. 020
8½ x 11½ inches.



No. 019
8 x 10½ inches.



No. 24
8 x 8 inches.



No. 78
8½ x 8½ inches.

No. 30—Case containing one dozen Japaned Cages, Assorted, Square and Oblong, Fancy Styles... per case \$15.25
Half cases, half price. No charge for cases.

MOUSE AND RAT TRAPS



Delusion Mouse Traps, Self-Setting per doz. \$2.20



Snap-Shot Wood Mouse Traps, 4 Holes per doz. 1.50



No. 20

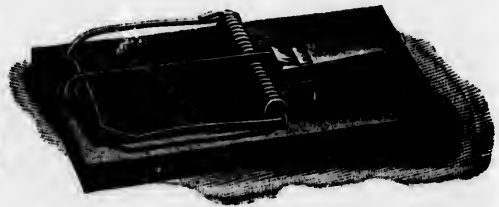

OUT OF SIGHT

No. 20—Knock-Out Mouse Traps, Iron Cross-Bars riveted to Wooden Back.....	per doz.	0.90
" 1—Out of Sight Mouse Traps.....	"	1.50
" 2— " " Rat Traps.....	"	3.00

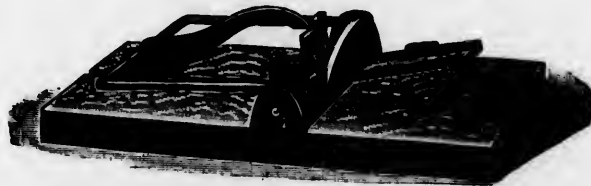

No. 500

No. 500—Knock-Out Rat Traps, Iron Cross-Bars riveted to Wooden Block per doz. 2.30

MOUSE AND RAT TRAPS



WOOD



METALLIC

Circular Wood Mouse Traps, 4 Holes	per doz.	\$1.10
" " " " 5 "	"	1.40
" Metallic " " 5 "	"	1.60

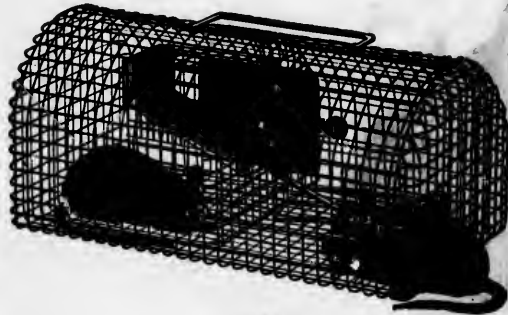

WIZARD



CAM LOCK

Wizard, Wire Mouse Traps, Self-Setting, 7 1/2 x 3 1/2 inches	per doz.	7.20
Cam Lock, Wire Rat Traps, Re-tinned, 11 x 6 "	"	0.50



YANKEE

Yankee, Wire Rat Traps, 18 x 8 inches	per doz.	10.20
---	----------	-------

HAIR CURLING IRONS



No. 3286



No. 3288

No. 3286-C—Bright, Varnished Handles, Diameter $\frac{1}{4}$ inch, Length 8 inches	per doz.	\$0.40
" 3286-S— " " " " $\frac{1}{4}$ " " 8 "	"	0.50
" 3288—Folding, Nickel-Plated, " " " $\frac{1}{4}$ " " 6 $\frac{1}{2}$ "	"	1.65



DUKE.
PAT. OCT. 6. 94.



LITTLE PRINCESS.
PAT. OCT. 6. 94.

Duke, Polished Steel, Nickel-Plated, Antique Oak Handles, Diameter $\frac{1}{4}$ inch, Length 6 inches	per doz.	0.70
No. C— " " (not plated), Polished Wood " " " $\frac{1}{4}$ " " 6 "	"	0.45
Little Princess, Polished Steel, Nickel-Plated, Antique Oak Handles, Diameter $\frac{1}{4}$ inch, Length 7 $\frac{1}{2}$ in. "	"	0.85
No. B—Polished Steel (not plated), Polished Wood Handles, Diameter $\frac{1}{4}$ inch, Length 7 $\frac{1}{2}$ inches	"	0.55

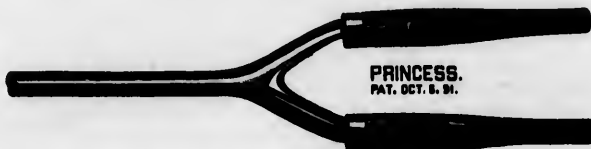

PRINCESS.
PAT. OCT. 6. 94.

Princess, Polished Steel, Nickel-Plated, Antique Oak Handles, Diameter $\frac{1}{4}$ inch, Length 9 $\frac{1}{2}$ inches ..	per doz.	0.90
No. A— " " (not plated), Polished Wood " " " $\frac{1}{4}$ " " 9 $\frac{1}{2}$ " .. "	"	0.70

WAVING IRONS



No. 5—Oriental Waving Irons, Length 10 $\frac{1}{2}$ inches	per doz.	2.65
" 10—Niagara " " " 10 $\frac{1}{2}$ "	"	2.25



LAMP HEATERS

WITH CURLING TONG ATTACHMENT

Daisy, Wire, Coppered	per doz.	1.20
Peerless, Polished Brass, Nickel-Plated	"	3.00

For Spirit Curling Tong Heaters, see page 303.

PINKING IRONS



DIAMOND TOOTH

Size.....	1/2	5/8	3/4	7/8	1	1 1/4	1 1/2	1 3/4	2 inch.
Diamond.....per doz.	\$1.15	1.15	1.15	1.15	1.15	2.05	2.05	3.00	3.75
Scallop....."	\$1.15	1.15	1.15	1.15	1.15
Straight....."	1.15	1.15	1.15	1.15

One dozen in a box.

MAT HOOKS



No. 7120



BENT SHANK

No. 7120—Bright, Round, Straight Shank, Plain Handle.....	per doz.	\$0.75
" 7122— " " " " Handle as Cut of Bent Shank.....	"	1.75
" 1093—Bright, Flat, Bent Shank, Handle as Cut of Bent Shank.....	"	1.15

One dozen in a box.

POT CLEANERS



SENSIBLE

CHAIN BURNISHERS

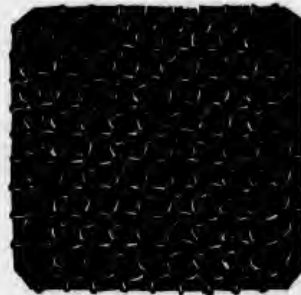

Mounted on Best Buff Leather.

Sensible, with Scraper and Chain.....per doz. \$1.35 | No. 1—Single Link, 4 x 4 inch.....per doz. \$4.00

CHAMOIS SKINS

Nos.....	B	D	E	F	G
Chamois Skins.....per doz.	\$5.05	5.90	3.40	2.05	2.10

LANTERNS

HAM'S



GEM



No. 18, DRIVING

No. 00—Gem, Solid Brass, 1/4 inch Wick	per doz.	\$13.50
" 100— " " Nickel-Plated, 1/4 inch Wick	"	17.05
" 18— " Driving Lamp, Nickel-Plated on Brass, Copper Reflector, Silver-Plated, Bevel Plate Glass in Door, 1/4 inch Wick	"	54.00

POLICE DARK LANTERNS



Nos. 1 and 2



No. 33

No. 11—2 1/4 inch Lens, Height 7 inches, Japanned	per doz.	8.10
" 22—3 " " " 8 " "	"	9.75
" 33—Metropolitan Police Pattern, Heavy 3 inch Lens, Special Quality	"	18.00

LAMP AND LANTERN BURNERS



LAMP BURNERS

No.	A	B
Burner..... per doz.	\$1.05	1.45

LANTERN BURNERS

No.	0	39	20B
Per dozen.....	\$1.15	1.15	2.25

LAMP WICK

No.	O	A	B	D
Per gross.....	\$0.50	0.70	1.00	1.00

LANTERN BURNERS

No.	1	2
Rochester..... per gross	\$0.65	0.85

OIL STOVE WICK

Size.....	4	4 1/2	5 inch.
Per Gross.....	\$5.65	6.25	6.90

LANTERN GLOBES AND LAMP CHIMNEYS



LANTERN GLOBE



RAILROAD GLOBE



LAMP CHIMNEY

LANTERN GLOBES

Quantity in a Case.....	1	3	6	doz.
Plain White..... per doz.	\$0.85	0.75	0.70	
Ruby..... "	3.75	4.15		
Green..... "	3.40			
No. 2 Cold Blast..... "	1.10	1.00		
" Gem..... "	1.10			
Railroad..... "	1.30			

LAMP CHIMNEYS

No.	0	1	2
For Burners..... Nos.	0 or E	1 or A	2 or B
Diameter at Bottom.....	2	2 1/2	3
Dominion Best Lead... per doz.	\$0.51	0.53	0.75
Crown Fine Flint..... "	0.39	0.40	0.58
Second Quality..... "	0.39	0.40	0.58

Lamp Chimneys, Nos. 0 and 2, 6 doz. in a case; No. 1, 8 doz. Cases Extra, for Nos. 0, \$0.25, 1 and 2 \$0.40 each, net.

39 90B
.15 2.25

5 2
8.36

5 inch.
6.90

3
or B
3 inch.
75
68
68
ch, net.

FLAGS



UNION JACK



ROYAL STANDARD



RED ENSIGN

W. LEWIS & SON

(LIMITED)

No 30-34

KING ST EAST,

TORONTO,

CANADA.



CANADIAN



AMERICAN



BLUE ENSIGN



SCOTTISH STANDARD

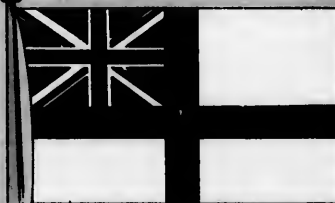

WHITE ENSIGN



IRISH STANDARD

Size, L
Each ..

Size, L
Red Do
Blue

Size, L
Each ...

Size, L
Each ..

Size....
Union J
Red Ens
White
Blue
Canada
Americ
Belgian
Scotch,
"

Length
Red Ens
Canada

18 inch
Per piec

Diamete
No. 87.
" 88-

Size....
Per doz

BUNTING FLAGS

Made of Best Quality Bunting.

RED, WHITE, OR BLUE ENSIGNS

Size, Length	1	1½	2	2½	3	3½	4	4½	5	6	7	8 yards.
Each	\$1.90	2.80	3.75	4.60	6.00	8.00	9.25	10.75	14.75	20.00	26.50	33.00

DOMINION ENSIGNS

Size, Length		2	2½	3	4	5	6	7	8 yards.
Red Dominion	each	\$5.50	8.00	9.50	13.50	18.50	23.00	33.00	38.00
Blue	"			9.50	13.50	18.50	23.00	33.00	

UNION JACKS

Size, Length	1	1½	2	2½	3	3½	4	4½	5 yards.
Each	\$2.00	3.25	4.50	6.25	7.75	9.75	13.25	16.50	20.00

SCOTCH STANDARDS

Size, Length	3	4	5 yards.
Each	\$18.50	23.50	31.00

AMERICAN ENSIGNS

Size, Length	2	2½	3	4	5 yards.
Each	\$4.50	6.25	7.75	13.25	20.00

COTTON FLAGS

Fast Colors, Hemmed Edges, Heavy Material.

Size	15x12	17x15	27x22	30x20	30x24	34x22	35x31	40x35	48x72	inch.
Union Jacks	per doz.	\$0.75	1.15	1.90		2.65		4.00	5.00	12.00
Red Ensigns	"	0.75	1.15	1.90		2.65				12.00
White	"	0.75				2.65				
Blue	"					2.65				
Canadian Ensigns	"						3.50			
American	"			2.50						
Belgian, French, German, Italian, Netherland, Russian, 27x22 inch	per doz.									\$3.00
Scotch, Irish and Royal Standards, 27x22 inch	"									1.90
" " " " 30x24 "	"									2.65

SILK FLAGS

Length	18	36	inch.
Red Ensigns	per doz.	\$9.00	30.00
Canadian Ensigns	"	9.00	30.00

National Flags can be supplied at about above prices.

BUNTINGS

18 inches wide	RED	BLUE	WHITE
Per piece of 40 yards	\$14.00	14.00	13.00

FLAG POLE HOLDERS



No. 87



No. 88

Diameter of Pole	¼	⅜	½	⅝	¾	1	1¼	1½	2	inch.
No. 87	per doz.	\$0.90	1.20	1.50	1.80	2.50				
" 88—Tinned	"						5.00	6.50	8.00	16.00

FLAG POLES

Turned, with Pointed Ends, Saw-cut half length for inserting Flag.

Size	3 ft. x ½ in.	4 ft. x ⅝ in.	6 ft. x ¾ in.
Per dozen	\$0.45	0.70	1.00

599 Duttony
D 1170

HENRY BOKER & CO.'S



TREE BRAND POCKET OUTLERY

H. BOKER & CO.'S productions are of the very highest quality, are made from the best English crucible cast steel, hardened and tempered by experienced workmen, and sent out ready for use. Care should be used in whetting a pocket knife, the blade being held at an angle of twenty degrees, and not laid flat on the stone like a razor. The joints should be kept oiled, or will wear rough and the blade points protrude.

TWO-BLADE PENKNIVES

Full size cuts.

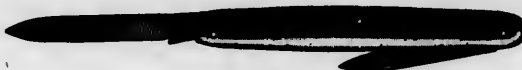

No. 8257

No. 8257—Ivory Handle, 2 Blades, Brass Lined	per doz.	\$4.05
" 8258—Pearl " 2 " "	"	7.00



No. 8577

No. 8577—Ivory Handle, 2 Blades, Brass Lined, German Silver Bolsters	per doz.	4.80
--	----------	------



No. 8618

No. 8617—Ivory Handle, 2 Blades, Brass Lined, German Silver Bolsters	per doz.	5.80
" 8618—Pearl " 2 " "	"	9.00



No. 8598

No. 8598—Ivory Celluloid Handle, 2 Blades, Brass Lined, German Silver Bolsters	per doz.	5.10
" 8598—Pearl Handle, 2 Blades, Brass Lined, German Silver Bolsters	"	6.80



No. 8803

No. 8803—Grey Buff Handle, 2 Blades, Brass Lined, German Silver Bolsters	per doz.	5.55
--	----------	------

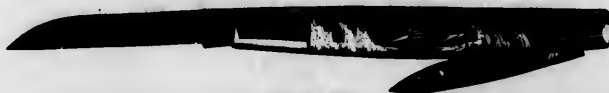

No. 8808

No. 8808—Pearl Handle, 2 Blades, Brass Lined, German Silver Bolsters	per doz.	6.80
--	----------	------

BOKER'S POCKET KNIVES

Full size cuts.



No. 8270

No. 8270—Light Bronze Handle, 2 Blades, the reverse side of Handle same pattern as No. 8270½ per doz. \$5.75

\$6.10
8.30

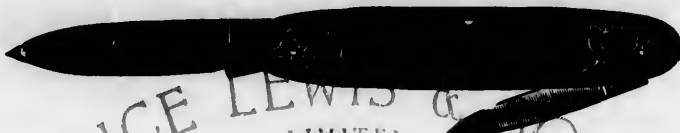

No. 8270½

No. 8270½—Light Bronze Handle, 2 Blades, the reverse side of Handle same pattern as No. 8270 per doz. 5.00

9.85



No. 8280

No. 8280—Blue Bronze Handle, 2 Blades, the reverse side of Handle same pattern as No. 8280½ per doz. 5.75

11.35



No. 8280½

No. 8280½—Blue Bronze Handle, 2 Blades, the reverse side of Handle same pattern as No. 8280 per doz. 5.00

6.60
6.00
10.35

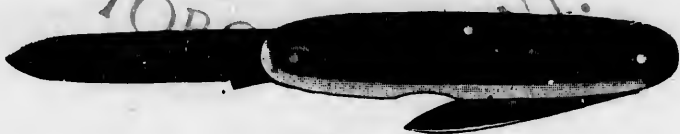

No. 8696

No. 8696—Ivory Celluloid Handle, 2 Blades, Brass Lined per doz. 5.30

5.00



No. 8650

No. 8650—German Silver Handle, 2 Blades per doz. 5.00

3.10

BOKER'S POCKET KNIVES

Full size cuts.



No. 8686

No. 8683—Grey Buff Handle, 2 Blades, Brass Lined per doz. \$4.50
 " 8686—Ivory Celluloid " 2 " " " 4.50



No. 8452

No. 8452—Black Buff Handle, 2 Blades, Brass Lined per doz. 4.50
 " 8455—White Bone " 2 " " " 4.50

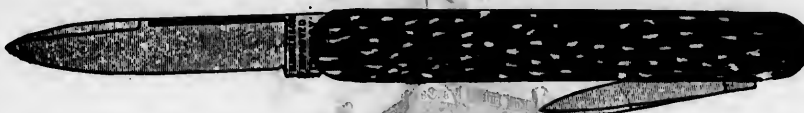

No. 8454

No. 8454—Stag Handle, 2 Blades, Brass Lined per doz. 4.30

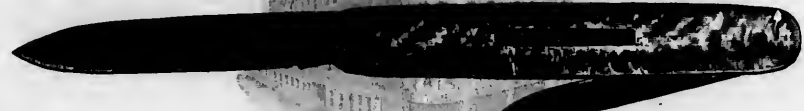

No. 8968

No. 8968—Pearl Handle, 2 Blades, German Silver Lined, Special Fine Finish per doz. 17.40



No. 8706

No. 8706—Ivory Celluloid Handle, 2 Blades, Brass Lined per doz. 5.90



No. 8495

No. 8492—Black Buff Handle, 2 Blades, Brass Lined, German Silver Bolsters per doz. 6.20
 " 8494—Stag " 2 " " " " " " 6.20
 " 8495—White Bone " 2 " " " " " " 6.20

RICE LEWIS & SON
 LIMITED

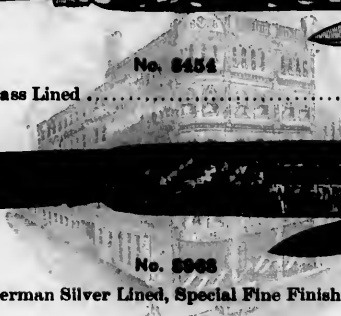

\$6.00

4.00
4.00

4.55

4.50

6.25
6.60
11.90

4.30
4.30

BOKER'S POCKET KNIVES

Full size cuts.



No. 8498

No. 8498—Pearl Handle, 2 Blades, Brass Lined, German Silver Bolsters per doz. **\$12.85**



No. 8722

No. 8722—Black Buff Handle, 2 Blades, Brass Lined, German Silver Bolsters per doz. **5.30**

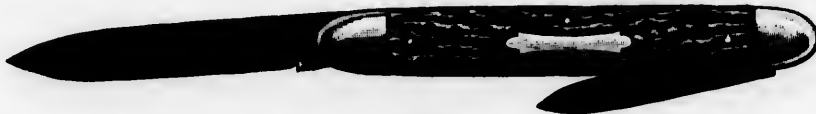

No. 8584

No. 8584—Stag Handle, 2 Blades, Brass Lined, German Silver Bolsters per doz. **5.65**



No. 8582

No. 8582—Black Buff Handle, 2 Blades, Brass Lined, German Silver Bolsters per doz. **5.90**
“ 8585—White Bone “ 2 “ “ “ “ “ “ **5.80**



No. 8662

No. 8662—Black Buff Handle, 2 Blades, Brass Lined per doz. **5.90**



No. 8648

No. 8648—Black Buff Handle, 2 Blades, Brass Lined, German Silver Bolsters per doz. **7.00**
“ 8645—White Bone “ 2 “ “ “ “ “ “ **7.00**
“ 8648—Pearl “ 2 “ “ “ “ “ “ **12.25**

BOKER'S POCKET KNIVES

Full size cuts.



No. 8486

No. 8484—Stag Handle, 2 Blades, Brass Lined, German Silver Bolsters.....per doz. \$7.50
 " 8486—Ivory Celluloid Handle, 2 Blades, Brass Lined, German Silver Bolsters..... " 8.40



No. 8334

No. 8334—Stag Handle, 2 Blades, Brass Lined, German Silver Bolsters.....per doz. 7.70



No. 8376

No. 8376—Ivory Celluloid Handle, 2 Blades, Brass Lined, German Silver Bolsters.....per doz. 8.25

THREE-BLADE PENKNIVES

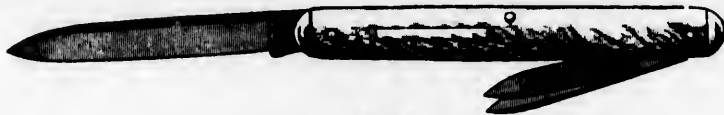

No. 83438

No. 83438—Pearl Handle, 3 Blades, Brass Lined, German Silver Bolsters.....per doz. 13.05

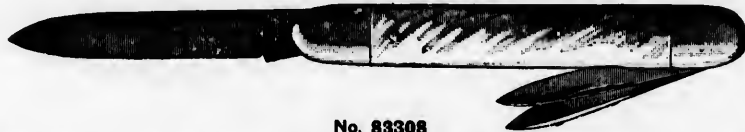

No. 83308

No. 83308—Pearl Handle, 3 Blades, Brass Lined, German Silver Bolsters.....per doz. 10.90

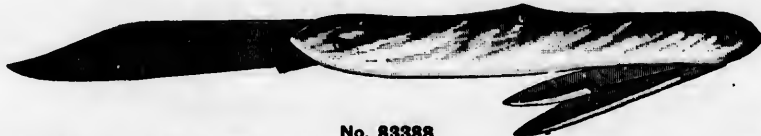

No. 83388

No. 83388—Pearl Handle, 3 Blades, Brass Lined.....per doz. 18.30

BOKER'S POCKET KNIVES

Full size cuts.



No. 83898

No. 83898—Pearl Handle, 3 Blades, Brass Lined, German Silver Bolsters.....per doz. \$14.40



No. 83882

No. 83882—Black Buff Handle, 3 Blades, Brass Lined, German Silver Bolsters.....per doz. 7.95



No. 83854

No. 83854—Stag Handle, 3 Blades, Brass Lined, German Silver Bolsters.....per doz. 7.85



No. 83858

No. 83858—Pearl Handle, 3 Blades, Brass Lined, German Silver Bolsters.....per doz. 10.35



No. 83880

No. 83880—Aluminum Handle, 3 Blades.....per doz. 8.85

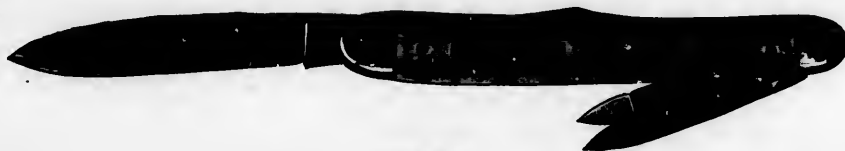

No. 83867

No. 83867—Ivory Handle, 3 Blades, Brass Lined, German Silver Bolsters.....per doz. 10.45

87.50
8.40

7.70

8.25

13.95

10.90

18.90

BOKER'S POCKET KNIVES

Full size cuts.



No. 84848

No. **84848**—Pearl Handle, 4 Blades, Brass Lined, German Silver Bolstersper doz. **\$11.80**



No. 84844

No. **84844**—Stag Handle, 4 Blades, Brass Lined, German Silver Bolstersper doz. **9.05**



No. 84858

No. **84857**—Ivory Handle, 4 Blades, Brass Lined, German Silver Bolstersper doz. **11.90**
 " **84858**—Pearl " 4 " " " " " " " **22.50**



No. 84958

No. **84958**—Pearl Handle, 4 Blades, Brass Lined, German Silver Bolstersper doz. **16.65**



No. 84917

No. **84914**—Stag Handle 4 Blades, Brass Lined, German Silver Bolstersper doz. **11.90**
 " **84917**—Ivory " 4 " " " " " " " **11.90**

BOKER'S POCKET KNIVES

Full size cuts.



No. 85588

85578

85593

85607

85617 and 85618

- | | | |
|--|----------|---------|
| No. 85588—Pearl Handle, 4 Blades, Picker, Nail File and Scissors, German Silver Lined, Special Fine Finish | per doz. | \$51.75 |
| " 85578—Pearl Handle, 2 Blades, Button Hook, Nail File, Cork Screw and Scissors, Brass Lined, German Silver Bolsters | per doz. | 49.00 |
| " 85593—Grey Buff Handle, 2 Blades and Cork Screw, Brass Lined | " | 10.15 |
| " 85607—Ivory Handle, 3 Blades, Button Hook, Cork Screw and Nail File, Brass Lined | " | 25.25 |
| " 85617— " " 2 " Wire Cutter and Cork Screw, Brass Lined, G. S. Bolsters | " | 20.70 |
| " 85618—Pearl " " 2 " " " " " " | " | 23.45 |

BOKER'S POCKET KNIVES

Full size cuts.



Nos. 85644

85627 and 85628

85633

85500

No. 85644—Stag Handle, 4 Blades, Saw and Cork Screw, Brass Lined, G. S. Bolsters	per doz.	\$38.00
" 85627—Ivory " 2 " Wire Cutter and Cork Screw, Brass Lined, G. S. Bolsters	"	31.00
" 85628—Pearl " 2 " " " " " " " " " " " "	"	30.90
" 85633—Grey Buff Handle, 4 Blades, Saw Blade and Cork Screw, Brass Lined, G. S. Bolsters ..	"	28.15
" 85500—German Silver Handle, 2 Blades, Wire Cutter and Cork Screw	"	11.25

BOKER'S POCKET KNIVES

Full size cuts.



No. 81002

No. 81002—Ebony Handle, 1 Blade, Iron Lined and Bolsterper doz. \$3.85



No. 81012

No. 81012—Ebony Handle, 1 Blade, Iron Lined and Bolsterper doz. 4.10



No. 81022

No. 81022—Ebony Handle, 1 Blade, Iron Lined and Bolsterper doz. 4.85



No. 81032

No. 81032—Ebony Handle, 1 Blade, Iron Lined and Bolsterper doz. 5.55



No. 81812

No. 81812—Ebony Handle, 1 Blade, Iron Lined and Bolsterper doz. 3.95



No. 81832

No. 81832—Ebony Handle, 1 Blade, Iron Lined and Bolsterper doz. 4.25

z. \$38.00
\$1.00
\$0.00
\$8.15
11.25

BOKER'S POCKET KNIVES

Full size cuts.



No. 81842

No. 81842—Ebony Handle, 1 Blade, Iron Lined and Bolster.....per doz. \$5.20



No. 81852

No. 81852—Ebony Handle, 1 Blade, Iron Lined and Bolster.....per doz. 5.80

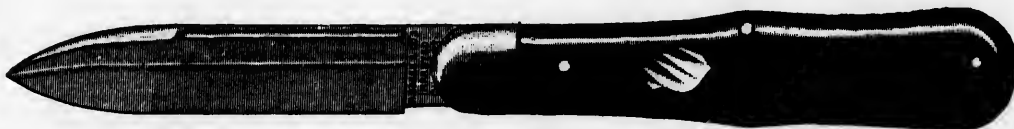

No. 81502

No. 81502—Ebony Handle, 1 Strong Bevelled Blade, Iron Lined and Bolster.....per doz. 0.25



No. 82002

No. 82002—Ebony Handle, 2 Blades, Iron Lined and Bolster.....per doz. 5.00



No. 82012

No. 82012—Ebony Handle, 2 Blades, Iron Lined and Bolster.....per doz. 5.35



No. 82022

No. 82022—Ebony Handle, 2 Blades, Iron Lined and Bolster.....per doz. 6.25

BOKER'S POCKET KNIVES

Full size cuts.



No. 82032

No. 82032—Ebony Handle, 2 Blades, Iron Lined and Bolster per doz. \$7.15



No. 82812

No. 82812—Ebony Handle, 2 Blades, Iron Lined and Bolster per doz. 5.00



No. 82832

No. 82832—Ebony Handle, 2 Blades, Iron Lined and Bolster per doz. 5.05

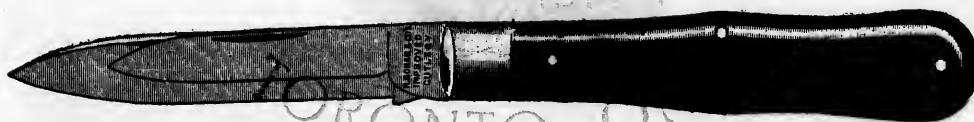

No. 82842

No. 82842—Ebony Handle, 2 Blades, Iron Lined and Bolster per doz. 6.70

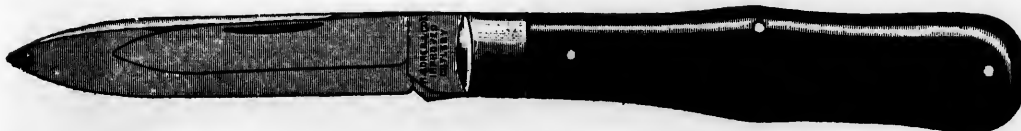

No. 82852

No. 82852—Ebony Handle, 2 Blades, Iron Lined and Bolster per doz. 7.00

BOKER'S POCKET KNIVES

Full size cuts.

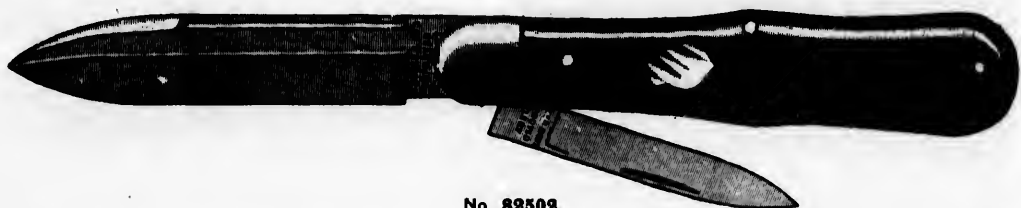

No. 82502

No. 82502—Ebony Handle, 2 Blades, Large Blade Heavy, Bevelled, Iron Lined and Bolster..... per doz. \$7.85

H. BOKER & CO.'S "KING CUTTER" KNIVES

Blades English Crucible Cast Steel, Hand Forged, Carefully Tempered, Mirror Polished.



No. 01012

No. 01012—Ebony Handle, 1 Blade, Iron Lined and Bolster..... per doz. 6.00



No. 01592

No. 01592—Ebony Handle, 1 Blade, Iron Lined and Bolster..... per doz. 5.20



No. 02012

No. 02012—Ebony Handle, 2 Blades, Iron Lined and Bolster..... per doz. 6.35

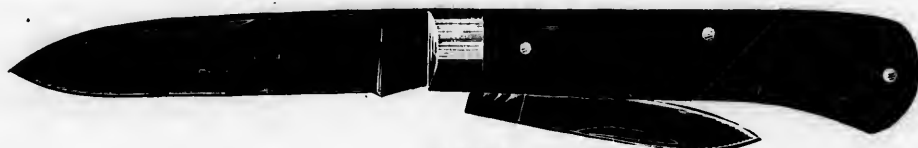

No. 02592

No. 02592—Ebony Handle, 2 Blades, Iron Lined and Bolster..... per doz. 6.90

BOKER'S POCKET KNIVES

Full size cuts.



No. 02833

No. 02833—Grey Buff Handle, 2 Blades, Brass Lined, German Silver Bolsters.....per doz. \$8.75



No. 02022

No. 02022—Ebony Handle, 2 Blades, Iron Lined and Bolsterper doz. 7.70



No. 02032

No. 02032—Ebony Handle, 2 Blades, Iron Lined and Bolsterper doz. 8.40



No. 02843

No. 02843—Grey Buff Handle, 2 Blades, Brass Lined, German Silver Bolstersper doz. 9.65



No. 02853

No. 02853—Grey Buff Handle, 2 Blades, Brass Lined, German Silver Bolstersper doz. 11.25

THOMAS TURNER & CO'S

POCKET  MARK. **OUTLERY**
ENCORE

TWO-BLADE PENKNIVES



Nos. 9216 and 9218



No. 9318

No. 9216—2 inch, Ivory Celluloid Handle, 2 Blades, Brass Lined, German Silver Bolsters	per doz.	\$ 7.10
" 9218—2 " Pearl " 2 " " " " " " " " " " " " " " " " "	"	8.45
" 9318—2 1/2 " " " 2 " " " " " " " " " " " " " " " " " " "	"	10.15



Nos. 9206 and 9208



Nos. 9226 and 9228



No. 9306 and 9308

No. 9206—2 inch, Ivory Celluloid Handle, 2 Blades, Brass Lined, German Silver Bolsters	per doz.	7.45
" 9208—2 " Pearl " 2 " " " " " " " " " " " " " " " " " " "	"	8.45
" 9226—2 " Ivory Celluloid " 2 " " " " " " " " " " " " " " " " " " "	"	7.10
" 9228—2 " Pearl " 2 " " " " " " " " " " " " " " " " " " "	"	8.10
" 9306—2 " Ivory Celluloid " 2 " " " " " " " " " " " " " " " " " " "	"	6.10
" 9308—2 " Pearl " 2 " " " " " " " " " " " " " " " " " " "	"	7.10



Nos. 9287 and 9288



No. 9298

No. 9287—2 1/2 inch, Ivory Handle, 2 Blades, Brass Lined, German Silver Bolsters	per doz.	12.50
" 9288—2 1/2 " Pearl " 2 " " " " " " " " " " " " " " " " " " "	"	10.20
" 9298—2 1/2 " " " 2 " " " " " " " " " " " " " " " " " " "	"	10.20



Nos. 9230 and 9250



Nos. 9240 and 9260

No. 9230—2 1/2 inch, German Silver Handle, 2 Blades	per doz.	8.40
" 9250—2 1/2 " Sterling " 2 " " " " " " " " " " " " " " " " " " "	"	24.30
" 9240—2 1/2 " German " Engine Turned, 2 Blades	"	13.50
" 9260—2 1/2 " Sterling " " 2 " " " " " " " " " " " " " " " " " " "	"	23.36



No. 9540



No. 9550

No. 9540—2 1/2 inch, German Silver Handle, 2 Blades	per doz.	6.40
" 9550—3 " " " 2 " " " " " " " " " " " " " " " " " " "	"	6.40

TURNER'S POCKET KNIVES



No. 9578



Nos. 9588 and 9588

No. 9568	—2½ inch, Pearl Handle, 2 Blades, Brass Lined, German Silver Bolsters	per doz.	\$ 9.45
" 9578	—2½ " " " 2 " " " " " "		13.50
" 9588	—3½ " " " 2 " " " " " "		10.80



No. 9454. Two-thirds size cut.

No. 9443	—3 inch, Grey Buff Handle, 2 Blades, Brass Lined	per doz.	5.75
" 9444	—3 " " Stag " 2 " " " " " "		5.75
" 9446	—3 " " Ivory Celluloid " 2 " " " " " "		5.75
" 9448	—3 " " Pearl " 2 " " " " " "		10.80
" 9449	—3 " " Shell " 2 " " " " " "		5.75
" 9453	—3½ " " Grey Buff " 2 " " " " " "		6.10
" 9454	—3½ " " Stag " 2 " " " " " "		6.10
" 9456	—3½ " " Ivory Celluloid " 2 " " " " " "		6.10
" 9458	—3½ " " Pearl " 2 " " " " " "		12.85
" 9459	—3½ " " Shell " 2 " " " " " "		6.10
" 9463	—3½ " " Grey Buff " 2 " " " " " "		6.45



Nos. 9614 and 9616

No. 9614	—3½ inch, Stag Handle, 2 Blades, German Silver Lined	per doz.	22.05
" 9616	—3½ " " Pearl " 2 " " " " " "		31.05



No. 9476

No. 9473	—3½ inch, Grey Buff Handle, 2 Blades, Brass Lined, German Silver Bolsters	per doz.	8.10
" 9476	—3½ " " Ivory Celluloid " 2 " " " " " "		8.10
" 9478	—3½ " " Pearl " 2 " " " " " "		14.85



Nos. 9407 and 9408

No. 9407	—2½ inch, Ivory Handle, 2 Blades, Brass Lined, German Silver Bolsters	per doz.	10.15
" 9408	—2½ " " Pearl " 2 " " " " " "		13.50
" 9417	—3½ " " Ivory " 2 " " " " " "		10.80
" 9418	—3½ " " Pearl " 2 " " " " " "		12.85



Nos. 9417 and 9418



No. 9533

No. 9533	—3½ inch, Grey Buff Handle, 2 Blades, Brass Lined, German Silver Bolsters	per doz.	9.15
----------	---	----------	------

TURNER'S POCKET KNIVES



No. 9323

No. 9323 —3½ inch, Grey Buff Handle, 2 Blades, Brass Lined, German Silver Bolsters.....	per doz. \$7.45
“ 9324 —3½ “ Stag “ 2 “ “ “ “ “ “ “	“ 9.45



No. 9608

No. 9608 —3¼ inch, Pearl Handle, 2 Blades, Brass Lined, German Silver Bolsters.....	per doz. 28.35
--	----------------



No. 9278

No. 9278 —2½ inch, Pearl Handle, 2 Blades, Brass Lined.....	per doz. 16.90
--	----------------

THREE-BLADE PENKNIVES



Nos. 93636 and 93638

No. 93636 —3¼ inch, Ivory Celluloid Handle, 3 Blades, Brass Lined, German Silver Bolsters.....	per doz. 12.85
“ 93638 —3¼ “ Pearl “ 3 “ “ “ “ “ “ “	“ 18.00



Nos. 93626 and 93628

No. 93626 —3¼ inch, Ivory Celluloid Handle, 3 Blades, Brass Lined, German Silver Bolsters.....	per doz. 16.20
“ 93628 —3¼ “ Pearl “ 3 “ “ “ “ “ “ “	“ 24.30



Nos. 93647 and 93648

No. 93647 —3¼ inch, Ivory Handle, 3 Blades, Brass Lined.....	per doz. 31.05
“ 93648 —3¼ “ Pearl “ 3 “ “ “ “ “ “ “	“ 41.85

TURNER'S POCKET KNIVES



No. 93334

No. 93323	3 3/4 inch, Grey Buff Handle, 3 Blades, Brass Lined, German Silver Bolsters.	per doz.	\$10.80
" 93324	3 3/4 " Stag " 3 " " " " " " " " " "		10.80
" 93334	4 " " " 3 " " " " " " " " " "		17.55

doz. \$7.45
9.45



No. 93924

No. 93924	3 3/4 inch, Stag Handle, 3 Blades, Brass Lined, German Silver Bolsters	per doz.	18.25
-----------	--	----------	-------

doz. 28.35



No. 93914

No. 93914	3 3/4 inch, Stag Handle, 3 Blades, Brass Lined, German Silver Bolsters	per doz.	17.55
-----------	--	----------	-------

doz. 18.00



No. 93902

No. 93902	4 1/4 inch, Buff Handle, 3 Blades, Brass Lined, German Silver Bolsters	per doz.	20.25
-----------	--	----------	-------

doz. 12.85
18.00

FOUR-BLADE PENKNIVES



No. 94578

No. 94578	3 inch, Pearl Handle, 4 Blades, Brass Lined, German Silver Bolsters	per doz.	20.25
-----------	---	----------	-------

31.05
41.85

TURNER'S POCKET KNIVES



No. 94658

No. 94650—3½ inch, German Silver Handle, Brass Lined	per doz.	\$24.30
" 94657—3½ " Ivory Handle, Brass Lined	"	30.40
" 94658—3½ " Pearl " "	"	33.75

FIVE-BLADE PENKNIVES

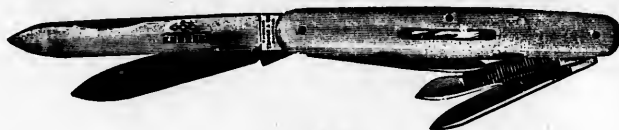

No. 95667

No. 95667—3½ inch, Ivory Handle, 5 Blades (1 Spear, 2 Pen, 1 Nail, 1 Sterling Fruit Blade,) German Silver Lined	per doz.	61.80
---	----------	-------

CYCLIST'S KNIFE



No. 95800

No. 95800—3½ inch Aluminum Handle, Large Spear Blade, Turn Screw and Tire Detacher.	per doz.	17.20
--	----------	-------

SCISSOR KNIVES



No. 95814

No. 95814—3½ inch, Stag Handle, 2 Blades and Scissors, Brass Lined, German Silver Bolsters.	per doz.	31.00
--	----------	-------



No. 95828

No. 95828—2½ inch, Pearl Handle, 1 Blade and Scissors, Brass Lined.	per doz.	22.95
--	----------	-------

TURNER'S POCKET KNIVES

COMBINATION KNIVES



No. 95838

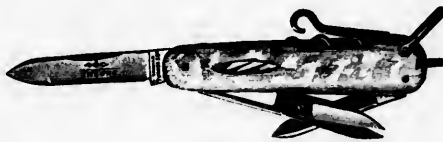

No. 95848

- No. 95838—3 inch, Pearl Handle, 2 Blades, Button Hook and Cigar Holder.....per doz. \$48.00
 " 95848—2½ " " 2 " " Scissors, Cork Screw, Tweezers and Picker, " 68.85

RICE LEWIS & SON
 LIMITED



No. 95858

- No. 95858—2½ inch, Pearl Handle, 2 Blades, Button Hook and Scissors, Brass Lined.....per doz. 20.25



Nos. 95860 to 95880

- No. 95860—2½ inch, German Silver Handle, 2 Blades, Cork Screw and Button Hookper doz. 19.00
 " 95870—2½ " " " 1 " " Button Hook and Scissors..... " 23.05
 " 95880—2½ " " " 2 " " and Nail File..... " 19.60

TORONTO

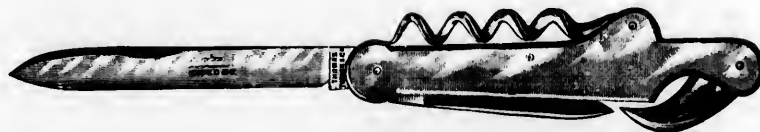

No. 95890

- No. 95890—4 inch, German Silver Handle, 2 Blades, Cork Screw and Wire Cutterper doz. 24.30

TURNER'S POCKET KNIVES



No. 95910

No. 95910—3½ inch, German Silver Handle, 1 Blade, Cork Screw and Wire Cutter per doz. \$14.85

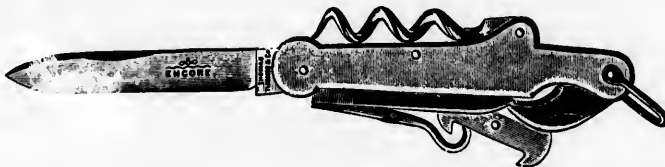

No. 95900

No. 95900—3½ inch, German Silver Handle, 2 Blades, Button Hook, Cork Screw, Wire Cutter, and Extractor per doz. 33.75



No. 95924

No. 95924—3 inch, Stag Handle, 2 Blades, Hoof Hook, Cork Screw, Reamer, Tweezers and Picker .. per doz. 14.85

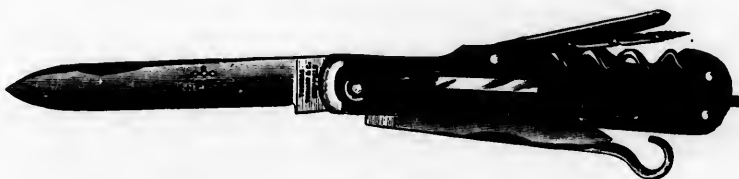

No. 95934

No. 95934—5¼ Inch, Stag Handle with Shackle, 1 Long Blade 4¼ inches, 1 Small Blade 2¼ inches, Saw, Cork Screw, Gimlet, Reamer, Tweezers and Picker..... per doz. 85.05

TURNER'S POCKET KNIVES

YACHTSMAN'S KNIFE



No. 95920

No. **95920**—4½ inch, German Silver Handle, with Swivel Shackle, 1 Large Blade, Cork Screw and Marline Spike with Spring Lock.....per doz. **\$60.75**



No. 92924

No. **92924**—3½ inch, Stag Handle, 1 Blade and Timber Scribe, Iron Lined and Bolsterper doz. **14.85**

ONE-BLADE POCKET KNIVES

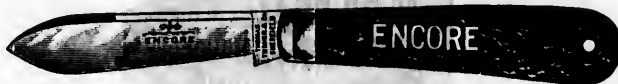

No. 91280

No. **91280**—3½ inch, Iron Handle, 1 Bladeper doz. **3.05**



No. 91062. Two-third size cut.

No. 91052 —3 inch, Buff Handle, 1 Blade, Iron Lined and Bolster.....per doz.	3.40
" 91061 —3½ " Cocoa " 1 " " " " " " " " " "	3.55
" 91062 —3½ " Buff " 1 " " " " " " " " " "	3.55
" 91072 —3½ " " " 1 " " " " " " " " " "	4.55



No. 91032. Two-third size cut.

No. 91002 —3 inch, Buff Handle, 1 Blade, Iron Lined and Bolster.....per doz.	3.40
" 91032 —3½ " " " 1 " " " " " " " " " "	4.05
" 91032 —3½ " " " 1 " " " " " " " " " "	4.75

TURNER'S POCKET KNIVES



No. 91302

No. 91302—3½ inch, Buff Handle, 1 Blade, Iron Lined and Bolster, Fisherman's Knife..... per doz. \$3.40



No. 91294

No. 91294—3½ inch, Stag Handle, 1 Blade, Iron Lined and Bolster, Drilled per doz. 3.25



No. 91312

No. 91312—3½ inch, Buff Handle, 1 Blade, Iron Lined and Bolster, Drilled per doz. 3.40



No. 91322

No. 91322—4½ inch, Buff Handle, 1 Blade, Iron Lined and Bolster, Drilled per doz. 5.75



No. 91272

No. 91272—4 inch, Buff Handle, 1 Blade, Iron Lined, German Silver Bolster, Drilled per doz. 6.95

TWO-BLADE POCKET KNIVES



No. 92072. Two-thirds size cut.

No. 92061 —3½ inch, Cocoa Handle, 2 Blades, Iron Lined and Bolster	per doz.	5.75
“ 92062 —3½ “ Buff “ 2 “ “	“	5.75
“ 92071 —3½ “ Cocoa “ 2 “ “	“ with Name Plate	6.00
“ 92072 —3½ “ Buff “ 2 “ “	“	6.00

No. 920
 “ 920
 “ 920
 “ 920
 “ 920
 “ 920
 “ 920
 “ 920
 “ 920

No. 922

No. 922

No. 921
 “ 921

No. 921

TURNER'S POCKET KNIVES



No. 92032. Two-third size cut.

doz.	\$3.40	No. 92002—3 inch, Buff Handle, 2 Blades, Iron Lined and Bolster.....	per doz.	\$5.10
		" 92005—3 " White Bone Handle, 2 Blades, Iron Lined and Bolster.....	"	5.10
		" 92012—3½ " Buff " " 2 " " " " " " " " " " " "	"	5.75
		" 92015—3½ " White Bone " " 2 " " " " " " " " " " " "	"	5.75
		" 92022—3½ " Buff " " 2 " " " " " " " " " " " "	"	5.90
		" 92025—3½ " White Bone " " 2 " " " " " " " " " " " "	"	5.90
		" 92032—3½ " Buff " " 2 " " " " " " " " " " " "	"	6.75
		" 92035—3½ " White Bone " " 2 " " " " " " " " " " " "	"	6.75
		" 92042—4 " Buff " " 2 " " " " " " " " " " " "	"	7.85
		" 92045—4 " White Bone " " 2 " " " " " " " " " " " "	"	7.85

RICE LEWIS & SON LIMITED



No. 92232

doz.	3.40	No. 92232—4 inch, Buff Handle, 2 Blades, Brass Lined, German Silver Bolster	per doz.	11.15
------	------	---	----------	-------



No. 92253

doz.	5.75	No. 92253—3½ inch, Grey Buff Handle, 2 Blades, Brass Lined, German Silver Bolsters.....	per doz.	8.90
------	------	---	----------	------



No. 92132. Two-third size cut.

doz.	6.05	No. 92122—3½ inch, Buff Handle, 2 Blades, Iron Lined and Bolster.....	per doz.	6.10
		" 92132—3½ " " " 2 " " " " " " " " " " " "	"	6.75



No. 92280

doz.	5.75 5.75 6.60 6.60	No. 92280—½ inch, Iron Handle, 2 Blades, Drilled	per doz.	5.10
------	------------------------------	--	----------	------

GEORGE WOSTENHOLM & SON'S

I-XL

POCKET OUTLERY

TWO-BLADE PENKNIVES

Full size cuts.



No. 5528

No. 5527-2½ inch, Ivory Handle, 2 Blades, Brass Lined.....	per doz.	\$5.85
" 5528-2½ " Pearl " 2 " "	"	8.00



No. 5547

No. 5547-2½ inch, Ivory Handle, 2 Blades, Brass Lined, German Silver Bolsters.....	per doz.	11.40
" 5548-2½ " Pearl " 2 " " "	"	15.00



No. 5517

No. 5517-2½ inch, Ivory Handle, 2 Blades, Brass Lined, German Silver Bolster.....	per doz.	7.45
" 5518-2½ " Pearl " 2 " " "	"	9.45



No. 5443

No. 5443-3 inch, Grey Buff Handle, 2 Blades, Brass Lined.....	per doz.	6.50
" 5443½-3 " " " 2 " " with Nail Blade.....	"	6.50
" 5444-3 " Stag " 2 " "	"	6.50
" 5447-3 " Ivory " 2 " "	"	6.50
" 5447½-3 " " " 2 " " with Nail Blade.....	"	6.50
" 5448-3 " Pearl " 2 " "	"	11.10
" 5448½-3 " " " 2 " " with Nail Blade.....	"	11.10



No. 5453

No. 5453-3½ inch, Grey Buff Handle, 2 Blades, Brass Lined.....	per doz.	6.70
" 5454-3½ " Stag " 2 " "	"	6.70
" 5457-3½ " Ivory " 2 " "	"	6.70
" 5458-3½ " Pearl " 2 " "	"	11.40

WOSTENHOLM'S POCKET KNIVES

THREE-BLADE PENKNIVES

Full size cuts.



No. 53818

No. 53814—3 $\frac{1}{8}$ inch, Stag Handle, 3 Blades, Brass Lined, German Silver Bolsters.....per doz. \$17.25
" 53818—3 $\frac{1}{8}$ " Pearl " 3 " without Name Plate, pattern as No. 53814..... " 23.10



No. 53717

No. 53717—3 $\frac{1}{8}$ inch, Ivory Handle, 3 Blades, Brass Lined, German Silver Bolsters.....per doz. 12.05



No. 53588

No. 53587—3 $\frac{3}{8}$ inch, Ivory Handle, 3 Blades, Brass Lined, German Silver Bolsters.....per doz. 13.00
" 53588—3 $\frac{3}{8}$ " Pearl " 3 " " " " " " " " " " 17.55

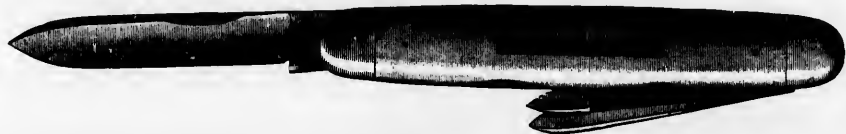

No. 53597

No. 53594—3 $\frac{1}{8}$ inch, Stag Handle, 3 Blades, Brass Lined, German Silver Bolsters.....per doz. 18.55
" 53597—3 $\frac{1}{8}$ " Ivory " 3 " " " " " " " " 18.20
" 53627—3 $\frac{1}{8}$ " " " (Heavy Oval), 3 Blades, Brass Lined, German Silver Bolsters.... " 20.80
" 53628—3 $\frac{1}{8}$ " Pearl " " 3 " " " " " " " " 24.70

WOSTENHOLM'S POCKET KNIVES

THREE-BLADE POCKET KNIVES

Full size cuts.



Nos. 53822 and 53824



Nos. 53832 to 53844



No. 53854

No.	53822	- 3 1/2	inch,	Buff	Handle,	3	Blades,	Brass	Lined,	German	Silver	Bolsters.	per	doz.	\$15.00
"	53824	- 3 1/2	"	Stag	"	3	"	Iron	Lined	and	Bolster.	"	"	15.30	
"	53832	- 3 1/2	"	Buff	"	3	"	Brass	Lined,	German	Silver	Bolsters.	"	17.25	
"	53834	- 3 1/2	"	Stag	"	3	"	"	"	"	"	"	"	19.35	
"	53836	- 3 1/2	"	Pearl	"	3	"	"	"	"	"	"	"	23.60	
"	53841	- 4	"	Stag	"	3	"	Full	Polished,	Brass	Lined,	German	Silver	Bolsters.	24.70
"	53854	- 4 1/2	"	Stag	"	3	"	Brass	Lined,	German	Silver	Bolsters.	"	27.30	

doz. \$17.25
" 23.10

doz. 12.05

loz. 13.00
17.55

oz. 18.55
18.20
20.80
24.70

RICE & SONS & SONS
ED & SONS

TORONTO, ONT.

WOSTENHOLM'S POCKET KNIVES

Full size cuts.

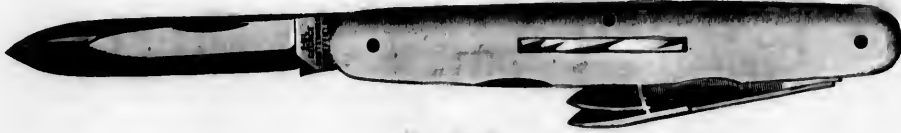

No. 54758

No. 54758—3½ inch, Pearl Handle, 4 Blades, Brass Lined.....per doz. \$35.75

oz. \$10.00
22.45



No. 55920

No. 55920—4 inch, German Silver Handle.....per doz. 33.80

oz. 21.15



No. 55934

No. 55934—3½ inch, Stag Handle, 2 Blades, Fleam, Hoof Hook, Cork Screw and Reamer.....per doz. 20.15

z. 21.15
30.55

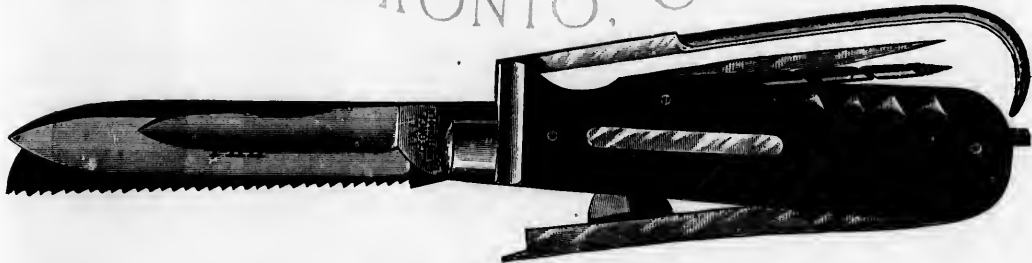

No. 55944

No. 55944—3½ inch, Stag Handle, 2 Blades, Saw, Fleam, Hoof Hook, Cork Screw, Gimlet, Reamer, Tweezers and Picker.....per doz. 34.50

14.00
14.05
21.45

20.80
28.00

WOSTENHOLM'S POCKET KNIVES

ONE-BLADE POCKET KNIVES

Full size cuts.



Nos.	51080	51062	51032	51042	51182	51692		
No.	51080-3 1/2	51062-3 1/2	51032-3 1/2	51042-3 1/2	51182-3 1/2	51692-4 1/2	inch, Iron Handle, 1 Blade	per doz.
"	51062-3 1/2	"	"	"	"	"	Buff " 1 " Brass Lined, German Silver Bolster	\$3.00
"	51022-3 1/2	"	"	"	"	"	" " 1 " Iron Lined and Bolster (pattern as No. 51032)	5.35
"	51022-3 1/2	"	"	"	"	"	" " 1 " Iron Lined and Bolster (pattern as No. 51032)	4.55
"	51032-3 1/2	"	"	"	"	"	" " 1 " White Bone Handle, 1 Blade, Iron Lined and Bolster (pattern as No. 51032)	4.55
"	51032-3 1/2	"	"	"	"	"	" " 1 " Buff " " " " " " " "	5.05
"	51035-3 1/2	"	"	"	"	"	" " 1 " White Bone " " " " " " " "	5.05
"	51042-3 1/2	"	"	"	"	"	" " 1 " Buff " " " " " " " "	5.85
"	51182-3 1/2	"	"	"	"	"	" " 1 " " " " " " " " "	6.00
"	51692-4 1/2	"	"	"	"	"	" " 1 " " " " " " " " " German Silver Bolster	8.50

WOSTENHOLM'S POCKET KNIVES

ONE-BLADE

Full size cuts.

TWO-BLADE



No.	Size	Handle	Blade	Price
Nos. 51123				
No. 51123	3 1/2 inch	Grey Buff	1 Blade, Iron Lined and Bolster	per doz. \$5.35
" 51133	3 1/2 "	"	"	5.85
" 51143	3 1/2 "	"	"	6.50
" 52082	3 1/2 "	Buff	2 " Brass Lined, G. S. Bolster (pattern as No. 52062)	7.45
" 52072	3 1/2 "	"	"	8.30
" 52082	3 1/2 "	"	"	9.00
" 52233	3 1/2 "	Grey Buff	"	12.05
" 52022	3 1/2 "	Buff	2 " Iron Lined and Bolster (pattern as No. 52042)	6.85
" 52025	3 1/2 "	White Bone	"	6.85
" 52032	3 1/2 "	Buff	"	7.45
" 52035	3 1/2 "	White Bone	"	7.45
" 52042	3 1/2 "	Buff	"	8.50
" 52045	3 1/2 "	White Bone	"	8.50

WOSTENHOLM'S POCKET KNIVES

Full size cuts.

TWO-BLADE POCKET KNIVES



Nos. 52692

52172

52182

52133

52143

52152

No. 52692	4 1/2	Inch, Buff Handle,	2	Blades, Iron Lined, German Silver Bolster	per doz.	\$11.20
" 52694	4 1/2	" Stag "	"	" " " "	"	12.50
" 52172	3 1/2	" Buff "	"	" " " "	"	9.10
" 52182	3 1/2	" " "	"	" " and Bolster	"	9.75
" 52133	3 1/2	" Grey Buff "	"	" " " "	"	8.05
" 52143	4 1/2	" " "	"	" " " "	"	9.45
" 52152	4	" Buff "	2	Brass Lined, German Silver Bolsters	"	9.75

JOSEPH RODGERS & SON'S

TRADE (❖❖) MARK

POCKET CUTLERY

Full size cuts.



No. 10129

No. 10127-2½ inch, Ivory Handle, 1 Blade, Brass Lined, German Silver Bolster	per doz.	\$6.45
“ 10129-2½ “ Shell “ 1 “ “ “	“	10.50



No. 20207

No. 20217

No. 20207-2½ inch, Ivory Handle, 2 Blades, Brass Lined, German Silver Bolsters	per doz.	11.65
“ 20217-2½ “ Ivory “ 2 “ “ “ “	“	11.65
“ 20218-2½ “ Pearl “ 2 “ “ “ “	“	15.55

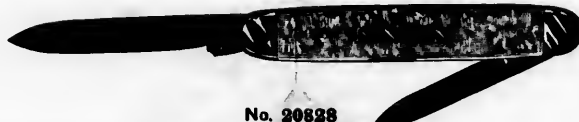

No. 20828

No. 20828-2½ inch, Pearl Handle, 2 Blades, Brass Lined, German Silver Bolster	per doz.	20.25
“ 20838-3 “ “ “ 2 “ “ “ “	“	22.95
“ 20912-3½ “ Buff “ 2 “ without Name Plate (pattern as No. 20828)	“	21.00



No. 20237

No. 20237-3 inch, Ivory Handle, 2 Blades, Brass Lined	per doz.	8.75
“ 20238-3 “ Pearl “ 2 “ “ “	“	12.85

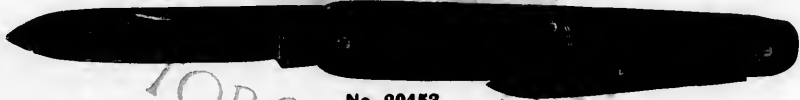

No. 20453

No. 20433-2½ inch, Buff Handle, 2 Blades, Brass Lined	per doz.	7.00
“ 20437-2½ “ Ivory “ 2 “ “ “	“	7.00
“ 20438-2½ “ Pearl “ 2 “ “ “	“	12.05
“ 20443-3 “ Buff “ 2 “ “ “	“	7.40
“ 20443½-3 “ “ “ “ “ with Nail Blade (pattern as No. 20443)	“	7.40
“ 20444-3 “ Stag “ 2 Blades, Brass Lined	“	7.40
“ 20447-3 “ Ivory “ 2 “ “ “	“	7.40
“ 20447½-3 “ “ “ “ “ with Nail Blade (pattern as No. 20447)	“	7.40
“ 20448-3 “ Pearl “ 2 Blades, Brass Lined	“	12.45
“ 20448½-3 “ “ “ “ “ with Nail Blade (pattern as No. 20448)	“	12.45
“ 20451-3½ “ Cocoa “ 2 Blades, Brass Lined	“	7.00
“ 20453-3½ “ Buff “ 2 “ “ “	“	7.00
“ 20454-3½ “ Stag “ 2 Blades, Brass Lined	“	7.00
“ 20457-3½ “ Ivory “ 2 “ “ “	“	7.00
“ 20457½-3½ “ “ “ “ “ with Nail Blade (pattern as No. 20457)	“	7.00
“ 20458-3½ “ Pearl “ 2 Blades, Brass Lined	“	12.85
“ 20459-3½ “ “ “ “ “ with Nail Blade (pattern as No. 20458½)	“	12.85
“ 20463-3½ “ Buff “ 2 Blades, Brass Lined	“	8.75
“ 20464-3½ “ Stag “ 2 “ “ “	“	8.75
“ 20467-3½ “ Ivory “ 2 “ “ “	“	8.75
“ 20468-3½ “ Pearl “ 2 “ “ “	“	17.15



\$11.20
12.50
9.10
9.75
8.65
9.45
9.75

RODGERS' POCKET KNIVES

Full size cuts.



No. 20497

No. 20493-3	inch, Buff Handle, 2 Blades, Brass Lined, German Silver Bolsters	per doz.	\$12.85
" 20494-3	" Stag " 2 " " " " " " " " " " " "	"	12.85
" 20497-3	" Ivory " 2 " " " " " " " " " " " "	"	12.85

No. 20



No. 20668

No. 20668-3	inch, Pearl Handle, 2 Blades, Brass Lined, German Silver Bolsters	per doz.	16.35
" 20671-3	" Cocoa " 2 " " " " " " " " " " " "	"	12.85
" 20673-3	" Buff " 2 " " " " " " " " " " " "	"	12.85

No. 20
" 20
" 20

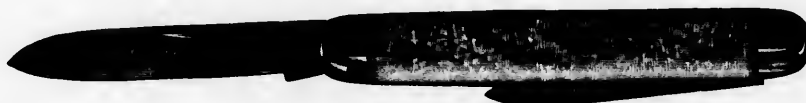

No. 20658

No. 20658-3	inch, Pearl Handle, 2 Blades, Brass Lined, German Silver Bolsters	per doz.	17.50
-------------	---	----------	-------

No. 20
" 20



No. 20597

No. 20597-3	inch, Ivory Handle, German Silver Bolsters	per doz.	25.70
-------------	--	----------	-------

No. 20



No. 20418

No. 20408-2	inch, Pearl Handle, 2 Blades, Brass Lined, German Silver Bolsters	per doz.	23.35
" 20412-3	" Buff " 2 " " " " " " " " " " " "	"	17.50
" 20417-3	" Ivory " 2 " " " " " " " " " " " "	"	19.45
" 20418-3	" Pearl " 2 " " " " " " " " " " " "	"	24.50
" 20419-3	" Shell " 2 " " " " " " " " " " " "	"	23.35
" 20428-3	" Ivory " 2 " " " " " " " " " " " "	"	25.70
" 20448-3	" Pearl " 2 " " " " " " " " " " " "	"	25.70

No. 20
" 20



No. 20537

No. 20537-3	inch, Ivory Handle, 2 Blades, Brass Lined, German Silver Bolsters	per doz.	22.00
-------------	---	----------	-------

No. 20
" 20

RODGERS' POCKET KNIVES

THREE-BLADE PENKNIVES

Full size cuts.



No. 33464. Cut of 3 1/4 inch.

No. 33463	— 3 1/4 inch, Buff Handle, 3 Blades, Brass Lined	per doz.	\$11.70
" 33464	— 3 1/4 " Stag " 3 " "	"	11.70
" 33467	— 3 1/4 " Ivory " 3 " "	"	11.70



No. 33494

No. 33494	— 3 1/4 inch, Stag Handle, 3 Blades, Brass Lined, German Silver Bolsters	per doz.	15.75
-----------	--	----------	-------



No. 33583

No. 33583	— 3 1/4 inch, Buff Handle, 3 Blades, Brass Lined, German Silver Bolsters	per doz.	17.50
" 33584	— 3 1/4 " Stag " 3 " " " " "	"	17.50
" 33587	— 3 1/4 " Ivory " 3 " " " " "	"	17.50



No. 33698

No. 33698	— 2 inch, Pearl Handle, 3 Blades, Brass Lined, German Silver Bolsters	per doz.	17.50
" 33698	— 2 1/2 " " " 3 " " " " "	"	17.50



No. 33318

No. 33298	— 2 1/2 inch, Pearl Handle, 3 Blades, Brass Lined, German Silver Bolsters	per doz.	28.80
" 33318	— 3 1/4 " " " 3 " " " " "	"	35.00
" 33907	— 3 1/4 " Ivory Handle, 3 " " " " " without Name Plate	"	20.15

RODGERS' POCKET KNIVES



No. 11892. Three-quarters size cut.

No. 11892— $\frac{3}{4}$ inch, Buff Handle, 1 Blade, Iron Lined, Drilled..... per doz. \$8.95

TWO-BLADE POCKET KNIVES



No. 22572. Three-quarter size cut.

No. 22572— $\frac{3}{4}$ inch, Buff Handle, 2 Blades, Brass Lined, German Silver Bolster per doz. 10.90
 " 22575— $\frac{3}{4}$ " White Bone Handle, 2 Blades, Brass Lined, German Silver Bolster..... " 10.90
 " 22581— $\frac{1}{2}$ " Cocoa " 2 " " " " " " " " 11.10
 " 22582— $\frac{1}{2}$ " Buff " 2 " " " " " " " " 11.70

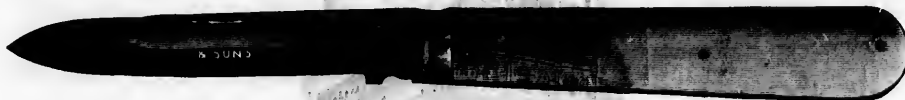

No. 22935. Full size cut.

No. 22922—3 inch, Buff Handle, 2 Blades, Iron Lined and Bolster per doz. 7.40
 " 22925—3 " White Bone Handle, 2 Blades, Iron Lined and Bolster..... " 7.40
 " 22932— $\frac{3}{4}$ " Buff " 2 " " " " " " " " 7.60
 " 22935— $\frac{3}{4}$ " White Bone " 2 " " " " " " " " 7.60
 " 22942— $\frac{3}{4}$ " Buff " 2 " " " " " " " " 8.20
 " 22945— $\frac{3}{4}$ " White Bone " 2 " " " " " " " " 8.20



No. 22754. Full size cut.

No. 22712—2 $\frac{3}{4}$ inch, Buff Handle, 2 Blades, Iron Lined and Bolster per doz. 6.45
 " 22715—2 $\frac{3}{4}$ " White Bone Handle, 2 Blades, Iron Lined and Bolster..... " 6.45
 " 22722—3 " Buff " 2 " " " " " " " " 7.00
 " 22725—3 " White Bone " 2 " " " " " " " " 7.00
 " 22731— $\frac{3}{4}$ " Cocoa " 2 " " " " " " " " 7.80
 " 22732— $\frac{3}{4}$ " Buff " 2 " " " " " " " " 7.80
 " 22735— $\frac{3}{4}$ " White Bone " 2 " " " " " " " " 7.80
 " 22741— $\frac{3}{4}$ " Cocoa " 2 " " " " " " " " 8.55
 " 22742— $\frac{3}{4}$ " Buff " 2 " " " " " " " " 8.55
 " 22744— $\frac{3}{4}$ " Stag " 2 " " " " " " " " 8.55
 " 22745— $\frac{3}{4}$ " White Bone " 2 " " " " " " " " 8.55
 " 22752— $\frac{3}{4}$ " Buff " 2 " " " " " " " " 9.55
 " 22754— $\frac{3}{4}$ " Stag " 2 " " " " " " " " 9.55
 " 22762— $\frac{1}{2}$ " Buff " 2 " " " " " " " " 10.90
 " 22765— $\frac{1}{2}$ " White Bone " 2 " " " " " " " " 10.90

EDWARDS SONS & CO'S POCKET OUTLERY

Full size cuts.



No. 6128

No. 6125	—White Bone Handle, 1 Blade, Brass Lined, German Silver Bolster	per doz.	\$1.80
" 6128	—Pearl " " " " " " " " " "	" "	3.70



No. 6607



No. 6208

No. 6607	—Ivory Handle, 2 Blades, Brass Lined, German Silver Bolsters	per doz.	2.40
" 6608	—Pearl " " as No. 6607	" "	3.50
" 6208	— " " 2 Blades, Brass Lined	" "	3.75



No. 6218

No. 6218	—Pearl Handle, 2 Blades, Brass Lined, German Silver Bolsters	per doz.	3.00
----------	--	----------	------

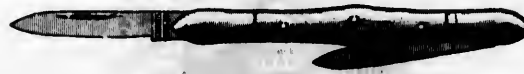

No. 6576

No. 6576	—White Bone Handle, 2 Blades, Brass Lined, German Silver Bolsters	per doz.	2.45
" 6578	—Pearl " " " " " " " " " "	" "	2.85



No. 6228

No. 6228	—Pearl Handle, 2 Blades, Brass Lined, German Silver Bolsters	per doz.	3.00
----------	--	----------	------

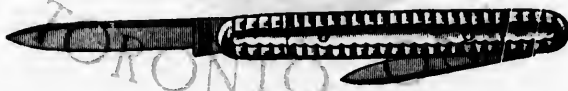

No. 6248

No. 6248	—Pearl Handle, 2 Blades, Brass Lined and Bolsters	per doz.	3.00
----------	---	----------	------



No. 6258

No. 6258	—Pearl Handle, 2 Blades, Brass Lined and Bolsters	per doz.	4.30
----------	---	----------	------



No. 6616

No. 6616	—Ivory Celluloid Handle, 2 Blades, Brass Lined, German Silver Bolsters	per doz.	2.00
----------	--	----------	------

EDWARDS' POCKET KNIVES

Full size cuts.



No. 6625

No. 6625—White Bone Handle, 2 Blades, Brass Lined per doz. 2.75



No. 6268

No. 6268—Pearl Handle, 2 Blades, Brass Lined, German Silver Bolsters per doz. 3.25



No. 6638

No. 6638—Pearl Handle, 2 Blades, Brass Lined, German Silver Bolsters per doz. 4.70



No. 6435

No. 6433—Grey Buff Handle, 2 Blades, Brass Lined per doz. 2.90
 " 6435—White Bone " 2 " " " 2.60



No. 6798

No. 6798—Pearl Handle, 2 Blades, Brass Lined, German Silver Bolsters per doz. 4.20



No. 6826

No. 6826—Ivory Celluloid Handle, 2 Blades, Brass Lined, German Silver Bolsters per doz. 3.10
 " 6828—Pearl " 2 " " " 3.50



No. 6276

No. 6276—Ivory Celluloid Handle, 2 Blades, Brass Lined, German Silver Edges per doz. 2.65

EDWARDS' POCKET KNIVES

Full size cuts.



No. 6308

No. 6308—Pearl Handle, 2 Blades, Brass Lined, German Silver Bolsters per doz. \$4.70



No. 6533

No. 6533—Grey Buff Handle, 2 Blades, Brass Lined, German Silver Bolsters per doz. 4.50
 " 6535—White Bone " 2 " " " " " " 4.30



No. 6538

No. 6538—Pearl Handle, 2 Blades, Brass Lined, German Silver Bolsters..... per doz. 6.20



No. 6675

No. 6675—White Bone Handle, 2 Blades, Brass Lined, German Silver Bolsters..... per doz. 3.80

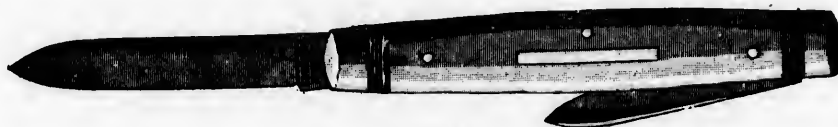

No. 6745

No. 6745—White Bone Handle, 2 Blades, Brass Lined, German Silver Bolsters per doz. 4.20



No. 6853

No. 6853—Grey Buff Handle, 2 Blades, Brass Lined, German Silver Bolsters.... per doz. 4.40
 " 6855—White Bone " 2 " " " " " " 4.20

EDWARDS' POCKET KNIVES

Full size cuts.

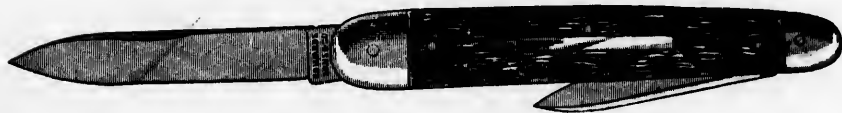

No. 6874

No. 6874—Stag Handle, 2 Blades, Brass Lined, German Silver Bolsters per doz. \$4.60



No. 7853

No. 7853—Grey Buff Handle, 2 Blades, Brass Lined, German Silver Bolsters per doz. 4.40



No. 6733

No. 6733—Grey Buff Handle, 2 Blades, Brass Lined, German Silver Bolsters per doz. 4.70
" 6735—White Bone " 2 " " " " " " 4.00



No. 6874

No. 6873—Grey Buff Handle, 2 Blades, Brass Lined, German Silver Bolsters per doz. 5.00
" 6874—Stag " 2 " " " " " " 5.00

THREE-BLADE PENKNIVES

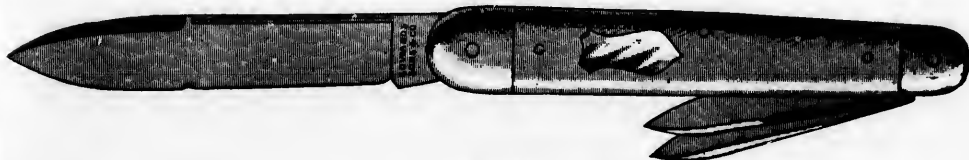

No. 63735

No. 63735—White Bone Handle, 3 Blades, Brass Lined, German Silver Bolsters per doz. 5.40

EDWARDS' POCKET KNIVES

Full size cuts.



No. 63873

No. 63873—Grey Buff Handle, 3 Blades, Brass Lined, German Silver Bolsters per doz. 6.80



No. 63874

No. 63874—Stag Handle, 3 Blades, Brass Lined, German Silver Bolsters per doz. 6.60

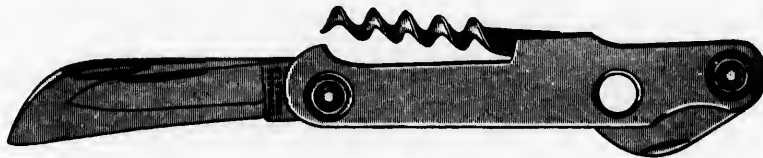

No. 65500

No. 65500—German Silver Handle, 2 Blades, Wire Cutter and Cork Screw..... per doz. 6.60



No. 65518

No. 65518—Pearl Handle, 2 Blades and Scissors, Brass Lined..... per doz. 11.00

EDWARDS' POCKET KNIVES

Full size cuts.



No. 61570

No. 61570—Nickel Metal Handle, 1 Blade, Iron Lined per doz. \$0.75
 " 61572—Black Wood Checkered Handle, 1 Blade, Iron Lined " 0.72



No. 61512

No. 61512—Black Wood Handle, 1 Blade, Iron Lined and Bolster per doz. 1.45



No. 61522

No. 61522—Black Wood Handle, 1 Blade, Iron Lined and Bolster per doz. 1.70



No. 61001

No. 61001—Brown Wood Handle, 1 Blade, Iron Lined and Bolster per doz. 1.30

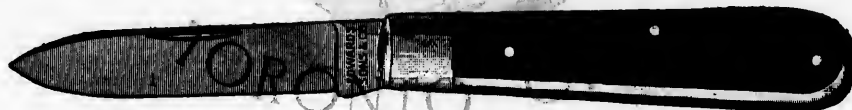

No. 61012

No. 61011—Rosewood Handle, 1 Blade, Iron Lined and Bolster per doz. 1.45
 " 61012—Ebony " 1 " " " " 1.45



No. 61022

No. 61021—Rosewood Handle, 1 Blade, Iron Lined and Bolster per doz. 1.90
 " 61022—Ebony " 1 " " " " 1.90

EDWARDS' POCKET KNIVES

Full size cuts.



No. 61032

No. 61031—Rosewood Handle, 1 Blade, Iron Lined and Bolster per doz. \$2.25
 " 61032—Ebony " 1 " " " " 2.25



No. 61581

No. 61581—Rosewood Handle, 1 Blade, Iron Lined and Bolster per doz. 2.40

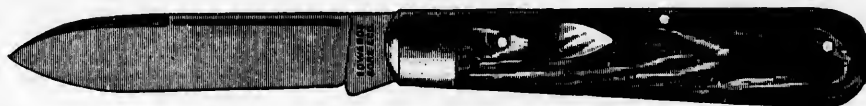

No. 61161

No. 61161—Cocoa Handle, 1 Blade, Brass Lined, German Silver Bolster per doz. 2.20



No. 61151

No. 61151—Rosewood Handle, 1 Blade, Brass Lined, German Silver Bolster per doz. 2.30

TWO-BLADE POCKET KNIVES



No. 62001

No. 62001—Brown Wood Handle, 2 Blades, Iron Lined and Bolster per doz. 1.90



No. 62012

No. 62012—Ebony Handle, 2 Blades, Iron Lined and Bolster per doz. 2.20

EDWARDS' POCKET KNIVES

Full size cuts.

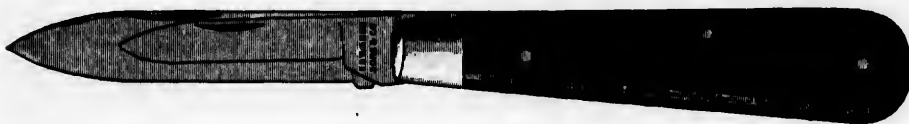

No. 62562

No. 62562—Ebony Handle, 2 Blades, Iron Lined and Bolster per doz. \$2.40

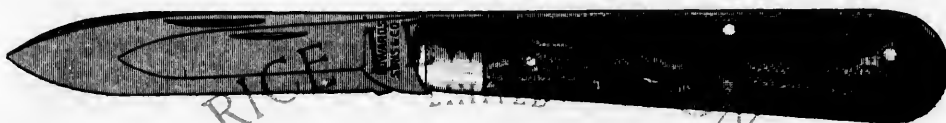

No. 62021

No. 62021—Rosewood Handle, 2 Blades, Iron Lined and Bolster per doz. 2.55
 " 61022—Ebony " 2 " " " " 2.55



No. 62542

No. 62542—Ebony Handle, 2 Blades, Iron Lined and Bolster per doz. 2.70

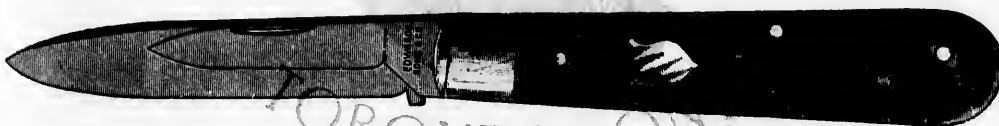

No. 62032

No. 62031—Rosewood Handle, 2 Blades, Iron Lined and Bolster per doz. 3.10
 " 62032—Ebony " 2 " " " " 3.10

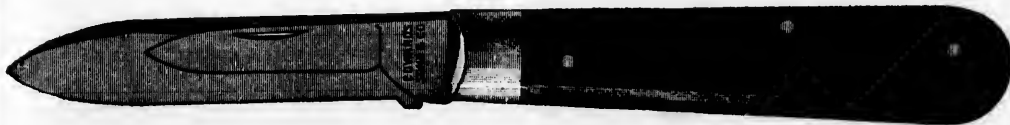

No. 62192

No. 62191—Rosewood Handle, 2 Blades, Iron Lined and Bolster per doz. 3.00
 " 62192—Ebony " 2 " " " " 3.00

EDWARDS' POCKET KNIVES

Full size cuts.



No. 62852

No. 62852—Ebony Handle, 2 Blades, Iron Lined and Bolsterper doz. \$3.55



No. 62151

No. 62151—Rosewood Handle, 2 Blades, Brass Lined, German Silver Bolsterper doz. 3.25

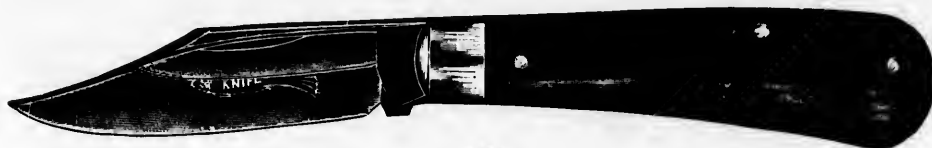

No. 62581

No. 62581—Rosewood Handle, 2 Blades, Iron Lined and Bolster.....per doz. 3.50

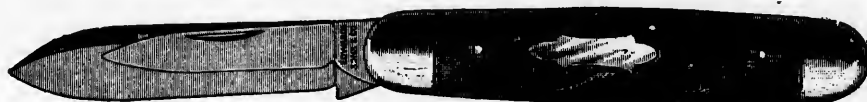

No. 62171

No. 62171—Rosewood Handle, 2 Blades, Brass Lined, German Silver Bolsters.....per doz. 4.70



No. 62181

No. 62181—Rosewood Handle, 2 Blades, Brass Lined, German Silver Bolsters.....per doz. 4.80

SHACKLE KNIVES



No. 91872



No. 91854

Two-Thirds size cuts.

TURNER'S SHACKLE KNIVES

- No. 91872—4½ inch, Buff Handle, 1 Blade, Iron Lined and Bolster..... per doz. \$0.10
 " 91854—4½ inch, Stag Handle, 1 Blade, Iron Lined and Bolster..... per doz. 8.75
 " 91864—4½ inch, Stag Handle, 1 Clip Blade, pattern as No. 91854..... per doz. 8.75

BOKER'S SHACKLE KNIVES

- No. 01602—4½ inch, Ebony Handle, 1 Blade, "King Cutter" Quality, Iron Lined and Bolster..... per doz. 9.85

WOSTENHOLM'S SHACKLE KNIVES

- No. 51772—4½ inch, Buff Handle, 1 Blade, Iron Lined and Bolster..... per doz. 8.00
 " 51774—4½ inch, Stag Handle, 1 Blade, Iron Lined and Bolster..... per doz. 9.30



No. 01602

Full size cuts.



No. 51772

RICHARD LEWIS LIMITED

TORONTO, CANADA

per doz. \$3.55

per doz. 3.25

per doz. 3.50

per doz. 4.70

per doz. 4.80

SPRING BACK KNIVES

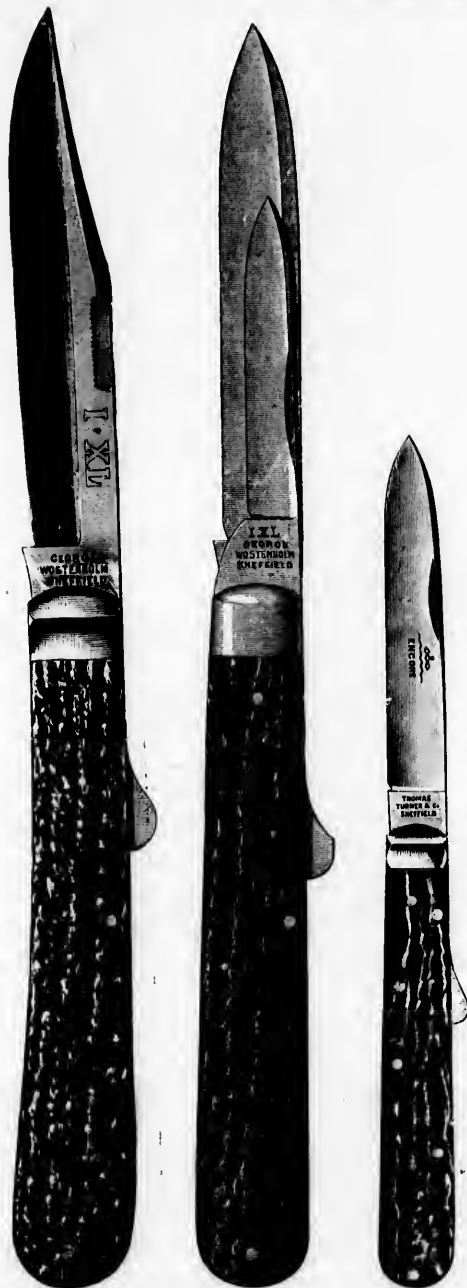

Nos. 51794

52804

91884

Full size cuts.

Two-thirds size cut of 4½ inch.

TURNER'S SPRING BACK KNIVES

ONE-BLADE

Stag Handle, Iron Lined and Bolster.

Length	4½	5½	6½ inch.
No. 91884per doz.	\$0.45	14.15.	18.50

No.

WOSTENHOLM'S SPRING BACK KNIVES

ONE-BLADE

No. 51784 —5 inch, Stag Handle, 1 Spear Blade, Iron Lined and Bolster, pattern as No. 52804.....per doz.	\$12.50
" 51794 —4½ inch, Stag Handle, 1 Clip Blade, Iron Lined and Bolster...per doz.	10.75

No.

TWO-BLADE

No. 52804 —4½ inch, Stag Handle, 2 Blades, Iron Lined and Bolster.....per doz.	15.00
--	-------

No.

BOKER'S SPRING BACK KNIVES

Full size cuts.



No. 85674

No. 85674—5½ inch, Stag Handle, 1 Blade, "King Cutter" quality, Spring Back, Brass Lined, German Silver Flush Bolster..... per doz. \$17.75



No. 85664

No. 85664—5½ inch, Stag Handle, 1 Blade, "King Cutter" quality, Spring Back, Brass Lined, German Silver Cross Bolster..... per doz. 19.10

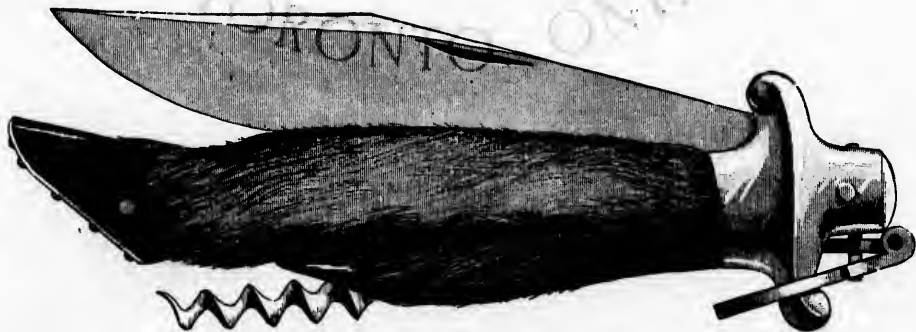

No. 85654

No. 85654—5½ inch, Deer Foot Handle, 1 Blade, Spring Back and Cork Screw, Brass Lined, German Silver Bolster..... per doz. 35.70

TURNER'S SHEATH KNIVES



No. 962

- No. 962**—Ebony Handle, Brass Rivets, 6 inch Blade, with Leather Sheath per doz. \$8.75
 " **981**—Rosewood Handle, 3 Large Brass Rivets, 6 inch Blade (Blade same pattern as No. 972), with
 Leather Sheath per doz. 0.05



No. 972

- No. 972**—Ebony Handle, Brass Rivets, 6 inch Blade, with Leather Sheath per doz. 0.35



No. 984

- No. 984**—Stag Handle, 6 inch Blade, with Leather Sheath per doz. 21.00



Style of Sheath for above Knives, Blocked to receive the Handle.

TURNER'S HUNTING KNIVES AND DAGGERS



No. 952



Blade for No. 952, full length 8½ inches.

Sheath for No. 952, full length 7½ inches.

No. 952—Turner's Triplicate Hunting Knife, Scored Ebony Handle, Full Length 11 inches, with Small Blade, Cork Screw, Turn Screw, Picker and Tweezers, supplied with 2 extra large Blades in case of breakage.....each \$13.50

DAGGERS



No. 934

No. 934—Stag Handle, 6 inch Blade, with Leather Sheath.....per doz. 14.00



No. 904

Length of Blade.....	5	6	7	8	inch.
" Handle.....	4½	4½	4½	4½	"
No. 904—Stag Handle (full), with Leather Sheath	\$14.00	15.00	17.50	21.00	per doz.

TURNER'S DAGGERS

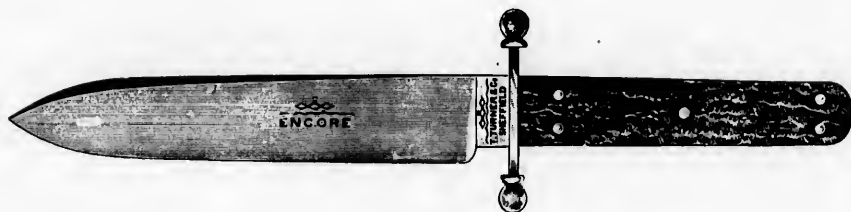

No. 914

Length of Blade	5	6	7	8	inch.
" Handle	4½	4¾	4¾	4½	"
No. 914—Stag Handle, with Leather Sheath..... per doz.	\$14.75	16.25	19.00	22.50	

No. 924

With Clip Blade, pattern same as No. 914.

Length of Blade	5	6	7	8	inch.
" Handle	4½	4¾	4¾	4½	"
No. 924—Stag Handle, with Leather Sheath..... per doz.	\$14.75	16.25	19.00	22.50	



No. 944

Length of Blade.....	8	7	8	inch.
" Handle.....	4¾	4¾	4¾	"
No. 944—Stag Handle (full), with Leather Sheath..... per doz.	\$18.25	20.00	25.00	



Style of Sheath with Knives Nos. 904, 914, 934 and 944.

BUDDING AND PRUNING KNIVES

8 inch.
4½ " " " " " "
22.50

8 inch.
4½ " " " " " "
22.50

8 inch.
4½ " " " " " "
25.00



Nos. 91832

51842

91804

91814

91821

51824

Two-thirds size cut. Full size cut.

Two-thirds size cuts.

Full size cut.

No. 91832	—Turner's Budding Knife,	4½ inch,	Buff Handle, Brass Lined.....	per doz.	\$13.50
" 51842	—Wostenholm's " "	4½ " "	" " " " " " " " " " " "	" "	8.50
" 91804	—Turner's Pruning Knife,	3½ " "	Stag " " " " " " " " " "	" "	5.50
" 91814	— " " " "	4 " "	" " " " " " " " " "	" "	7.50
" 91821	— " " " "	4½ " "	Beech " " " " " " " " " "	" "	8.50
" 51824	—Wostenholm's " "	4½ " "	Stag " " " " " " " " " "	" "	12.95

FLEAMES AND FARRIERS' KNIVES



No. 35023
Full size cut.



No. 534
Two-thirds size cut.



No. 224. Full size cut.

RODGERS' HORSE FLEAMS

THREE-BLADE

No. 35000—3½ in., Brass Handle.....	per doz.	\$ 7.00
" 35023—3½ " Buff " Brass Lined, "		15.20

SEARCHERS

No. 224—Rodgers' Searchers, Buck Horn Handle.....	per doz.	\$6.00
" 524—Wostenholm's " " "	"	5.10
" 824—Grady & Co.'s " " "	"	4.50

FARRIERS' KNIVES

No. 234—Rodgers' Farriers' Knives, Buck Horn Handles, Blades assorted ½ to ¾ inch wide	per doz.	\$6.00
" 534—Wostenholm's " " " " ½ and ¾ " "	"	5.10
" 834—Grady & Co.'s " " " " ½ " " "	"	4.50

Len
No.
Len
No.
No.
"
"
No.
"
"
No.

POCKET KNIFE PURSES

GREY CHAMOIS

Length.....	2¾	3¾	3½	4	4¼ inch.
No. 7891—With Nickel-Plated Clasp..... per doz.	\$1.75	1.85	2.00	2.15	2.25

KID

Length.....	3¾	3½	4 inch.
No. 7853—With Nickel-Plated Clasp..... per doz.	\$2.05	2.05	2.05

ERASERS
With Sheaths.



No. 521

No. 521—Wostenholm's, 4 inch, Cocoa Handle..... per doz.	3.00
" 221—Rodger's 5 " " Pattern as No. 521..... "	5.25
" 232— " 5 " " " 521 with Metal Shoulder..... "	5.85

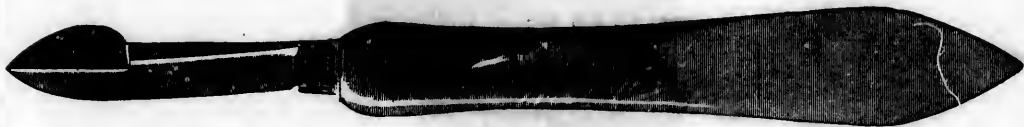

No. 541

No. 541—Wostenholm's, 4½ inch, Cocoa Handle..... per doz.	6.00
---	------



No. 532

No. 532—Wostenholm's, 4 inch, Ebony Handle..... per doz.	6.20
" 201—Rodger's 3¾ " Cocoa " Pattern as No. 532..... "	7.00
" 202— " 3¾ " Ebony " " " 532..... "	7.00

Full size cut
doz. \$6.00
5.10
4.50

NAIL NIPPERS

Full size cuts.

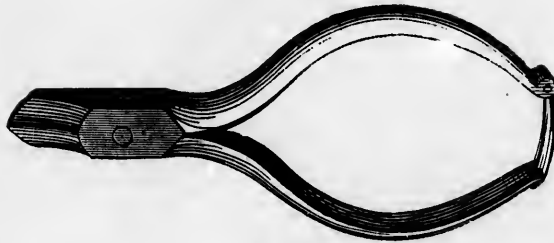

No. 353

No. 397—4 $\frac{1}{2}$ inch, Steel Polished, Pattern as No. 353.....	per doz.	\$ 5.00
" 353—3 $\frac{1}{2}$ " All Steel, Full Polished, extra quality.....	"	23.00
" 189—3 $\frac{1}{2}$ " Steel, Fancy Pattern, Nickel-Plated.....	"	28.00
" 150—4 " Polished, Angle Cutting.....	"	35.50

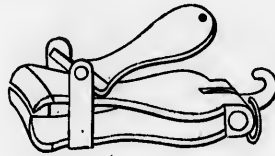

No. 7102



No. 2580

No. 7102—Steel, Nickel-Plated, Face Cutting.....	per doz.	5.05
" 3229— " " Side " length 2 $\frac{1}{4}$ inches.....	"	23.50
" 2580— " " Face "	"	8.50

NAIL FILES

Full size cuts.



No. 7520

No. 5520—Polished Steel, Length over all 3 $\frac{1}{4}$ inches.....	per doz.	5.20
" 7520— " " " 4 "	"	5.20
" 6520— " " " 4 " Knife as No. 4520.....	"	5.20
" 6893—Folding, 2 $\frac{1}{4}$ inch, German Silver Handle, 2 inch Nail Blade.....	"	9.00

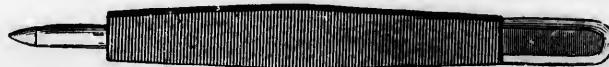

No. 1520

No. 1520—Polished Steel.....	per doz.	3.50
------------------------------	----------	------



No. 2520

No. 2520—Polished Steel, Length over all 4 inches.....	per doz.	3.50
--	----------	------

TWEEZERS



No. 508

No. 508—Polished Steel Tweezers and Ear Spoon, Length over all 2 inches..... per doz. \$2.95
 " 7453— " " " Nail File, " " 3 " " 3.35



No. 3521. Full size cut.

No. 3521—Polished Steel.....per doz. 5.20



No. 6555. Full size cut.

No. 6555—Polished Steel.....per doz. 7.40



No. 935. Full size cut.

No. 935—Polished Steel.....per doz. 13.85

WORK BOX SETS

On Cards. English Make.



Pattern Nos. 40 and 41 42 and 43 44 STILETTO

Four pieces, Button Hook, Tweezers, Nail File and Stiletto.

No. 40—Bone Handle, Length over all 3½ inches.....per doz. sets 10.80
 " 41—Pearl " " " 3½ " " 18.45
 " 42— " " " 4 " " 22.50
 " 43— " " " 4 " Extra Quality " 20.70
 " 44— " " " 4½ " " 34.20

WILLIAMS' SHAVING SOAP



No. 1—Barbers' Bar, 1 lb. packages, 6 cakes to the package per package \$0.70



No. 2



No. 3



No. 5

No. 2—Luxury Shaving Tablets, in round form to fit the cup	per doz.	5.00
" 3—Yankee Shaving Soap, in square cakes	"	2.40
" 4—Barbers' Favorite Soap,	"	1.00
" 5—Shaving Stick, in case (covered with Red Morocco Leatherette)	"	4.50

SHAVING BRUSHES



Nos. 100 and 105

No. 100—White Bristles, Black Enameled Wood Handles	per doz.	1.10
" 105— " " " "	"	1.40



No. 532

No. 532—White Bristles, Twine Bound, Brown Wood Handles	per doz.	3.00
---	----------	------

SHAVING BRUSHES



	Nos. 53	72	629	628	6937	
No.	53—White Bristle, Ebony Handle, Deep Nickel-Plated Ferrule	72—White Bristle, Nickel-Plated Handle	629—Badger Hair, Ebony Handle, Deep Nickel-Plated Ferrule	628—Badger Hair, Brown Wood Handle, Deep White Bone Ferrule	6937—All Badger Hair, Turned White Bone Handle with Grooved Collar	per doz.
						\$3.00
						3.50
						4.70
						3.60
						5.00
						18.00
						16.00

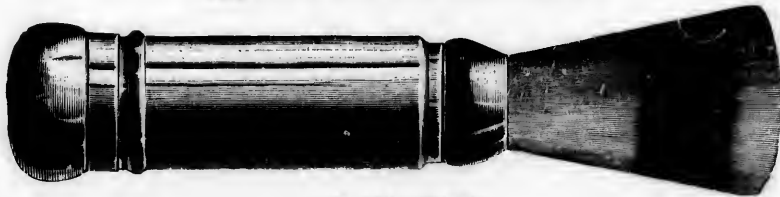

Nos. 625 and 535

No.	625—Badger Hair, Nickel-Plated Handle with Screw Cap	per doz.	6.40
	535—White Bristle, " " "	" "	3.60

Nos. 625 and 535 are Detachable, can be enclosed in Handle.

package \$0.70

per doz. 5.00
 " 2.40
 " 1.60
 " 4.50

per doz. 1.10
 " 1.40

doz. 3.00

RAZOR STROPS



No. 1

No. 1—Howard, 14 inch, Extra Heavy Fine Leather, with Fine Hone and Patent Handle.....per doz. \$8.50



No. 3

No. 3—Currier, 13½ inch, made from Heavy Leatherper doz. 5.70



No. 4

No. 4—Faultless, 13½ inch, Large Strop, made from Medium Grade Stockper doz. 4.30



No. 88

No. 88—Blue Label, 14 inch, Fine Four-Side Cushion Combination, with 1½ inch Nickel Ferruleper doz. 9.30



No. 255

No. 255—13 inch, Fine Double-Padded Cushion, with Extra Heavy Nickel Wire Frame.....per doz. 9.30



No. 210

No. 210—Phoenix, 11½ inch, three sides Leather and one side Hone.....per doz. 2.20

RAZOR STROPS

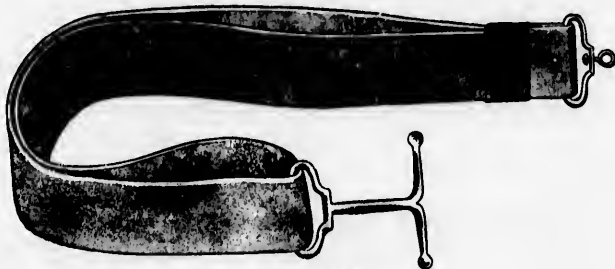

No. 448

No. 448—Double Swing, 17x2 in., Black Leather and Canvas, with Swivel per doz. \$6.30
 " 548— " 24½x2 " " and Black Enameled Handle. " 8.00



Nos. 171 and 174

No. 171—Double Swing, 17 x 2 inch, Oiled Leather and Canvas per doz. 5.50
 " 174— " 17 x 2 " White " " 5.50



Nos. 122 and 124

No. 122—Double Swing, 21 x 2 inch, White Leather and Canvas, with Swivel per doz. 6.00
 " 124— " 21 x 2 " Oiled " " 6.00

THE ORIGINAL HORSE-TAIL RAZOR STROPS



Nos. 1 to 2

No. 1 —15 x 1½ inch, with Nickered Eyelet per doz. 2.90
 " 1½—17 x 2 " " " " " 4.50
 " 2 —21 x 2 " " " " " 5.50



No. 3

No. 3—21 x 2 inch, with Swivel per doz. 7.00



No. 4

No. 4—17 x 2 inch, with Swivel per doz. 5.00

RAZOR STROPS

KAMPFE'S



No. 20

No. 20—New Improved Diagonal Star Safety Razor Strop, Leather per doz. \$18.00



No. 21

No. 21—New Improved Star Safety Razor Swing Strop, Canvas per doz. 10.00



No. 22

No. 22—New Improved Diagonal Razor Strop, adopted for the old style Razor, Leather..... per doz. 18.00

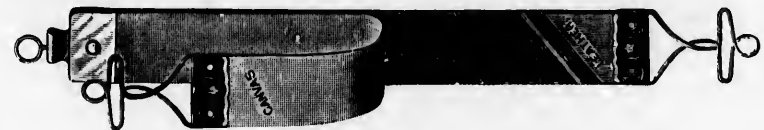

No. 23

No. 23—New Improved Diagonal Combination Razor Strop, for Barbers' use..... per doz. 36.00

SAFETY RAZOR STROPPING MACHINES

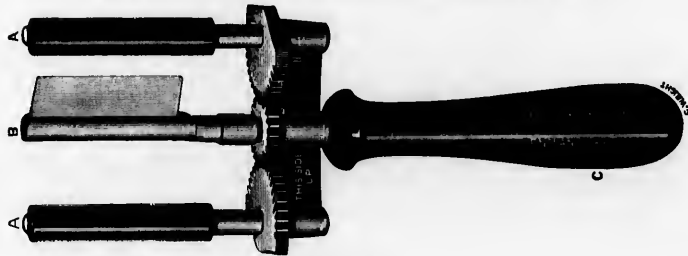

No. 30

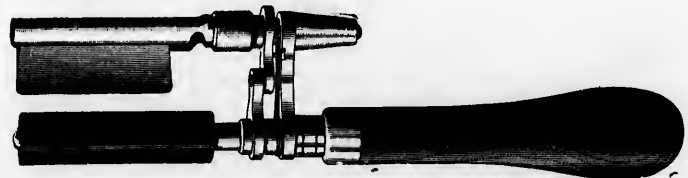

No. 31

No. 30—Double Roll Stropping Machines per doz. 48.00
 " 31—Single Roll " " " " " " " " 32.00

A Flexible Canvas or Leather Strop should be used with these Machines.

Star Sa
Extra S
Boker's

Gem Sa
Extra G
In
the blad
D
same an
frame a
strop as

No. 472

No. 372

STAR SAFETY RAZORS

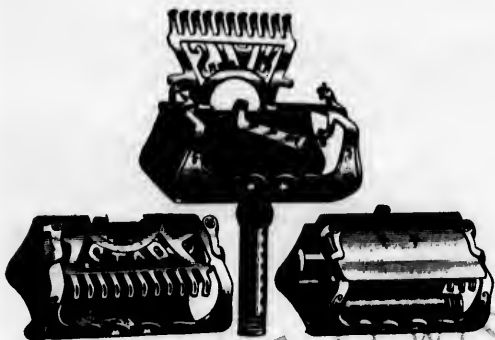

Star Safety Razors, in tin case per doz. \$33.50
 Extra Star Safety Razor Blades " 22.75
 Boker's extra Blades, suitable for either Star or Gem Safety Razors " 15.00

GEM SAFETY RAZORS



Gem Safety Razors, in tin case per doz. 33.50
 Extra Gem Safety Razor Blades " 22.75

In the Gem Safety Razors the frame or body can be cleaned during the process of shaving, without removing the blade.

DIRECTIONS.—For using the Star or Gem Safety Razors, lather the face well, apply the Safety Razor at the same angle as the old style of Razor, and draw it across the face with a firm stroke. After shaving, cleanse the frame and blade, wipe both thoroughly dry; take the blade, insert it in the holder provided for the purpose, and strop as usual; return the blade to the frame, keeping the star side up, and the instrument is ready for use.

CORN RAZORS



No. 472. Two-third size cut.

No. 472— $\frac{1}{2}$ inch wide, Ivory Handle per doz. \$10.50



No. 372. Full size cut.

No. 372— $\frac{3}{4}$ inch wide, Black Rubber Handle per doz. 8.30

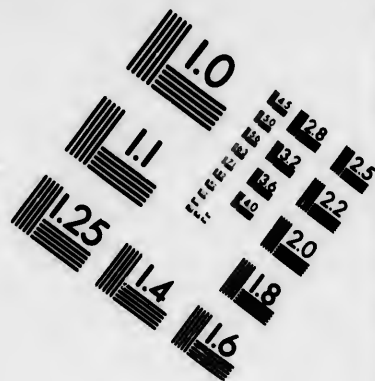
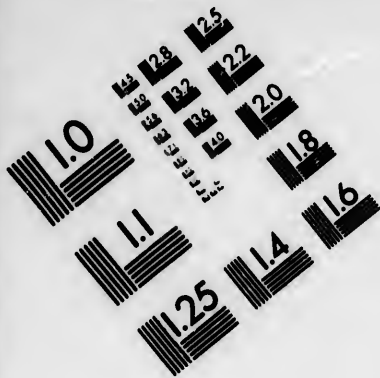

**IMAGE EVALUATION
TEST TARGET (MT-3)**

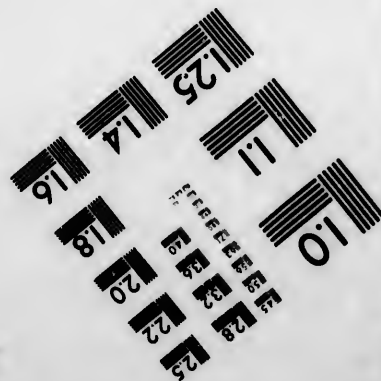
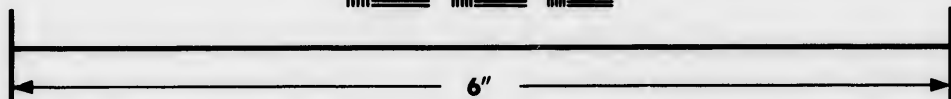
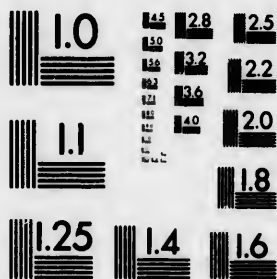

**Photographic
Sciences
Corporation**

23 WEST MAIN STREET
WEBSTER, N.Y. 14590
(716) 872-4503

14 28 25
12 22
10 20
8

01

HENRY BOKER & CO.'S



TREE BRAND BARBERS' SOISSORS

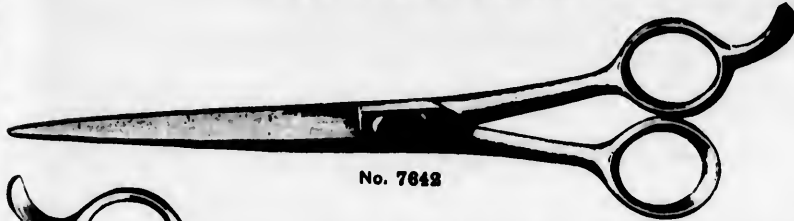

No. 7642

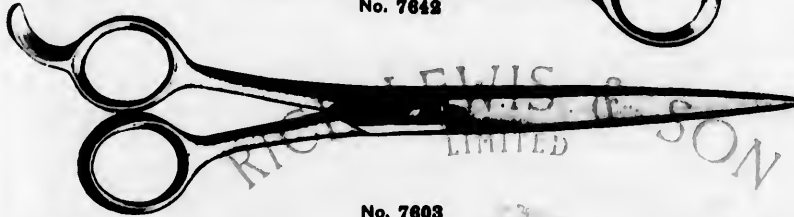

No. 7603

Length.....			8	inch.
No. 7642—Japanned Handle.....	per doz.	\$12.00		
" 7643—Nickel-Plated Handles.....	"	15.00		
" 7603—.....	with Patent Tension Screw which gives an even pressure to both blades in cutting.....	per doz.	16.00	

HENRY SEYMOUR CUTLERY CO'S. BARBERS' SOISSORS



Length.....	8	8½	9	inch.
Maroon Handles, Nickel-Plated Blades.....	per doz.	\$16.00	17.00	18.00

BOKER'S PAPER HANGERS' SHEARS

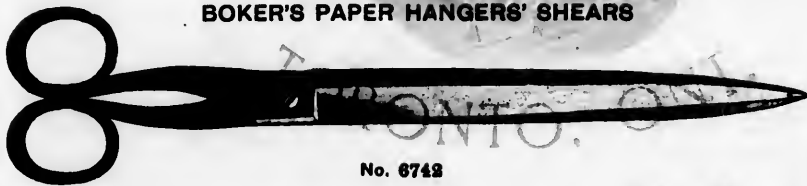

No. 6742

Length.....		10½	12	inch.
No. 6742—Japanned Handles, Steel Blades.....	per doz.	\$14.50	18.00	
" 6752—.....	" Fine Polished, Steel Blades	19.20	

SEYMOUR'S BANKERS' OR PAPER HANGERS' SHEARS



Length.....	12	14	inch.
Regular Light Pattern, Maroon Handles, Nickel-Plated Blades.....	per doz.	\$32.00	42.00

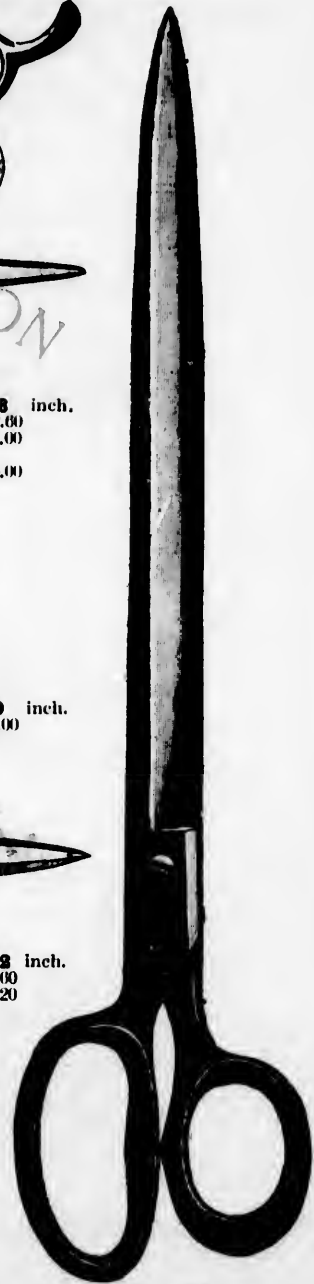

No. 6752

doz. \$22.70
22.70

7 Razors.

17.55
18.00
18.90

7 Razors.

3.40
4.40
4.75

doz. \$12.00
3.00

BOKER'S BANKERS' SHEARS

TREE BRAND

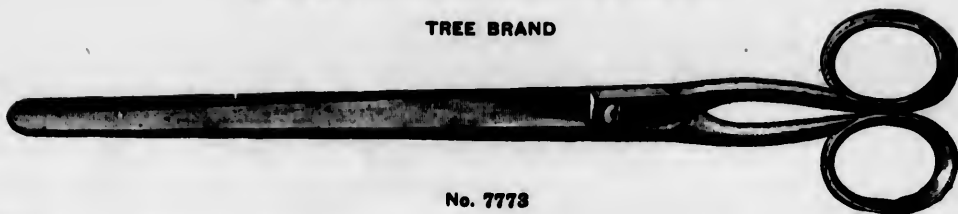

No. 7773

Length 9 inch.
 No. 7773—Light Pattern, Full Nickel Plated.....per doz. \$16.35

SEYMOUR'S SCISSORS AND TRIMMERS

TAILORS' POINTS



POCKET SCISSORS



Length 5 5½ 6 inch.
 Maroon Handles, Nickeled
 Bladesper doz. \$11.00 11.50 12.00

Length 4 4½ 5 inch.
 Maroon Handles, Nickeled
 Bladesper doz. \$10.00 10.50 11.00

STRAIGHT TRIMMERS

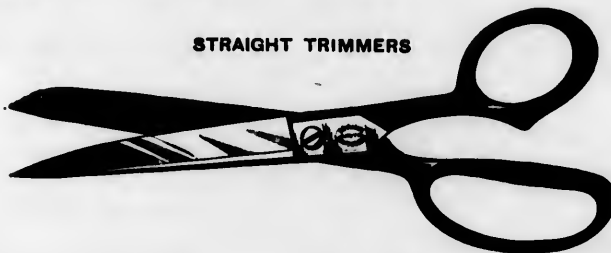

Length	6	6½	7	7½	8	8½	9	10	inch.
Seymour's Maroon Handle, Nickeled Blades..... per doz.	\$12.00	13.00	14.00	15.00	16.00	17.00	19.00	25.00	
" Full Nickel-Plated..... "	13.00	14.00	15.00	16.00	17.00	
115—Michigan Cutlery Co.'s Japanned Handle, N.P. Blade	13.00	14.00	15.00	16.00	17.00	19.00	
15—Michigan Cutlery Co.'s Full Nickel-Plated.. "	13.00	14.00	15.00	16.00	17.00	19.00	

BENT TRIMMERS

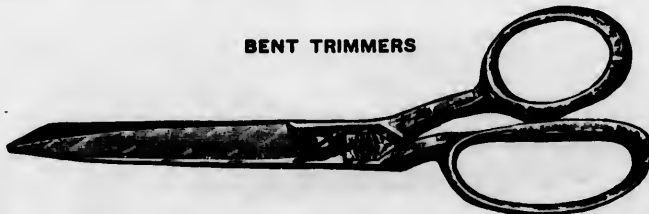

Length	8	9	10	11	12	13	inch
Seymour's Maroon Handle, Nickel-Plated Blade	\$17.00	22.00	27.00	30.00	33.00	36.00	

SEYMOUR'S TAILOR SHEARS

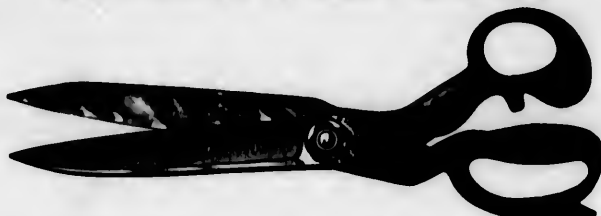

Nos.....	5	6	7	8	9	10
Full length.....	13	13½	14	14½	14½	15½ inch.
Japanese Handles, Nickel Blades..... per pair	\$8.00	9.00	10.00	11.00	12.00	13.00

SCISSORS

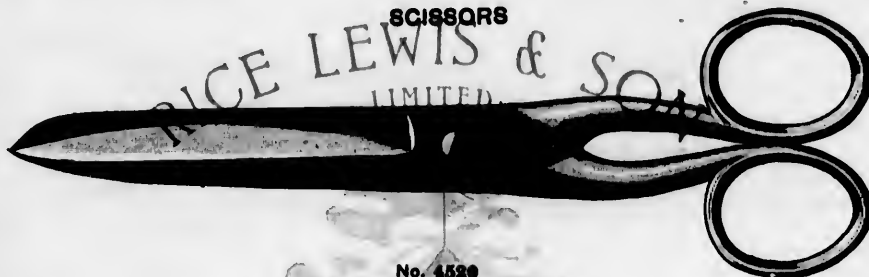

No. 4520

Length.....	5	6	7 inch.
No. 4520—Edward's, All Bright..... per doz.	\$2.10	2.70	3.55



No. 5573

Length.....	4½	5	5½	6	6½	7	7½	8 inch.
No. 5573—Edward's, All Bright..... per doz.	\$3.50	3.65	3.90	4.20	4.40	5.50	6.80	8.10

TORONTO, ONT.

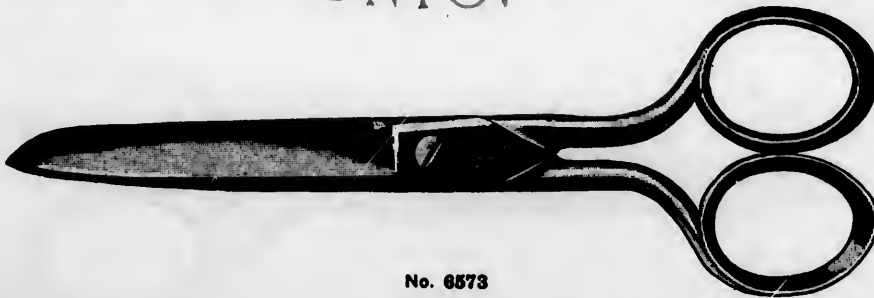

No. 6573

Length.....	4	4½	5	5½	6	6½	7 inch.
No. 6573—H. Boker & Co.'s, Full Nickel-Plated... per doz.	\$1.20	4.50	4.75	5.00	5.55	6.15	6.80

SCISSORS



No. 6514

Length..... 5 6 inch.
 No. 6514—H. Boker & Co.'s, Full Nickel-Plated..... per doz. \$5.10 6.15

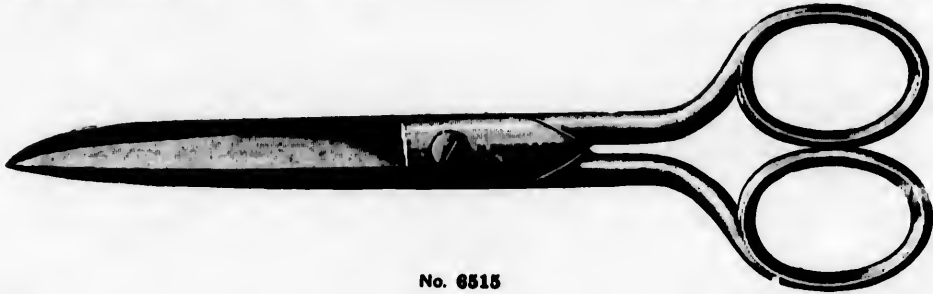

No. 6515

Length..... 4½ 5½ 6½ inch.
 No. 6515—H. Boker & Co.'s, Gilt Handles, Fine Polished Steel Blade... per doz. \$4.50 5.00 6.15



No. 6516

No. 6516—H. Boker & Co.'s, Fancy Gilt Handle, Fine Polished Steel Blade, Length 6 inches per doz. \$6.25

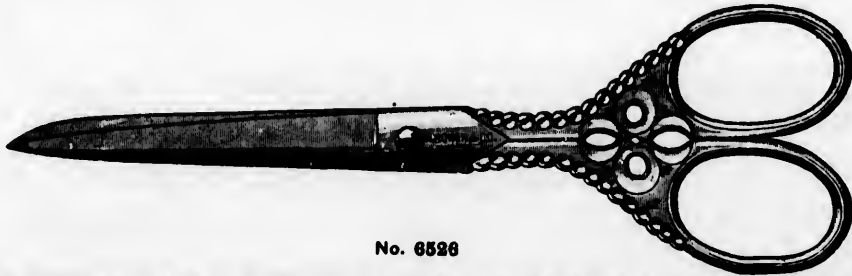

No. 6526

No. 6526—H. Boker & Co.'s, Fancy Gilt Handle, Fine Polished Steel Blades, Length 5 inches per doz. 5.00

Length
 No. 65

Length
 No. 65

Length
 No. 75

Length
 No. 85

SCISSORS

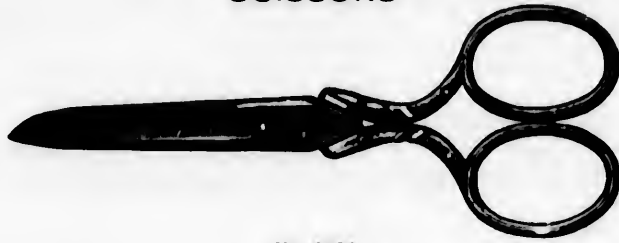

No. 6536

Length 4 inch.
 No. 6536—H. Boker & Co.'s, Fancy Gilt Handle, Fine Polished Steel Blade..... per doz. \$1.00



No. 6500

Length 4½ 5 5½ 6 6½ 7 inch.
 No. 6500—Turner & Co.'s, Full Polished per doz. \$1.20 1.10 5.10 0.25 7.10 8.15

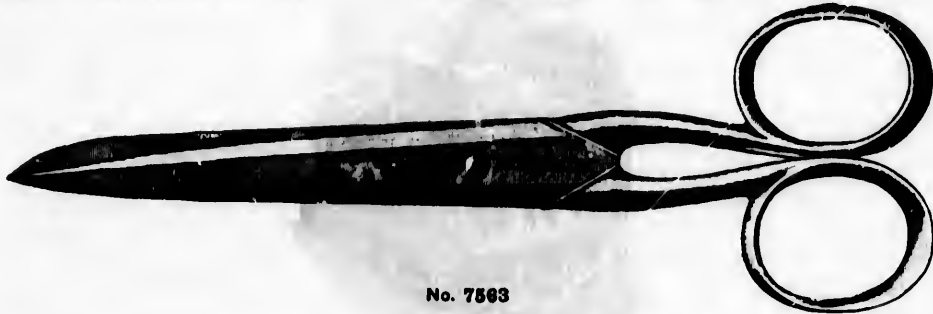

No. 7563

Length 4 4½ 5 5½ 6 6½ 7 inch.
 No. 7563—H. Boker & Co.'s, "Tree Brand," Full Nickel-Plated per doz. \$5.05 0.10 0.70 7.50 8.50 0.50 10.05



No. 8589

Length 4 4½ 5 5½ 6 6½ 7 inch.
 No. 8589—H. Boker & Co.'s "King Cutter," Finest Mirror Polished, Round Bows ... per doz. \$10.45 10.05 11.55 12.70 13.85 15.35 16.05

SCISSORS

SHEAR PATTERN

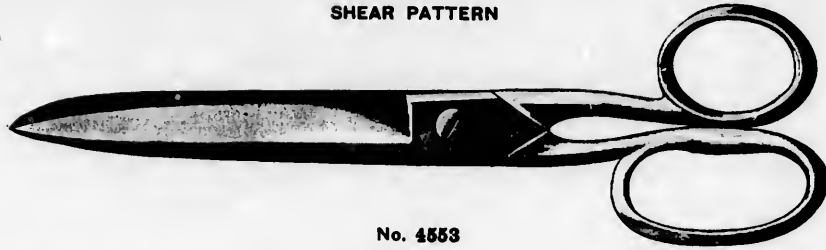

No. 4553

Length	6	7	8	inch.
No. 4553—Edwards', Shear Pattern, Full Nickel-Plated..... per doz.	\$4.50	5.40	6.80	

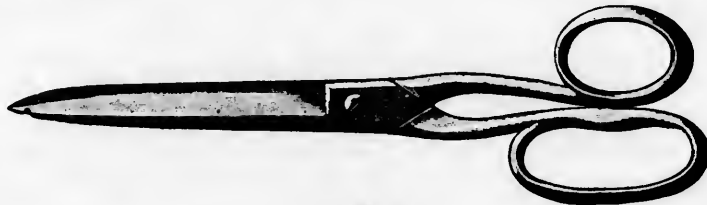

No. 6563

Length	6	7	8	inch.
No. 6563—H. Boker & Co.'s, Slim Shear Pattern, Full Nickel-Plated..... per doz.	\$6.25	8.05	9.85	



No. 6553

Length	7	8	9	inch.
No. 6553—H. Boker & Co.'s, Shear Pattern, Full Nickel-Plated..... per doz.	\$8.95	11.25	13.95	

LACE SCISSORS

Full size cuts.

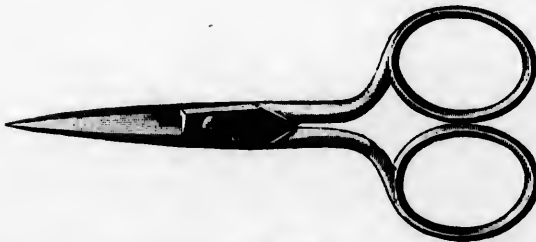

No. 4030

Length	3 1/4	inch.
No. 4030—Edwards', All Bright ... per doz.	\$1.65	

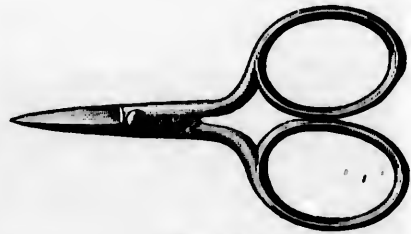

No. 4010

Length	2 1/2	3	inch.
No. 4010—H. Heuser's, All Bright..... per doz.	\$2.10	2.10	

Length
No. 501
" 602

Length
No. 601
" 604

Length
No. 603
" 607
" 601

Length
No. 601
" 606

LACE SCISSORS

Full size cuts.

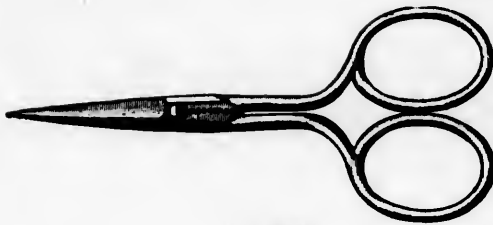

No. 7063

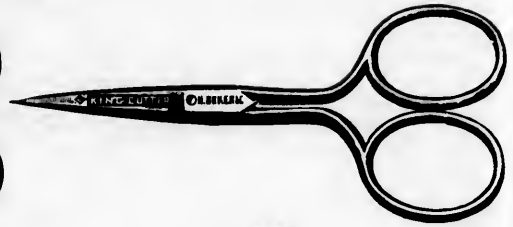

No. 8089

Length.....				3 1/4 inch.
No. 7063—H. Boker & Co.'s, "Tree Brand," Full Nickel-Plated	per doz.			\$5.55
" 8089— " " " " " " " " " " " "				9.75

Two-thirds size cuts.



No. 9010

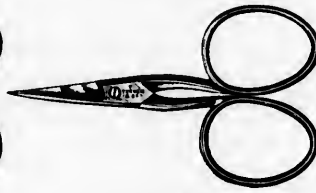

No. 9011

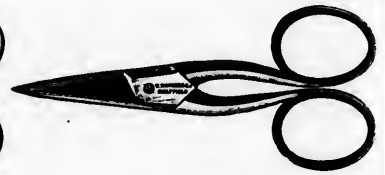

No. 9012

Length.....			3 1/4	3 1/2 inch.
No. 9010—Turner & Co.'s, Large Bows, Full Polished	per doz.			\$6.40
" 9011— " " " " " " " " " " " "			\$8.45	
" 9012— " " " " " " " " " " " "				6.40

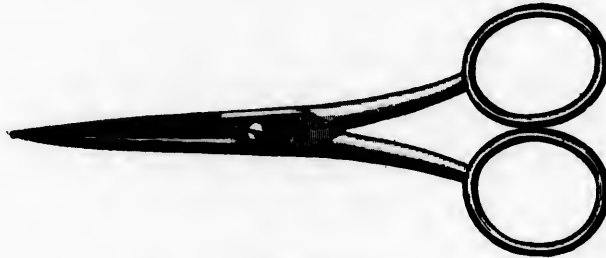

No. 6041, 4 inch.

No. 6041—H. Boker & Co.'s, Lace, Fine Polish, 4 inch per doz. \$4.05

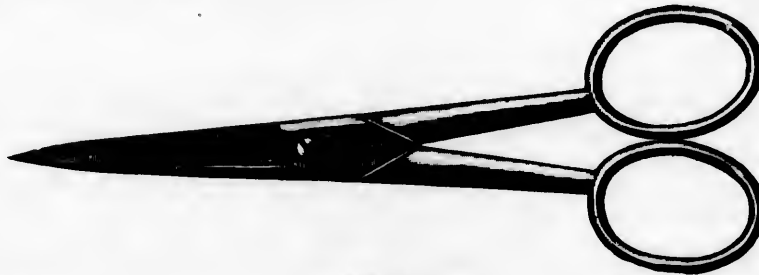

No. 6041, 5 inch.

No. 6041—H. Boker & Co.'s, Tailors' Points, Fine Polished, 5 inch per doz. \$5.50

Length
No. 412
" 512
" 612
" 612
" 612
" 612

POCKET SCISSORS

Full size cuts.

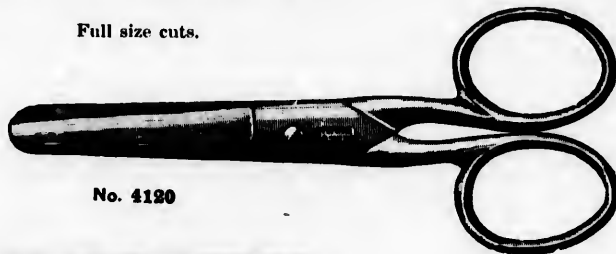

No. 4120



No. 5173

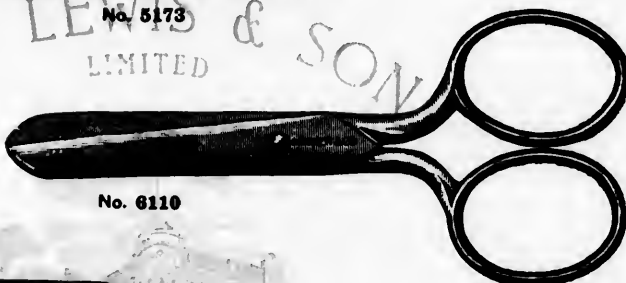

No. 6110

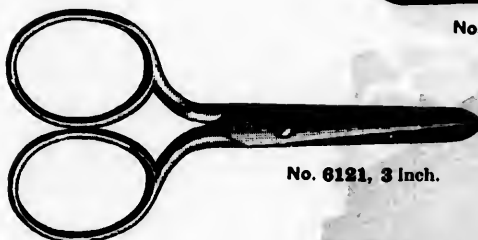

No. 6121, 3 inch.

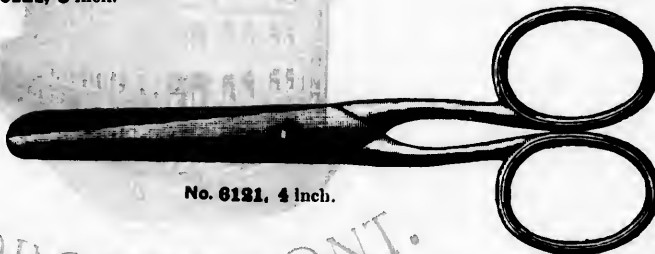

No. 6121, 4 inch.

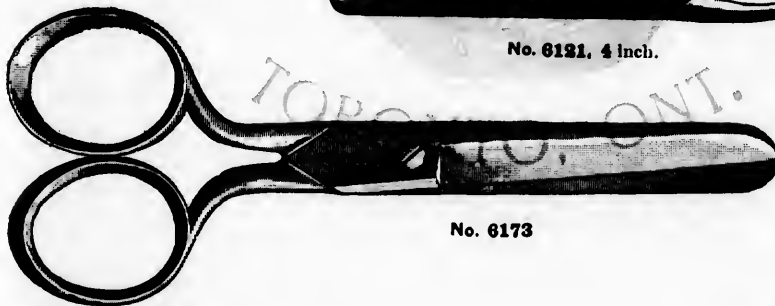

No. 6173

Length	3	3½	4	4½	5 inch.
No. 4120—Edwards', all Bright.....	per doz.	1.95
" 5173—Crown Cutlery Co.'s, Full Nickel-Plated	"	3.50	3.70
" 6110—H. Boker & Co.'s, Full Polished	"	2.95	3.25
" 6121— " " Fine Finish, Slim Pattern	3.30	4.10
" 6173— " " Full Nickel-Plated	"	4.50	4.75	5.00
" 9100—Turner & Co.'s, Full Polished, pattern as No. 6110....	"	4.75



3¼ inch.
\$5.55
9.75



3½ inch.
\$6.40
6.40

doz. \$4.05

doz. \$4.55

POCKET SCISSORS

Full size cuts.

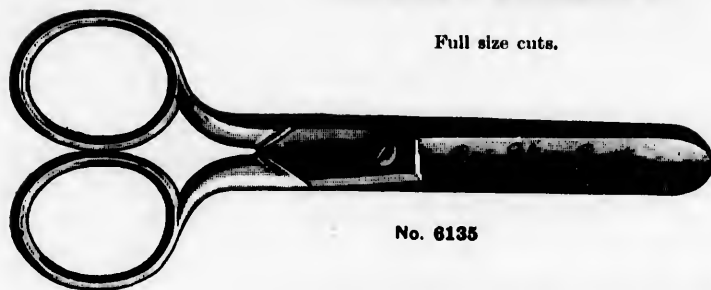

No. 6135

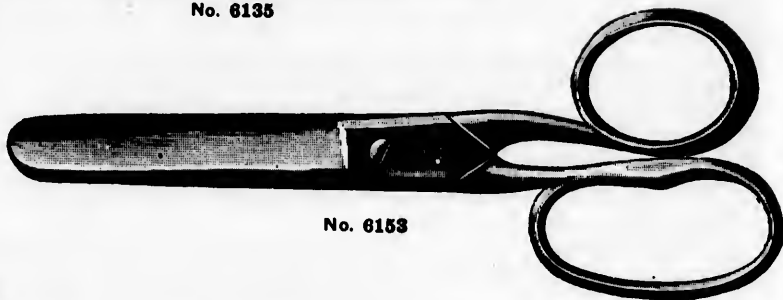

No. 6153

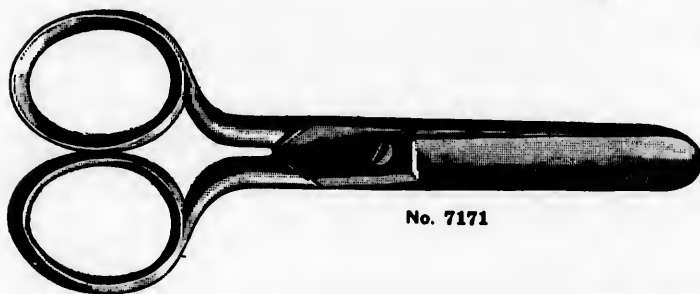

No. 7171

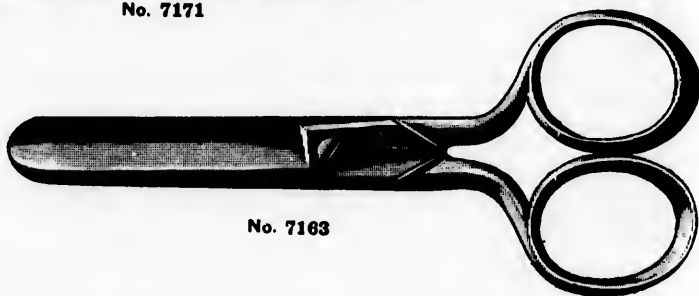

No. 7163

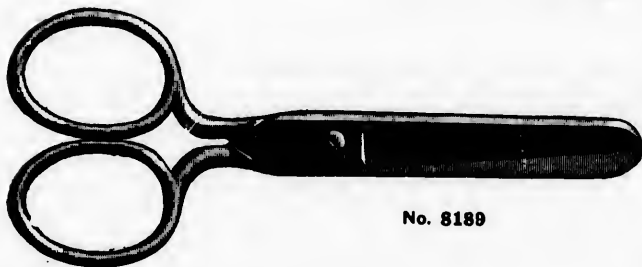

No. 8189

Length.....	4	4½	5	6, inch.
No. 6153—H. Boker & Co.'s, Full Nickel-Plated..... per doz.	\$....	5.35	5.80
" 6135— " " Gilt Handle, Fine Polished Steel Blade.... "	6.10	6.55
" 7171— " " "Tree Brand," Fine Polished..... "	8.00	8.55
" 7163— " " " Full Nickel-Plated..... "	6.10	6.70	7.50	9.50
" 8189— " " "King Cutter," Fine Mirror Polished, Round				
Bows..... per doz.	10.65	11.55	12.50

Length
No. 54
" 54
" 54
" 64
" 74
" 84

BUTTON-HOLE SCISSORS

REGULATING

Full size cuts.

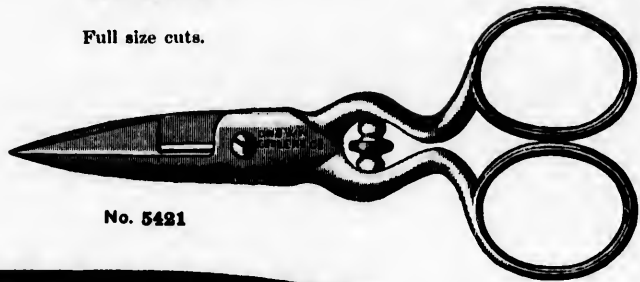

No. 5421

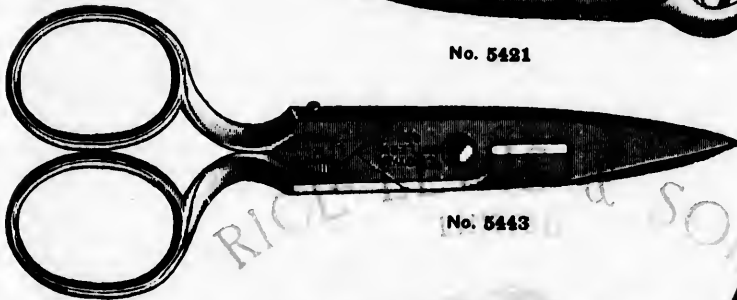

No. 5443

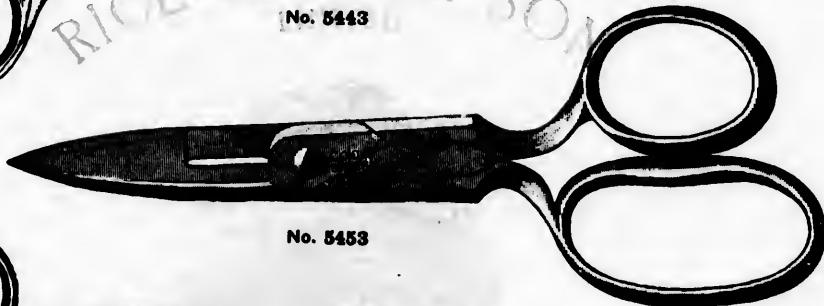

No. 5453

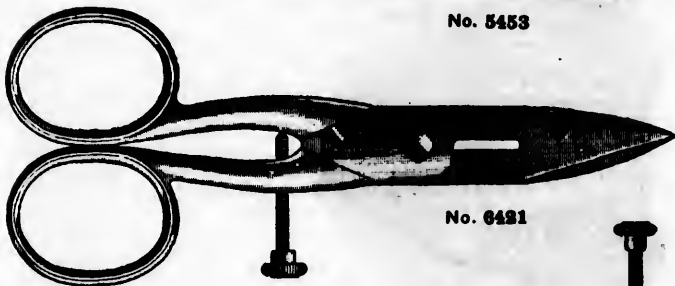

No. 6421

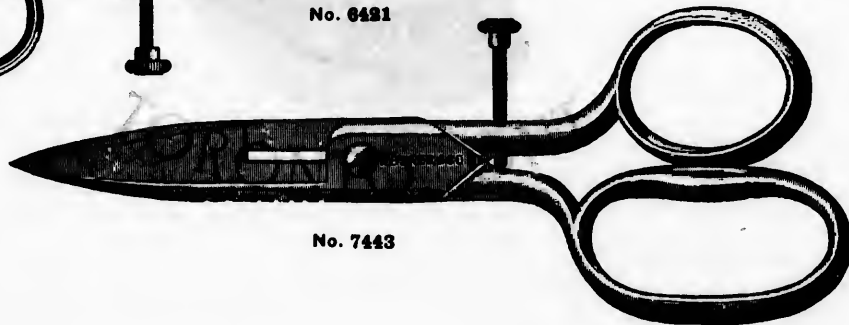

No. 7443

6, inch.

Length		3½	4	4½	5	5½ inch.
No. 5421—Crown Cutlery Co.'s, Polished.....	per doz.	5.30	5.40
" 5443— " " Full Nickel-Plated	"	6.70
" 5453— " " " "	"	8.80
" 6421—H. Boker & Co.'s, Polished	"	5.55
" 7443— " " "Tree Brand," Full Nickel-Plated..	"	10.90
" 9400—Turner & Co.'s, Full Polished, pattern as No. 5421.....	"	\$9.45

NAIL SCISSORS

Full size cuts.

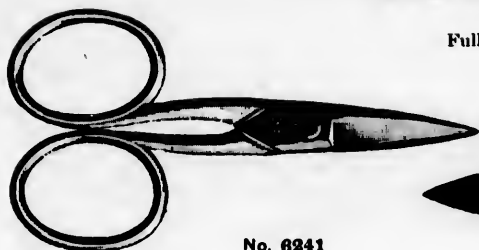

No. 6241



No. 6240

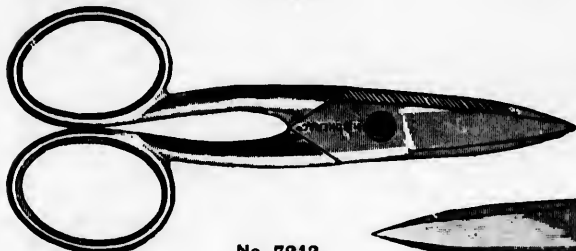

No. 7243



No. 6273

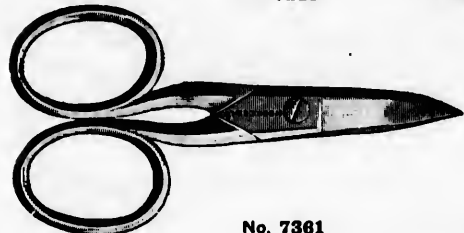

No. 7361

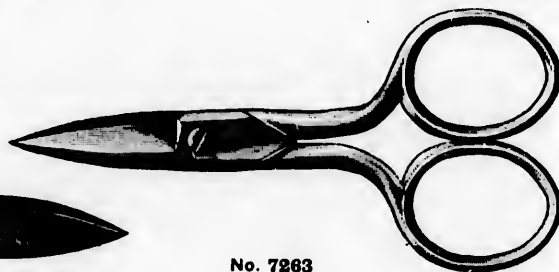

No. 7263

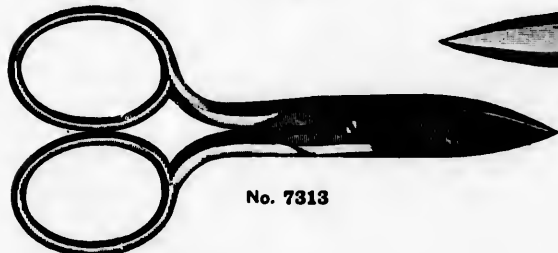

No. 7313

Length		3	3½	3¾	4	inch.
No. 6240	H. Boker & Co.'s, Polished	per doz.	2.95
" 7341	Bent, " " "Tree Brand," Fine Polished, pattern as No. 6240	"	0.20
" 6241	Bent, " " "Tree Brand," Fine Polished	"	5.30
" 6273	Bent, " " Full Nickel-Plated	"	4.65
" 6373	Bent, " " " " " " pattern as No. 6273	"	7.15
" 7243	Bent, " " "Tree Brand," Nickel-Plated Handles, Fine Polished Blades	"	6.35
" 7263	Bent, " " "Tree Brand," Full Nickel-Plated	"	6.45
" 7363	Bent, " " " " " " pattern as No. 7263	"	9.50
" 8389	Bent, " " "King Cutter," Fine Mirror Polished, Round Bows	"	10.75
" 8389	Bent, " " " " " " " " " " " "	"
" 7361	Bent, " " " " " " pattern as No. 7263	"	14.05
" 7361	Bent, " " "Tree Brand," Fine Polished	"	8.15
" 6361	Bent, " " Fine Polished, pattern as No. 7361	"	6.00
" 7313	Bent, " " "Tree Brand," Nickel-Plated Handles, Polished Blades	"	11.25

NAIL SCISSORS

Two-thirds size cuts.



Length		2 3/4	3	3 1/4	3 1/2	4	inch.
No. 9200—Turner & Co.'s Full Polished, Large Bows, with Leather Case, per doz.		\$9.45	
" 9201— " " " " " " " " " " " "		5.25	
" 9203— " " " " " " " " " " " "		7.45	
" 9204— " " " " " " " " " " " " Large Bows.....		0.45	11.50	12.85	

TURNER'S BENT NAIL AND MANICURE SCISSORS



Length		3 1/2	4	4 1/4	inch.
No. 9300—Bent, Turner & Co.'s, Full Polished	per doz.	\$18.25	
" 9301— " " " " " " " " " " " "		12.50	
" 9800—Straight, " " " " " " " " " " " " Manicure Scissors.....		11.80	
" 9802—Bent, " " " " " " " " " " " " " "		20.25	
" 9803— " " " " " " " " " " " " " " Heavier " "		21.00	



4 inch.
9.20
4.65
7.15

HORSE CLIPPING OR CATTLE MARKING SCISSORS

Two-thirds size cuts.

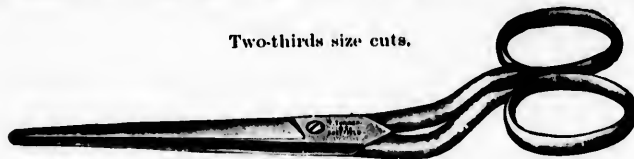

No. 9601

Length.....	5½	6½ inch.
No. 9601—Turner & Co.'s, Bent Handle, Straight Blades, Polished.....	per doz. \$8.10	10.85



No. 9600

Length.....	6½	inch.
No. 9600—Turner & Co.'s, Bent Handle, Curved Blades.....	per doz. 14.85	11.55
" 9621—Boker's Bent Handle, Curved Blades with Fine Tooth Cut Edges.....	" "	"

SCISSORS IN CASES

Two-thirds size cut.

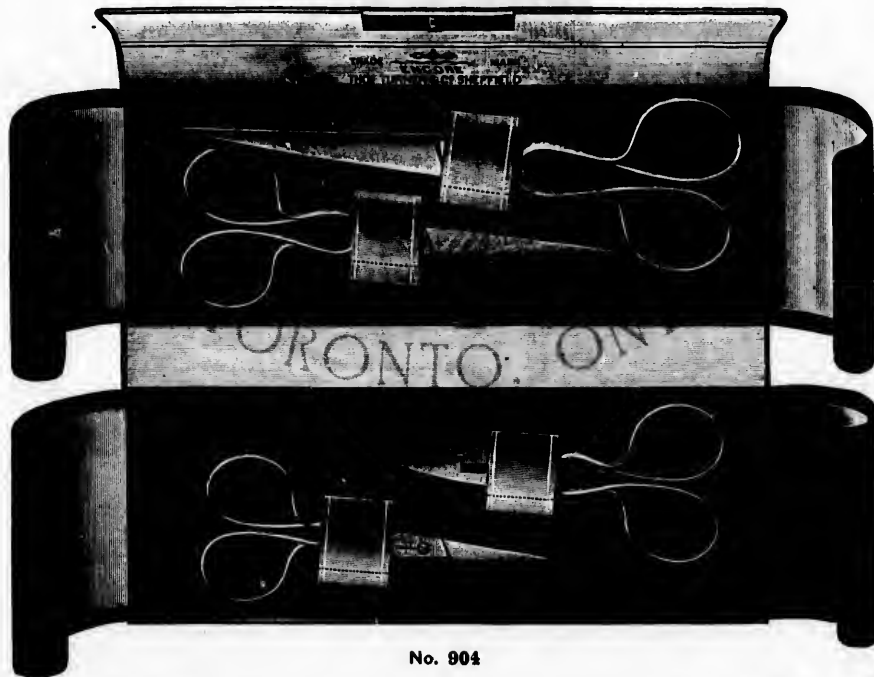

No. 904

Number of Scissors in Case.....	3	4 pair.
No. 904—Genuine Crocodile Case, Dark Green, Turner's Fine Polished Scissors....	per case \$5.25	5.95

SCISSORS IN CASES



No. 905

Two-thirds size cut.



No. 901

Two-thirds size cut.

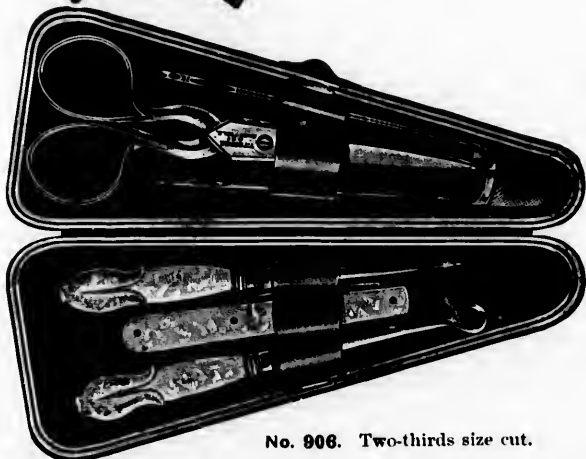

No. 906. Two-thirds size cut.

Number of Scissors in Case	3	5 pairs.
No. 905—Best Calf Case, Grained, Dark Green, Turner's Full Polished Scissors..... per case.	\$5.75
" 901— " " Dark Green or Dark Red, Plush and Silk Lined, Turner's Polished Scissors	\$4.40
" 906—Turner's Ladies' Companion, Leather Covered Case, Dark Green or Dark Red, Contains 1 pair 4 1/2 inch Scissors, 1 Pearl Handled Penknife, Button Hook and Stiletto, 1 Steel Bodkin and Tape Needle, and Stirling Silver Thimble. . per case.	5.10

Number
 No. 90
 " 60
 " 60
 " 60
 " 60
 " 60
 " 60
 " 90
 " 90
 " 60

SCISSORS IN CASES

Two-thirds size cuts.



No. 900



No. 902



No. 903



No. 605

Number of Scissors in Case	3	4	5	6
No. 900—Pig Skin Case, Buff, Plush Lined, Turner's, Full Polished Scissors, per case	\$2.70	3.40
" 600—Grained Leather Case, Boker's, Full Polished Scissors	1.00
" 601—" " " " Fine " " Oval Shank and Bows	"	2.70
" 602—Plush Case, Crimson, Blue or Old Gold, Boker's, Fine Polished Scissors	"	3.40
" 603—Best Calf Case, Dark Green or Dark Red, Boker's, "Tree Brand" Mirror Polished Scissors, Silver-Plated Fancy Handles	"	5.00
" 604—Best Calf Case, Dark Green or Dark Red, Boker's, "Tree Brand" Mirror Polished Scissors, Silver-Plated Handle, Round Bows	"	5.00
" 902—Best Calf Case, Dark Green or Dark Red, Plush and Silk Lined, Turner's, Fine Polished Scissors with Silver-Plated Handles	"	4.40	5.75	7.10 0.15
" 903—Pig Skin Case, Dark Brown Color, Plush and Silk Lined, Turner's, Fine Polished Scissors with Silver-Plated Handles	"	5.10	6.10	7.00
" 605—Russian Leather Case, Plush Lined, Boker's, Polished Scissors, Gilt Handles	"	2.80

Cases for Nos. 600 to 604 same style of case as No. 900.

BUTTER KNIVES



No. 9192

No. 9192—Ebony Straight Handle, 8 inch Solid Nickel Silver Bladeper doz. \$14.85



No. 9152

No. 9152—Ebony Cranked Handle, 9 inch Solid Nickel Silver Bladeper doz. 18.25

BUTTER AND LARD SPADE



No. 08½

No. 08½—Cocobolo Handle, Metal Bolster, Forged and Tempered Steel Blade, Tinnedper doz. 11.00
 " 9161—Cocoa Handle, Round, 5 inches long through Tang, Steel Blade, 8½ x 3 inch, Silver-Plated. 21.50

BUTTER AND LARD TROWEL



No. 16—6 inch, Plated with Pure Block Tinper doz. 7.20
 " 18—7 " " " " " " " 8.50

Length
No. 80

" 81

Size...

No. 50

" 60

" 70

" 80

No. 17

" 3

No. 17

" 3

BUTTER AND CHEESE TRYERS



No. 801



No. 500



No. 900 Full size cut.

Length.....	16	18	20	inch.
No. 801—Wood Handle, Best Cast Steel Blade, Riveted Through Handle, Ground Thin, Tapering $\frac{3}{4}$ to $\frac{1}{2}$ inch, Full Polished, Nickel-Plated....	\$15.00	10.50	18.30	per doz.
" 811—Wood Handle, Trowel Shank, Best Cast Steel Blade, Riveted Through Handle, Ground Thin, Tapering $\frac{3}{4}$ to $\frac{1}{2}$ inch, Full Polished, Nickel-Plated	43.00	54.50	per doz.
Size.....	4 x $\frac{1}{4}$	4 x $\frac{1}{2}$	6 x $\frac{1}{2}$	inch.
No. 500—Cast Steel, Polished.....	\$3.70	4.10	per doz.
" 600— " Full Nickel-Plated, Pattern as No. 500	1.50	5.20	per doz.
" 700—Best Cast Steel, Full Polished, Nickel-Plated, Ground Specially Thin "	\$5.00	11.00	per doz.
" 900—Pocket Cheese Tester, Cast Steel Blade, Ground Thin, Full Polished and Nickel-Plated	\$8.00	per doz.

PUTTY KNIVES



No. 1735

No. 1735—Boker's, Stained Handle, Iron Ferrule.....	per doz.	\$2.40	
" 321—Rodgers', Riveted Cocoa Handles, Iron Bolster.....	"	3.55	



No. 1736

No. 1736—Boker's, Stained Handle, Iron Ferrule.....	per doz.	2.40	
" 301—Rodgers', Riveted Cocoa Handles, Iron Bolster.....	"	3.55	

PUTTY KNIVES



No. 1737

No. 1737—Boker's, Stained Handle, Iron Ferrule	per doz.	\$2.40
“ 301—Rodgers', Riveted Cocoa Handles, Iron Bolster		3.55



No. 150

No. 150—Russell's, Round Point, Riveted Redwood Handle, Iron Ferrule	per doz.	3.75
“ 150— “ Square “ “ “ “ “		3.75
“ 150— “ Chip “ “ “ “ “ “		3.75

HACKING KNIVES



No. 8356

No. 8356—Boker's, Leather Handle Hacking Knife	per doz.	3.60
“ 0—Russell's, “ “ “ “ “ “		7.65

SCRAPING KNIVES



No. 525

Width of Blade	2 $\frac{3}{4}$	3	3 $\frac{1}{2}$ inch.
No. 525—Russell's, Riveted Redwood Handle	\$9.35	10.00
“ 331—Rodgers', “ Cocoa “ Iron Ferrule	8.15



No. 1742

Width of Blade	2 $\frac{1}{2}$	3	3 $\frac{1}{2}$ inch.
No. 1742—Boker's, Stained Handle, Iron Ferrule	\$2.95	3.00	3.25

KITCHEN KNIVES



No. 375A. Half size cut.

No. 375A—Boker's, Reveted Beechwood Handle, 3 inch Polished Blade.....per doz. \$1.00



No. 373. Half size cut.

No. 373—Boker's, Reveted Beechwood Handle, 3 inch Polished Blade.....per doz. 1.00



No. 15. Half size Cut.

No. 15—Goodell's, Rosewood Handle, Iron Bolster, 3 inch Polished Blade.....per doz. 1.40



AETNA

No. 1—Aetna, Beechwood Handle, Brass Ferrule, 3½ inch Blade.....per doz. 1.50



DIAMOND

Diamond, Beechwood Handle, Iron Ferrule, 4 inch Blade.....per doz. 3.50

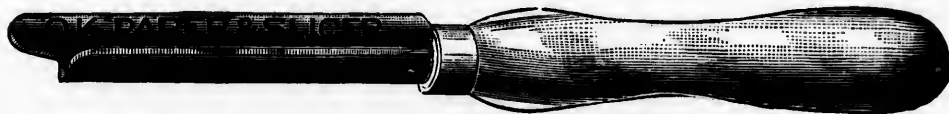

O.K. Full size cut.

O.K.—Parer and Slicer, Black Japanned Handle, Tinned Blade.....per doz. 1.20



No.
Length
No. 261
" 271
" 272
" 273

BREAD KNIVES

oz. \$1.00
 doz. 1.00
 doz. 1.40
 doz. 1.50
 doz. 3.20
 doz. 1.20



No. 261



No. 271



No. 2



No. 22

Length of Blade	6½	7½	8 inch.
No. 261 - Rodgers', Carved Boxwood Handle	per doz.	\$0.40	8.85
" 271 - " Plain Beechwood Handle			6.00
" 2 - Etna, Polished Beechwood Handle, 10-inch Blade	per doz.		\$3.30
" 22 - Quick Cut, Nickel-Plated Handle and Blade, 10-inch Blade			2.50

RODGERS' BUTCHERS' KNIVES



No. 211

Length of Blade.....	5	5½	6	6½	7	8	9	10	12	14	inch.
No. 211—Rosewood Handle..... per doz.	\$4.45	4.80	5.15	5.50	6.40	7.45	9.20	11.00	17.70	13.20	

SKINNING



No. 221

Length of Blade.....	5	5½	6	inch.
No. 221—Rosewood Handle..... per doz.	4.45	4.80	5.15	

STICKING

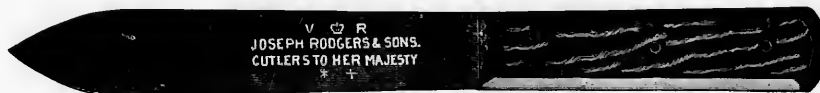

No. 231

Length of Blade.....	6	inch.
No. 231—Rosewood Handle..... per doz.	5.15	



No. 241

Length of Blade.....	5	5½	6	6½	7	inch.
No. 241—Beechwood Handle..... per doz.	\$3.00	3.20	3.40	3.75	4.00	



No. 251

Length of Blade.....	5	5½	6	6½	7	inch.
No. 251—Beechwood Handle..... per doz.	\$3.00	3.20	3.40	3.75	4.25	

No. . .
Length
Per doz.

No. . . .
Length
Per doz.

No. 22

Length
No. 477

Length
No. 477

No. 480

JOHN WILSON'S BUTCHERS' KNIVES



Beechwood Handle.				Rosewood Handle.					
No.	28	29	30	43	No.	28R	29R	30R	43R
Length of Blade.....	5½	6	6½	7 inch.	Length of Blade.....	5½	6	6½	7 inch.
Per dozen.....	\$3.75	4.35	4.05	5.80	Per dozen.....	\$4.05	5.25	5.80	6.05

14 inch.
13.20

SKINNING



Beechwood Handle.				Rosewood Handle.			
No.	128	129			No.	128R	129R
Length of Blade.....	5½	6 inch.			Length of Blade.....	5½	6 inch.
Per dozen.....	3.75	4.35			Per dozen.....	4.65	5.25

6 inch.
5.15

STICKING



Beechwood Handle.		Rosewood Handle.	
No. 229—6 inch, Sticking.....	per doz. \$4.35	No. 229R—6 inch, Sticking.....	per doz. \$5.25

ASKHAM'S "WAPACUT" BUTCHERS' KNIVES



Length.....	5	5½	6	7	8	9	10 inch.
No. 475—Butcher, Beechwood Handle.....	per doz. 3.80	4.20	4.20	5.20	6.75	8.75	9.95

6 inch.
5.15

SKINNING



Length.....	5	5½	6 inch.
No. 477—Skinning, Beechwood Handle.....	per doz. 4.20	5.20	5.20

7 inch.
4.60

STICKING

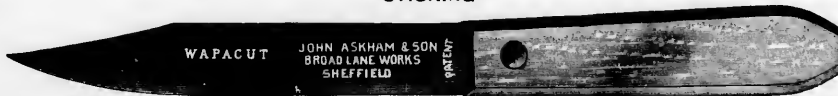

No. 480—6 inch, Sticking, Beechwood Handle.....	per doz. 4.20
---	---------------

7 inch.
4.25

NICHOLS BROS.' BUTCHERS' KNIVES



No.	25	25½	26	26½	27	28	29	
Length of Blade.....	5	5½	6	6½	7	8	9	inch.
Beechwood Handle.....per doz.	\$3.40	3.85	4.00	4.95	5.75	7.25	8.00	

SKINNING



No.	45	45½	46	
Length of Blade.....	5	5½	6	inch.
Beechwood Handle.....per doz.	\$3.40	4.00	4.65	

STICKING



No. 36

No. 36—6 inch Blade, Beechwood Handle.....per doz.	\$4.65
--	--------

NICHOLS' NEW YORK PATTERN LAMB SPLITTER



12 x 2½ inch Blade, Hand Made from Silver Tool Steel, Riveted Beechwood Handle.....per doz.	\$22.00
14 x 2½	35.20

NICHOLS' SPLITTING KNIFE



No. 312

No. 312—12 inch, Forged Steel Blade, Beechwood Handle, for Splitting Small Stock.....per doz.	19.80
" 312X—12 " " " " Extra Heavy	23.10

SHEFFIELD CHOPPING KNIFE



No. 9772

No. 9772—Turner's, Sheffield Chopping Knife, 12 x 2½ inch Blade, 6½ inch Ebony Handle, Scale Tanged.....per doz.	\$32.50
--	---------

TURNER'S BACON KNIFE



No. 9731

No. 9731—10 inch Blade, Beechwood Handle, Iron Ferrule.....per doz. \$12.25

NICHOLS' STEAK KNIFE



Nos.....	210	212	
Length of Blade	10	12	14 inch.
Beechwood Handle.....	per doz. \$10.55	16.50	16.50

NICHOLS' CIMETER BLADE STEAK KNIFE



Nos.....	010	012	014	
Length of Blade	10	12	14	inch.
Beechwood Handle	per doz. \$10.55	16.50	23.10	

NICHOLS' PORK KNIFE



No. 410—10 inch Blade, Beechwood Handle.....per doz. \$10.55

NICHOLS' BONING KNIFE



No. 40—6 inch Blade, Beechwood Handle.....per doz. 4.00

NICHOLS' COOKS' LEANING KNIFE



No. 912—12 inch Blade, Cocoa Handle.....per doz. 16.50

COOKS' OR "SABATIER" KNIVES AND COOKS' FORKS



COOKS' KNIFE



No. 9741



No. 895



No. 8752

COOKS' FORKS

		Per doz.
No. 895	Nichols', Cocoa Handle, Full Length, 13 in. . .	\$5.00
" 8752-6 in.	Boker's, Ebony " " " " " " " " " " " "	11 " . . 10.80
" 8752-8 "	" " " " " " " " " " " "	13 " . . 11.00
" 8752-9 "	" " " " " " " " " " " "	14 " . . 12.20
" 9741	Turner's, Beech " " " " " " " " " " " "	13 " . . 7.80

COOKS' OR "SABATIER" KNIVES

Length of Blade.	5	6	8	9	10	11	12	inch.
No. 202—Rodgers', Ebony Handle per doz.	\$11.00	13.10	17.00	21.05	
" 8202—Boker's " " " " " " " " " " " "	\$2.90	4.00	5.80	7.40	8.50	9.80

BEEF AND HAM SLICERS

BEEF SLICERS



No. 712—Nichols', 12 x 1 1/4 inch Blade, Cocobolo Handle, Octagon Shape	per doz.	\$16.50
" 714— " 14 x 1 1/4 " " " "	"	19.80
" 716— " 10 x 1 1/4 " " " "	"	23.10

HAM SLICERS



No. 78—Nichols', 10 inch Swaged Blade, Clip Point, Fancy Bolster, Ebony Handle	per doz.	9.00
--	----------	------



No. 9701

No. 9701—Turner's, 10 x 3/4 inch Blade, Rosewood Handle	per doz.	8.75
" 9701— " 11 x 3/4 " " "	"	11.25
" 9706— " 10 x 3/4 " " Clip Point, Celluloid Handle	"	16.90



No. 9714

No. 9714—Turner's, 10 inch Blade, Stag Handle, German Silver Mounted	per doz.	24.35
" 9724— " 10 " " Clip Point, Stag Handle, as No. 9714	"	32.40
" 9724— " 12 " " " " " " " "	"	36.45

TROWEL SHANK KNIVES AND FORKS

Per doz.

13 in. . .	\$5.00
11 " ..	10.80
13 " ..	11.00
14 " ..	12.20
13 " ..	7.80



No. 9414

No. 9414—Turner's, 12 inch, with Cockscur Fork, Stag Handle, G. S. Mounts	per pair.	8.10
" 2427—Rodgers', 10 inch, with Fork, Flat Ivory Handle	"	9.90

12 inch.	
21.95	
9.80	



Nos. 5354	5454	5414	5384	2354	2364	
No. 5354—Wostenholm's, 8 inch Blade, Stag Handle.....						per pair \$1.75
" 5454—	" 9 "	" " " " "	" " " " "	" " " " "	" " " " "	2.45
" 5414—	" 9 "	" " " " "	" " " " "	" " " " "	" " " " "	3.35
" 5384—	" 9 "	" " " " "	" " " " "	" " " " "	" " " " "	2.65
" 5036—	" 8 "	" " " " "	" " " " "	" " " " "	" " " " "	2.90
" 5046—	" 8 "	" " " " "	" " " " "	" " " " "	" " " " "	2.90
" 5066—	" 8 "	" " " " "	" " " " "	" " " " "	" " " " "	3.10
" 2354—Rodgers',	" 8 "	" " " " "	" " " " "	" " " " "	" " " " "	1.45
" 2354—	" 9 "	" " " " "	" " " " "	" " " " "	" " " " "	1.70
" 2354—	" Game, 6 "	" " " " "	" " " " "	" " " " "	" " " " "	1.45
" 2364—	" 9 "	" " " " "	" " " " "	" " " " "	" " " " "	3.40
" 2364—	" Game, 6 "	" " " " "	" " " " "	" " " " "	" " " " "	3.40

Nos. 2
No. 23
" 23
" 23
" 23
" 20
" 20
" 20
" 20
" 20
" 21
" 21
" 20
" 20
" 20
" 20



PRICE LEWIS & SONS LIMITED

TORONTO, ONT.

Nos.	2384	2374	2087SP	2126 and 2077	2066 and 2067
No. 2384—Rodgers', 9 inch, Spanish Blade, Stag Handle, E. P. Mounts				per pair. \$4.45
" 2384	" 9 "	" "	" "	" "	3.55
" 2384	" Game, 6 "	" "	" "	" "	3.55
" 2374	" 9 "	Saracenic	" "	" "	3.55
" 2374	" Game, 6 "	" "	" "	" "	3.55
" 2087SP	" 8 "	Spear	Ivory	" "	5.20
" 2087	" 8 "	Spanish	" "	Handle as No. 2087SP	5.85
" 2046	" 8 "	" "	Ivoroide	" "	2.85
" 2046	" 8 "	" "	" "	" "	2.85
" 2046	" Gam, 6 "	" "	" "	" "	2.50
" 2126	" 8 "	" "	" "	" "	5.85
" 2077	" 8 "	" "	Ivory	" "	3.00
" 2066	" 8 "	" "	Ivoroide	" "	8.80
" 2067	" 8 "	" "	Ivory	" "	9.05
" 2067	" 9 "	" "	" "	" "	8.80
" 2067	" Game, 6 "	" "	" "	" "	

364
\$1.45
2.45
3.35
2.95
2.90
2.90
3.10
1.45
1.70
1.45
3.40
3.40

TURNER'S CARVERS



No. 9076

- No. 9076—8 inch, Encore Blade, "Ivorygrain" Handle.....per pair. \$2.70
 " 9076—Game, 6 inch, Encore Blade, "Ivorygrain" Handle....." 2.70



No. 9086

- No. 9086—8 inch, Encore Blade, "Ivorygrain" Handle.....per pair. 2.70
 " 9086—Game, 6 inch, Encore Blade, "Ivorygrain" Handle....." 2.70



No. 9087 and 9086

- No. 9087—8 inch, Encore Blade, Ivory Handle.....per pair. 5.40
 " 9086—8 " " "Ivorygrain" Handle....." 3.40
 " 9086—Game, 6 inch, Encore Blade, "Ivorygrain" Handle....." 3.40



No. 9316 and 9317

- No. 9317—8 inch, Encore Blade, Ivory Handle.....per pair. 6.75
 " 9307—8 " " "Lighter than No. 9317....." 4.75
 " 9316—8 " " "Ivorygrain" Handle....." 3.70



No. 9297

- No. 9297—8 inch, Encore Blade, Ivory Handle, Sterling Silver Ferrule.....per pair. 6.75
 " 9286—8 " " "Ivorygrain" Handle, Sterling Silver Ferrule....." 3.40
 " 9286—9 " " " " " " " " " " " " " " " " " 3.70
 " 9286—Game, 6 inch, Encore Blade, "Ivorygrain" Handle, Sterling Silver Ferrule....." 3.40
 " 9327—8 inch, Encore Blade, Ivory Handle (Handle as Table Knife No. 9327, page 957)....." 6.10
 " 9326—8 " " "Ivorygrain" Handle (Handle as Table Knife No. 9326, page 955)....." 3.40
 " 9337—8 " " "Ivorygrain" Handle (Handle as Table Knife No. 9337, page 957)....." 6.40
 " 9347—8 " " " " " " " " " " " " " " " " " 6.75
 " 9277—8 " 7.00
 " 9236—Game, 6 inch, Encore Blade, "Ivorygrain" Handle, E. P. Mounts (Handle as Table Knife No. 9236, page 958)....." 7.10
 " 9266—Game, 6 inch, Encore Blade, "Ivorygrain" Handle, Sterling Silver Ferrule (Handle as Table Knife No. 9266, page 955)....." 4.40
 " 9428—8 inch, Encore Blade, Pearl Handle, E. P. Ferrule (Handle as Table Knife No. 9428, page 958)....." 15.20
 " 9438—8 inch, Encore Blade, Pearl Handle, E. P. Ferrule (Handle as Table Knife No. 9438, page 958)....." 9.45

MEAT CARVERS IN CASES

One-quarter size cuts.

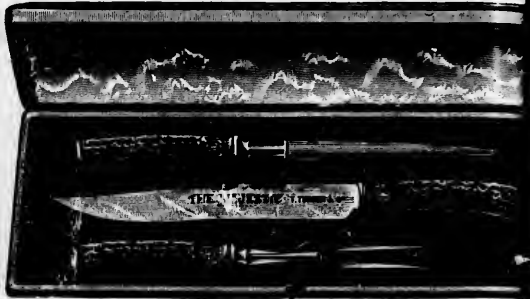

No. 934		No. 944	
No. 934-3	pieces, Stag Handles, E. P. Mounts, Morocco Case, Silk and Plush Lined		\$ 6.25
" 944-3	" " " " " " " " " " " "		9.50
" 944-5	" " " " " " " " " " " "		15.50



No. 954		
No. 954-3	pieces, Stag Handles, E. P., Mounts, Morocco Case, Silk and Plush Lined	12.25
" 954-5	" " " " " " " " " " " "	20.00

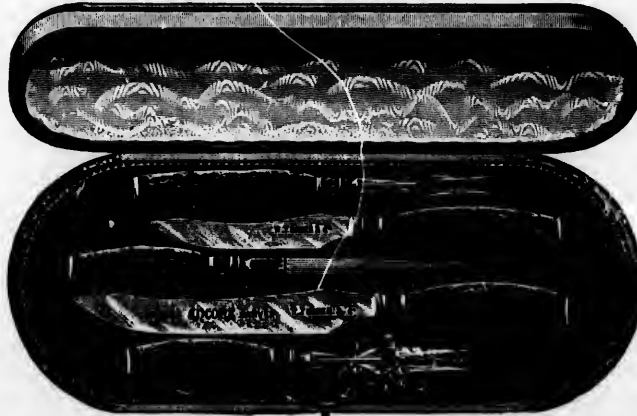

No. 964		Per Case
No. 964-3	pieces, Black Forest Stag Handles, Sterling Silver Mounts, Morocco Case, Silk and Plush Lined	20.00
" 964-5	" " " " " " " " " " " "	31.50

Length
No. 26

Length
No. 26

Length
No. 26

Length
No. 515

Length
No. 502

Length
No. 102

Ar
sible T

BUTCHERS' STEELS

JOSEPH RODGERS & SONS'

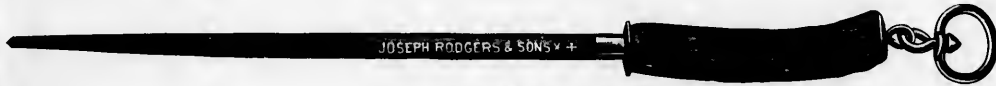

No. 2604

Length..... 9 10 12 inch.
 No. 2604—Stag Handle, Iron Ring and Swivel..... per doz. \$11.70 12.55 18.25



No. 2614

Length..... 12 14 inch.
 No. 2614—Stag Handle, Brass Ring and Ferrule..... per doz. 33.25 38.95



No. 2621

Length..... 9 10 12 14 inch.
 No. 2621—Boxwood Handle, Brass Ring and Ferrule..... per doz. 11.00 13.10 17.70 21.95

ASKHAM'S BUTCHERS' STEELS

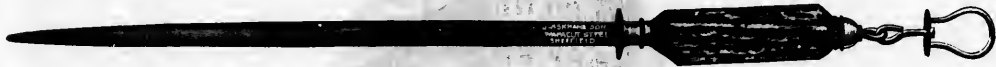

No. 515

Length..... 12 14 inch.
 No. 515—Stag Handle, Iron Ring and Swivel..... per doz. 9.55 12.55



No. 502

Length..... 10 12 inch.
 No. 502—Rosewood Handle, Iron Ring and Swivel..... per doz. 10.75 12.75

LEE'S BUTCHERS' STEELS

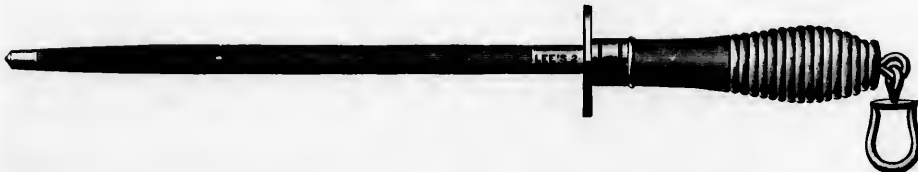

Length..... 10 12 14 inch.
 No. 102—Beechwood Handle, Tinned Iron Swivel..... per doz. 11.00 13.50 17.00

Are made from the best quality of tool steel and are hardened by a process that makes "soft spots" impossible. The edges are formed by 300 deep narrow teeth, extending without break from heel to point.

\$ 6.25
 9.50
 15.50

12.25
 20.00

Per Case
 20.00
 31.50

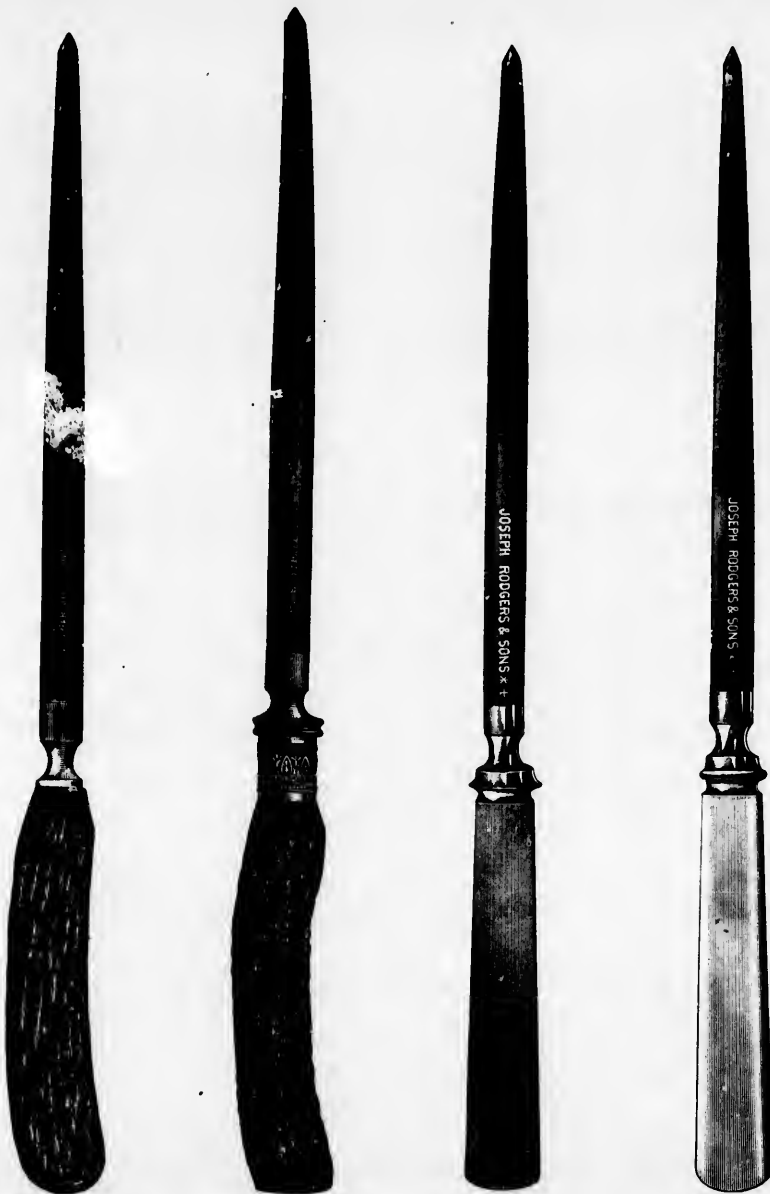

No. 2114

No. 2374

No. 2097

No. 2067 and 2066

No. 2114	Rodgers', 7 inch, Plain Stripped Steel, Stag Handle	per doz.	\$80.05
" 2354	" 8 " " " " " (Heavy, Flat End)	"	7.10
" 2374	" 8 " " " " " E. P. Ferrule	"	21.95
" 2384	" 8 " " " " " Patn. of Handle as Carver No. 2384, on page 930	"	21.95
" 2394	" 8 " " " " " " 2394, " 930	"	27.00
" 2097	" 8 " " " " " Ivory Handle (Flat, Round End)	"	23.80
" 2087	" 8 " " " " " " " " " " " " " "	"	33.45
" 2066	" 8 " " " " " " " " " " " " " "	"	9.55
" 2077	" 8 " " " " " " " " " " " " " "	"	22.90
" 2046	" 8 " " " " " " " " " " " " " "	"	8.50
" 2103	" 8 " " " " " " " " " " " " " "	"	7.10
			Table Knife No. 2103, p. 952

No. 947
" 948

No. 947
" 947
" 952
" 951

No. 9484
" 9484

No. 9564

No. 9076
" 9076
" 9086

TURNER'S TABLE STEELS



No. 9454 $\frac{1}{2}$, ENCORE BLADE

- | | | |
|---|----------|---------|
| No. 9454 $\frac{1}{2}$ —8 inch, Plain Stripped Steel, Stag Handle | per doz. | \$10.15 |
| “ 9454 $\frac{1}{2}$ —8 “ “ Encore “ “ | | 16.20 |



No. 9474 $\frac{1}{2}$, ENCORE BLADE

- | | | |
|---|----------|-------|
| No. 9474 $\frac{1}{2}$ —8 inch, Plain Stripped Steel, Stag Handle, E. P. Mounts | per doz. | 18.25 |
| “ 9474 $\frac{1}{2}$ —8 “ “ Encore “ “ | | 24.30 |
| “ 9524 $\frac{1}{2}$ —8 “ “ “ “ “ “ Sterling Silver Mounts (Pattern of Handle as Carver No. 9524, page 941) | per doz. | 52.05 |
| “ 9514 $\frac{1}{2}$ —8 inch, Encore Steel, Stag Handle, E. P. Mounts (Pattern of Handle as Carver No. 9514, page 941)..... | per doz. | 22.30 |



No. 9484 $\frac{1}{2}$ and 9494 $\frac{1}{2}$, ENCORE BLADE

- | | | |
|---|----------|-------|
| No. 9484 $\frac{1}{2}$ —8 inch, Encore Steel, Stag Handle, E. P. Mounts | per doz. | 22.30 |
| “ 9494 $\frac{1}{2}$ —8 “ “ “ “ “ “ Sterling Silver Mounts..... | | 58.75 |



No. 9584 $\frac{1}{2}$, ENCORE BLADE

- | | | |
|---|----------|-------|
| No. 9584 $\frac{1}{2}$ —8 inch, Encore Steel, Stag Handle, Sterling Silver Mounts | per doz. | 36.45 |
|---|----------|-------|



No. 9076 $\frac{1}{2}$, ENCORE BLADE

- | | | |
|---|----------|-------|
| No. 9076 —8 inch, Plain Stripped Steel, “Ivorygrain” Handle (Pattern of Handle as No. 9076 $\frac{1}{2}$) ... per doz. | 12.15 | |
| “ 9076 $\frac{1}{2}$ —8 inch, Encore Steel, “Ivorygrain” Handle | | 18.25 |
| “ 9086—8 inch, Plain Stripped Steel, “Ivorygrain” Handle (Pattern of Handle as Carver No. 9086, on page 942)..... | per doz. | 12.15 |

For Pattern of Blade of Plain Stripped Steel refer to page 916.

2066

doz. \$8.05
 . . . 7.10
 . . . 21.95
 . . . 21.05
 . . . 27.00
 . . . 23.80
 . . . 33.45
 . . . 9.55
 . . . 22.30
 . . . 8.50
 . . . 7.10

TURNER'S TABLE STEELS



No. 9066½, ENCORE BLADE

No. 9066	—8 inch,	Plain Stripped Steel,	“Ivorygrain” Handle	(Pattern of Handle as No. 9066½) . . .	per doz.	\$14.20
“ 9066½	—8 “	Encore “	“ “ “	“ “ “	“	20.25
“ 9067	—8 “	Plain Stripped “	“ Ivory “	(Pattern of Handle as No. 9066½) . . .	“	24.30
“ 9316	—8 “	“ “	“ “Ivorygrain” “	(Pattern of Handle as Carver No. 9316, on page 942) . . .	“	16.20
“ 9317	—8 “	“ “	“ Ivory “	(Pattern of Handle as Carver No. 9317, on page 942) . . .	“	32.40
“ 9326	—8 “	“ “	“ “Ivorygrain” “	(Pattern of Handle as Table Knife No. 9326, on page 955) . . .	“	14.20
“ 9327	—8 “	“ “	“ Ivory “	(Pattern of Handle as Table Knife No. 9327, on page 957) . . .	“	24.30



No. 9347½, ENCORE BLADE

No. 9347½	—8 inch,	Encore Steel,	Ivory Handle	per doz.	36.45
“ 9337	—8 “	Plain Stripped Steel,	Ivory Handle	(Pattern of Handle as Table Knife No. 9337, on page 957)	“	26.35



No. 9297½ and 9286½, ENCORE BLADE

No. 9297½	—8 inch,	Encore Steel,	Ivory Handle,	Sterling Silver Mounts	per doz.	42.55
“ 9286½	—8 “	“ “	“ “Ivorygrain” Handle,	Sterling Silver Mounts	“	22.30
“ 9286	—8 “	Plain Stripped Steel,	“Ivorygrain” Handle,	Sterling Silver Mounts (Pattern of Handle as No. 9286½)	“	16.20
“ 9277	—8 “	“ “	“ Ivory Handle,	Sterling Silver Mounts (Pattern of Handle as Table Knife No. 9277, page 957)	“	32.40
“ 9277½	—8 “	Encore Steel,	Ivory Handle,	Sterling Silver Mounts (Pattern of Handle as Table Knife No. 9277, page 957)	“	38.50



No. 9428½, ENCORE BLADE

No. 9428½	—8 inch,	Encore Steel,	Pearl Handle,	E. P. Mounts	per doz.	64.50
“ 9438½	—8 “	“ “	“ “	Smaller Handle	“	40.50

For Pattern of Blade of Plain Stripped Steel refer to page 946.

TABLE CUTLERY

IDEAL TABLE AND DESSERT KNIVES AND FORKS

Two-thirds size cut of Table Knives.



No. 13

No. 13—Rosewood Handle, Table Knives and Cast Forks.....	per doz.	\$2.00
" 23—Ebony " " " " " " " " " " " "	"	2.05



No. 24

No. 14—Rosewood Handle, Table Knives and Cast Forks.....	per doz.	2.05
" 14— " " " " " " " " " " " "	"	2.05
" 14— " " " " " " " " " " " "	"	1.40
" 24—Ebony " " " and Cast Forks.....	"	2.10
" 24— " " " " " " " " " " " "	"	2.10
" 24— " " " " " " " " " " " "	"	1.40

ASKHAM'S TABLE AND DESSERT KNIVES AND FORKS

Two-thirds size cuts of Table Knives.



No. 1751

No. 1751—Rosewood Handle, Table Knives and Steel Forks.....	per doz.	2.75
" 1751— " " " " " " " " " " " "	"	2.75
" 2751—Ebony " " Table " " " " " " " " " "	"	2.80
" 2751— " " " " " " " " " " " "	"	2.80
" 3751—White Bone " " Table " " " " " " " " " "	"	3.15
" 3751— " " " " " " " " " " " "	"	3.15



No. 2186

No. 1186—Rosewood Handle, Table Knives and Steel Forks.....	per doz.	3.25
" 1186— " " " " " " " " " " " "	"	3.25
" 2186—Ebony " " Table " " " " " " " " " "	"	3.35
" 2186— " " " " " " " " " " " "	"	3.35



No. 1191

No. 1191—Rosewood Handle, Table Knives and Steel Forks.....	per doz.	3.80
" 2191—Ebony " " " " " " " " " " " "	"	3.85

ASKHAM'S TABLE AND DESSERT KNIVES AND FORKS

Two-thirds size cuts of Table Knives.



No. 1902

No. 1902—Rosewood Handle, Table Knives and Steel Forks.....	per doz.	\$3.30
“ 1902—“ “ Dessert “ “ “	“	3.30
“ 2902—Ebony “ Table “ “ “	“	3.35
“ 2902—“ “ Dessert “ “ “	“	3.35
“ 3902—White Bone “ Table “ “ “	“
“ 3902—“ “ Dessert “ “ “	“



No. 1905

No. 1905—Rosewood Handle, Table Knives and Steel Forks.....	per doz.	3.70
“ 1905—“ “ Dessert “ “ “	“	3.70
“ 2905—Ebony “ Table “ “ “	“	3.75
“ 2905—“ “ Dessert “ “ “	“	3.75
“ 3905—White Bone “ Table “ “ “	“
“ 3905—“ “ Dessert “ “ “	“



No. 2762

No. 1762—Rosewood Handle, Table Knives and Steel Forks.....	per doz.	3.50
“ 1762—“ “ Dessert “ “ “	“	3.50
“ 2762—Ebony “ Table “ “ “	“	3.60
“ 2762—“ “ Dessert “ “ “	“	3.60



No. 1919

No. 1919—Rosewood Handle, Table Knives and Steel Forks.....	per doz.	4.00
“ 2919—Ebony “ “ “ “ “	“	4.10



No. 2008

No. 1008—Rosewood Handle, Table Knives and Steel Forks.....	per doz.	3.50
“ 1008—“ “ Dessert “ “ “	“	3.50
“ 2008—Ebony “ Table “ “ “	“	3.55
“ 2008—“ “ Dessert “ “ “	“	3.55



No. 2932

No. 1932—Rosewood Handle, Table Knives and Steel Forks.....	per doz.	3.45
“ 1932—“ “ Dessert “ “ “	“	3.45
“ 2932—Ebony “ Table “ “ “	“	3.50
“ 2932—“ “ Dessert “ “ “	“	3.50

ORKS

ASKHAM'S TABLE AND DESSERT KNIVES AND FORKS

Two-thirds size cuts of Table Knives.



No. 2935

No. 1935—Rosewood Handle, Table Knives and Steel Forks	per doz.	\$3.85
" 2935—Ebony " " "	"	3.90

oz. \$3.30
3.30
3.35
3.35
.....



No. 5809

No. 5809—Buffalo Horn Handle, Table Knives and Steel Forks	per doz.	5.95
" 5809— " " " Dessert " "	"	5.95

oz. 3.70
3.70
3.75
3.75
.....



No. 976. Two-thirds size cut.

No. 976—Rosewood Handle, Moits with Cast Forks	per doz.	1.95
" 977—Ebony " " "	"	1.95
" 978—White Bone " " "	"	2.10

oz. 3.50
3.50
3.60
3.60



No. 1919. Two-thirds size cut of Table Fork.

Showing style of Fork supplied with Ideal and Askham's Table Cutlery.

oz. 4.00
4.10

WILTON'S TABLE KNIVES AND FORKS

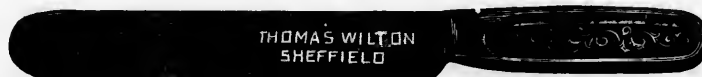

No. 8108. Half size cut.

No. 8108—Iron Handle, Table Knives and Steel Forks	per doz.	1.65
--	----------	------

oz. 3.50
3.50
3.55
3.55

oz. 3.45
3.45
3.50
3.50

JOSEPH RODGERS & SONS'

TABLE AND DESSERT KNIVES AND FORKS.

Two-thirds size cuts of Table Knives.



No. 2572

No. 2571—Rosewood Handles, Table Knives and Steel Forks.....	per doz.	\$3.85
“ 2571— “ “ Dessert “ “	“	3.80
“ 2572—Ebony “ Table “ “	“	3.85
“ 2572— “ “ Dessert “ “	“	3.80



No. 2103

No. 2103—Buffalo Horn Handle, Table Knives and Steel Forks.....	per doz.	8.50
“ 2103— “ “ “ Dessert “ “	“	6.00
“ 2103— “ “ “ Table Knives only.....	“	4.05
“ 2103— “ “ “ Dessert “ “	“	3.75



No. 2114

No. 2114—Stag Handle, Table Knives and Steel Forks.....	per doz.	6.40
“ 2114— “ “ Dessert “ “	“	5.85
“ 2114— “ “ Table Knives only.....	“	4.05
“ 2114— “ “ Dessert “ “	“	3.55

TABLE AND DESSERT KNIVES ONLY



No. 2046

No. 2046—3 $\frac{1}{2}$ inch, Ivoroide Handle, Table Knives.....	per doz.	7.45
“ 2046—3 $\frac{1}{2}$ “ “ “ Dessert “ “	“	6.00

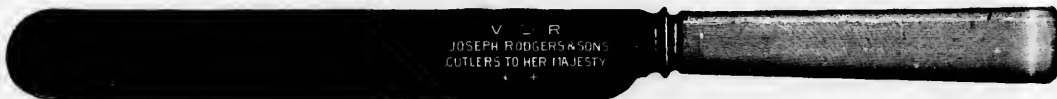

No. 2066

No. 2066—4 inch, Ivoroide Handle, Table Knives.....	per doz.	7.95
“ 2066—3 $\frac{1}{2}$ “ “ “ Dessert “ “	“	6.55

JOSEPH RODGERS & SONS'

IVORY HANDLE TABLE AND DESSERT KNIVES

To-thirds size cuts of Table Knives. *Handwritten: Best Selected*

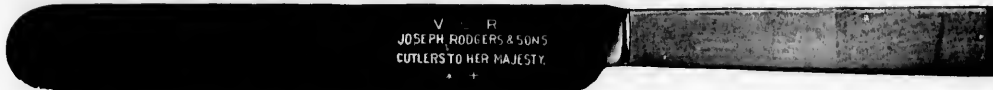

No. 2087

	No. 2087— $3\frac{1}{2}$ inch, Ivory Handle, Table Knives.....	per doz.	\$16.35
	" 2087—3 " " Dessert "	"	11.15
	" 2017— $3\frac{1}{2}$ " " Table "	"	11.90
	" 2017—3 " " Dessert "	"	10.80

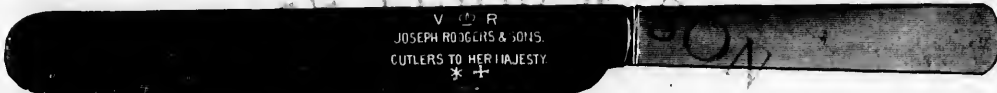

No. 2077

	No. 2077— $3\frac{1}{2}$ inch, Ivory Handle, Table Knives.....	per doz.	16.95
	" 2077—3 " " Dessert "	"	11.15
	" 2027— $3\frac{1}{2}$ " " Table "	"	11.90
	" 2027—3 " " Dessert "	"	10.80

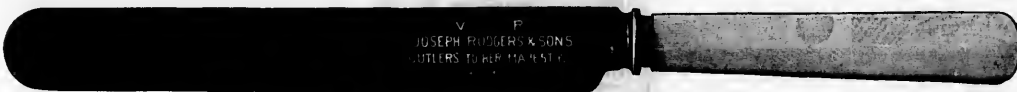

No. 2097

	No. 2097— $3\frac{1}{2}$ inch, Ivory Handle (Flat, Round End), Table Knives.....	per doz.	17.45
	" 2097—3 " " Dessert "	"	12.25
	" 2097 $\frac{1}{2}$ — $3\frac{1}{2}$ " " Table " Silver Plated Blades.....	"	20.80
	" 2097 $\frac{1}{2}$ —3 " " Dessert " " "	"	13.75

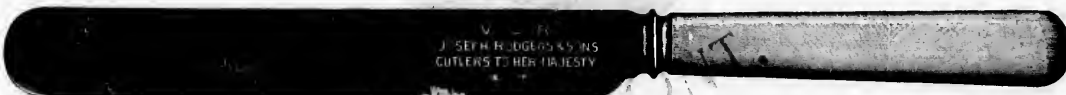

No. 2067

	No. 2067—4 inch, Ivory Handle, Table Knives.....	per doz.	25.25
	" 2067— $3\frac{1}{2}$ " " Dessert "	"	19.10
	" 2067 $\frac{1}{2}$ —4 " " Table " Silver-Plated Blades.....	"	28.00
	" 2067 $\frac{1}{2}$ — $3\frac{1}{2}$ " " Dessert " " "	"	21.55
	" 2057—4 " " Table "	"	19.70
	" 2057— $3\frac{1}{2}$ " " Dessert "	"	13.00

All numbers except 2017, 2027, and 2057, are Best Selected Ivory.

GEORGE WOSTENHOLM & SONS' TABLE AND DESSERT KNIVES

	No. 5036— $3\frac{1}{2}$ inch, Ivoroide Handle, Table Knives (Pattern as No. 8036, page 954).....	per doz.	\$7.60
	" 5036— $3\frac{1}{2}$ " " Dessert " " " 8036, " 954.....	"	6.10
	" 5046—3 " " Table " " " 8046, " 954.....	"	7.00
	" 5046— $3\frac{1}{2}$ " " Dessert " " " 8046, " 954.....	"	6.10
	" 5066—4 " " Table " " " 2066, " 952.....	"	8.10
	" 5066— $3\frac{1}{2}$ " " Dessert " " " 2066, " 952.....	"	6.70

COLLINGS & WALLIS'

IVOROIDE HANDLE TABLE AND DESSERT KNIVES

Two-thirds size cuts of Table Knives.

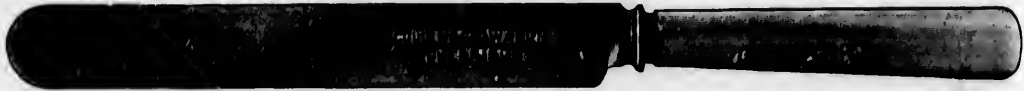

No. 8006

No. 8006	-3 1/4 inch, Ivoroide Handle, Table Knives.....	per doz.	\$4.30
	" 8006 -3 1/4 " " " " Dessert "	"	3.00

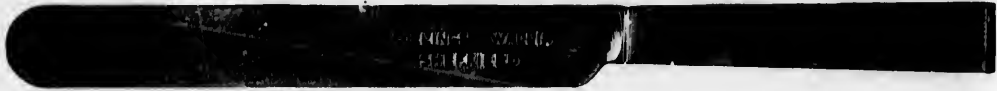

No. 8046

No. 8046	-3 1/4 inch, Ivoroide Handle, Table Knives.....	per doz.	4.30
	" 8046 -3 1/4 " " " " Dessert "	"	3.00
	" 8046 -3 1/4 " " " " Table "	"	6.00
	" 8046 -3 1/4 " " " " Dessert "	"	4.50



No. 8036

No. 8036	-3 1/4 inch, Ivoroide Handle, Table Knives.....	per doz.	6.00
	" 8036 -3 1/4 " " " " Dessert "	"	4.50

THOMAS TURNER & CO'S

"IVORYGRAIN" HANDLE TABLE AND DESSERT KNIVES

Half size cuts of Table Knives.



No. 8076

No. 8076	-3 1/4 inch, "Ivorygrain" Handle, Table Knives.....	per doz.	6.25
	" 8076 -3 1/4 " " " " Dessert "	"	5.50
	" 8076 1/2 -3 1/4 " " " " " Silver-Plated Blades.....	"	8.10



No. 8086

No. 8086	-3 1/4 inch, "Ivorygrain" Handle, Table Knives.....	per doz.	6.25
	" 8086 -3 1/4 " " " " Dessert "	"	5.50
	" 8086 1/2 -3 1/4 " " " " " Silver-Plated Blades.....	"	8.10



No. 8066

No. 8066	-4 inch, "Ivorygrain" Handle, Table Knives.....	per doz.	8.45
	" 8066 -3 1/4 " " " " Dessert "	"	7.05
	" 8066 1/2 -3 1/4 " " " " " Silver-Plated Blades.....	"	9.80

TURNER'S TABLE AND DESSERT KNIVES

Half size cuts of Table Knives.



No. 9246

No. 9246	—4½ inch, "Ivorygrain" Handle, Table Knives	per doz.	\$8.45
" 9246	—3½ " " " " Dessert	"	7.05
" 9246	—3½ " " " " Silver-Plated Blades	"	9.80



No. 9256. Two-thirds size cut of Table Knife.

No. 9256	—4½ inch, "Ivorygrain" Handle, Table Knives	per doz.	8.45
" 9256	—3½ " " " " Dessert	"	7.05



No. 9326

No. 9326	—4 inch, "Ivorygrain" Handle, Table Knives	per doz.	8.45
" 9326	—3½ " " " " Dessert	"	7.05



No. 9316

No. 9316	—4½ inch, "Ivorygrain" Handle, Table Knives	per doz.	10.80
" 9316	—3½ " " " " Dessert	"	8.10



No. 9266

No. 9266	—4½ inch, "Ivorygrain" Handle, Sterling Silver Ferrule, Table Knives	per doz.	11.85
" 9266	—4 " " " " Dessert	"	10.15



No. 9286

No. 9286	—4½ inch "Ivorygrain" Handle, Sterling Silver Ferrule, Table Knives	per doz.	9.80
" 9286	—3½ " " " " Dessert	"	8.45

TURNER'S TABLE AND DESSERT KNIVES

Half size cuts of Table Knives.



No. 9238

No. 9238—5½ inch, "Ivorygrain" Handle, E. P. Mounts, Table Knives.....	per doz.	\$22.30
" 9238—4½ " " " " Dessert "	"	19.00

TURNER'S IVORY HANDLE TABLE AND DESSERT KNIVES.



No. 9067

No. 9067—4 inch, Ivory Handle, Table Knives.....	per doz.	16.55
" 9067—3½ " " " Dessert "	"	13.20



No. 9247

No. 9247—4½ inch, Ivory Handle, Table Knives.....	per doz.	17.25
" 9247—3½ " " " Dessert "	"	13.50



No. 9317

No. 9317—4½ inch, Ivory Handle, Table Knives.....	per doz.	25.05
" 9317—3½ " " " Dessert "	"	18.25
" 9307—4 " " " Table "	"	16.20
" 9307—3½ " " " Dessert "	"	13.00



No. 9347

No. 9347—4½ inch, Ivory Handle, Through Tang, Table Knives.....	per doz.	23.05
" 9347—3½ " " " Dessert "	"	17.55

TURNER'S TABLE AND DESSERT KNIVES

Two-thirds size cuts of Table Knives.



No. 9257

No. 9257—4½ inch, Ivory Handle, Table Knives per doz. \$17.25
 " 9257—3¾ " " " Dessert " " 13.50



No. 9337

No. 9337—4½ inch, Ivory Handle, Table Knives per doz. 19.00
 " 9337—3¾ " " " Dessert " " 10.20



No. 9327

No. 9327—4 inch, Ivory Handle, Table Knives per doz. 18.00
 " 9327—3¾ " " " Dessert " " 15.55

Half size cuts of Table Knives.



No. 9277

No. 9277—4½ inch, Ivory Handle, Sterling Silver Ferrule, Table Knives per doz. 22.30
 " 9277—3¾ " " " " Dessert " " 18.25



No. 9297

No. 9297—4½ inch, Ivory Handle, Sterling Silver Ferrule, Table Knives per doz. 22.30
 " 9297—3¾ " " " " Dessert " " 18.25

CUTLERY CABINETS

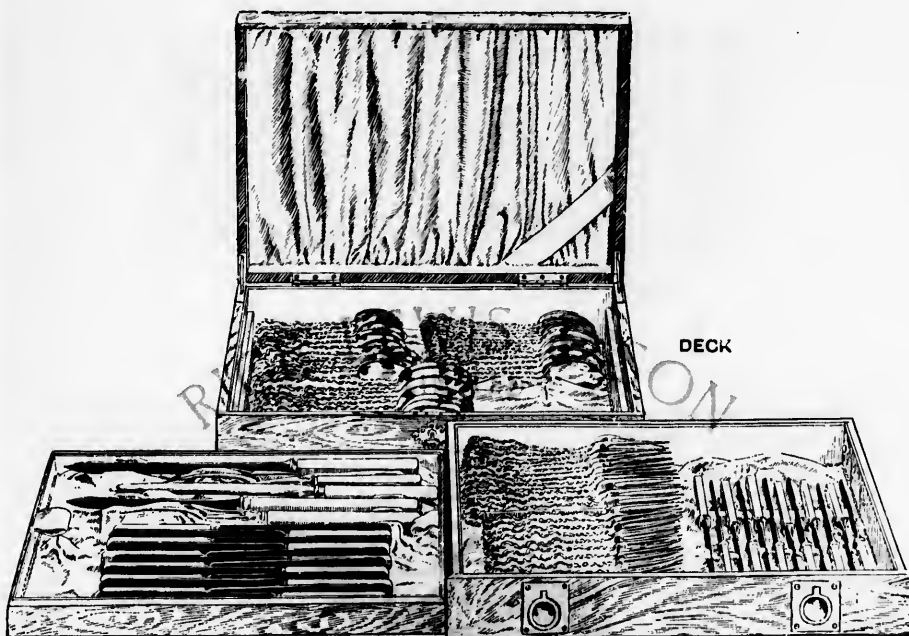

TRAY

No. A

DRAWER

DECK AND TRAY

No. A—Size 15½ x 12½ x 4 inches inside.

Fitted for

12 Table Spoons.	12 Tea Spoons.	12 Dessert Forks.	12 Dessert Knives.
12 Dessert " "	12 Coffee " "	12 Medium " "	12 Table " "

Price, Natural Finished Wood, Satin Lined. (Cabinet only) each \$22.00

DECK AND DRAWER

No. B—Size 15½ x 12½ x 4 inches inside.

Fitted for

12 Table Spoons.	12 Tea Spoons.	12 Dessert Forks.	12 Dessert Knives.
12 Dessert " "	12 Coffee " "	12 Medium " "	12 Table " "

Price, Natural Finished Wood, Satin Lined. (Cabinet only) each 24.00

DECK, TRAY AND DRAWER

No. C—Size 15½ x 12½ x 6½ inches inside.

Fitted for

1 Pair Carvers.	12 Dessert Knives.	12 Coffee Spoons.	12 Dessert Forks.
1 " Game Carvers.	1 Sugar Shell.	12 Tea " "	12 Medium " "
1 Steel.	1 Butter Knife.	12 Dessert " "	1 Mustard Spoon.
12 Medium Knives.	2 Salt Spoons.	12 Table " "	

Price, Natural Finished Wood, Satin Lined. (Cabinet only) each 30.00

Oak Usually Kept in Stock.

doz. \$52.65
32.40

doz. 29.70
19.00

doz. 32.40

Case, Oval
e Ta-
dessert
meat
game
dozen
dozen
rks.
..... \$65.00

Oak
dozen
iddle
dozen
pair
pair
teel,
table
Des-
case 45.00

pat-
with
con-
val
ugh
s, 1
s, 1
pair
core
oste,
E. P.
zen
case 100.00

CUTLERY CABINETS



DECK AND ONE DRAWER

No. D—Size 16½ x 15½ x 8, inside.

Fitted for:

12 Table Knives.	12 Table Spoons.	1 Mustard Spoon.	1 Cream Ladle.
12 Dessert “	12 Dessert “	1 Sugar “	1 Soup “
12 Table Forks.	12 Tea “	1 Sugar Tong.	
12 Dessert “	2 Salt “	1 Butter Knife.	

Price, Natural Finished Wood, Satin Lined.....(Cabinet only) each \$34.00



DECK AND TWO DRAWERS

No. E—Size 22 x 16 x 10 inch, inside.

Fitted for:

1 Pair Carvers.	12 Dessert Knives.	12 Coffee Spoons.	1 Gravy Ladle.
1 “ Game Carvers.	12 Table Forks.	2 Salt “	2 Soup Ladles.
1 Steel.	12 Dessert “	1 Mustard Spoon.	2 Nut Crackers.
1 Pair Fish Carvers.	12 Table Spoons.	1 Sugar “	12 Nut Picks.
1 Bread Knife.	12 Dessert “	1 Sugar Tong.	
12 Table Knives.	12 Tea “	1 Cheese Scoop.	

Price, Natural Finished Wood, Satin Lined.....(Cabinet only) each 58.00

No. 393
 “ 393
 “ 396
 “ 396

No. 12
 “ 12
 “ 12
 “ 12
 “ 391
 “ 391
 “ 112
 “ 112

No. 212
 “ 212

SILVER-PLATED KNIVES AND FORKS



WINDSOR PATTERN

Knives Only.

No. 393—T.S.P., Windsor Pattern, Silver-Plated Table Knives only, 12 dwt.....	per doz.	\$6.00
" 393— " " " " Dessert " 12 "	"	6.00
" 398— " " " " Table " 16 "	"	8.00
" 396— " " " " Dessert " 16 "	"	8.00

RICE LEWIS & SON
LIMITED



No. 12, ROUND END

No. 12—Rogers Bros'., Round End, Silver-Plated Table Knives and Forks, 12 dwt. (6 Knives and 6 Forks) ..	Per set.	7.50
" 12— " " " " Dessert " 12 " " " ..		7.50
" 12— " " " " Table Knives only, 12 dwt.....	Per doz.	7.00
" 12— " " " " Dessert " 12 "		7.00
" 391—T.S.P., Square End, Silver-Plated Table Knives only, 12 dwt.....		6.00
" 391— " " " " Dessert " 12 "		6.00
" 112—Sheffield, " " Table " "		2.20
" 112— " " " " Dessert " "		2.20

TORONTO, ONT.



SHELL PATTERN

No. 212—Shell Pattern, Rogers Bros'., Silver-Plated Table Knives and Forks, 12 dwt. (6 Knives and 6 Forks) ..	Per set.	8.50
" 212— " " " " Dessert " " 12 " " " ..		7.80

CHILD'S SETS



No. 1894



RICHMOND

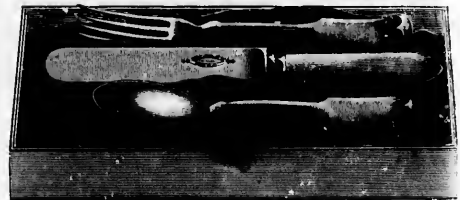

No. 192

No. 1894—Steel, Tin-Plated and Burnished.....	per doz. sets	\$2 (3)
Richmond, " Silver-Plated	" "	4.00
No. 192—Tipped, Roger Bros., Silver-Plated, 12 dwt.....	per set	2 1/2

No. 967

No. 968

No. 969

No. 970

No. 971

" 971

No. 972

" 972

" 972

TURNER'S DESSERT KNIVES AND FORKS

Two-thirds size cuts.



No. 9676

No. 9676—"Ivorygrain" Handle, Steel Blades, Silver-Plated, not in case.....per doz. \$16.25



No. 9686

No. 9686—"Ivorygrain" Handle, Steel Blades, Silver-Plated, in Walnut Case, 12 pairs.....per case 23.75



No. 9696

No. 9696—"Ivorygrain" Handle, Nickel Blades, Silver-Plated, not in case.....per doz. 24.50



No. 9707

No. 9707—Ivory Handle, Nickel Blades, Silver-Plated, E. P. Ferrules, in Walnut Case, 12 pairs...per case 37.50



No. 9717

No. 9717—Ivory Handle, Nickel Blades, Silver-Plated, E. P. Ferrules, in Walnut Case, 6 pairs....per case 24 00
 " 9717—" " " " " " " 12 " " 43.00



Nos. 9726 and 9728

No. 9726—"Ivorygrain" Handle, Nickel Blades, Silver-Plated, E. P. Ferrules, in Walnut Case, 12 pairs, per case 36.50
 " 9726—Pearl " " " " " " 12 " " 43.00
 " 9728—" " " " " " not in case.....per doz. 36.50

sets \$2.00
 4.00
 set 2.10

TURNER'S DESSERT KNIVES AND FORKS

Two-thirds size cuts.



No. 9738

No. 9738—Pearl Handle, Nickel Blades, Silver-Plated, E. P. Ferrules, not in case per doz. \$43.00



No. 9748

No. 9748—Pearl Handle, Nickel Blades, Silver-Plated, E. P. Ferrules, in Walnut Case, 12 pairs... per case 46.00

TURNER'S FISH KNIVES AND FORKS

Two-thirds size cuts.



No. 9426

No. 9426—"Ivorygrain" Handles, Nickel Blades, Silver-Plated, E. P. Ferrules, in Walnut Case, 6 pairs, per case 23.65
 " 9426—"Ivorygrain" Handles, Nickel Blades, Silver-Plated, E. P. Ferrules, in Walnut Case, 12 pairs, per case 43.00
 " 9426—"Ivorygrain" Handles, Nickel Blades, Silver-Plated, E. P. Ferrules, not in case..... per doz. 31.75



No. 9436

No. 9436—"Ivorygrain" Handles, Nickel Blades, Silver-Plated, not in case..... per doz. 20.35

TURNER'S FISH KNIVES AND FORKS

Two-thirds size cuts.



No. 9446

No. 9446—"Ivorygrain" Handles, Nickel Blades, Silver-Plated, not in Case.....per doz. \$28.35

RICE LEWIS & SON
LIMITED



Nos. 9466 and 9476

No. 9466—"Ivorygrain" Handles, Nickel Blades, Silver-Plated, in Walnut Case, 12 pairs.....per case 31.80

" 9476—"Ivorygrain" Handles, Nickel Blades, Silver-Plated, in Walnut Case, 6 pairs and one pair Fish Carvers.....per case 25.25

TORONTO, ONT.



No. 9478

No. 9478—Pearl Handles, Nickel Blades, Silver-Plated, E. P. Ferrules, not in case.....per doz. 45.00

doz. \$43.00

case 40.00

pairs, 23.65

pairs, 43.90

doz. 31.75

doz. 25.35

FISH CARVERS IN CASES

One-quarter size cuts.

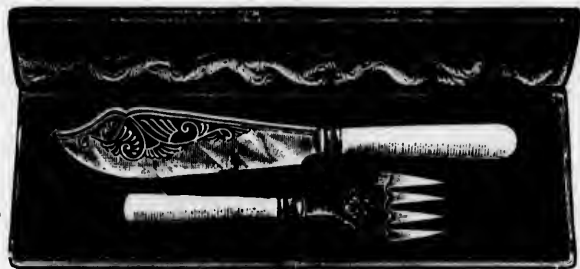

No. 9626

No. 9626—“Ivorygrain” Handles, Nickel Blades, Silver-Plated, in Leather Case.....	per case	\$8.10
“ 9626—“ “ “ “ “ “ not in case.....	per pair	0.10

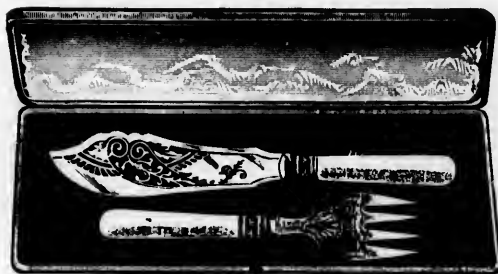

No. 9637



No. 9638

No. 9637—Ivory Handles, Nickel Blades, Silver-Plated, E. P. Ferrules, in Leather Case.....	per case	9.75
“ 9637—“ “ “ “ “ “ not in case.....	per pair	7.75
“ 9638—Pearl Handles, “ “ “ “ “ “ in Leather Case.....	per case	13.50



No. 9648

No. 9648—Pearl Handles, Nickel Blades, Silver-Plated, E. P. Ferrules, in Leather Case.....	per case	18.00
--	----------	-------

TURNER'S FRUIT KNIVES

Two-thirds size cuts.



No. 928

No. 928—Pearl Handle, Steel Blade, Silver-Plated, E.P. Ferrule per doz. \$10.80
 " 938— " " " " Sterling Silver Ferrule..... " 12.15



No. 948

No. 948—Pearl Handle, Steel Blade, Silver-Plated, E.P. Ferrule..... per doz. 12.15



No. 950

No. 950—Sterling Silver Handle, Steel Blade, Silver Plated..... per doz. 18.90
 " 980—Pattern as No. 950, 6 Knives, 6 E.P. Coffee Spoons, and 1 E.P. Sugar Tongs, in Leather Case..... per case. 18.90

TURNER'S LEMON KNIVES



No. 971

No. 971—Boxwood Handle, Silver-Plated Blade..... per doz. 10.15



No. 980

No. 980—E.P. Nickel Handle, Silver-Plated Blade..... per doz. 24.30



No. 992

No. 992—Ebony Handle, Silver-Plated Blade, E.P. Ferrule per doz. 10.15



No. 998

No. 998—Pearl Handle, Silver-Plated Blade, Sterling Silver Ferrule..... per doz. 32.40

case \$8.10
 pair 6.10

case 9.75
 pair 7.75
 case 13.50

case 18.60

TURNER'S BUTTER KNIVES

Two-thirds size cuts.



No. 9106

No. 9106—"Ivory grain" Handle, Nickel Blade, Silver-Plated per doz. \$12.15



No. 9116

No. 9116—"Ivory grain" Handle, Nickel Blade, Silver-Plated..... per doz. 12.15



No. 9128

No. 9128—Pearl Handle, Nickel Blade, Silver-Plated, Sterling Silver Ferrule..... per doz. 16.20



No. 9138

No. 9138—Pearl Handle, Nickel Blade, Silver-Plated, E. P. Ferrule..... per doz. 18.25



No. 9148

No. 9148—Pearl Handle, Nickel Blade, Silver-Plated, Sterling Silver Ferrule..... per doz. 24.30



No. 9158

No. 9158—Pearl Handle, Nickel Blade, Silver-Plated, E. P. Ferrule..... per doz. 24.30

BUTTER KNIVES



No. 30j. Half size cut.

No. 30j - Nevada Silver.....per doz. \$2.00



"BERKSHIRE"
Full size cut.



No. 9160. Two-thirds size cut.

No. 9160 - Turner's, Sterling Silver Handle, Nickel Blade, Silver-Plated.....per doz. 24.30
 " 12 - 1847 Rogers Bros., A1 Quality, Silver-Plated.....per doz. 9.00
 " Berkshire," 1847 Rogers Bros., A1 Quality, Silver-Plated.....per doz. 12.00

TURNER'S CHEESE SCOOPS



No. 2430. Two-thirds size cut.

No. 2430 - "Ivorygrain" Handle, Steel Blade, Silver-Plated.....per doz. \$21.00

doz. \$12.15

doz. 12.15

doz. 16.20

doz. 18.25

doz. 24.30

doz. 24.30

RICE LE... & SON

TORONTO, ONT.

THOMAS TURNER & CO.'S

NUT CRACKS

Two-thirds size cuts.

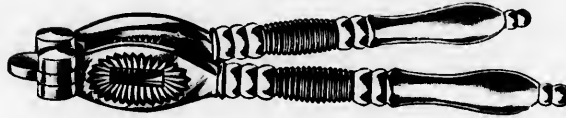

No. 951

No. 951—Steel, Silver-Plated.....per doz. \$18.25



No. 498

No. 498—Steel, Silver-Plated.....per doz. 15.00

NUT PICKS



No. 2453

2453—Pearl Handle, Silver-Plated Blade and Ferruleper doz. 11.00

GRAPE SCISSORS

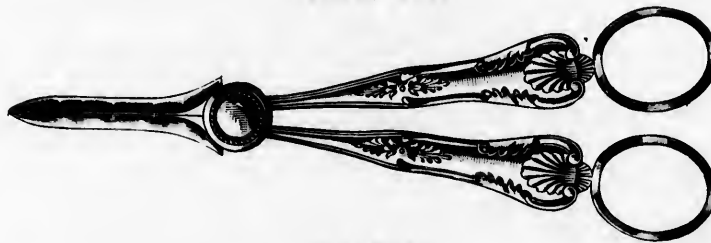

"King's Pattern"

Grape Scissors, Steel Blades, Nickel Handles, Silver-Plated, in King's, Queen's, Princess and Old English Patternsper pair 5.25

SARDINE FORKS

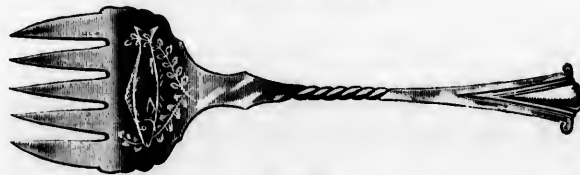

No. 660

No. 660—Nickel, Silver-Platedper doz. 10.25

THOMAS TURNER & CO.'S

SALAD SERVERS

Five-eighths size cuts.



No. 1160

No. 1160—Nickel, Silver-Plated.....per pair \$5.05

JAM SPOONS



No. 578½. Two-thirds size cut.

No. 578½—Nickel, Silver-Plated.....per doz. 10.20



No. 527. Two-thirds size cut.

No. 527—Nickel, Silver-Plated.....per doz. 16.20

SUGAR SPOONS



No. 854. Two-thirds size cut.

No. 854—Nickel, Silver-Plated.....per doz. 24.30

TURNER'S SUGAR TONGS

Two-thirds size cuts.



No. 1047

No. 1047—Nickel, Silver-Plated..... per doz. \$11.35



No. 1155

No. 1155—Nickel, Silver-Plated..... per doz. 17.00

LADLES



TRIUMPH GRAVY LADLE. Half size cut.

Full Length	CREAM	GRAVY	OYSTER	MEDIUM	SOUP
T. S. P., Triumph Pattern, Extra Plate..... per doz.	5¾	7	9½	10½	11¼ inch.
T. S. P., Tipped " "	\$16.20	21.00	46.80	57.00	61.20
	16.20	21.00	46.80	57.00	61.20

PIE KNIFE



Half size cut.

T. S. P., Extra Plate, Triumph Pattern, Satin or Figured Blade..... per doz. 50.40

CRUMB KNIFE



Half size cut.

T. S. P., Extra Plate, Triumph Pattern, Satin or Plain Blade..... per doz. 57.00

No. 35
 " 35
 " 15
 " 17
 No. 90
 " 20
 No. 9

Length
 Per G

TINNED SPOONS



No. 153



Nos. 170 and 352.



No. 350½

No. 350½—Tinned Steel Tea Spoons.....		per gross	\$1.00
" 352 — " "		"	2.30
" 153 — " Table Spoons		"	3.40
" 170 — " Heavy		"	4.70



Nos. 900 and 200

	Tea Spoons	Dessert Forks	Dessert Spoons	Table Forks	Table Spoons
No. 900—Tinned Steel..... per gross	\$3.65	8.50	7.15	9.20	7.15
" 200— " Heavier "	5.50	11.85	11.00

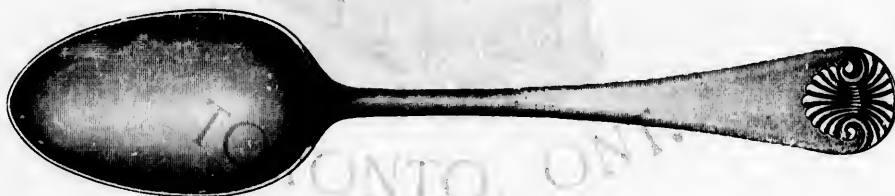

No. 950

No. 950—Tinned Steel..... per gross		Tea Spoons	Table Spoons
		\$4.00	7.00

TINNED BASTING SPOONS



Length.....	10	12	14	16 inch.
Per Gross.....	\$6.00	7.25	8.05	10.25

NEVADA SILVER SPOONS AND FORKS

Warranted to Wear White Throughout.



"OVAL"

Nos.....	305	304	303	302	301	300
	Tea Spoons	Tea Spoons	Dessert Forks	Dessert Spoons	Table Forks	Table Spoons
	Medium.	Large.				
Per dozen	\$1.45	1.70	2.00	2.00	3.75	3.75

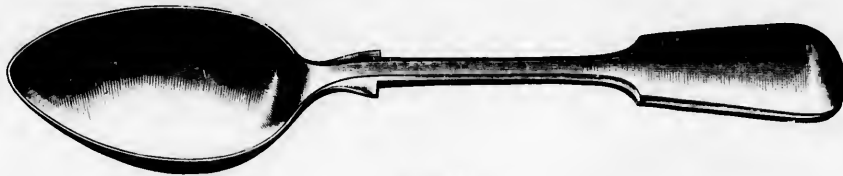

"FIDDLE"

LIGHT FIDDLE

Nos.....	360	359	358	357	356	355
	Tea Spoons	Tea Spoons	Dessert Forks	Dessert Spoons	Table Forks	Table Spoons
	Large.	Medium.				
Per dozen	\$1.05	1.10	2.55	2.55	3.40	3.40

HEAVY FIDDLE

Nos.....	345	344	343	342	341	340
	Tea Spoons	Tea Spoons	Dessert Forks	Dessert Spoons	Table Forks	Table Spoons
	Large.	Medium.				
Per dozen	\$1.50	1.70	3.25	3.25	4.45	4.45



"LAUREL"

Nos.....	2227	2233	2226	2225	2224	2223	2222
	Tea Spoons	Tea Spoons	Tea Spoons	Dessert Forks	Dessert Spoons	Table Forks	Table Spoons
	Small.	Medium.	Large.				
Per dozen ...	\$1.30	1.45	1.50	2.75	2.75	3.60	3.60



"MAPLE"

Nos.....	375	374	373	372	371	370
	Tea Spoons	Tea Spoons	Dessert Forks	Dessert Spoons	Table Forks	Table Spoons
	Small.	Large.				
Per dozen	\$1.85	2.05	3.05	3.05	4.80	4.80

NEVADA SILVER SPOONS AND FORKS

Warranted to Wear White Throughout.



"TIPPED"

Nos.....	384	383	382	381	380
	Tea Spoons	Dessert Forks	Dessert Spoons	Table Forks	Table Spoons
Per dozen	\$1.45	2.80	2.80	3.85	3.85

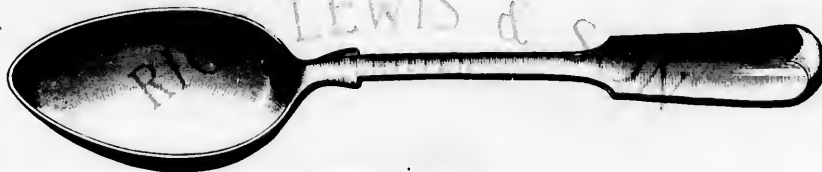

"WING TIPPED"

Nos.....	566	565	564	563	562	561	560
	Tea Spoons	Tea Spoons	Tea Spoons	Dessert Forks	Dessert Spoons	Table Forks	Table Spoons
	Small.	Medium.	Large.				
Per dozen..	\$0.85	1.05	1.15	2.35	2.35	3.00	3.00

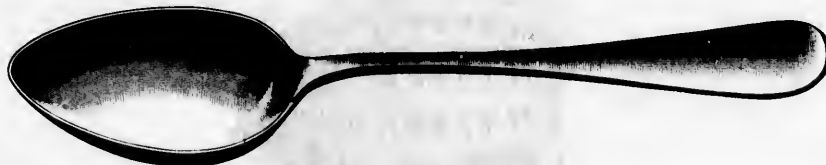

"WINDSOR"

Nos.....	526	525	524	523	522	521	520
	Tea Spoons	Tea Spoons	Tea Spoons	Dessert Forks	Dessert Spoons	Table Forks	Table Spoons
	Small.	Medium.	Large.				
Per dozen .	\$0.85	1.05	1.15	2.35	2.35	3.00	3.00

SILVER-PLATED SPOONS AND FORKS

Sterling Silver Plate on Best White Nickel Silver.



"FIDDLE"

A1 Quality.

Nos.....	244	1510	243	242	241	240
	Tea Spoons	Tea Spoons	Dessert Forks	Dessert Spoons	Table Forks	Table Spoons
	Medium.	Large.				
Per dozen	\$5.00	6.05	10.35	10.35	13.30	13.30

SILVER-PLATED SPOONS AND FORKS

Sterling Silver Plate on Best White Nickel Silver.



"MAPLE"

Al Quality.

Nos	275	274	273	272	271	270
	Tea Spoons	Tea Spoons	Dessert Forks	Dessert Spoons	Table Forks	Table Spoons
Per dozen	Small. \$5.00	Large. 5.95	10.50	10.50	13.65	13.65



"QUEEN ANNE." Two-thirds size cuts.

Al Quality.

	Afternoon or Coffee Spoons	Tea Spoons	Tea Spoons	Dessert Forks	Dessert Spoons	Table Forks	Table Spoons
Per dozen	\$6.85	Small. 7.50	Large. 7.50	13.50	15.00	17.00	18.00

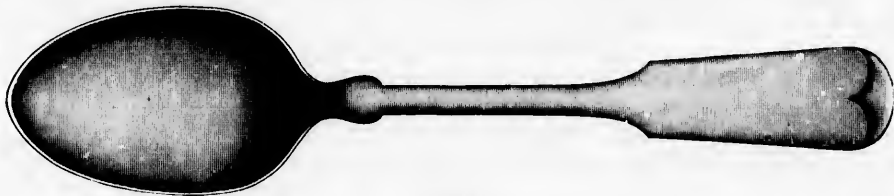

"TIPPED"

Al Quality.

	Tea Spoons	Dessert Forks	Dessert Spoons	Table Forks	Table Spoons
1847 Rogers Bros' per doz.	\$4.25	7.50	7.50	8.50	8.50
Toronto Silver Plate Co.'s. "	4.25	7.50	7.50	8.50	8.50



"PORTLAND"

Al Quality.

	Tea Spoons	Dessert Forks	Dessert Spoons	Table Forks	Table Spoons
1847 Rogers Bros' per doz.	\$4.75	8.50	8.50	9.50	9.50

SILVER-PLATED SPOONS AND FORKS

Sterling Silver Plate on Best White Metal Silver.



"BERKSHIRE"

All Quality.

	Tea Spoons	Dessert Forks	Dessert Spoons	Table Forks	Table Spoons
1847 Rogers Bros. per doz.	\$4.75	8.50	8.50	9.50	9.50

RICE, LEWIS & SON
LIMITED

STERLING SILVER SPOONS AND FORKS



"TIPPED"

Approximate Weight per dozen Pieces.

Tea Spoons	Dessert Spoons	Table Spoons	Dessert Forks	Table Forks
6 and 8 ounces.	16 ounces.	22 ounces.	16 ounces.	22 ounces.
Price..... per ounce \$...				

TORONTO, ONT.



"LOUIS XV"

Approximate Weight per dozen Pieces.

Tea Spoons	Dessert Spoons	Table Spoons	Dessert Forks	Table Forks
6, 8½ and 10 ounces.	17 ounces.	24 ounces.	17 ounces.	24 ounces.
Price..... per ounce \$...				

COFFEE SPOONS



1847 Rogers Bros.' Coffee Spoons, All Quality per doz. \$6.00

Imitati

Imitati

No. 010-

No. 3-T

CORDOVA
SAVOY
RUBY
COLUMBIA
MAJESTIC

NOV 20
100000
MUZZLE LOADING GUNS



SINGLE BARREL

Imitation Twist Barrel, Back Action Lockeach \$3.00

RICE LEWIS & SON
DOUBLE BARREL

Imitation Twist Barrels, Back Action Lockseach 6.00

SINGLE BREECH LOADING SHOT GUNS



TORONTO, ONT.
No. 010—Top Action Nickel Mountings, Pat. Fore End, Walnut Stock, Pistol Grip, 12 Bore, Plain Barrel ..each 10.80

REMINGTON SINGLE BREECH LOADING GUNS



No. 3—Top Lever, Blued Steel Barrel, Rebounding Lock, Side Cocking Lever, Pistol Grip, Choke Bore, 12 or 16 Bore.....each 13.25

doz. \$6.00

BREECH LOADING GUNS



ZULU

Zulu Single Breech Loading Guns, 12 Bore.....each \$6.00

BREECH LOADING DOUBLE BARREL GUNS

LEFAUCHEUX SYSTEM



No. 51—Blued Barrels, Lefauchaux System, Back Action Locks, Oiled Walnut Stock, Checkered Grip, Case Hardened Mountings, 12 Gauge, 30 and 32 inch Barrels, Weight 7 to 9½ lbs.,.....each 8.00



TOP SNAP ACTION

No. A—Fine Imitation Twist, Rebounding Locks, Pistol Grip, Checkered, 12 Bore.....each 11.00
 " B-- " " " " " " Matted Rib, Engraved, 12 and 16 Bore. " 11.50

No. C
 " O
 " D
 " D
 " J
 " J

No. E
 " L
 " L

DOUBLE BARREL BREECH LOADING GUNS



RICE LEWIS & SON
LIMITED
GENUINE BAR LOCKS, EXTENSION RIBS

No. C—Fine Imitation Twist, Rebounding Locks, Pistol Grip, Checkered Butt, 12 Bore.....	each	\$12.75
“ O— “ “ “ “ “ “ “ “ 10	“	13.25
“ D—Imitation Boston Damascus, Rebounding Locks, Pistol Grip, Checkered Butt, Double Bolt, Matted Rib, 12 Bore.....	each	14.25
“ D—Imitation Boston Damascus, Rebounding Locks, Pistol Grip, Checkered Butt, Double Bolt, Matted Rib, 10 Bore.....	each	15.00
“ J—Genuine Twist, Rebounding Locks, Deeley & Edge Fore End, Matted Rib, Fine Engraving, Full Pistol Grip with Plate, Extra Fine Polished Barrels, Left Barrel Choked, 12 and 16 Bore..	each	17.25
“ J—The same, 10 Bore	“	18.00



No. E—Imitation Fine Damascus, Full Pistol Grip with Shield, Greener Bolt, Deeley & Edge Fore End, Matted Rib, 12 Bore.....	each	17.75
“ L—Boston Damascus Barrels, Best Quality Bar Lock, Rubber Butt, Rebounding Lock, Pistol Grip, Greener Bolt, 12 Bore	each	25.25
“ L—The same, 10 Bore	“	23.00

HAMMERLESS GUNS

- 01097



No. 001—Hammerless Guns, Machine Made, Twist Barrels, 12 Bore..... each \$29.00
 " 002— " " " " Damascus Barrels, 12 Bore..... " 33.00

11090

WINCHESTER MAGAZINE SHOT GUNS



Repeater, 12 Bore, very Rapid Firing Gun, Rolled Steel Barrel.....each 25.00
 " " " " " " " " Take Down..... " 27.00

NE 5090

REMINGTON HIGH GRADE GUNS



No. 1—Decarbonized Steel Barrels, Rebounding Low Circular Hammers, Pistol Grip, Extension Matted Rib, Double Bolt, Block Striker, Deeley & Edge Fore End, Checkered Grip and Fore End, Rubber Butt, Left Choke, Right Modified, 12 Bore.....each 40.00
 " 2—Same style Gun as No. 1, but has Fine Twist Steel Barrels, 12 Bore..... " 45.00

No. A.

No. A.

DOUBLE BARREL BREECH LOADING GUNS

THE NEW REMINGTON HAMMERLESS

1105090



No. A.R.—Two Stripe Damascus Barrels, Plain Finish, Left Barrel Choke, Right Modified, English Walnut Stock, Checkered, Half Pistol Grip, Rubber Butt, Case Hardened Frame, Automatic Safety, Purdy Fore End Snap, Top Snap Extension, Flat Matted Rib with Bite, 12 Bore..... each \$64.00



No. A.E.R.—Two Stripe Damascus Barrels, Triple Bolt, Top Snap, Extension Matted Rib, English Walnut Stock, Half Pistol Grip, Rubber Butt Plate, Checkered Fore End, Purdy Fore End Snap, Independent Automatic Shell Ejector, 12 Bore each 75.00

ch \$29.00
" 33.00

ch 25.00
" 27.00

sted
nd,
ach 40.00
" 45.00

DOUBLE BARREL BREECH LOADING GUNS

CLABROUGH & JOHNSTONE

Handwritten: No. 632



No. 632

- No. 631—Finest English Twist Barrels, Cross Bolt Action, Left Choke, Engine Turned Rib, Deeley & Edge Fore End, Rebounding Locks, Horn Heel Plate, Neatly Engraved. 12 and 16 Bore.....each \$30.50
 " 632—Same as 631, but without Cross Bolt Action, complete Gun, 12 Bore..... " 28.00
 " 632— " " " " " " " 10 " " 28.50



No. 629

- No. 628—Damascus Barrels, Cross Bolt Action, Flat Engine Turned Rib, Deeley & Edge Snap Fore End, Rebounding Locks, Walnut Stock, Horn Heel Plate, Left Choke, 12 Boreeach 33.75
 " 629—Special Value Gun, Cross Bolt Action, Fine Steel Barrels, Left Choke, Flat Engine Turned Rib, Deeley & Edge Fore End, Walnut Stock, Half Pistol Hand, Nicely Engraved and Finished, 12 Boreeach 32.00
 " 629—The same, 10 Bore..... " 34.25

PLAIN HAMMERLESS GUNS

CLABROUGH & JOHNSTONE



No. 616

These Guns are specially intended to meet the demand for a sound Hammerless Gun at a low figure, and may be thoroughly relied upon.

- No. 616—Damascus Barrels, Left Choke, Cross Bolt Action, Engine Turned Rib, Walnut Stock, Automatic Safe, Neatly Engraved and Finished, with Deeley & Edge Fore End, 12 Bore.....each \$50.00
 " 616—The same, 10 Bore " 58.50

SPECIAL HAMMERLESS GUNS



No. 615

- No. 615—Special Hammerless Gun, No. 1, Damascus Barrels, Choke, Automatic Safe, Engine Turned Rib, well selected Walnut Stock, Fine Steel Locks, 12 Bore each 61.50
 " 611—Same as above, with Ejector, 12 Bore..... " 62.50

PATENT HAMMERLESS GUNS

CLABROUGH & JOHNSTONE



No. 614

WITHOUT EJECTORS

- | | | | |
|---------|---|------|---------|
| No. 614 | —Good Quality 3 Stripe Damascus Barrels, Engine Turned Rib, Deeley & Edge Fore End, Engraved and Finished, 12 Bore..... | each | \$73.00 |
| " 615B | —Special Hammerless Gun, No. 1 Damascus Barrels, Choke, Automatic Safe, Engine Turned Rib, Walnut Stock, 12 Bore | each | 66.25 |



No. 607

WITHOUT EJECTORS

- | | | | |
|---------|--|------|-------|
| No. 607 | —Good Quality Damascus Barrels, Extension Rib, same as shown in cut No. 615, but otherwise same style as this cut, Deeley & Edge Fore End, Neatly Engraved and Finished, 12 Bore.. | each | 66.00 |
|---------|--|------|-------|

FLOBERT RIFLES

PLAIN SYSTEM



No. 3004—Hammer Breech, Side Extractor, Varnished Stock, Polished Blued Barrels, shoots B.B. or Bullet Breech Caps, Noiseless, Rifledeach \$2.75

REMINGTON SYSTEM

Rifled Barrel.



No. 3454—Remington Action, .22 Calibre, Light 22 inch Barrel, Walnut Stock, Blued Mountings, Blued Barrel, Rifled, Scroll Guard, Pistol Gripeach 3.40

WARNANT SYSTEM

Rifled Barrel.



No. 3474—Warnant Action, .22 Calibre, with Pistol Grip, Checkered, Blued Barreleach 3.50
 " 81 — " " .32 " " Checkered Pistol Grip, Heavy Barrel, Blued " 4.00

IMPROVED WARNANT ACTION

Solid Breech Block.



This Rifle, as illustrated, has Polished Blued Barrel, Rifled, Scroll Guard, Oiled Pistol Grip Stock, Full Checkered, Case Hardened Mountings, Fancy Rubber Butts, finely finished throughout.

No. 389P—In .22 Calibre, Light Barreleach \$4.00
 " 348 —In .32 " Heavy " " 4.50

STEVENS' RIFLES

THE FAVORITE



Calibres .22, .25, and .32 R. F.

.22 uses in one Rifle, the .22 C.B., .22 Short, .22 Long and .22 Long Rifle Cartridges; the .25 uses the .25 Stevens; the .32, the .32 Short and .32 Long.

No. 17—Plain Open Front and Rear Sights.....	each	\$0.30
No. 18—Beach Combination Front Sight, Open Rear and Vernier.....	"	13.20
" 19—Lyman Front, Open Rear and Lyman Peep Sights.....	"	14.00
" 20—Favorite Shotgun, same as No. 17, but Smooth Bore, for Shot Cartridges. Made for .22 and .32 Rim Fire Shot Cartridges. No other sizes are made.....	each	9.30
" 21—Bicycle Rifle, 20 inch Barrel, .22, .25 and .32 Calibre.....	each	9.30
Canvas Case to fit in Diamond Frame (for Bicycle Rifle).....	"	1.50

EXTRAS ON FAVORITE RIFLES

Fancy Walnut Stock and Fore-Arm.....	each	1.50
Barrel Part Complete, with Fore-Arm, etc., 22 inch, .22, .25 or .32 Calibre, Rifle or Shot.....	"	6.20
Rifle, with 24 inch Barrel, any Calibre, \$3.10 extra; 26 inch Barrel, \$6.20 extra. Longer barrels are not made for Favorites. Shot Barrels made 22 inches only.....	each	6.20
Breech Block, Lever and Firing Pin, complete.....	"	1.55

Every Favorite packed in a neat pasteboard box. Weight as packed in wood for shipment singly, 7 lbs.

IDEAL SPORTING AND HUNTING RIFLES



No. 44—Made in sizes, with Nos. 2 or 3 Barrels, for .22 Long Rifle R. F., .25 Stevens' R. F., and .32 Long R. F. Standard length of Barrel for Rim Fire Cartridges, 24 inches. Weight 7½ lbs.....	each	14.70
.25-20 Stevens' C. F., .25-21 Stevens' C. F., .32-40 C. F., and .38-55 C. F. Standard length of Barrel for Centre Fire Cartridges, 26 inches. Weight 7½ lbs.....	each	14.70



No. 45—With Swiss Butt Plate, Target Sight, Finely Finished, Selected Wood, otherwise same as No. 44. each	32.25
" 47—Same as No. 45, with Pistol Grip Stock.....	30.60

STEVENS' POCKET RIFLES



No. 42—Round Barrel, Globe and Peep Sights, with Detachable Shoulder Rest, Frame Nicked, Weight 1 lb., with 10 inch Barrel, for .22 Long R. F. Cartridges.....	each	11.00
--	------	-------

We can also supply any of Stevens' Pistols or Rifles not mentioned above.

REMINGTON SPORTING AND TARGET RIFLES



No. 4—Remington, Walnut Stock and Fore Arm, Rifle Butt, Octagon Steel Blue Barrels, 24½ inch, .22 Calibre. This Rifle is very accurate each \$9.30
 " 4—.32 Calibre, same as .22, only 24 inch Barrel " 9.30

WINCHESTER SINGLE SHOT RIFLES



Round Barrels, .44 - 40, .32 - 40 and .38 - 55 Calibre each 14.50
 Octagon " .44 - 40, .32 - 40 and .38 - 55 " " 15.00
 Length, .44 - 40, 26 or 28 inches; .32 - 40 and .38 - 55, 26 to 30 inches. Quotation given on special Rifles.

WINCHESTER REPEATING RIFLES

MODEL 1890



A Two-part Gun, can be packed in a Victoria case. This gun can be furnished to use the .22 Short, .22 Long or .22 Winchester Rim Fire Cartridges each 16.00

SPORTING RIFLE, MODEL 1892



.32, .38 and .44 Calibre.

24 inch Round Barrel, Full Magazine, Plain Trigger, Weight about 6½ lbs., Number of Shots, 15 each 18.00
 24 " Octagon " " " " 6½ " " " 15 " 19.50

SPORTING RIFLE, MODEL 1894

.32 - 40 and .38 - 55 Calibre,

28 inch Round Barrel, Full Magazine, 10 Shots, Weight 7½ lbs. each 18.00
 26 " Octagon " " " " 7½ " " " " 19.50

SPORTING RIFLE, MODEL 1886

.45 - 70, .45 - 90, .40 - 70, .40 - 82, .40 - 65, and .38 - 56 Calibre.

26 inch Round Barrel each 19.50
 26 " Octagon " " 21.00

MARLIN SAFETY REPEATING RIFLES

MODEL 1892



.22 Calibre, Rim Fire.

24 inch, Round Barrels, Full Magazine, Plain Trigger, 6 lbs.....	each	\$18.00
24 " Octagon " " " " " 5 1/2 "	"	19.50

Magazine holds 25 Cartridges .22 Short, 20 Cartridges .22 long, 18 Cartridges .22 Long Rifle.

.32 Calibre Rim or Centre Fire.

24 inch, Round Barrels, Full Magazine, Plain Trigger, 6 1/2 lbs.....	each	18.00
24 " Octagon " " " " " 8 "	"	19.50

Magazine holds 18 Cartridges .32 Short, 15 Cartridges .32 Long.

MODEL 1894



.38-40 and .44-40 Calibre.

24 inch, Round Barrels, Full Magazine, 14 Shot, Plain Trigger, 7 1/2 lbs.....	each	18.00
24 " Octagon " " " " " 14 " " " 6 3/4 "	"	19.50

MODEL 1893

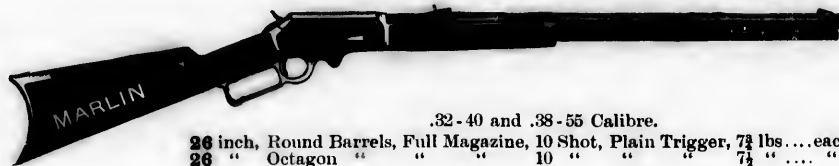

.32-40 and .38-55 Calibre.

26 inch, Round Barrels, Full Magazine, 10 Shot, Plain Trigger, 7 1/2 lbs....	each	19.50
26 " Octagon " " " " " 10 " " " 7 1/2 "	"	21.00

MODEL 1895

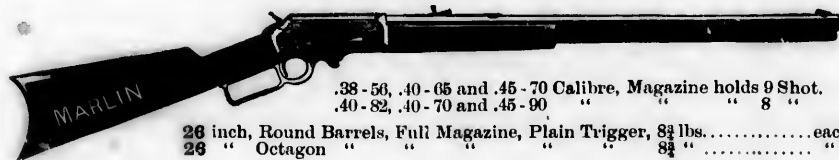

.38-56, .40-65 and .45-70 Calibre, Magazine holds 9 Shot.
.40-82, .40-70 and .45-90 " " " " 8 " "

26 inch, Round Barrels, Full Magazine, Plain Trigger, 8 1/2 lbs.....	each	19.50
26 " Octagon " " " " " 8 1/2 "	"	21.00

SAVAGE HAMMERLESS SPORTING RIFLES

DESCRIPTION OF SYSTEM, MODEL 1895

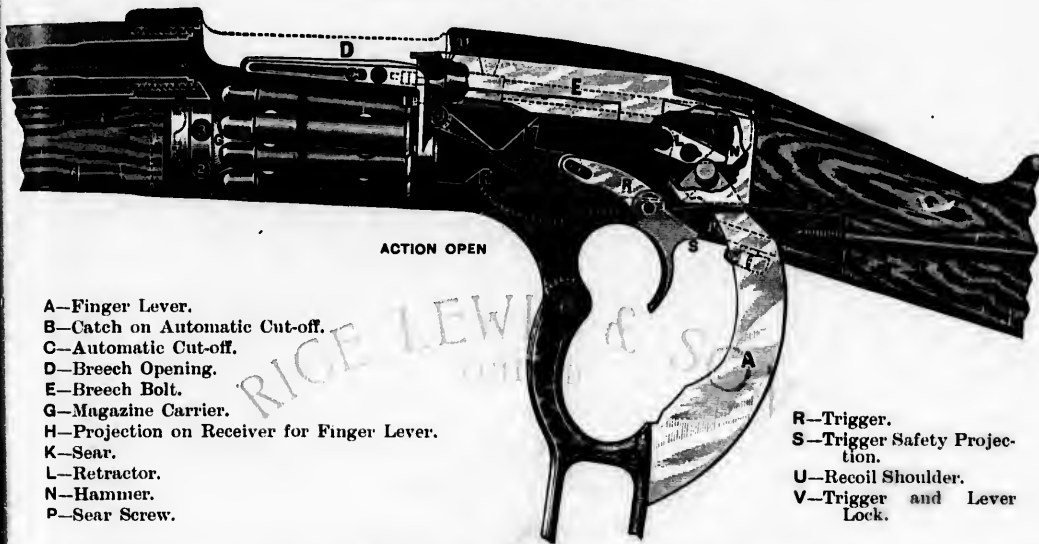

ACTION OPEN

- A—Finger Lever.
- B—Catch on Automatic Cut-off.
- C—Automatic Cut-off.
- D—Breech Opening.
- E—Breech Bolt.
- G—Magazine Carrier.
- H—Projection on Receiver for Finger Lever.
- K—Sear.
- L—Retractor.
- N—Hammer.
- P—Sear Screw.

- R—Trigger.
- S—Trigger Safety Projection.
- U—Recoil Shoulder.
- V—Trigger and Lever Lock.

This Rifle is without a doubt the most wonderful of all latest improvements in the line of sporting weapons. While unique and handsome in its appearance, it is of the strongest style, the best workmanship, and will stand heavy charges, as is absolutely necessary in nitro guns. It is so constructed that premature explosion is next to impossible—the magazine being as shown in above cut, and the cartridges lie side by side instead of following each other up a long magazine. The trajectory is very flat and the velocity very great, so that for average sporting the Rifle can be used up to say 200 yards without changing sight. Penetration is very great, the velocity being so great and the barrel having one turn to every 10 inches (i. e., 2½ turns in 26 in. barrel). For very hard shooting it is necessary to use either full jacketed or expansive jacketed balls; for light shooting, say up to 100 yards, the miniature cartridge with lead ball makes a very nice ammunition.



.303 CALIBRE, FOR SMOKELESS POWDER

26 inch, Round Barrel, holds 6 Cartridges, Weight 7½ lbs.	each	\$27.05
26 " Half Octagon Barrel, " 6 " " 7½ "	"	29.50
26 " Full " " 6 " " 7½ "	"	29.50

Can also supply Carbine same make as this Rifle.

DAISY AIR RIFLES



REPEATER

SINGLE SHOT

Daisy Repeater, holds 48 B.B. Shot, Walnut Stock, Globe Sights	per doz.	\$19.50
Daisy Single Shot (20th Century) suitable for B.B. Shot or Darts	"	16.00

The Daisy Repeater will not shoot Darts.

DARTS, suitable for 20th Century Single Shot Daisy Rifles	per gross	7.00
---	-----------	------

REVOLVERS

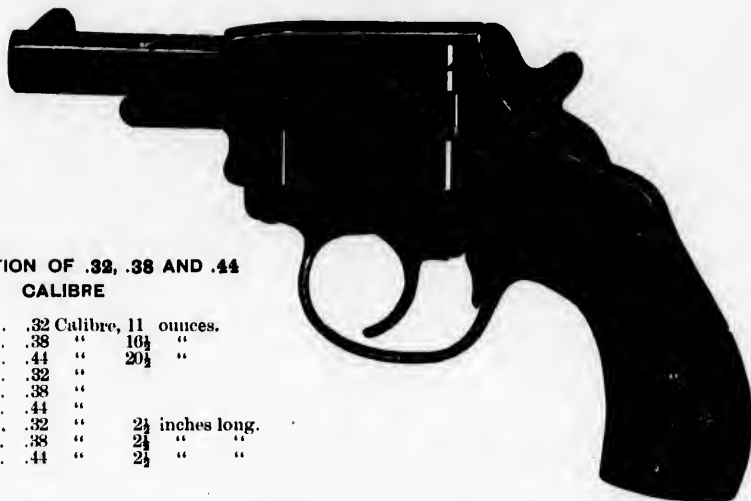

DESCRIPTION OF .32, .38 AND .44 CALIBRE

Weight.....	.32 Calibre, 11 ounces.
".....	.38 " 10½ "
".....	.44 " 20½ "
Cartridge.....	.32 " "
".....	.38 " "
".....	.44 " "
Barrel.....	.32 " 2½ inches long.
".....	.38 " 2½ " "
".....	.44 " 2½ " "

American Bull Dog, .32 or .38 Calibre, Centre Fire.....	each	\$2.85
" " " .44 Calibre, Centre Fire.....	"	3.20

BOSTON BULL DOG

Same style as American Bull Dog but lighter in weight.

Boston Bull Dog, .22 Calibre, Rim Fire.....	each	2.85
" " " .32 " Centre Fire.....	"	2.85

.32 Cal
.32 "
.32 "
.38 "
.38 "
.38 "

MERWIN, HULBERT & CO.'S REVOLVERS

Turning the Barrel on the Centre Stem and drawing it forward ejects all the Shells.

WITH FOLDING HAMMER,



C. F.—.32 Calibre, 3 inch Barrel, 5 Shot.....	each	\$18.50
" —.32 " 3½ " " 7 "	"	21.00
" —.38 " 3½ " " 5 "	"	21.00
" —.38 " 5½ " " 5 "	"	22.00

.32 Calib
.32 "
.32 "
.38 "
.38 "
.38 "

REVOLVERS

IVER JOHNSON SAFETY HAMMER AUTOMATIC REVOLVERS



	.32 Calibre, 3 inch Barrels, Nickel		each.	\$5.50
	.32 " 3 " Blued		"	6.15
	.32 " 6 " Nickel		"	7.35
	.38 " 3½ " Nickel		"	5.50
	.38 " 3½ " Blued		"	6.15
	.38 " 6 " Nickel		"	7.35

IVER JOHNSON SAFETY HAMMERLESS AUTOMATIC REVOLVERS



	.32 Calibre, 3 inch Barrels, Nickel		each.	6.75
	.32 " 3 " Blued		"	7.35
	.32 " 6 " Nickel		"	8.00
	.38 " 3½ " Nickel		"	6.75
	.38 " 3½ " Blued		"	7.35
	.38 " 6 " Nickel		"	8.00

CARTRIDGES

RIM FIRE

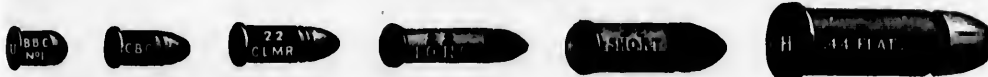

Blank Cartridges same List as Ball Cartridges, except .22 and .32.

	Per 1000.		Per 1000.
B.B. Caps	\$4.00	.38 Short	10.00
C.B. "	4.50	.38 Long	18.00
.22 Short, 50 in a box	5.00	.38 Extra Long	25.00
.22 " 100 "	5.00	.41 Short	15.00
.22 " Mushroom, 50 in a box	5.50	.41 Long	17.50
.22 " " 100 "	5.50	.42 Calibre, No. 64, Forehand and W	30.00
.22 Long, 50 in a box	6.00	.44 Short	23.00
.22 " 100 "	6.00	.44 Long	25.00
.22 Colt's M.R. Short, 50 in a box	5.00	.44 Henry, Flat	24.00
.22 " " 100 "	5.00	.44 " Pointed	25.00
.22 " " Long, 50 "	6.00	.44 C. and W.	25.00
.22 " " 100 "	6.00	.44 Howard, Long	27.00
.22 Long, Rifle, 50 in a box	6.00	.44 Extra Long	36.00
.22 " " 100 "	6.00	.46 Short, Pistol	25.00
.22 Extra Long	9.00	.46 Long, Rifle	33.00
.22 Winchester	9.00	.46 Extra Long	40.00
.25 Short	8.50	.56-46 Spencer Sporting	40.00
.25 Stevens'	14.00	.56-50 " Carbine	10.00
.30 Short	9.00	.56-52 " Rifle	40.00
.30 Long	10.50	.56-56 " Carbine	40.00
.32 Extra Short	10.00		
.32 Short	10.00	SHOT CARTRIDGES, .22 Long	11.00
.32 Long	11.50	" .32 "	22.00
.32 Long, Rifle	11.50	BLANKS, .22 Short	5.00
.32 Extra Long	16.50	" .32 "	10.00

each \$14.85
" 14.85
" 16.40
" 17.10

CENTRAL FIRE, PISTOL SIZES

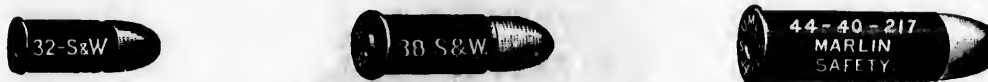

Blank Cartridges same List as Ball Cartridges.

Primer.	Per 1000.	Primer.	Per 1000.
No. 1 -.22 Extra Long	\$13.00	No. 1 -.38-40 Marlin	19.00
" 1 -.22 Winchester	15.00	" 1 -.38 Extra Long	23.00
" 1 -.25-20 Grs. Stevens' and Winchester	18.00	" 0 -.41 Short, Colt's Single Action	15.00
Single Shot	18.00	" 0 -.41 " " Double "	15.00
" 1 1/4 -.25-20 Marlin and Winchester	16.00	" 1 -.41 Long, " "	17.50
" 1 -.300 Rook	15.00	" 0 -.44 S. & W. No. 3, American	10.00
" 1 -.32 Protector	9.00	" 2 -.44 " " " 3, Russian	20.00
" 1 -.32 Ideal	20.00	" 2 -.44 " " Russian Gallery, Round Ball	22.00
" 0 -.32 Short Colt's	11.00	" 2 -.44 " " " Grooved	25.00
" 0 -.32 Long	12.00	" 1 -.44 Merwin, Hulbert & Co	20.00
" 1 -.32 " Colt's, Inside Lubricant	12.00	" 2 -.44 Colt's	20.00
" 1 -.32 " Rifle	12.00	" 1 -.44 Long, Ballard	22.00
" 0 -.32 Smith & Wesson Gallery, Round Ball	10.00	" 1 -.44 Extra Long, Wesson	30.00
" 0 -.32 "	11.00	" 1 -.44 " Ballard	30.00
" 0 -.32 H. & R. or M. H. & Co	14.00	" 1 -.44 Winchester	19.00
" 1 -.32 Winchester	16.00	" 1 -.44 Colt's M. R. for Colt's Lightning Rifle	19.00
" 1 -.32 Colt's M. R. for Colt's Lightning Rifle	10.00	" 1 -.44-40 Marlin	19.00
" 1 -.32-20 Marlin	16.00	" 2 1/2 -.44 Evans' New Model	20.00
" 1 1/4 -.32-30 Remington Grooved	25.00	" 1 -.44 " Old	22.00
" 1 1/4 -.32 Extra Long Ballard	18.00	" 1 -.44 Webley	16.50
" 1 1/4 -.32 " Smith & Wesson Rifle	20.00	" 1 -.44 Bull Dog	14.50
" 1 -.32-44 S. & W. Gallery, Round Ball	18.00	" 1 -.45 Webley	20.00
" 1 -.32-44 " " Target, Grooved	19.00	" 1 -.45 Smith and Wesson	25.00
" 0 -.38 " " Gallery, Round Ball	12.50	" 2 -.45 Colt's U.S.A.	22.00
" 0 -.38 " "	13.50	" 2 -.45 " " 28 Grs.	22.00
" 1 -.38-44 " " Target, Grooved	23.00	" 2 -.45 " Round Ball	22.00
" 1 -.38-44 " " Gallery, Round Ball	19.00	" 1 -.450 Revolver	15.00
" 0 -.38 Merwin, Hulbert & Co	13.50	" A -.50 Pistol	28.00
" 0 -.38 Short	13.50		
" 1 -.38 Long, for Colt's D. A. Pistols, etc.	14.50	SHOT CARTRIDGES, .38 W.C.F. and 44 W.C.F.	20.00
" 1 -.38 Winchester	19.00	BLANKS, .32 Smith & Wesson	11.00
" 1 -.38 Colt's M. R. for Colt's Lightning Rifle	19.00	" .38 "	13.50

each 16.40
" 17.00

each 22.00
" 22.00

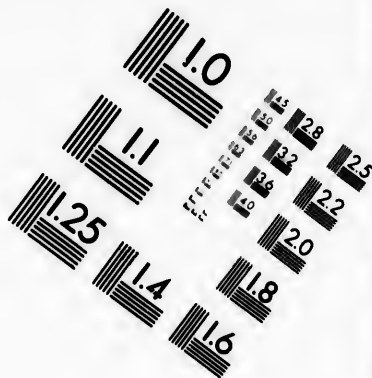
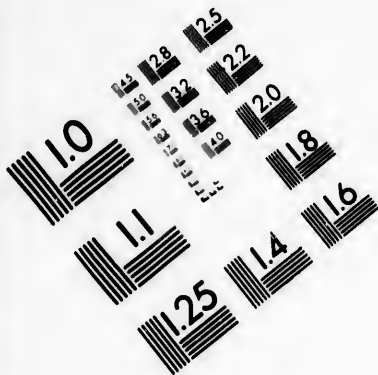

**IMAGE EVALUATION
TEST TARGET (MT-3)**

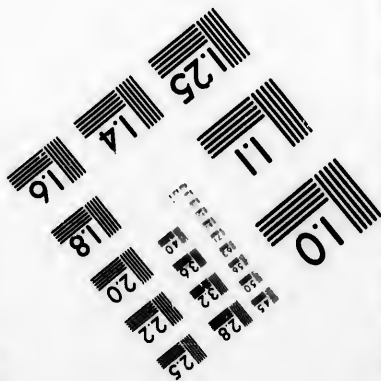
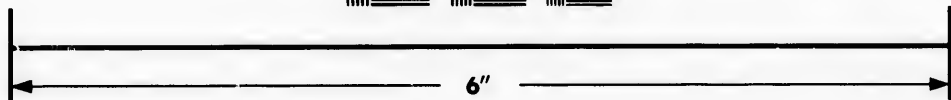
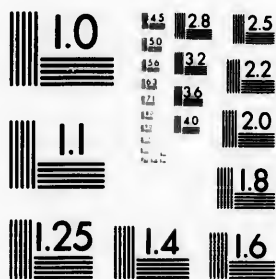

**Photographic
Sciences
Corporation**

23 WEST MAIN STREET
WEBSTER, N.Y. 14580
(716) 872-4503

15 28
13 25
12 22
10 20
8

10

SHOT GUN SHELLS

BRASS SHELLS



American Best.....	per 100	10 x 2 $\frac{1}{2}$	12 x 2 $\frac{1}{2}$	14 x 2 $\frac{1}{2}$	16 x 2 $\frac{1}{2}$
" 2nd.....	"	\$10.50	10.00	10.00	10.00
		8.00	8.00

PAPER SHELLS



Size.....	per 1000	10 x 2 $\frac{1}{2}$	12 x 2 $\frac{1}{2}$	12 x 2 $\frac{1}{2}$	14 x 2 $\frac{1}{2}$	16 x 2 $\frac{1}{2}$	20 x 2 $\frac{1}{2}$
Dominion Trap.....		\$9.00	8.00	7.50
" Black.....		9.00	8.00
U. M. C. Black Club.....		9.00	8.00	7.50	7.50	7.50
" Nitro.....		9.00	9.00	8.00	7.50	7.50
Winchester Blue Rival.....		9.00	9.00	8.00
" Repeater.....		8.00
Eley Job.....		8.00
Pin Fire.....	Price on application.						

LOADED SHOT SHELLS



DOMINION TRAP, 12 GAUGE

DOMINION TRAP, 10 GAUGE

Load Number.	Weight of Powder.	Weight of Shot.	Size of Shot.	Price per 1000	Load Number.	Weight of Powder.	Weight of Shot.	Size of Shot.	Price per 1000
D.....	3 Drs.	1 $\frac{1}{2}$ Oz.	4	\$20.50	O.....	4 Drs.	1 $\frac{1}{2}$ Oz.	3	\$23.50
D.....	3 "	1 $\frac{1}{2}$ "	5	20.50	O.....	4 "	1 $\frac{1}{2}$ "	4	23.50
D.....	3 "	1 $\frac{1}{2}$ "	6	20.50	O.....	4 "	1 $\frac{1}{2}$ "	5	23.50
D.....	3 "	1 $\frac{1}{2}$ "	7	20.50	O.....	4 "	1 $\frac{1}{2}$ "	6	23.50
D.....	3 "	1 $\frac{1}{2}$ "	8	20.50	O.....	4 "	1 $\frac{1}{2}$ "	8	23.50
D.....	3 "	1 $\frac{1}{2}$ "	10	20.50	O.....	4 "	1 $\frac{1}{2}$ "	10	23.50
G.....	3 $\frac{1}{2}$ "	1 $\frac{1}{2}$ "	3	21.00	U.....	4 $\frac{1}{2}$ "	1 $\frac{1}{2}$ "	3	24.00
G.....	3 $\frac{1}{2}$ "	1 $\frac{1}{2}$ "	4	21.00	U.....	4 $\frac{1}{2}$ "	1 $\frac{1}{2}$ "	4	24.00
G.....	3 $\frac{1}{2}$ "	1 $\frac{1}{2}$ "	5	21.00	U.....	4 $\frac{1}{2}$ "	1 $\frac{1}{2}$ "	5	24.00
G.....	3 $\frac{1}{2}$ "	1 $\frac{1}{2}$ "	6	21.00	U.....	4 $\frac{1}{2}$ "	1 $\frac{1}{2}$ "	6	24.00
G.....	3 $\frac{1}{2}$ "	1 $\frac{1}{2}$ "	7	21.00	U.....	4 $\frac{1}{2}$ "	1 $\frac{1}{2}$ "	8	24.00
G.....	3 $\frac{1}{2}$ "	1 $\frac{1}{2}$ "	8	21.00	U.....	4 $\frac{1}{2}$ "	1 $\frac{1}{2}$ "	8	24.00
G.....	3 $\frac{1}{2}$ "	1 $\frac{1}{2}$ "	10	21.00	U.....	4 $\frac{1}{2}$ "	1 $\frac{1}{2}$ "	10	24.00
J.....	3 $\frac{1}{2}$ "	1 $\frac{1}{2}$ "	3	21.50					
J.....	3 $\frac{1}{2}$ "	1 $\frac{1}{2}$ "	4	21.50					
J.....	3 $\frac{1}{2}$ "	1 $\frac{1}{2}$ "	5	21.50					
J.....	3 $\frac{1}{2}$ "	1 $\frac{1}{2}$ "	6	21.50					
J.....	3 $\frac{1}{2}$ "	1 $\frac{1}{2}$ "	8	21.50					
J.....	3 $\frac{1}{2}$ "	1 $\frac{1}{2}$ "	10	21.50					

LOADED SHOT SHELLS

AMERICAN



12 GAUGE					10 GAUGE				
Load No.	Weight of Powder.	Weight of Shot.	Size of Shot.	Price per 1000.	Load No.	Weight of Powder.	Weight of Shot.	Size of Shot.	Price per 1000.
100.....	3 Drs.	1 Oz.	10	\$25.00	210.....	4 Drs.	1 1/2 Oz.	10	\$20.00
106.....	3 "	1 "	6	25.00	241.....	4 "	1 1/2 "	4	20.00
96.....	3 "	1 1/4 "	6	26.00	246.....	4 "	1 1/2 "	6	20.00
98.....	3 "	1 1/4 "	8	26.00	247.....	4 "	1 1/2 "	7	20.00
122.....	3 1/2 "	1 1/4 "	2	26.50	256.....	4 "	1 1/2 "	6	30.00
123.....	3 1/2 "	1 1/4 "	3	26.50	258.....	4 "	1 1/2 "	8	30.00
124.....	3 1/2 "	1 1/4 "	4	26.50	274.....	4 1/2 "	1 1/2 "	4	30.50
125.....	3 1/2 "	1 1/4 "	5	26.50	275.....	4 1/2 "	1 1/2 "	5	30.50
126.....	3 1/2 "	1 1/4 "	6	26.50	276.....	4 1/2 "	1 1/2 "	6	30.50
127.....	3 1/2 "	1 1/4 "	7	26.50	277.....	4 1/2 "	1 1/2 "	7	30.50
128.....	3 1/2 "	1 1/4 "	8	26.50	278.....	4 1/2 "	1 1/2 "	8	30.50
134.....	3 1/2 "	1 1/4 "	4	27.00	282.....	4 1/2 "	1 1/2 "	2	30.00
135.....	3 1/2 "	1 1/4 "	5	27.00	283.....	4 1/2 "	1 1/2 "	3	30.00
136.....	3 1/2 "	1 1/4 "	6	27.00	286.....	4 1/2 "	1 1/2 "	6	31.00
191.....	3 1/2 "	1 1/4 "	BB	29.50	288.....	4 1/2 "	1 1/2 "	8	31.00

HAND LOADED SMOKELESS SHOT SHELLS

Loaded with C. & H. Amberite Powder.

12 GAUGE				10 GAUGE			
Weight of Powder.	Weight of Shot.	Size of Shot.	Price per 1000.	Weight of Powder.	Weight of Shot.	Size of Shot.	Price per 1000.
3 Drs.	1 1/4 Oz.	Any number 1 to 10	\$47.75	3 1/2 Drs.	1 1/4 Oz.	Any number 1 to 10	\$52.50

Price on application of any Special Loads.

GUN CAPS

PRIMERS

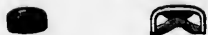

				Per 1000.				
Dominion	1	1 1/2	2	2 1/2	\$2.00			
U. M. C.	1	1 1/2	2	2 1/2	3	5	8 1/2	2.00
Winchester..	1	1 1/4	1 1/2 W	2	2 1/4 W	3 W	2.00	

PERCUSSION CAPS



					Per 1000.		
E. B..	10	11	12	13	14	18	\$0.83
U. M. C.....	10	11	12	0.90			

MILITARY CAPS



			Per 1000.
Snider-Enfield Size			\$1.25

25 lb. K

C

Per Tin

C

Nos. ...

25 lb. K

12 1/2 "

1 lb. T

1/2 "

25 lb. K

Soft Sho

Chilled S

Dust, or

POWDER

SOLE AGENTS FOR CURTIS'S & HARVEY'S BLACK AND NITRO POWDERS

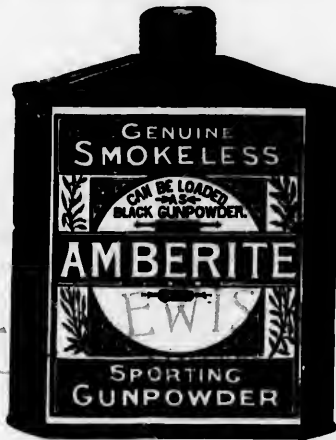

C. & H. BLACK POWDER

	F	FF	FFF	T.P
25 lb. Kegs..... per keg.	\$5.30	5.05	5.05	9.40

C. & H. "HONKER" DUCKING POWDER

Coarse or Medium Grain.

	25	12½	6¼	1 lb. tins.
Per Tin.....	\$12.50	6.50	3.30	0.55

C. & H. CELEBRATED "DIAMOND GRAIN"

Nos.....	4	6
25 lb. Kegs..... per keg.	\$18.75	18.75
12½ ".....	10.15	10.15
1 lb. Tins..... per doz.	11.25	11.25
½ ".....	6.25

HAMILTON BLASTING POWDER

25 lb. Kegs..... per keg.	2.50
---------------------------	------

C. & H. AMBERITE SMOKELESS POWDER

Tins.....	½	1	5 lb.
Per lb.....	\$2.20	2.05	2.00

Amberite Smokeless Powder contains no Nitro-Glycerine, gives a high muzzle velocity with low pressure and is quick in ignition. It is a hard, clean grain, and practically unaffected by cold, heat or moisture. It is a safe and pleasant powder to shoot with and loads measure for measure with Black Powder.

SAVAGE SMOKLESS POWDER

No. 1.....	For High Pressure Savage Cartridges.
" 2.....	For Miniature
In Tins (about 1 lb.)..... per tin.	\$1.85

DYNAMITE

	30%	40%	50%	60%	75%
	Price on Application.				
Detonators..... per 1000.	\$11.25				

SHOT

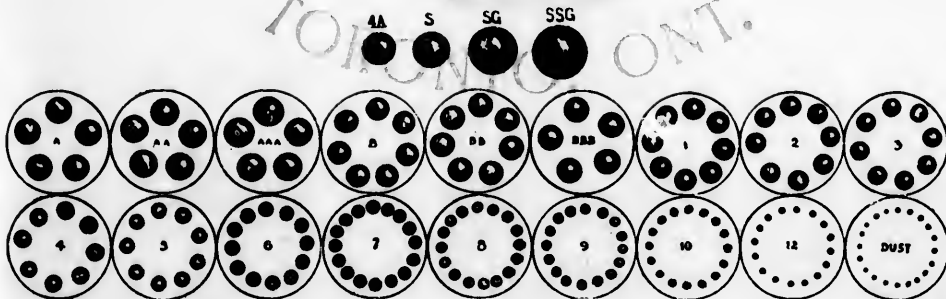

Soft Shot, Dust to No. 3A.....	per lb.	\$0.00
" 4A, S, SG, and SSG (Buck Shot).....	"	0.07
Chilled Shot, Dust to No. 3A.....	"	0.06½

Approximate Number of Pellets to the Ounce.

Dust, or No.	12	10	9	8	7	6	5	4	3	2	1	B	BB	BBB	A	AA	AAA	AAAA	SS	SG	SSG
	982	882	500	375	278	209	160	121	98	92	69	58	49	44	38	32	27	24	15	11	10

Price per 1000.
\$20.00
29.00
29.00
29.00
30.00
30.00
30.50
30.50
30.50
30.50
31.00
31.00

Price per 1000.
\$52.50

CAPS
Per 1000.
Size \$1.35

ELECTRIC BLASTING SUPPLIES



SHOWING CHARGE HOLES CONNECTED IN SERIES

A, hole in rock; B, dynamite charge in hole; C, electric fuses in dynamite charge; D, connecting wire joining fuse wires together; E, leading wire from battery to fuse wires; F, electric blasting machine or battery.

The above cut represents clearly the manner of connecting holes for firing by electricity. It is called "connecting in series," and is the system universally adopted. The electric fuse wire should be about the same length as the hole is deep; better to have the wire a little longer, that it may project above the surface of the hole after it is tamped, for the purpose of connecting it to the wire of the next hole.

MAKING THE JOINT

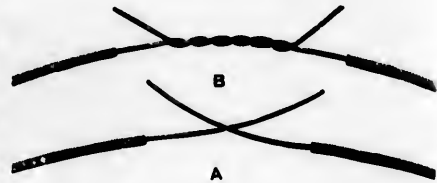

This illustration represents the usual way of making joints. First cross the ends of the wire as shown in Cut A, then twist the ends as shown in Cut B, being particular to twist close and tight, as a slack joint or twist is not a good connection; be sure to have the ends clean and bright. Keep bare joints off the ground and out of the water. Where it is not convenient to do so, they should be covered with insulating tape.

BLASTING MACHINES



VICTOR No. 1



No. 3, PULL UP



No. 3, PUSH



No. 4, PUSH

	VICTOR No. 1	No. 3, PULL UP	No. 3, PUSH	No. 4, PUSH
Each.....	\$30.00	37.50	37.50	75.00

DOUB
Insulating
Leading

Connecti
Single T
Double
White Co



ELECTRIC BLASTING SUPPLIES



INSULATING TAPE

LEADING WIRE



Insulating Tape per lb. \$3.00
 Leading Wire " 0.50

CONNECTING WIRE



Connecting Wire per lb. 0.50

BENNETT'S CELEBRATED BLASTING FUSE

In 50 ft. lengths, papered.

Single Tape Fuse per 1000 feet \$4.00
 Double " " 0.75
 White Countered Gutta-Percha Fuse " 7.15

The White Countered Gutta-Percha Fuse gives off small volume of smoke, and is not affected by heat or cold.

VICTOR ELECTRIC FUSES

Improved Waterproof Insulation.

SINGLE STRENGTH

Ordinary Quality equal to Quintuple Force.

Wires	4	6	8	10	12	16	20	24 feet.
Per 100	\$4.50	5.30	6.10	7.00	7.75	9.35	11.00	14.00

DOUBLE STRENGTH

Extra Quality equal to Double Quintuple Force.

Wires	4	6	8	10	12	16	20	24 feet.
Per 100	\$5.05	6.50	7.25	8.00	8.00	10.50	12.00	15.00



50 Fuses in each box.



GUN WADS

ELASTIC



Gauge.....			8	9-10	11 and smaller.
Eley's, Chemically Prepared, Black Edge.....	per 1000		\$1.20	1.10	1.05
U. M. C., " " " ".....				1.16	1.00
U. M. C., " " Pink Edge.....				2.07	1.65

THICK FELT WADS

Eley's, in 1/4-pound bags.....	per 1000		BROWN	GREY
			\$1.00	1.10

THIN CARD WADS

Gauge.....	10	12 and smaller.	Gauge.....	10	11 and smaller.
Eley's.....	per 1000	\$0.30	0.25	U. M. C.....	per 1000
					\$0.37
					0.30

WAD CUTTERS



Gauge.....			8 to 9	10 to 16
Steel, Indented.....	per doz.		\$2.45	1.80

GUN LOCKS

Pright, Front Action.....	per doz.	\$10.00
" Back ".....	"	10.50

GUN HAMMERS

Muzzle.....per doz. \$1.05 | Finished Breech.....per doz. \$3.00 | Breech Blanks.....per doz. \$2.00

GUN WORMS

Size.....	No. 262 x 1/4	No. 263 x 5/16	No. 264 x 3/8
Price.....per gross	\$5.75	6.65	8.65

No. 1180
" 1144

No. 1180

No. X
" 1175

GUN IMPLEMENTS

LOADERS



No. 189



No. 1147

- No. 189—Birch, Polished Nickel Spun Tube and Fine Steel Expelling Pin, 10 and 12 Gauge per doz. \$ 1.00
 " 1147—Barclay Pattern, Boxwood Head and Base, Brass Tube with Inside Spring, the Spring protects the mouth of Shell and seats Wad properly, 10 and 12 Gauge per doz. 10.30

RECAPPER

- No. 1180B—Japanned Finish, 10 to 10 Gauge. Per doz. \$0.00



No. 1180B

SHELL EXTRACTORS



No. X



No. 1175

- No. X—Ringed Extractor, Nickeled Iron, 10 to 12 Gauge per doz. 0.30
 " 1175—Hook " Polished and Nickel-Plated, 10 and 12 Gauge " 1.05

FIELD CLEANER

Made for 10 and 12 Gauge Guns Only.

- No. 442—Cleaner consists of a stiff bristle brush with double slotted wiper, to which is attached a string with weight. Each Cleaner is sent out in a fine leather pouch with clasp. Drop the weight through your gun barrel, and you can then pull the brush through, removing the dirt quite as effectively as you could with the rod. It can be carried in the vest pocket. 10 and 12 Gauge per doz. 12.00



GUN IMPLEMENTS

SHELL CLOSERS

- | | |
|--|--------------------|
| No. O—Japanned Case Hardened Lever,
Brass Cup, 10 and 12 gauge.... | per doz.
\$4.00 |
| " Ox. P.—Same as O, but with expel-
ling pin..... | 5.10 |
| " 3—Japanned, Brass Nickel-Plated
Cup, With Hardened Steel
Pins, Changeable for Either
Round or Square Crimp..... | 20.25 |

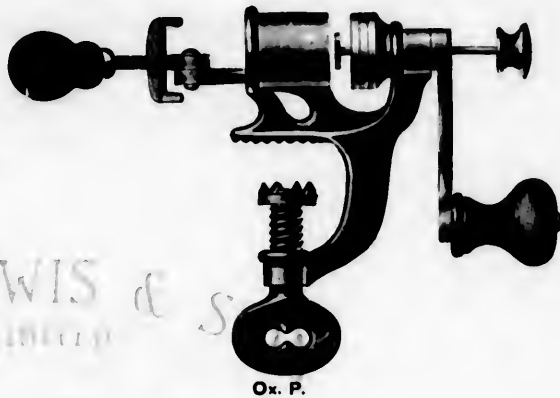

Ox. P.

LOADING SETS

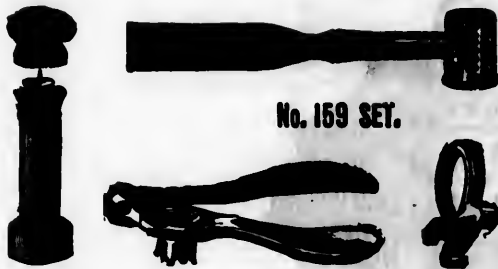

No. 159 SET.

- No. 159—Brass Shell Set, Four Imple-
ments, viz.: Loader, Cap-
per, Shell Extractor, Shot
and Powder Measure, 10 to
12 gauge..... per doz. set \$4.20

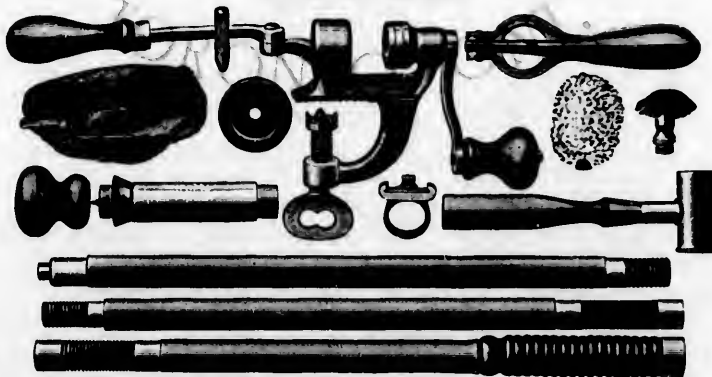

- No. 161—Brass and Paper Shell Set, 6 Implements, viz.: Loader, Closer, Capper, Extractor, Measure,
Cleaning Rod, with Swab Wiper and Scratch Brush, 10 to 16 gauge..... per doz. set 14.00

RIFLE IMPLEMENTS

FIELD CLEANER



No. 250—Bristle Brush and Slotted Wiper, extra Slotted Wiper for Dry Cloth and Oiling, with Weight for dropping through Barrel, .22 to .50 Calibre.....per doz. \$4.00

CLEANING ROD

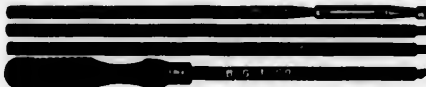

No. 141B—4 Jointed Brass Rod, Slotted and Jagged, with Revolving Handle, Thread Tip for attaching Brush.....per doz. 4.00

CLEANING BRUSHES

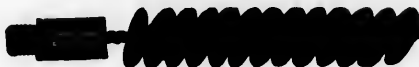

Suitable for No. 250 Cleaner and No. 141B Rod.

No. 246 —Bristle Brush, Twisted Wire Frame and Brass Shank, .22 to .50 Calibre.....per doz. 3.50
 " 246B—Brass Wire Brush, Twisted Wire Frame and Brass Shank, .20 to .50 Calibre..... " 3.50

FLOBERT CLEANING RODS

No. 143—Twisted Wire Rod with Bristle Brush, wound in Tip, .22 to .32 Calibre.....per doz. 0.40
 " 151—Iron Rod, Slotted Ring Handle, .22 to .32 Calibre..... " 0.60

IDEAL BULLET MOULDING SET



Dipper for Running Lead into the Mouldeach 0.50
 Melting Pot..... " 0.50
 " Holder..... " 0.50

No. 1—
 " 2—
 " 3—
 " 3—
 " 4—
 " 6—
 " 6—

For Reloa

For Reloa

RIFLE IMPLEMENTS

IDEAL RELOADING TOOLS



IDEAL No 4

No. 1—For Reloading .32 Shot, .32 Long, .32 and .38 S. & W., &c.	per set	\$2.25
" 2— " " .32-44 S. & W., Target or Gallery, .38-44 S. & W., Target or Gallery	"	4.75
" 3— " " .303 Savage, Single Chamber, Without Mould	"	4.35
" 3— " " .303 " Double "	"	5.10
" 4— " " .32-20, .38-40, .44-40	"	2.50
" 6— " " .32-40, .38-55, .38-50, .40-60W, .40-60M, .40-65, .40-82, .45-60, .45-70W, .45-70M	"	3.00
" 6— " " .303 Savage, Without Mould	"	3.00

WINCHESTER RELOADING TOOLS

LEVER MODEL



For Reloading all Pistol Sizes, and .32, .38 and .44, Winchester Model, 1873.....per set 2.50

NEW MODEL



For Reloading all Sporting and Military Cartridges, .32-40, .38-55, .38-50, .40-60, .40-82, etc.....per set 3.60

RIFLE IMPLEMENTS

BULLET MOULDS



Winchester Make for all Pistol Sizes and .32, .38, .44W Model 1873.....	each	\$1.10
“ “ “ Sporting and Military Sizes.....	“	1.10
“ “ “ Express Cartridges.....	“	1.75
Ideal Make for Savage Miniature .303.....	“	1.90
“ Perfection Mould, Adjustable for Moulding Different Weights of Bullets for any one Calibre, .32-40, .38-55, etc.....	each	4.00

RE-SIZING TOOLS

Ideal for Re-sizing any Calibre Rifle Cartridge.....	each	2.00
--	------	------

RIFLE SIGHTS, FRONT



GLOBE

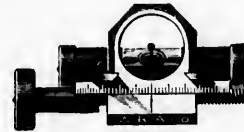

WIND GAUGE

Globe Front Sight with Interchangeable Discs.....	each	1.25
Wind Gauge Front Sight with 3 Discs, Interchangeable.....	“	3.00
“ “ “ 3 “ “ and Spirit Level, “	“	4.00
Bulbs for Spirit Level.....	“	0.15

RIFLE SIGHTS, REAR



ROCKY MOUNTAIN

Rocky Mountain Rear Sight, Winchester.....	each	0.80
“ “ Marlin, for Model 91 and 92, etc.....	“	0.80
“ “ “ 89 and 94, etc.....	“	0.80
Sporting Leaf Sight to Fit in Rear Slot.....	“	1.50
Rear Midrange Vernier Peep Sight.....	“	4.00



VERNIER

Co
The P
When aiming
ring of hoop, v

are seen as dist
no rear sight wa
These sights
double the valu
either for hunti
get shooting; fo
neous aim can
with great accu
The large aper
be used for nearl
ing.
This cut show
BLANK stop-pi
sight stem, to p
sight from bein
down too low.
Any one can a
sights to a rifle
minutes.
When of
make and size of
**Ivory Bead
Front Sight.**

dist
ject
brig
No 3 Price \$1.00
**Ivory Combin
Front Sight**

No. 5. Pric
This is an e
sight for "all roun
The cuts show
Ivory and the
globe.
Win

Showing Apertur
This is the best
Rifle. It has a r
can be changed qu
close to the barre
and it is locked
The front sight
ould be driven
and side.

LYMAN'S PATENT SIGHTS.

Combination Rear Sight.

The Principle of Perfect Alignment.

When aiming this sight has the appearance of a ring or hoop, which shows the front sight and the object aimed at, without intercepting any part of the view.



It will be noticed in the clear cut that the top of rifle barrel and front sight

are seen as distinctly as if no rear sight was used.

These sights more than double the value of a rifle, either for hunting or target shooting; for instantaneous aim can be taken with great accuracy.

The large aperture should be used for nearly all shooting.

This cut shows the POINT BLANK stop-pin in the sight stem, to prevent the sight from being turned down too low.

Any one can attach these sights to a rifle in a few minutes.

When ordering give make and size of rifle.

Ivory Bead Front Sight.

These sights can be seen distinctly against any object in the woods or in the bright sunlight.

No. 3 Price \$1.00.

Ivory Combination Front Sight.



No. 5. Price \$1.00.

This is an excellent sight for "all round" use. The cuts show the open ivory and the shaded globe.

Ivory Hunting Front Sight.

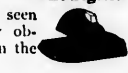

No. 4. Price 50.

Sporting Wind-gauge Sight.



No. 8. Price \$3.00.

A good sight for general shooting. It is the Combination Front Sight on the wind-gauge base.

Wind-gauge Target Sight.



Showing Aperture.

Showing Globe.

No. 7. Price \$3.50.

This is the best Wind-gauge ever made for a Match Rifle. It has a reversible globe and aperture which can be changed quickly. It is compact in form, being close to the barrel. When set for a given point of wind it is locked by a spring clamp firmly in position.

NOTICE.

The front sight, blank, spirit level and leaf sight should be driven into the barrel slot from the right-hand side.

Combination Rear Sight, showing the small aperture in use.



No. 1. Price \$3.00.

Combination Rear Sight, with Cap Disc.



No. 2. Price \$3.50.

This sight has a large detachable disc and is intended for Match Rifles and Gallery Rifles. It is not as good for "all round" shooting as the \$3.00 combination sight. Many target shooters like it, as it is much better than the Vernier peep sight.

The disc is easily removed, and for most work is not needed.

For gallery practice the aperture in the disc can be enlarged to advantage. When ordering, give the make and size of rifle.



IVORY SHOT GUN SIGHTS.

A New System of Sighting Shot Guns.



No. 9. Price, per set, \$1.00.

The left-hand cut shows the large muzzle or front sight. The right-hand cut the small rear sight which is placed about sixteen inches from the muzzle sight.

The first engraving gives the appearance of the sights when aiming at a straight-way bird. The elevation of the gun is right, but the rear sight shows that the gun is out of line, which would not be discovered if these sights were not used. This system is a great help both in field and at the trap.

Leaf Sight.



Both leaves folded down.

Using the straight bar.

Using the croch.

No. 6. Price \$1.00.

One leaf is a bar with a triangular ivory center, the other is a wide open V croch.

Many sportsmen who use the Lyman rear sights do so with the ordinary croch sight on the barrel. This is much in the way and the shooting is done at a great disadvantage. Lyman's leaf sight can be put in place of it. It folds down close to the barrel, allowing the shooter to use the combination sight in an unobstructed manner, and the result is that the shooting is twice as good as when the ordinary croch sight is on the barrel. Although the shooter should in any case use the Lyman tang sights for nearly all shooting, he has the satisfaction of knowing that if he wishes to use this leaf sight, that it is the best form of croch and bar sight in use.

The bar leaf is excellent as a twilight sight or when used at night with a jack.

The right-hand screw, as indicated by arrow, ad justs the leaves to fold as tightly as desired.

Slot Blank.



No. 12. Price 25c.

This Slot Blank can be used to replace the ordinary croch sight, if the leaf sight is not used.

Send for free Catalogue of Sights, giving testimonials and full information.

GUN AND RIFLE COVERS

FULL LENGTH CANVAS



No. 46B

- | | | |
|--|----------|--------|
| No. 10 —Brown or Drab Canvas, with Button Flap, without Handle, 24 to 30 inch..... | per doz. | \$3.00 |
| " 46B—Brown or Tan Duck, Leather Bound, with Handle for Repeating Rifles, 24 and 20 inch... | " | 8.00 |
| " 46C—Same as 46B, for Shot Guns, 30 inch..... | " | 9.10 |
| " 50B—Heavy Waterproof Tan Duck, Leather Bound, Flannel Lined, with Sling Strap, for Magazine Rifles, 24 to 28 inch..... | per doz. | 12.00 |
| " 50C—Same as 50B, for Shot Guns, 30 inch..... | " | 12.00 |



No. 051B

- | | | |
|---|-------|-------|
| No. 051B—Heavy Waterproof Tan Duck, Leather Bound, Flannel Lined, Lock and Muzzle Leather Protected, with Combination Sling and Handle for Repeating Rifles, 24 and 20 inch... per doz. | 18.00 | |
| " 051C—Same as 051B, for Shot Guns, 30 inch..... | " | 18.00 |

MUTTON LEG

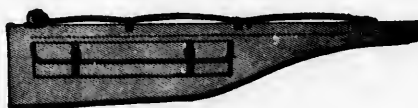

No. 056B

- | | | |
|---|----------|-------|
| No. 06C—Heavy Waterproof Tan Duck, Leather Bound, Flannel Lined, Leather Muzzle Protector, with Combination Sling and Handle..... | per doz. | 19.50 |
| " 056B—Heavy Oak Tan Leather, Flannel Lined, with Handle and Sling Strap, Rod Pocket, Nickel Trimmings..... | each. | 5.45 |
| " 061 —Heavy Oak Tan Leather, Flannel Lined, with Handle and Sling Strap, Rod Pocket, with Lock Buckle..... | each. | 7.75 |



No. 56

- | | | |
|---|----------|-------|
| No. 63F—Tan Duck, Leather Bound, Flannel Lined, with Handle..... | per doz. | 10.10 |
| " 62F—Same as 63F, but has Tool Pocket..... | " | 12.75 |
| " 64F—Heavy Waterproof Tan Duck, Leather Bound, Flannel Lined, with Tool Pocket and Handle..... | " | 15.50 |
| " 66F—Same as 64F, but has Lock and Muzzle Leather Protected..... | " | 20.45 |
| " 56 —Heavy Oak Tanned Leather, Embossed, with Rod Pocket..... | each. | 7.75 |

CARTRIDGE BAGS



CARTRIDGE BAG



CARTRIDGE BELT



REVOLVER HOLSTER



HUNTING COAT

- | | |
|---|----------|
| No. 76—Heavy Tan Duck, Leather Bound, Double Pocket, holds 50 Shells..... | Per doz. |
| " 83—Extra Heavy Tan Duck, Leather Bound, Double Pocket, holds 75 Shells..... | \$0.75 |
| | 11.10 |

GAME BAGS

- | | |
|---|-------|
| No. 100C—Heavy Tan Duck, Leather Bound, Medium Size, with Shoulder Strap..... | 14.00 |
|---|-------|

BELTS

- | | |
|--|-------|
| No. 91—Russet Leather, 2 inch wide, Plain, with Roller Buckle... | 1.30 |
| " 98— " " 2 1/2 " " with Leather Loops, holds from 30 to 30 Cartridges, any calibre..... | 10.00 |
| " 194—Canvas, with Leather Loop, 10 and 12 Gauge, holds about 25 Shells..... | 5.45 |
| " 195—Same as 194 but with Shoulder Strap..... | 7.15 |
| " 93—Russet Leather, 2 1/2, with Leather Loops and Shoulder Strap, 10 and 12 Gauge, holds about 25 Shells..... | 12.00 |

REVOLVER HOLSTERS

- | | |
|--|-------|
| No. 101—32 Calibre, Russet Leather with Flap..... | 6.05 |
| " 102—38 " " " " " "..... | 7.50 |
| " 104—38 x 6 " New Navy Revolver, Russet Leather with Flap | 10.25 |

HATCHET COVERS

- | | |
|--|------|
| Russet Leather with Belt Loops, to fit Tomahawk, or Hunter Pattern | |
| Axe..... | 7.75 |

HUNTING COATS

- | | |
|---|-------|
| No. 1—Heavy Drill, Dead Grass Color, 6 Outside Pockets, 2 Inside Skirt Game Pockets..... | 16.00 |
| " 3—8 ounce Duck, Dead Grass Color, Corduroy Collar, 6 Outside Pockets with Flaps, Full Inside Game Pockets.. | 23.25 |
| " 5—8 ounce Army Duck, Double Stitched, Dead Grass Color, Drill Lined, Corduroy Collars and Cuffs, 6 Reinforced Outside Pockets with Flaps, 3 Game Pockets with Front Edge and Back Seam Entrances, Shoulders Reinforced..... | 36.75 |
| " 12—Best Quality 10 ounce Army Duck, Dead Grass Color, Full Lined 8 ounce Army Duck, otherwise same as No. 5. | 47.00 |
| " 14—Heavy Tan Duck and Corduroy Reversible Patent Buttons Pockets both sides..... | 5.15 |
| " 20—Black Leather, Oil Tanned, Waterproof Tweed Lining, Patent Buttons..... | 6.75 |
| " 30—Same as 20 but Corduroy Lined..... | 7.15 |
| " 40—Green or Tan Leather, Oil Tanned, Waterproof and Corduroy Reversible Patent Buttons, pockets both sides.. | 9.75 |

VESTS

- | | |
|---|----------|
| No. 5—8 ounce Army Duck, Dead Grass Color, with Loops for 40 Shells, will fit .10 or .12 Gauge..... | Per doz. |
| | 18.00 |

PANTS

- | | |
|--|-------|
| No. 17—8 ounce Army Duck, Dead Grass Color, 4 Patch Pockets Double Stitched..... | 20.00 |
|--|-------|

CAPS



No. 31D—English Corduroy, Windsor Style..... per doz. \$13.50

LEGGINGS



No. 15—Knee, Heavy Canvas, Tan Color, to Buckle, Leather Bound Top and Bottom..... per doz. \$12.70
 " 18— " " " " to Lace, " all Round..... " 12.70
 " 5— " 20 ounce, Waterproof Canvas, Tan Color, to Buckle, Tape Seams, Leather Bound Top and Bottom..... per doz. 17.50

BLUE ROCKS



500 in Barrel..... per 1000 \$7.50

DUCK CALLS



No. 780H—With Horn End, Brass Tongue, per doz. 6.10
 " 780 — " Plated End, " " 3.40

EXPERT TRAPS



Expert Traps..... each 6.00

DECOY DUCKS



Best Quality, Ordinary Sizes, Black or Grey Mallards. Prices on application.

Nos...
 New V
 "

Nos.....
 With Ch
 Without
 Discoun
 "
 No. 0 ad
 No. 1

No. 5—V
 Extra Sp

STEEL GAME TRAPS

NEW VICTOR



Nos.....	0	1	1½	2	3
New Victor, with Chains..... per doz.	\$4.25	5.00	7.50	10.50	14.00
“ without Chains..... “	3.25	3.75	6.00	9.00	12.00

RICE LEWIS & SON

NEWHOUSE PATTERN

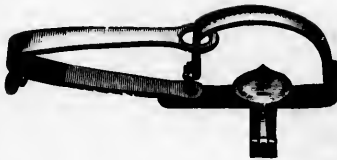

SINGLE SPRING

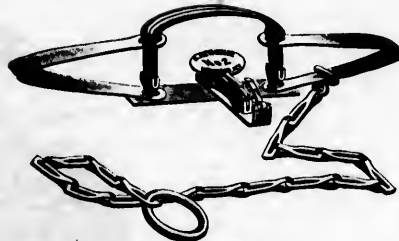

DOUBLE SPRING

Nos.....	0	1	1½	2	Nos.....	2	3	4
With Chains..... per doz.	\$4.25	5.00	7.50	10.50	With Chains..... per doz.	\$10.50	14.00	16.50
Without Chains..... “	3.25	3.75	6.00	9.00	Without Chains..... “	9.00	12.00	14.50
Discount, Newhouse..... %					Discount, Newhouse..... %			
“ Hawley & Norton..... %					“ Hawley & Norton..... %			
No. 0 adapted for Rat or Gopher, No. 1 for Muskrat, and No. 1½ for Mink.					No. 2 adapted for Fox, No. 3 for Otter, No. 4 for Beaver.			

NEWHOUSE BEAR TRAPS



No. 5—With Chain, Weight 18 lbs., Spread of Jaws 11½ inches..... per doz.	\$140.00
Extra Springs for No. 5 Bear Traps..... “	30.00

Bear Trap Clamps, see page 76.

SKATES



Nos. 5 to 10

- | | | |
|---|----------|--------|
| No. 5—Halifax Pattern, Steel Runners, Curved, Ordinary Finish, Sizes 7 to 12 inch | per pair | \$0.66 |
| " 9— " " " " Full Nickel-Plated and Polished, Sizes 8 to 12 inch | " | 1.30 |
| " 7—Henry Boker's Halifax Pattern, Best Quality Welded and Tempered Steel Runners, Curved, Fine Finished, Sizes 7½ to 12 inch | " | 1.30 |
| " 10—Henry Boker's Halifax Pattern, Best Quality Welded and Tempered Steel Runners, Full Nickel-Plated and Polished, Sizes 8 to 12 inch | " | 1.30 |

No. 41



No. 12

- | | | |
|---|----------|------|
| No. 12—Henry Boker's Halifax Pattern, Best Quality Welded and Tempered Steel Runners, Curved, Concave, Full Nickel-Plated and Polished, Sizes 9 to 11½ inch | per pair | 3.20 |
|---|----------|------|

No. 457



No. 401 and 402

- | | | |
|--|----------|------|
| No. 401—Henry Boker's Victoria Club, Best Quality Welded and Tempered Steel Runners, Curved, Fine Finished, Sizes 8½ to 11¼ inch | per pair | 1.20 |
| " 402—Henry Boker's Victoria Club, Best Quality Welded and Tempered Steel Runners, Curved, Full Nickel-Plated and Polished, Sizes 8½ to 11¼ inch | " | 2.20 |

No. 115B



No. 411 and 412

- | | | |
|--|----------|------|
| No. 411—Henry Boker's Crescent, Best Quality Welded and Tempered Steel Runners, Curved, Fine Finished, Improved Top Plates, Sizes 8 to 12 inch | per pair | 1.10 |
| " 412—Henry Boker's Crescent, Best Quality Welded and Tempered Steel Runners, Curved, Full Nickel-Plated and Polished, Improved Top Plates, Sizes 8 to 11 inch | " | 2.20 |

No. 115BD

SKATES



No. 414

No. 414—Henry Boker's Beauty, Best Quality Welded and Tempered Steel Runners, Curved, Concaved, Full Nickel-Plated and Polished, Improved Top Plates, Sizes 8 to 11½ inch. per pair \$2.70



No. 457P

No. 457P—Henry Boker's, Pride, Extra Extra Quality Welded and Tempered Steel Runners, Curved, Full Nickel-Plated and Polished, with Improved Pattern Polished Top Plates (right and left) and Patented Cup Brackets, especially designed for fancy skating, Sizes 8 to 11½ inch. per pair 4.20



No. 115B

No. 115B—Henry Boker's, Ideal, Extra Extra Quality Welded and Tempered Steel Runners, Curved, Concaved, Full Nickel-Plated and Polished, with Polished Top Plates (Handsome Gents' Skates), Sizes 10½ to 12 inch. per pair 5.20



No. 115BD

No. 115BD—Henry Boker's, Ideal, Extra Extra Quality Welded and Tempered Steel Runners, Curved, Full Nickel-Plated and Polished, with Polished Top Plates (Handsome Ladies' Skates) Sizes 8½ to 10 inch per pair 5.20

HOCKEY SKATES



Nos. 510 and 511

- No. 510—Hockey, Steel Runners, Straight, Ordinary Finish, Improved Top Plates, 7½ to 12 inch... per pair \$0.70
 " 511—Henry Boker's, Hockey, Best Quality Welded and Tempered Steel Runners, Straight, Fine Finished, Improved Top Plates, Sizes 8 to 12 inch..... per pair 1.45



Nos. 531 and 532

- No. 531—Henry Boker's, Royal Hockey, Best Quality Welded and Tempered Steel Runners, Straight, Fine Finished, with Improved Pattern Blued Top Plates, and Patented Cup Brackets, Sizes 8 to 12 inch..... per pair 1.55
 " 532—Henry Boker's, Royal Hockey, Best Quality Welded and Tempered Steel Runners, Straight, Full Nickel-Plated and Polished, with Improved Pattern Top Plates, and Patented Cup Brackets, Sizes 9 to 12 inch..... per pair 2.30



Nos. 536 and 537

- No. 536—Henry Boker's, Imperial Hockey, Extra Extra Quality Welded and Tempered Steel Runners, Straight, Fine Finished, Improved Pattern Black Rust-Proof Steel Top Plates (Right and Left) with Patented Cup Brackets, Sizes 9 to 12 inch..... per pair 2.50
 " 537—Henry Boker's, Imperial Hockey, Extra Extra Quality Welded and Tempered Steel Runners, Straight, Full Nickel-Plated and Polished, Improved Pattern Top Plates (Right and Left) with Patented Cup Brackets, Sizes 9 to 12 inch..... per pair 3.10



No. 631

- No. 631—Henry Boker's, Perfect Hockey, Best Quality Welded and Tempered Steel Runners, Straight, with Puck Stopper, Fine Finished, with Blued Improved Tops and Patented Cup Brackets, Sizes 9 to 12 inch..... per pair 1.62

HOCKEY SKATES



No. 636

No. 636—Henry Boker's, Majestic Hockey, Extra Extra Quality Welded and Tempered Steel Runners, Straight, with Puck Stopper, Fine Finished, with Improved Pattern Black Rust-Proof Steel Top Plates (Right and Left) and Patented Cup Brackets, Sizes 10 to 12 inch.....per pair = \$3.00



No. 549

No. 549—Henry Boker's, Ice King, Extra Extra Quality Welded and Tempered Steel Runners, Straight, Concaved, Full Nickel-Plated and Polished, with Improved Pattern Top Plates (Right and Left) and Patented Cup Brackets, Sizes 10 to 12 inch.....per pair = 3.00



No. 597

No. 597—Henry Boker's, Double End Hockey, Extra Extra Quality Welded and Tempered Steel Runners, Straight, Full Nickel-Plated and Polished, with Improved Pattern Top Plates, Sizes 9½ to 12 inch.....per pair 4.50



No. 566

No. 566—Henry Boker's, Special Racer, for Racing and Hockey Players of Light Weight, Extra Extra Quality Welded and Tempered Steel Runners, Light, Straight, Fine Finished, with Improved Pattern, Black Rust-Proof Steel Top Plates (Right and Left) and Patented Cup Brackets, Sizes 10 to 12 inch.....per pair 3.50



Cuts Illustrating Henry Boker's Patented Cup Brackets.

RACING SKATES



No. 567VP

No. 567VP—Henry Boker's Unrivalled Racer, Extra Extra Quality Welded and Tempered Steel Runners, Very Light, Straight, Bevelled, Full Nickel-Plated and Polished, with Improved Pattern Top Plates, (Right and Left), and Patented Cup Brackets, Sizes 9 to 12 inch..... per pair \$5.50



No. 117B

No. 117B—Henry Boker's Russian Racer, Extra Extra Quality Welded and Tempered Steel Runners, Straight, Bevelled, Full Nickel-Plated and Polished, with Polished Top Plates, Sizes 10½ to 11½ inch..... per pair 8.30

BOKER'S TUBE SKATES



Nos. 116 and 116B

No. 116—Long, Henry Boker's Norwegian Racer, Extra Extra Quality Steel Runners, Reinforced Steel Tube Pattern, Aluminum Finish, Sizes 10 to 11½ inch..... per pair 8.90
 No. 116B—Long, Henry Boker's Norwegian Racer, Extra Extra Quality Steel Runners, Reinforced Steel Tube Pattern, Full Nickel-Plated and Full Polished, Sizes 10 to 11½ inch..... " 11.60

FISHER'S TUBE SKATES

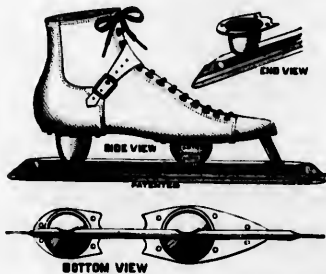

RACING OR GENERAL PURPOSE SKATE



HOCKEY SKATE

Regular, Racing or Hockey Skates, Sizes 9 to 12 inch..... per pair 9.00
 Shoes..... 4.20

These Skates are made entirely of Steel, Nickel-Plated, in both ladies and gents sizes. The blade of the Regular or Racing Skate, 12 to 17 inches long, ¼ to ⅜ inch thick. Hockey 11 to 14 inches long, ⅜ inch thick. In ordering skates size should be specified in inches from tip to tip of toe and heel plates. 14 inch blades are recommended for regular use or racing purposes in small rinks.

No. 0—
 " 3—
 " 7—
 " 10—

No. 5—B
 " 7—B
 " 10—F

Lugs.....
 Screws.....
 Nuts.....
 Wrenches.....
 Links.....
 Levers.....
 Heel Butts

Russett, Ex
 " No
 Black, Ext

No. XXX—
 " XX—
 " XX—
 " XX—
 " X—
 " X—
 " O—

Regulation S

SKATES

THE STARR MANUFACTURING CO. S



GENUINE ACME CLUB

No. 0—Made throughout of Steel, but not so highly finished as the better grades, Sizes 7 to 12 inch	per pair	\$0.75
" 3—Nickel-Plated, same quality and finish as No. 0, Sizes 7½ to 12 inch	"	1.35
" 7—Blades of Extra Quality Welded Steel, Tempered, Tops of Extra Quality Crucible Steel, Oxidized, Blades and Edges of Tops are Finely Finished, Sizes 8 to 12 inch	per pair	3.80
" 10—Full Nickel-Plated on Copper, Identical with No. 7, Runners and Edges of Tops Burnished, Sizes 8 to 12 inch	per pair	5.10



STARR HOCKEY SKATE

No. 5—Blades of Best Cast Steel, Highly Finished Tops, Carbonized Steel, Oxidized, Sizes 9 to 12 in	per pair	1.70
" 7—Blades of Extra Quality Welded Steel, Tempered, Tops of Extra Quality Crucible Steel, Oxidized, Blades and Edges of Tops are Finely Finished, Sizes 9 to 12 inch	per pair	3.00
" 10—Full Nickel-Plated on Copper, Identical with No. 7, Runners and Edges of Tops Burnished, Sizes 9 to 12 inch	per pair	4.40

EXTRA PARTS FOR SPRING SKATES

Lugs	per doz	0.40
Screws	"	0.24
Nuts	"	0.24
Wrenches	"	0.32
Links	"	0.100
Levers	"	1.02
Heel Buttons	"	0.48

SKATE STRAPS

Russett, Extra, 21 x ½ inch	per gross	15.75
" " 36 x ½ "	"	30.00
" No. 1, 21 x ½ "	"	13.25
Black, Extra, 21 x ½ "	"	18.00

HOCKEY STICKS

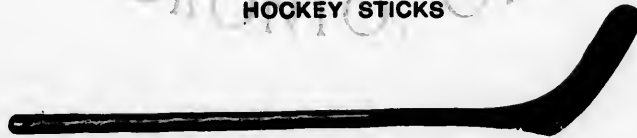

No. XXX—Rock Elm, Plain Finish	per doz.	5.90
" XX— " Oiled	"	6.00
" XX— " Plain Finish	"	3.70
" XX— " Oiled	"	4.50
" X—Boy's, Plain Finish	"	2.90
" X— " Oiled	"	3.00
" O— " Plain	"	2.35

HOCKEY PUCKS

Regulation Size, Diameter 3 inches, Thickness 1 inch, Weight ½ lb.	per doz.	4.50
--	----------	------

NO. 1370

FISH HOOKS

SPROAT TAPERED HOOKS

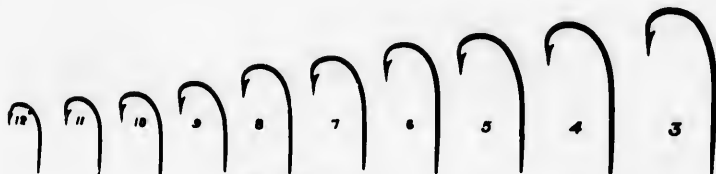

No. 2544

Size Nos.....	12 to 1	1-0	2-0	3-0	
No. 2544.....	per 1,000	\$1.15	1.45	1.65	1.90

CARLISLE FISH HOOKS

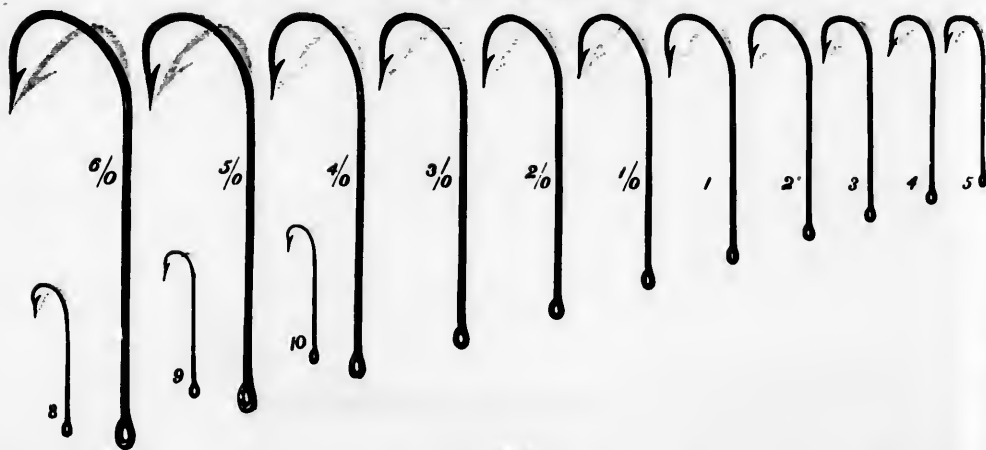

No. 2613

Size Nos.....	12 to 1	1-0	2-0	3-0	4-0	5-0	6-0	
No. 2613—Ringed.....	per 1,000	\$1.00	1.25	1.45	1.70	1.95	2.15	2.25
" 2614—Marked.....	"	1.00	1.25	1.45	1.70

KIRBY AND LIMERICK FISH HOOKS, RINGED

Size Nos.....	12 to 1	1-0	2-0	3-0	4-0	5-0	6-0	7-0	8-0	9-0	10-0
No. 1939—Kirby Bend... per 1,000	\$0.63	0.80	1.00	1.15	1.30	1.50	1.90	2.45	3.20	4.15	5.00
" 1937—Limerick.....	"	0.63	0.80	1.00	1.15	1.30	1.50	1.90

One hundred in a box.

Size Nos...
No. 375—
" 376—

Size Nos...
No. 377—
" 378—

Size Nos...
No. 379—
" 380—

Size Nos...
No. 381—
" 382—

Size Nos...
No. 383—
" 384—

Size Nos...
No. 385—

Size Nos...
No. 386—

SNELLED FISH HOOKS

NO 307

SNECK HOOKS

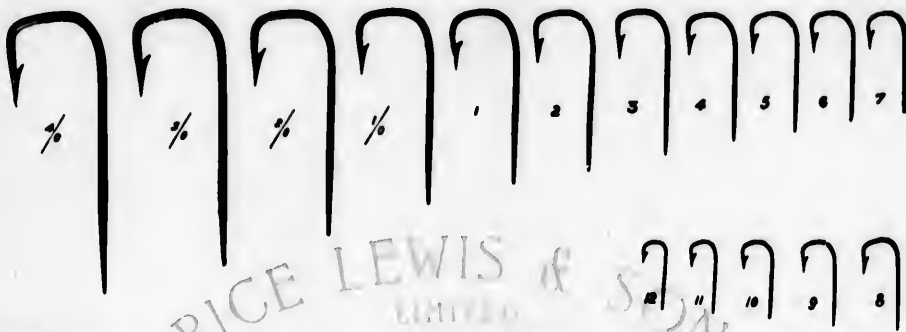

Size Nos.....	6 to 2	1	1-0	2-0	3-0	4-0
No. 375—Single Gut..... per gross	\$1.70	1.70	2.20	2.50	3.00
" 376—Double Gut.....	2.95	3.40	3.85	4.35	4.85

LIMERICK HOOKS

Size Nos.....	6 to 2	1	1-0	2-0	3-0	4-0
No. 377—Single Gut..... per gross	\$1.70	1.70	2.20	2.50	3.00
" 378—Double Gut.....	2.95	3.40	3.85	4.35	4.85

CARLISLE HOOKS

Size Nos.....	10 to 2	1	1-0	2-0	3-0	4-0	5-0	6-0
No. 379—Single Gut..... per gross	\$1.70	1.70	2.20	2.50	3.00
" 380—Double Gut.....	2.95	3.40	3.85	4.35	4.85	5.40	6.25

ABERDEEN HOOKS

Size Nos.....	10 to 1	1-0	2-0	3-0	4-0	5-0	6-0
No. 381—Single Gut..... per gross	\$1.70	2.20	2.50	3.00
" 382—Double Gut.....	3.40	3.85	4.35	4.85	5.40	6.25

SPROAT HOOKS

Size Nos.....	10 to 2	1	1-0	2-0	3-0
No. 383—Single Gut..... per gross	\$1.70	1.70	2.20	2.50
" 384—Double Gut.....	2.95	3.40	3.85	4.35

LIMERICK HOOKS, ON GIMP

Size Nos.....	1-0	2-0	3-0	4-0	5-0	6-0
No. 385..... per gross	\$1.75	5.05	5.35	5.65	5.95	6.25

TREBLE HOOKS, RINGED

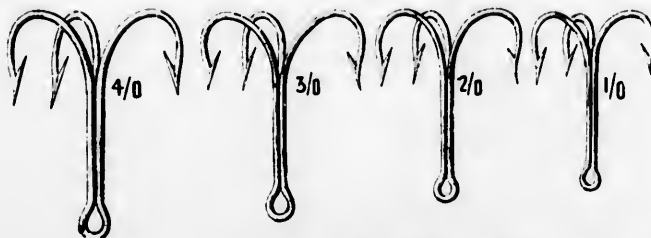

Size Nos.....	6 to 1	1-0	2-0	3-0	4-0	5-0	6-0	7-0
No. 386—Bright..... per gross	\$2.05	2.40	2.55	2.70	3.05	3.70	4.40	5.40

Quarter gross in a box.

3-0
1.90

6-0
2.25

9-0 10-0
4.15 5.00

1/2 doz

TROUT FLIES



**ALDER
JOCK SCOTT
SILVER DOCTOR LIGHT
CHANTRY**



**WATER CRICKET
LALA
SILVER DOCTOR DARK
WREN TAIL**



**BLACK PALMER
GREY DRAKE
PARMACHENE BELL
QUEEN OF WATERS**

**BROWN PHEASANT
PROFESSOR
ALEXANDRIA
SOLDIER PALMER**

Trout Flies on Single Gut..... per doz. \$0.35
Midget " " "..... " 0.80

BASS FLIES



**BLUE TURKEY
GREY PALL**



**BROWN PHEASANT
GRIZZLY KING**



**GREEN DRAKE
FURNACE PALMER**

**RUBE WOOD
ETC., ETC.**

On Single Gut..... per doz. \$0.90
On Double Gut..... " 1.10

FLY BOOKS

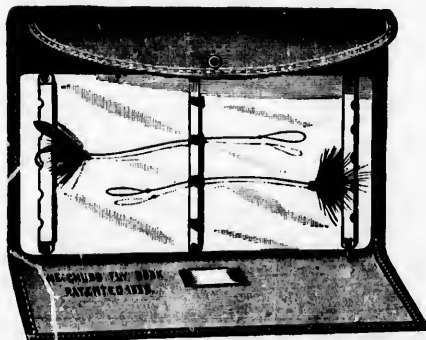

- | | |
|---|----------|
| | Per doz. |
| No. 1—Size, 6½x3½, Leather Covers, Cloth Lined, 1 Pocket in Cover, Parchment Leaves, Bound with Leatherine, 2 Paper Pockets, holds 2 dozen Flies | \$ 7.60 |
| " 2—Size, 6½x3½, Leather Covers, Cloth Lined, 1 Pocket in Cover, Parchment Leaves, Bound with Leatherine, 2 Paper Pockets, holds 3 dozen Flies | 13.65 |
| " 3—Size, 7½x3½, Leather Covers, Leather Lined, 2 Pockets in Covers, Parchment Leaves, Bound with Leatherine, 2 Paper Pockets, holds 4 dozen Flies | 21.25 |
| " 4—Size, 7½x4, Leather Covers, Leather Lined, 2 Pockets in Covers, Parchment Leaves, Bound with Leatherine, 2 Paper Pockets, holds 6 dozen Flies | 34.20 |
| " 5—Size, 7½x4, Fine Leather Covers, 1 Pocket, Waterproof Leaves, Fine Flannels for protecting and drying Flies, holds 6 dozen Flies..... | 38.00 |
| " 6—Size, 7½x4, Best Morocco Covers, 2 Pockets, Waterproof Leaves, Fine Flannels for protecting and drying Flies, holds 6 dozen Flies..... | 53.00 |
| " 9—Size, 7x3½. This is a Combination Fly and Tackle Book, and is very handy; has Fine Black Leather Covers, with 4 Large Pockets and 3 Small Ones; Parchment Leaves for holding Flies, Bound with Leatherine; holds 2 dozen Flies..... | 20.25 |
| No. 12—Size, 11x3½. This is a Combination Fly and Hook Book, made long enough to hold Snelled Hooks, with the Snells straight; Leather Covers with 2 Snap Locks, Cloth Lined, 1 Large Pocket, has Stiff Leaves, and holds 2 dozen Flies and 4 dozen Snelled Hooks, and all fastened separate..... | 30.40 |
| " 13—Size, 6½x3½. New style and new method of holding Flies, no Springs, yet each Fly held separate; Black Seal Grain Covers; very neat, light, durable Book, designed especially for Anglers who wish to keep their Flies separate from their Snelled Hooks and other Tackle, and do not wish to carry a large Book of Flies while on the stream. Holds 4 dozen Flies..... | 16.75 |



FLUT

Size Nos.
Fluted Ba
Pickerel B
Size Nos.
Coburg B
Size Nos.
Diamond C
Size Nos.
Allure, Nic

11/21/2009

TROLLING BAITS

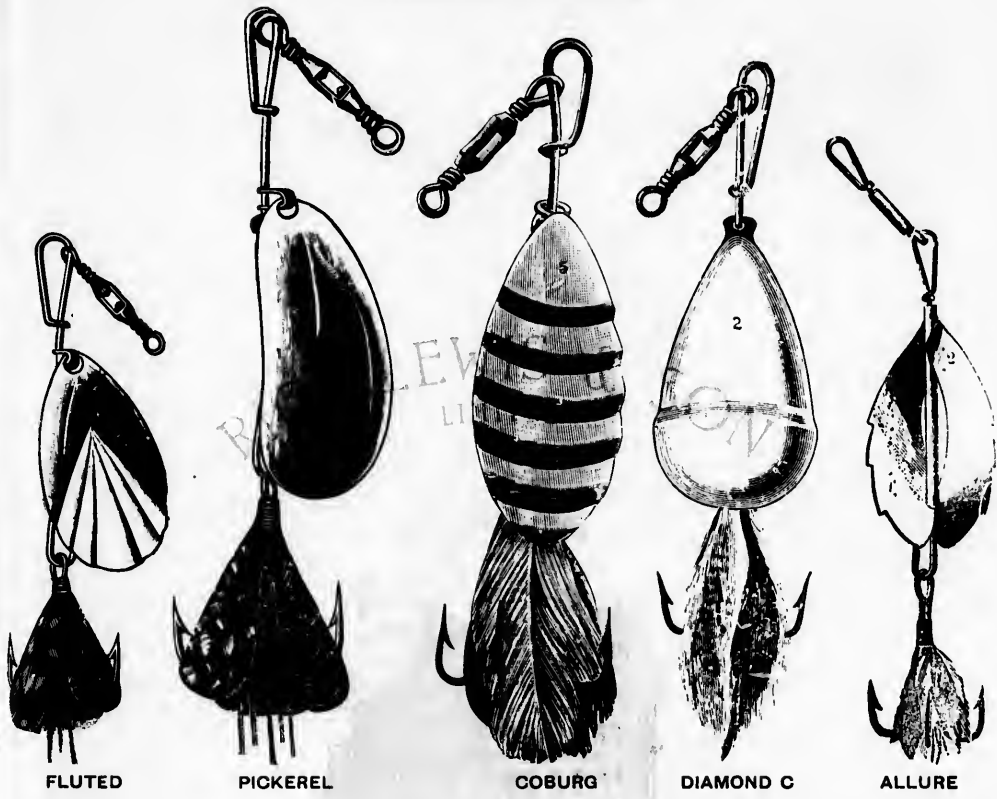

	4	4 1/4	5	6	7	8
Size Nos.	4	4 1/4	5	6	7	8
Fluted Bait, Nickel-Plated per doz.	\$1.15	1.15	1.15	1.15	1.15	1.15
Size Nos.	4	4	5	6	7	7
Pickrel Bait, Nickel-Plated per doz.	\$1.05	1.05	1.05	1.05	1.05	1.05
Size Nos.	3	4	5	6	7	8
Coburg Bait, Nickel-Plated per doz.	\$1.25	1.25	1.25	1.25	1.25	1.25
Size Nos.	3	2	3	2	1	1/2
Diamond C, Nickel-Plated, Gold End per doz.	\$4.00	4.00	4.00	4.00	4.00	4.70
Size Nos.	3	2	1	1/2	3/4	2/3
Allure, Nickel and Brass per doz.	\$7.40	7.40	7.40	8.10	8.10	8.10

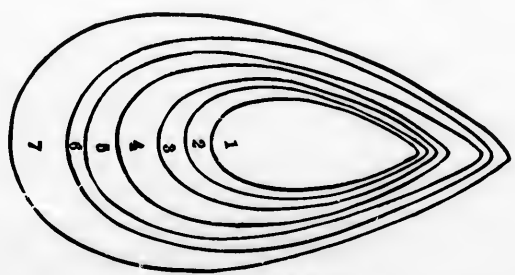

Scale for sizes of Spoons.
1028

HEASANT
OR
RIA
PALMER
doz. \$0.35
" (0.80)

UBE WOOD
TC., ETC.
doz. \$0.90
" 1.10

Per doz.
Poc-
with
Flies \$ 7.60
Poc-
with
Flies 13.65
2 Poc-
with
Flies 21.25
2 Poc-
with
Flies 34.20
Water-
g and 38.00
Water-
g and 53.00
ackle
ather
Ones ; 20.25
ooks,
s Stiff 30.40
rate ;
s who
ish to 16.75

NOV 21

TROLLING BAITS



FINE MUSKALLONGE

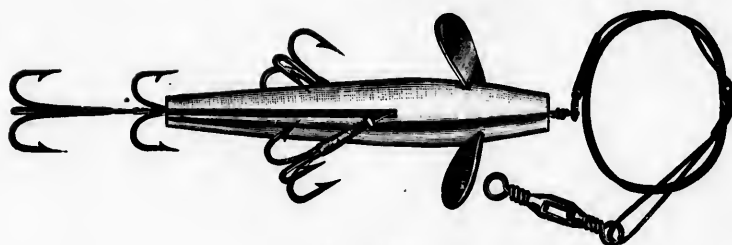

DEVON BAIT

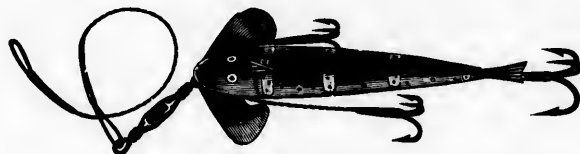

PHANTOM MINNOW



CASTING SPOON

FINE MUSKALLONGE

Nos.....	1	2	3	4
Nickel Convex, Copper Concave..... per doz.	\$2.65	3.30	5.30	6.80

OVAL HAMMERED

For style see Luminous Ohio Hammered, page 1023.

Nos.....	1	2	3	4	6
Per dozen.....	\$1.05	1.05	1.05	1.05	1.05

DEVON BAITS

Nos.....	2	3	5	7
Size.....	1½	2	2½	3 inch.
1260—English, Assorted Colors, 1st Quality .. per doz.	\$4.90	5.40	6.00	6.00
Nos.....	1	2	3	4
Size.....	2	2½	2½	2½ inch.
American, Assorted, Nickel and Gilt. per doz.	\$4.70	4.70	4.70	4.70

PHANTOM MINNOWS

Nos.....	1	2	3	4	6	8
Size.....	1½	2	2½	3	4	4½ inch.
Assorted Colors..... per doz.	\$6.45	6.45	6.45	6.45	7.50	10.00

CASTING SPOONS

Nos.....	15	18
Spreat Hooks with Double Gut Loop..... per doz.	\$0.90	1.30

NOV 27

LUMINOUS TROLLING BAITS

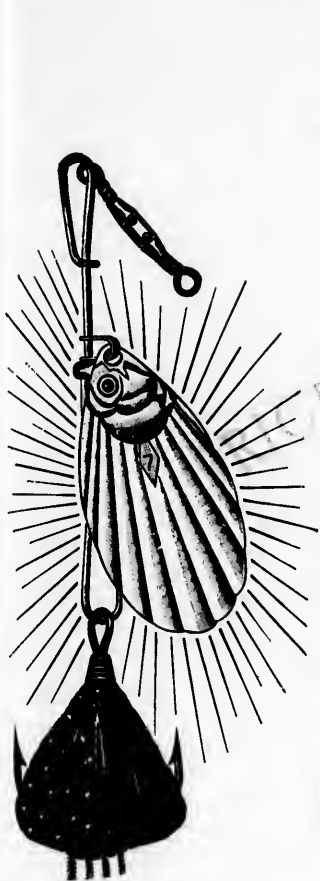

SUCCESS



CRESCENT, No. 4



CRESCENT, No. 2

SUCCESS

Nos.....	1	3	5	7	9	11	13
Per dozen.....	\$3.50	3.50	4.25	4.25	5.30	6.35	6.35

CRESCENT

Nos.....	1	2	3	4	5	6
Per dozen.....	\$4.65	4.65	4.65	6.00	6.00	6.00

FINE MUSKALLONGE

For Style, see Fine Muskallonge, page 1024.

Nos.....	1	2	3	4
Per dozen.....	\$3.30	4.25	6.00	8.70

NEW AKRON

Nos.....	1	2
Per dozen.....	\$4.35	5.20



IG SPOON

3	4
5.90	6.00

4	6
1.05	1.05

7
3 inch.
6.00

4
2 1/2 inch.
4.70

8
4 1/2 inch.
10.00

15	18
9.90	1.90

NOTES

LUMINOUS TROLLING BAITS



HOLT'S MUSKALLONGE



OHIO HAMMERED



AMERICAN SPINNER, No. 3

HOLT'S MUSKALLONGE

Nos.	6	7	8
Plain or Hammered	per doz. \$5.30	4.20	7.00

OHIO HAMMERED

Nos.	1	3	4	6	8
Per dozen	\$3.20	3.70	3.70	4.20	5.30

AMERICAN SPINNER

Nos.	1	3	4	5	8
Per dozen	\$3.10	3.10	3.10	3.10	3.10

IRVIN, F.

Nos.
Per dozen

Nos.
Per dozen

Nos.
Per dozen

Nos.
Per dozen

LUMINOUS TROLLING BAITS



GOVERNOR



IRVIN, No. 6



PHANTOM MINNOW
GOVERNOR

Nos.....	7	8	9
Per dozen.....	\$8.45	9.50	10.50

IRVIN

Nos.....	1	2	3	4	5	6
Per dozen.....	\$3.20	3.20	3.20	3.70	3.70	3.70

PHANTOM MINNOWS

Nos.....	0	1	1½	2	3	5	8
Per dozen.....	\$9.70	9.70	9.70	9.70	9.70	10.50	12.90

LUMINOUS TROUT SPINNERS



No. 9

Nos.....	9	2	208
Per dozen.....	\$2.35	4.75	2.95



MINNER, No. 3

7	8
6.20	7.00
6	8
4.20	5.30
5	8
3.10	3.10

NA 276

FURNISHED FISH LINES



No. 4—Composed of 1 1/2 inch Float, 15 feet Drab Cotton Line, Ringed Hook, Sinker, Wood Winder, per doz. \$0.55

FISH LINES

DRAB COTTON						
15 feet Hanks, Connected.						
Nos.....	2	3	4	5		
Per gross.....	\$1.10	1.25	1.40	1.65		
ECRU COTTON						
25 feet Blocks, 4 Connected.						
Nos.....	1	2	3	4	5	
Per dozen	\$0.50	0.54	0.57	0.60	0.63	
ECRU COTTON						
50 feet Blocks, 4 Connected.						
Nos.....	1	2	3	4		
Per dozen	\$0.75	0.80	0.85	0.90		
SEA ISLAND WATERPROOF COTTON						
50 feet Coils, 2 Connected.						
Nos.....				63	65	
Per dozen.....				\$0.80	1.00	
BRAIDED COTTON						
84 feet Hanks, 2 Connected.						
Nos.....	6	5	4	3	1	0 00
Per dozen.....	\$1.25	1.25	1.25	1.25	1.50	1.65 1.95

LINEN LAID			
50 feet Coils, 3 Connected.			
Nos.....	6-35	12-35	15-35
Per dozen.....	\$1.50	2.15	2.50
BRAIDED LINEN			
25 yard Blocks, 4 Connected.			
Nos.....	5	4	3
Per 100 yards.....	\$0.70	0.70	0.70
FINISHED SILK, No. 105			
25 yard Blocks, 4 Connected.			
Nos.....		5	3
Per 100 yards.....		\$1.30	2.15
BRAIDED SILK, "HERCULES"			
25 yards, 4 Connected.			
Nos.....	5	4	3
Per 100 yards.....	\$1.95	2.25	2.60
ENAMELLED SILK (ENGLISH)			
25 yards, 4 Connected.			
Nos.....	6	4	2
Per 100 yards.....	\$3.25	4.40	5.30

GUT CASTING LEADERS

Length.....		1	2	3 yards.
No. 058—Single Gut, Common.....	per doz.	\$0.32	0.65	1.00
" 258— " Best.....	"	0.80	1.60	2.40
" 488—Double Gut, Medium Quality.....	"	1.30	2.60	3.00
" 568— " Very Strong.....	"	2.00	5.20	7.80



WOOD TROLLING LINE REELS

No. 2—Medium Size, with Patent Brake, Assorted Colors, Reels only.....	per doz.	\$1.40
No. 3—Large Size, with Patent Brake, Assorted Colors, Reels only.....	per doz.	1.65

FISHING REELS

NO 2073

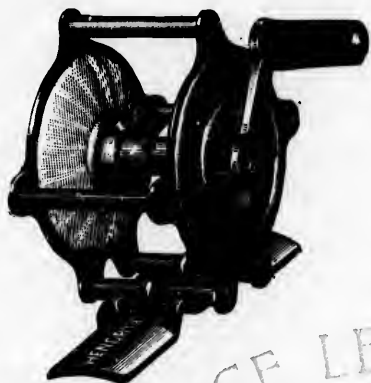

No. 1028

Single Action, Raised Pillar, Riveted Brass Reel.

Nos.....	102P	106P
Capacity.....	25	60 yards.
Per dozen.....	\$1.70	2.25

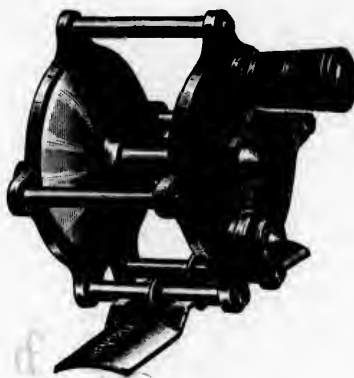

No. 00304

Single Action, Raised Pillar, Screwed Brass Reel, with Flush Balance Handle and Back Sliding Click, Nickel-Plated.

Nos.....	00304PN	00306PN	00307PN
Capacity.....	40	60	80 yards.
Per dozen....	\$6.85	7.45	8.00

Single Action, Raised Pillar, Riveted Brass Reel, with Click, Nickel-Plated.

Nos.....	204PN	206PN
Capacity.....	40	60 yards.
Per dozen.....	\$3.40	3.70

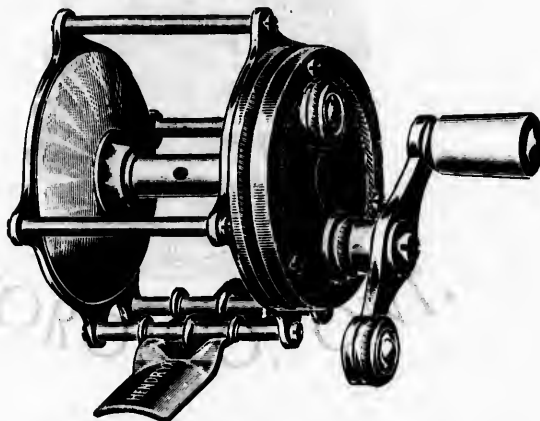

No. 987PN

Double Multiplying, Raised Pillar, Balance Handle, Screwed Brass Reel, with Fine Steel Pivots and Brass Bushed Bearings, Patent Adjustable Slide Drag, Back Sliding Click.

No. 986PN —60 yards, Nickel-Plated.....	per doz.	\$21.00
" 987PN —80 " "	"	24.30
" 988PN —100 " "	"	27.85

Double Multiplying, Raised Pillar, Balance Handle, Screwed Brass Reel, with Patent Adjustable Slide Drag, and Back Sliding Click.

No. 9904PN —40 yards, Nickel-Plated.....	per doz.	\$ 9.60
" 9906PN —80 " "	"	10.50
" 9907PN —80 " "	"	11.40
" 002904PN —40 " " with Rubber Cap.....	"	12.00
" 002906PN —60 " "	"	13.00
" 002907PN —80 " "	"	14.00
" 002908PN —100 " "	"	15.50

per doz. \$0.55

12-35 15-35
2.15 2.50

ed. 5 70 0.70 0.70 3

ed. 5 3
\$1.30 2.15

LES"

5 4 3
1.95 2.25 2.60

LISH)

6 4 2
3.25 4.40 5.30

2 3 yards.
0.65 1.00
1.60 2.40
2.60 3.00
5.20 7.80

LING LINE
LS

with Patent
orted Colors,
per doz. \$1.40

with Patent
orted Colors,
per doz. 1.65

№ 570

FISHING REELS

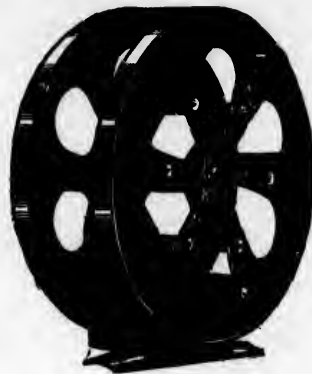

EXPERT

With Back Sliding Click and Patent Guard Band, which also forms Stop and Drag, made of Best Spring Steel and operated with the thumb by pressure, the best all round Reel in the market.

- No. 19—40 yards, Nickel-Plated.....per doz. \$29.15
 " 17—100 " " " 31.00

AMATEUR

Same style as Expert, but without the Spring Band.

- No. 12—40 yards, Nickel-Plated.....per doz. 21.85

FEATHER LIGHT

Removable Spool, Back Sliding Steel Click, Steel Spindle, Lightest Reel made.

- No. 260—40 yards, Nickel-Plated.....per doz. 21.85
 " 270—60 " " " 25.50

MARTIN'S STANDARD AUTOMATIC REELS

This Reel is automatic. Main Spring can be wound or unwound without touching line by turning Main Spring Drum, thereby rendering any tension desired on long or short line. The Endless Spring making it both desirable and durable. Has capability of Main Spring, being readily and easily adjusted to greater or less tension at any time during the operation of landing a fish.

- No. 1—Creek Whipper Line Spool is 2½ inches in diameter, with ¾ Hub and ¼ wide, will hold 25 yards of Medium Line, each \$7.00
- " 2—Fly Casting, has the same diameter of Line Spool and Hub, but is ⅝ wide, having a capacity for 25 yards of Casting-Line each 7.00
- " 3—Bass Reel. Line Spool is 2½ inches in diameter, Hub ¾, and width ¾ inches will hold 50 yards. For "Bass" this is the "real" thing.....each 8.00
- " 4—Salmon Reel. Has a Line Spool 2½ inches in diameter, Hub ¾ inch in diameter, and the width is ⅞ giving space for 50 yards of Large Line. Automatic for 100 feet....each 9.00



MARTIN.
 TURN MAIN SPRING
 DRUM TO RIGHT.
PATENTED JULY 26, 1882 DEC. 17, 1885. PATENT PENDING.

No. 4 -
 " 4A -
 " 4B -
 " 4C -
 " 8 -
 " 8A -
 " 8B -
 " 8C -
 " 16 -
 " 16A -
 " 17 -

No. 25 -
 " 25N -
 " 25A -
 " A12 -
 " A15 -
 " D12 -
 " D15 -
 " N12 -
 " N15 -
 " 12 -
 " 15 -

No. 361 - F
 " 461 - F

No. X85 - F
 " X85 - F
 " 485 - C

FISHING RODS

1102078

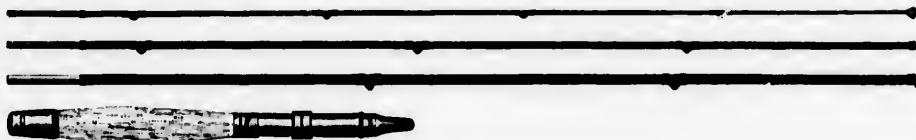

STEEL BAIT ROD, CORK GRIP

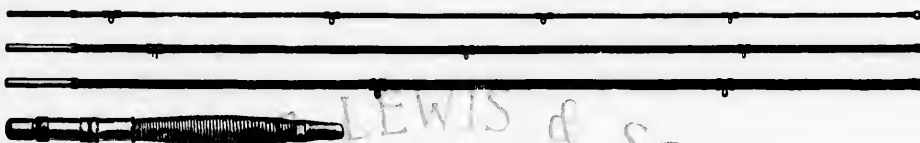

STEEL FLY ROD, CELLULOID GRIP

STEEL RODS

No. 4	—Bass Rod, 10 feet in Length, Nickel Mountings, Cork Grip.....	each	\$ 8.50
" 4A	— " " 10 " " " " " " " " " " " "	"	7.70
" 4B	— " " 10 " " " " " " " " " " " "	"	9.05
" 4C	— " " 10 " " " " " " " " " " " "	"	8.85
" 8	—Fly Rod, 10 " " " " " " " " " " " "	"	8.50
" 8A	— " " 10 " " " " " " " " " " " "	"	7.70
" 8B	— " " 10 " " " " " " " " " " " "	"	8.85
" 8C	— " " 10 " " " " " " " " " " " "	"	9.05
" 16	— " " 9 " " " " " " " " " " " "	"	7.70
" 16A	— " " 9 " " " " " " " " " " " "	"	8.50
" 17	—Bait Casting Rod, 7 feet in Length, Nickel Mountings, Cork or Cane Wound Grip.....	"	10.00

SPLIT BAMBOO RODS

No. 25	—Chubb's, 6 Strip, German Silver Trimmings, 10½ ounces.....	each	25.25
" 25N	— " " 6 " " Nickel-Plated " " 10½ " " " " " " " " " "	"	21.35
" 25A	— " " 8 " " German Silver " " 10½ " " " " " " " " " "	"	29.10
" A12	—Fly Rod, Best Quality, 6 Strip, Cedar, Inlaid Swelled Butt, German Silver Mountings, Cork Grasp, Silk Wrappings, Welt Ferrules, 3 Joints, Extra Tip, 9½ to 10 ft.....	each	7.60
" A15	—Bait Rod, otherwise same as A12, 9½ to 10 ft.....	"	7.60
" D12	—Fly Rod, 6 Strip Rod, Nickel Mountings, Solid Reel Seat, Cork Grip, 9½ to 10 ft.....	"	4.65
" D15	—Bait Rod, 6 " " " " " " " " " " " "	"	4.65
" N12	—Fly Rod, 6 " " " " " " " " " " " "	"	2.75
" N15	—Bait Rod, 6 " " " " " " " " " " " "	"	2.75
" 12	—Fly Rod, 6 " " " " " " " " " " " "	"	1.75
" 15	—Bait Rod, 6 " " " " " " " " " " " "	"	1.75

GREENHEART RODS

No. 36½	—Fly Rod, Solid Reel Seat, Improved Shouldered Ferrules, Silk Wrappings, Scored Wood Grip, 10 ft.....	Each	3.50
" 46½	—Bait Rod, "	10 ft.	3.50

LANCEWOOD RODS

No. X65	—Fly Rod, Full Nickel Mounted, Raised Ferrules, Silk Whippings, Scored Grip, 10 ft.....	each	2.05
" X95	—Bait Rod, "	10 ft.	2.05
" 495	—Combination Rod, 3-Joint Heavy Bait Rod, 10½ feet, weight 15 ounces, or a 2-Joint Trolling Rod, 7 feet, weight 13 ounces, Full Nickel Mountings, Solid Reel Seat, Silk Wound Tee Guides, Celluloid Grip above and below Reel Seat.....	each	4.05

Steel and

\$29.15
31.00

21.85

21.85
25.50

T BENDING

NO 2070

FISHING RODS

TRUNK RODS

No. 610—6 pieces, Ash Butt, Lancewood Tip, Fine Finished Guides and Reel Bands..... per doz. \$18.25

FOUR-JOINT BAIT RODS

No. 421½ —Fine Polished Brass Mountings, Hollow Butt, Lancewood Tip and Short Tip, 11 ft..... per doz. 19.70
 " 420N—Nickel Mountings, Light Color Finish, Scored Wood Butt, 11 ft..... " 18.00
 " 418 —Brass Mountings, Dark Color, Reel Band and Butt Cap, 11 ft..... " 10.80

THREE-JOINT BAIT RODS

No. 329½ —Brass Mountings, Dark Color, Ironwood Tip, Rings, Reel Bands, Hollow Butt, 10½ ft... per doz. 16.85
 " 329 — " " " " " and Butt Cap, 10½ ft... " 13.50
 " 320HB— " " " " " Lancewood Tip " " Hollow Butt, 9 to 10 ft. " 14.85
 " 318F — " " " " " Light Color " " Butt Cap, 9 to 10 ft... " 10.80
 " 318 — " " " " " Dark Color " " " " " " " 8.10
 " 3/0 — " " " " " Rings and Reel Bands..... " 4.20
 " 1 — " " " " " Single Ferrules, Light Color..... " 2.00

JOINTED BAMBOO RODS

No. X5 —4 Joint Double Ferrules, Band Guides, Reel Bands, 14 ft..... per doz. 12.80
 " X30—3 " " " " " 10½ ft..... " 8.75
 " 73—3 " " " " " Rings and Reel Bands and Butt Cap, 12 to 14 ft..... " 9.45
 " 71—3 " " " " " Rings and Butt Cap, 12 to 14 ft..... " 5.40
 " 70—2 " " with Rings, 9 to 10 ft..... " 2.70

BAMBOO RODS, FULL LENGTHS

Length.....	12	14	16	18	20 feet.
Per 100.....	\$6.00	7.00	8.00	10.00	12.00

12, 14 and 16 feet in bundles of 100; 18 and 20 feet, 50.

Handwritten notes: 12" 34" 7.00
 16" 34" 8.00
 20" 7.00

LANDING NETS AND RINGS

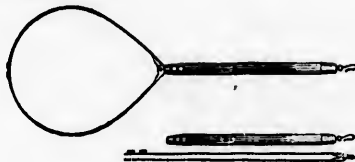

No. 3 —"Kosmic or Harrimac" Folding Ring, Jointed Bamboo Handle, 4 feet long, complete, with Net..... per doz. \$40.00
 " I.D.L. —Trout Landing Net, Bamboo Handle, 12 inches long, weight 4 ounces, complete with Net " 21.40
 " 20 —Wood Bow Landing Net, Ring, with Screw Handle, complete with Net..... " 10.00
 " 1521M—Folding Rings, four Joints, Bronzed, 15 inch diameter..... " 7.50
 " 1500 —Circular Rings, Japanned, 16 inch diameter..... " 3.00
 " 300 —Brass Sockets for Landing Net Handles..... " 3.00

NETS

Size.....	18	20	24 inch.
No. 301 —Waterproof, Square Bottom..... per doz.	\$....	7.00	8.85
" 302 —Linen, Pointed Bottom..... " "	3.40
" 303 —Cotton " Minnow Dip..... " "	6.40	7.50
" 1498M—Brown Hemp, Round Bottom, Waterproof..... " "	3.00	4.00

Handwritten note: -A 1404 net only - "910

Size...
Not Bo...
Bound.

HOOK



2540

Size Nos.
No. 2539

Size Nos.,
No. 2539
" 2538
" 2540

Inside Dia
No. 609M

CORK FLOATS

110207

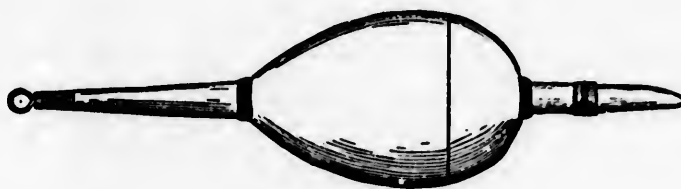

2 inch, Egg Shape.

EGG SHAPE

Size.....	1 1/4	1 1/2	2	2 1/4	2 1/2 inch
Not Bound.... per doz.	\$0.50	0.00	0.80	1.30	1.50
Bound..... "	0.70	0.80	0.95	1.25	1.55

BARREL SHAPE

Size.....	2	2 1/2	3	3 1/2 inch.
Not Bound.... per doz.	\$0.55	0.75	1.10	1.50
Bound..... "	0.65	0.85	1.20	1.70

RICE & SONS LIMITED

SWIVELS

HOOK AND SPRING SWIVELS

BRASS BOX SWIVELS



2540

2538

2539

3/0

2/0

1/0

1

2

3

4

5

6

7

8

9

10

BRASS BOX SWIVELS

Size Nos.....	10 to 1	1-0	2-0	3-0
No. 2538..... per gross	\$2.40	3.80	5.00	6.25

HOOK AND SPRING SWIVELS

Size Nos.....	8	6	4	2
No. 2539—Spring, Brass or Blue Steel..... per gross	\$4.50	4.50	4.50	4.50
" 2538—Buckle, " " "..... "	5.25	5.25	5.25	5.25
" 2540—Hook, " " "..... "	3.75	3.75	3.75	3.75

ROD FERRULES

Brass with Counter.

Inside Diameter.....	3/16	1/4	5/16	3/8	7/16	1/2	5/8	3/4	7/8	1 inch.
No. 609M..... per doz.	\$0.75	0.87	0.95	1.10	1.15	1.25	1.40	1.50	1.65	1.75

\$18.25

10.70
18.00
10.80

16.85
13.50
14.85
10.80
8.10
4.20
2.00

12.80
8.75
9.45
5.40
2.70

20 feet.
12.00
7.00
17.00

with
doz. \$40.00
" 21.40
" 10.00
" 7.50
" 3.60
" 3.60

24 inch.
8.85
3.40
7.50
....

Na 100 10

RINGED LEAD SINKERS



Nos.	13	12	10	9	8	7	6	5	4	3	2	1
Per gross.....	\$0.70	5.75	3.45	2.90	2.10	1.50	1.15	0.93	0.77	0.77	0.77	0.77

ADJUSTABLE LEAD SINKERS

Nos.	10	9	8	6	4	2
Per gross.....	\$5.75	4.80	4.40	2.65	1.90	1.45

SPLIT SHOT

In Wood Boxes.....per gross boxes \$4.00



FISH BASKETS

No. 1—Hand-made, Willow, holds 10 pounds	each	1.20
" 2— " " " " 15 "	"	1.40
" 3— " " " " 25 "	"	1.50
Fish Basket Straps, either Web or all Leather	"	0.30

CLEARING RINGS

No. 1—Polished Brass, Jointed, a good Heavy Ring.....per doz. \$11.00

DISGORGERS



No. 1

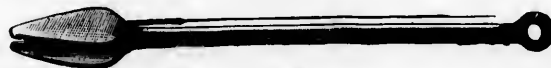

No. 2

No. 1—Brass, Nickel-Plated, with Double End.....	per doz.	8.15
" 2—Malleable Iron, Nickel-Plated, with Single End.....	"	4.05

No. 1—
" 0—
" 20—R
" 30—
" 40—
" 50—
" 60—
" 70—
" 80—

Louisville S
No. 3/O—E
" 1A—E
" 1C—F
" 2A—E
" 3A—E
" 7—A
" 9—

211070

BASEBALL MITTS



No. 99



No. 92

No. 99—Professional Catchers' Mitts, with Patent Rubber Finger Guard, Padded with Best Asbestos Padding, Patent Lacing, Best Coltskin	each	\$8.00
" 90—Same as No. 99, but a little smaller	"	6.00
" 91— " " 98, but made of Asbestos Calfskin	"	5.35
" 100— " " 98, with Reinforced Patch in Palm, without the Patent Finger Protector	"	2.70
" 92—Mouse Color Colt Skin, with Patent Lacing	"	2.00
" 93— " " " without Lacing	"	1.00
" 80—Gold Tan Leather Back, "Youths' Large Size"	"	0.70
" 101— " Canvas " "Boys"	"	0.40

BASEMAN AND INFIELDER'S MITTS AND GLOVES



No. 45



No. 32X

No. 45 —Mitts, Drab Colored Coltskin, very flexible.....	each	2.70
" 43 — " " " Palm, Red Leather Back	"	2.00
" 42 — " Craven Tanned Leather	"	1.00
" 41 — " Yellow Leather	"	0.80
" 32X—Gloves, Mouse Colored Buckskin, Padded Palm	"	4.00
" 7X— " Drab Colored Coltskin	"	2.70
" 29 — " " "	"	1.00
" 3X— " Drab Chrome Tanned Leather	"	1.00

INFLATED BODY PROTECTOR

No. 1 —League Catchers' Protector	each	15.15
" 1A—Amateur " "	"	9.50
" 1B—Boys' " "	"	8.20

TOE PLATES

No. 1—Tempered Steel, Hand Forged, High Grade	per doz. pair	7.30
" 2— " " "	"	3.65

HEEL PLATES

No. 3—Tempered Steel	per doz. pair	3.05
----------------------------	---------------	------

No. 0—Bl
" 1—Bl
" 2—Bl
" XX—Ar
" X—Ar
" C—Yd
" D—Yd
" E—Bo



No. 1—3 fe
" 2—4 fe
" 4—4 fe
" 6—4 fe
" 6 1/2—Sar
" 12—4 fe
" 13—Sar
" 14—4 fe
" 15—Sar

LACROSSE

Bristol, Wh
Cleveland,
Standard,
Eclipse, Bes
Horseman,
Ladies' Spec
LAWN TEN

BASEBALL MASKS

No. 1001



	Each	
No. 0—Black Enameled, with Patent Neck Protector, made of the Best Soft Annealed Steel Wire, Padded with Goat Hair, Faced with Dogskin, which always remains soft and pleasant to the face.....	\$4.00	
“ 1—Black Enameled, Special Association Mask, same material as No. 0, but without the Neck Protector.	3.65	
“ 2—Bright Finish, Heavy Soft Annealed Steel Wire, Well Padded and Faced with Horsehide, a good reliable Mask	3.05	
“ XX—Amateur Men's Mask, made of Heavy Wire, Well Padded and Finished in the best manner.....	2.20	
“ X—Amateur Boys' Mask, made in same style and quality as No. XX, only smaller in size	1.55	
“ C—Youths' Mask, Heavy Wire and Well Padded, without Head or Chin Piece	0.95	
“ D—Youths' Mask, Light Wire and Padded, without Head or Chin Piece.....	0.65	
“ E—Boys' Mask, Light Wire, without Head or Chin Piece	0.35	

LACROSSE STICKS



Nos. 4 to 7

No. 1—3 feet 10 inches in length, Best White Hickory and Finest Line Strings	per doz.	\$8.45
“ 2—4 feet, same as No. 1.....	“	9.85
“ 4—4 feet 6 inches, Practice Stick, 16ths to the dozen, made of the Best White Hickory and Fine Line Strings	“	16.90
“ 6—4 feet 4 inches, Home Stick, same in every way as No. 4	“	15.50
“ 8—Same as No. 6, only Left Hand.....	“	15.50
“ 12—4 feet 6 inches, Professional Stick, Best Selected Hickory, and strung with Best Syor Strings	“	21.10
“ 13—Same as No. 12, only Left Hand.....	“	21.10
“ 14—4 feet 6 inches, C.L.C. Stick, Choiceest White Hickory, strung with Syor Strings, with Clock Core in Wearing Parts	“	28.15
“ 15—Same as No. 14, but Left Hand.....	“	28.15
LACROSSE BALLS, made of Best Soft Pure Rubber.....	“	4.30

LAWN TENNIS RACKETS



Assorted Weights, 10½ to 15 ounces.

Bristol, White Ash Frames, strung with Oriental Gut	each	1.85
Cleveland, “ “ “ “	“	2.45
Standard, “ “ “ “ Full Size, High Grade.....	“	3.25
Eclipse, Best “ “ “ “	“	4.00
Horseman, “ “ “ “ Tournament Strung, Scored Handle	“	5.00
Ladies' Special, Best White Ash Frames, strung with Oriental Gut, Scored Handle	“	5.00
LAWN TENNIS BALLS.—No. 1, Collegc Championship, Regulation Size	per doz.	4.25

№ 41370

LAWN TENNIS MARKERS



The Gem, Wooden Box Frame, Iron Ratchet Wheel, Jointed Handles each \$3.25
 This Marker requires no mixing of material with water; marble dust, air-slacked lime, plaster of Paris, or ground plaster will answer the purpose. By sprinkling immediately after making the lines renders it more permanent.

LAWN TENNIS POLES

No. 1—Hardwood Pole, Varnished, Plain to Drive per pair \$1.15
 " 2— " " " with Iron Spike 1.50
 " 3— " " " Extra Heavy, Varnished, Plain to Drive, with Iron Spike and Screw Eyes.. " 2.25

LAWN TENNIS NETS

No. 1—White Cotton, 12 Thread, 42 x 3 1/2 feet, Double Court each 2.90
 " 2— " " 12 " 42 x 3 1/2 " Bound, Double Court " 4.00

GOLF STICKS

SIMPSON'S



WOOD CLUBS

Bulger Drivers	each	\$2.40	Mid Spoons	each	2.20
Bulger Driver Brassies	"	3.00	Brassie Niblics	"	2.75
Drivers	"	2.20	Erassie Spoons	"	2.75

IRON CLUBS

Cleeks	each	\$2.75	Mashies	each	2.75
Putting Cleeks	"	2.75	Gun Metal Putters	"	3.00
Irons	"	2.75			

EXTRA HEADS AND SHAFTS

Heads for Bulger Drivers	each	\$1.45	Heads for Cleeks	each	1.75
" " Bulger Brassies	"	2.00	Shafts for any style of Head	"	1.00

We also keep in stock a nice assortment of Clubs made specially for Ladies' use, at same prices as above.

GOLF BALLS

"The Edinburgh," Regulation size. This Ball is used by all the leading Clubs per doz. 5.25

TAYLOR'S GENUINE SCOTCH BOWLS

First Quality, with Ivory Buttons	per pair	7.15
Second " "	"	5.70

No. A1
 " 1
 " 2A
 " 4
 " 3
 " 5

Nos.
 Each. . .

No. 1A—

" 3—
 " 5—
 " 9—
 " 10—
 " 05—



No. 3 — F
 " 3R—

No. 15—S
 " 17—A
 " 19—B
 " 21—C

№ 04 090

CRICKET BATS

N 1 2 70



No. A1—Patent Double-spiced, Spring-Handle Bat, Thoroughly Seasoned, Hand Hammered, Edges and Face hardened in such a manner that the wood is still in possession of its natural elasticity, Accurate in Balance, Specially Selected and Stamped "Arthur Shrewsbury".....	each	\$7.80
" 1—"Specially Selected" Match Bat, are made with very best Rattan Canes, the Joints are fitted in an Improved Manner, which gives them enormous strength and a splendid spring, while "jarring" is entirely obviated, and the hardest hit can be made without feeling the slightest sting.....	each	5.95
" 2A—All Cane Handle Club Bat, Selected, Special Line for Club use.....	"	3.75
" 4 —Men's all Cane Handle Bats, not Stamped	"	2.50
" 3 —Youth's " " " " Selected	"	2.20
" 5 — " " " " Selected	"	2.00

YOUTHS' POLISHED BATS

Nos.....	01	04	05	06	07
Each.....	\$0.50	0.85	1.00	1.15	1.30

RICE LEWIS & SON
LIMITED
CRICKET BALLS

No. 1A—"Specially Selected" Treble-Sewn Match Balls, Warranted, Hand-Made, Regulation Size and Weight, as used in all matches, played by the Earl of Sheffield's Team in Australia, also the great matches in England, including England and Australia. Highly recommended by Dr. W. C. Grace and the leading English bowlers.....	each	2.50
" 3—Treble Sewn, Hand Made, Strongly Recommended, a really first-rate practice ball.....	"	2.10
" 5—Double Seam, Hand Made, Regulation Size and Weight, a good sound ball, will stand a lot of wear	"	1.90
" 9—Youths' Two-Seamed, Hand Made, Small Red, Halves	"	0.95
" 10—Youths' Three-Seamed, Hand Made, Large Red, Halves	"	1.40
" 05—Composition, Regulation Size, good practice ball.....	"	0.40

WICKETS

No. 10—Best Selected Ash, 1½ inch Improved Brass Ferrules.....	per set	2.50
" 11— " " " " 1½ " Brass Ferrules.....	"	2.00
" 15— " " " " Polished, Youths'.....	"	1.00

LEG GUARDS

No. 3—Buff Chamois Leather, with Continuous Straps and Buckles.....	per pair	2.70
" 7—White Buckskin, with 3 Straps, Improved Buckles.....	"	3.10
" 16—Best White Buckskin, Skeleton Pattern, with Continuous Straps and Buckles, per pair.....	"	4.40

WICKET KEEPING GAUNTLETS

No. 3—Tan Kid, Ventilated Back and Front.....	per pair	3.00
" 4—White Kid, " " " "	"	3.00
" 6—White Buckskin, Ventilated Back and Front	"	3.00
" 13—White Buckskin, " " " " Youths'.....	"	2.45
" 14—Best Chamois Leather, Buff, Ventilated Back and Front, Youths'.....	"	1.80

BATTING GLOVES

No. 3 —Excelsior, Grey Rubber Backs, no Buttons	per pair	2.30
" 3R— " " Red " "	"	2.55

BOOT SPIKES

No. 15—Sparrow Bill, Plain Steel Spike.....	per gross	0.60
" 17—Alpine, Pyramid Shape, to Drive.....	"	3.00
" 19—Blackey's, Steel Peg, to Drive	"	3.00
" 21—Ice Nail, Square, 4 points, to Screw.....	"	3.00

each \$3.25
of Paris, or
orders it more

pair \$1.15
1.50
2.25

each 2.00
4.00

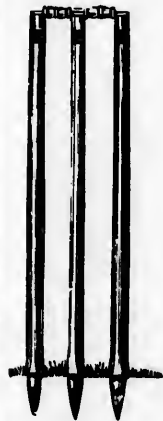

each 2.29
2.75
2.75

each 2.75
3.00

each 1.75
1.00
as above,

per doz. 5.25

per pair 7.10
5.70

11015590

FOOTBALLS



ASSOCIATION



RUGBY

ASSOCIATION OR RUGBY

Size Nos.....		3	4	5
No. A—Best Grained Leather, Covers only.....	each	\$1.20	1.30	1.45
" B—Grained Leather, ".....	"	1.00	1.15	1.30
" C—Undressed Leather, ".....	"	0.80	1.00	1.15
Football Bladders.....	per doz.	5.10	6.55	8.25

RUBBER FOOTBALLS

Size Nos.....		2	3	4	5
Per dozen.....		\$7.50	8.50	9.70	10.90

These Balls require no bladder, and are inflated by means of a valve. This is by far the best Ball for youths' general use.

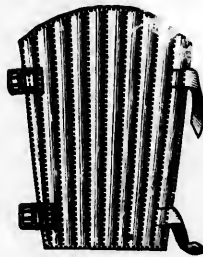

No. 1

FOOTBALL SHIN-GUARDS

No. 1—Leather, length 10 inches.....	per doz. pair	\$ 7.20
" 2— " " 10 " with Ankle-Guards.....	" "	10.90

QUOITS



W & S WYNN & CO
4 lbs

London Pattern, Superior Wrought Steel, Hardened and Polished.

Weight per pair.....	4	5	6	7	8	10	12	14	16 lbs.
Per pair.....	\$1.90	2.35	2.75	3.20	3.60	4.90	7.00	8.50	10.20

MALLEABLE IRON QUOITS

Weights, 3, 4, 5, 6, 7, 8, 0, 10 lbs. each.....	per lb.	\$0.12
---	---------	--------

DUMB-BELLS



IRON

Weights each, 1½, 2, 3, 3½, 4, 4½, 5, 6, 7, 8, 9, 10, 12, 14 lbs.	
Per lb.....	\$0.08

WOOD

Made of Selected Maple, Oiled, Lathe Polished.

Weights... each	½	1	1½	2	2½	3 lbs.
Per pair.....	\$0.20	0.28	0.30	0.40	0.50	0.60 0.70

PITCHING SHOT



Weights, 10 to 50 lbs.	per lb.	\$0.08
-----------------------------	---------	--------

INDIAN CLUBS

Made of Selected Maple, Oiled, Lathe Polished, Well Shaped and Balanced.

Weights... each	½	1	1½	2	3	4	5	6 lbs.
Per pair.....	\$0.25	0.35	0.40	0.50	0.60	0.90	1.00	1.15

No. 1-
" 2-
" 3-

" 17-
" 117-

Single St
Extra St

No. 10-F
" 11-
" 13-
" 38-G

No. 14-F
" 15-

No. 217-

FENCING FOILS

No. 3.70



No. 1—Iron Mounted, Corded Handles, 34 inch Blades.....	per pair	\$1.75
" 2—Brass " Black Leather Corded Handles, 34 inch Blades.....	"	2.50
" 3— " " White " " " with Helmet Heads and White Leather Overguard, 34 inch Blades.....	"	4.00
" 17—Blades only 34 inch, Polished.....	"	1.20
" 117— " " " Klingenthal Blades, Polished, Fine Quality.....	"	1.70



Single Sticks, Cane Baskets, Willow or Ash Sticks.....	per pair	0.75
Extra Sticks.....	per doz.	1.50

FENCING MASKS



No. 10



No. 11

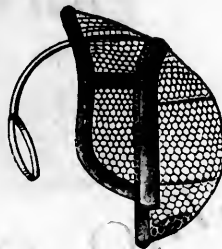

No. 13



No. 38

No. 10—French Pattern, Standard Quality, Face Protecting.....	per pair	2.70
" 11— " " " " Face and Ear Protecting.....	"	3.50
" 13— " " " " Face, Ear and Head Protecting.....	"	4.50
" 38—German " Helmet Covering Face, Ears and Back of Head, for Broadsword exercise...	"	9.50

FENCING GLOVES

No. 14—Fencing Gloves, without Gauntlets.....	per pair	2.00
" 15— " " with "	"	2.50

BODY PROTECTORS

No. 217—Plastrons or Fencing Body Protectors, Canvas.....	each	6.00
---	------	------

1101-270

BOXING GLOVES



No. 020



No. 032



No. 024

No.	Description	Per set.	No.	Description	Per set.
No. 02	Boys' Boxing Gloves, made of Gold Tan Kid, Elastic Wrist and filled with Curled Hair. Style as 024	\$1.75	No. 013X	Men's Boxing Gloves, made of Benton Tan Kid, Laced, and filled with superior quality Curled Hair. Style as 020	\$6.00
" 07	Boys' Boxing Gloves, made of White Kid, Elastic Wrist, Filled with Curled Hair. Style as 024	1.00	" 020	Men's Boxing Gloves, made of fine imported Colored Kid, fac-simile in style of the gloves used at the Corbett-Mitchell contest at Jacksonville. Laced, and filled with the finest quality of Curled Hair	8.00
" 02X	Boys' Boxing Gloves, made of Gold Tan Kid, Elastic Wrist, and filled with Curled Hair. Style as 020	2.40	" 024	Men's Boxing Gloves, made of Benton Tan Kid, Gold Tan Palm, California Thumb, Padded Wrist, Laced, and filled with a superior quality Curled Hair	5.35
" 03	Boys' Boxing Gloves, made of Wine Colored Kid, Elastic Wrist, and filled with good quality Curled Hair. Style as 020	2.40	" 026	Men's Boxing Gloves, made of White Kid, Elastic Wrist, and filled with good quality Curled Hair. Style as 020	3.35
" 03X	Boys' Boxing Gloves, made of Wine Colored Kid, Elastic Wrist, filled with good quality Curled Hair. Style as 020	2.70	" 027	Men's Boxing Gloves, made of White Kid, Elastic Wrist, and filled with good quality Curled Hair. Style as 024	2.40
" 04	Men's Boxing Gloves, made of Wine Colored Kid, Elastic Wrist, filled with good quality Curled Hair. Style as 020	4.00	" 030	Men's Boxing Gloves, made of Gold Tan Kid, Elastic Wrist, and filled with Curled Hair. Style as 024	2.40
" 07X	Boys' Boxing Gloves, made of White Kid, Elastic Wrist, and filled with Curled Hair. Style as 020	2.40	" 030X	Men's Boxing Gloves, made of Gold Tan Kid, Elastic Wrist, and filled with Curled Hair. Style as 020	3.00
" 013	Men's Boxing Gloves, made of Benton Tan Kid, Laced, and filled with superior quality Curled Hair. Style as 024	5.35			

The better quality of Gloves are stocked in 6 and 8 ounces. 8 ounces will be sent unless weight is specified.

STRIKING BAG GLOVES

No. 034	Oil Tan, Padding in Back	per pair	\$0.80
" 032	Wine Color, Padding in Back, with Hand Bar in Palm	"	1.35

STRIKING BAGS

Complete with Bladders, Double Loop and Rubber Cord.

No. 81XB	Oiled Tan Yellow Bag, 27 inch	each	\$2.30
" 81X	" " " 30 "	"	2.50
" 81	Lined Oiled Tan Yellow Bag, 30 inch	"	2.90
" 84	" " " 30 " Double Seamed	"	3.10
" 65	Lined Craven Tan Dark Bag, 30 " Welt	"	3.75
" 82X	" " " 30 " Double "	"	4.45
" 86	Lined Green Tan " 32 " Welt	"	5.15
" C	Best Grained Leather Bag, 30 " Hand Sewed	"	3.40
" C	" " " 32 " " "	"	4.40
Single Loop, for using with Platform.			
No. 81	Lined Oiled Tan Yellow Bag, 30 inch	each	2.25
" 85	" Craven Tan Dark " 30 " with Seam	"	3.10
" 86	" Green Tan " 32 " " "	"	4.50
" 83	" " " 32 " Double Seamed	"	6.20
" C	Best Grained Leather " 30 " Hand Sewed	"	2.75
" C	" " " 32 " " "	"	3.75



DOUBLE LOOP



SINGLE LOOP

Nos.
Extra He

36 inch, fo

No. 1 - Sir

" 2 - Do

" 3 - Do

" 4 - Do

" 4 1/2 - Do



No. A1 - Qu

" B2 -

" B4 -

" B5 - Ful

" E4 -

" E5 -

" G5 -

" K4 -

" NE4 -

" NE5 -

" P5 -

STRIKING BAG BLADDERS

Nos.....	5	6	8
Extra Heavy Striking Bag Bladders.....	each \$0.70	0.80	1.30

RUBBER CORDS

36 inch, for using with Double Loop Bag, between Floor and Bag.....each \$0.35

HOME EXERCISERS

- No. 1 —Single Elastic, Fitted with Patent Compound Rope, and Patent Fibre Bushed Metal Wheels, rendering when in use absolutely noiseless, Interchangeable, Enamel Finish.....each \$2.20
- “ 2 —Double Elastic, otherwise same as No. 1..... “ 3.75
- “ 3 —Double Elastic, with Plated Mountings..... “ 4.50
- “ 4 —Double Elastic, Full Nickel, Polished, with Silk Elastic Cord, Wood Handles.....each 6.00
- “ 4½ —Double Elastic, Full Nickel, Polished, with Silk Elastic Cord, Cork Handles.....each 6.75

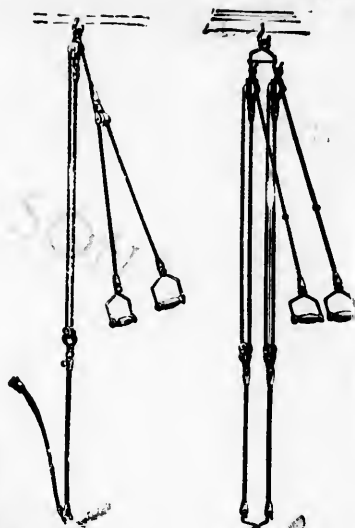

No. 1

Nos. 2 to 4½

HAMMOCKS

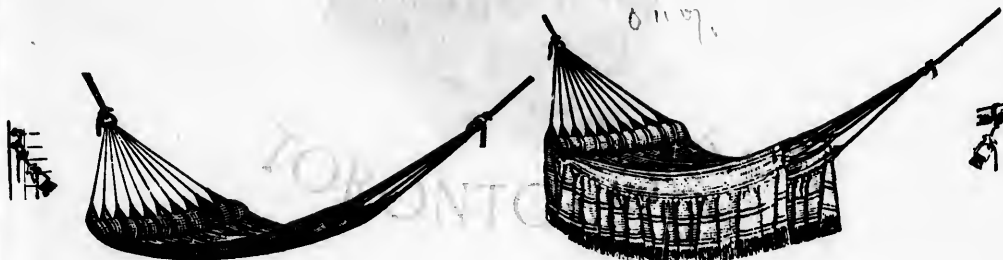

WITH PILLOW

WITH VALANCE

No.	A1	Quarter Color, 34 x 70 inch, Open Weave.....	per doz.	\$11.70
“	B2	“ “ 36 x 76 “ “ one Patent Wood Spreader.....	“	14.50
“	B4	“ “ 36 x 70 “ “ Spreader and Pillow.....	“	18.00
“	B5	Full “ 36 x 70 “ “ “ and Valance.....	“	30.00
“	E4	“ “ 36 x 76 “ Combination Weave, Spreader and Pillow.....	“	25.00
“	E5	“ “ 36 x 70 “ “ “ Pillow and Valance.....	“	37.00
“	G5	“ “ 40 x 78 “ Twilled “ “ “.....	“	51.00
“	K4	“ “ 41 x 78 “ Open “ “ and Pillow.....	“	29.50
“	NE4	“ “ 36 x 76 “ Corded “ “ Stretcher and Pillow.....	“	28.00
“	NE5	“ “ 36 x 70 “ “ “ “ Pillow and Valance.....	“	40.00
“	P5	“ “ 40 x 78 “ “ “ “ Pillow and Valance.....	“	50.00

DOG COLLARS



UNLINED



LINED

UNLINED

No. 260	— $\frac{1}{2}$ inch wide,	lengths assorted 9 to 13 inches, Brass, Nickel-Plated	per doz. \$2.00
" 261	" " "	" " " 13 to 17 " " "	2.55

WITH HARD LEATHER LININGS

No. 250S	— $\frac{1}{2}$ inch wide,	lengths assorted 9 to 13 inches, Brass, Polished	per doz. 2.70
" 251S	" " "	" " " 13 to 17 " " "	3.35
" 260S	" " "	" " " 9 to 13 " " Nickel-Plated	3.45
" 261S	" " "	" " " 13 to 17 " " "	3.75
" 262S	" " "	" " " 17 to 21 " " "	5.20

WITH CHAMOIS LINED LININGS

No. 250C	— $\frac{1}{2}$ inch wide,	lengths assorted 9 to 13 inches, Brass, Polished	per doz. 4.50
" 251C	" " "	" " " 13 to 17 " " "	5.15
" 260C	" " "	" " " 9 to 13 " " Nickel-Plated	4.65
" 261C	" " "	" " " 13 to 17 " " "	5.40



No. 427



Nos. 915 and 925

No. 427	Lengths assorted	13 to 17 inches, Black Leather, Nickered Trimmings and Studs	Per doz. 18.00
" 406	" " "	" " " 13 to 17 inches, Russet Leather, Nickered Trimmings and Studs	8.65
" 407	" " "	" " " 16 to 20 " " " " " " " " " "	10.00
" 415	" " "	" " " 18 to 22 " " Black " " " " " " " "	13.00
" 465	" " "	" " " 25 to 20 " " Russet " " " " " " " "	16.00
" 605	" " "	" " " 9 to 13 " " " " " " " " " " " "	5.75
" 915	" " "	" " " 9 to 13 " " " " " " " " " " " "	6.50
" 925	" " "	" " " 11 to 15 " " " " " " " " " " " "	7.25
" 935	" " "	" " " 14 to 20 " " " " " " " " " " " "	10.00



No. 945



No. 954

No. 945	— $\frac{7}{8}$ inch wide,	lengths assorted 13 to 17 inches, Russet Leather, Chamois Lined, Nickered Trimmings	8.00
" 954	" " "	" " " 15 to 19 " " " " " " " " " " " "	13.00

No. 41
" 42
" 71
" 74

No. 10
" 10
" 10

No. 268N
" 62N
" 352N
" 353N
" 273N
" 273N
" 273N
" 295N
" 295N
" 295N

No. 5M-S

No. 1B-S
" 2B-

No. 78N-

DOG COLLARS

No 20075

ROUND LEATHER COLLARS



No. 45	—Collie, ¾ inch diam., lengths assorted 11 to 20 inches, Brass Trimmings, Plain Buckle.....	per doz.	\$ 7.20
" 45L	— " " " " " " " " " " " " " " Lock " " " " " " " " " " " "	" " " "	8.00
" 71	— " " " " " " " " " " " " " " Studded " " " " " " " " " " " "	" " " "	10.00
" 74	—St. Bernard, ¾ inch diam., lengths assorted 18 to 30 inches, Brass Trimmings, Lock Buckle .	" " " "	20.00

FLAT LEATHER COLLARS

No. 100	—Terrier, ¾ inch wide, lengths assorted 12 to 15 inches, Brass Buckle and Ring.....	per doz.	3.00
" 102	— "	" " " "	4.00
" 104	— " 1 "	" " " "	5.00

METAL BAND COLLARS



No. 268N



No. 352N

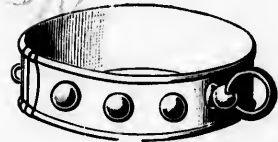

No. 273N

No. 268N	—Lined, ¾ inch wide, lengths assorted 9 to 15 inches, Brass, Nickel-Plated .	per doz.	8.50
" 62N	— " ¾ " " " " " " " 12 " 15 " " " " " " " " " " " " " " " "	" " " "	8.00
" 352N	— " ½ " " " " " " " " 9 " 12 " " " " " " " " " " " " " " " "	" " " "	7.00
" 353N	— " 1 " " " " " " " " 12 " 15 " " " " " " " " " " " " " " " "	" " " "	11.20
" 273N	— " 1 ¾ " " " " " " to 24 inches, Brass, Nickel-Plated.....	" " " "	24.00
" 273N	— " 1 ¾ " " " " " " " 26 " " " " " " " " " " " " " " " " " "	" " " "	28.80
" 273N	— " 1 ¾ " " " " " " " 28 " " " " " " " " " " " " " " " " " "	" " " "	36.00
" 295N	— " 1 ¾ " " " " " " " 24 " " Plain " " " " " " " " " " " " " "	" " " "	22.00
" 295N	— " 1 ¾ " " " " " " " 26 " " " " " " " " " " " " " " " " " "	" " " "	26.50
" 295N	— " 1 ¾ " " " " " " " 28 " " " " " " " " " " " " " " " " " "	" " " "	32.50

CHAIN COLLARS



SINGLE CURB LINK

No. 5M	—Steel Chain, lengths assorted 13 to 15 inches, Lock attached	per doz.	4 50
--------	---	----------	------



DOUBLE CURB LINK

No. 1B	—Steel Chain, lengths assorted 13 to 15 inches, Lock attached.....	per doz.	7.50
" 2B	— " " " " " " " " 18 " 24 " " " " " " " " " " " " " " " "	" " " "	12.00



FLAT LINK

No. 78N	—¾ inch wide, lengths assorted 9 to 15 inches, Lock attached, Nickel-Plated	per doz.	18.00
---------	---	----------	-------

No. 10 12 970

HANDCUFFS

TOWERS' ADJUSTABLE DOUBLE LOCK



Nos. 10 and 11

No. 10—Forged Steel Shackles, Polished.....per pair \$6.00
 " 11— " " Nickel-Plated..... " 7.15

They are adjustable to any size and can be closed instantly to an exact and secure fit. Two Tumbler Locks, one Self-Locking, the second locked with the Key. The same Key unlocking both when double locked by turning twice around in the same direction.

BEAN'S PATENT HANDCUFFS



Nos. 1 and 2

No. 1—Polished, Adjustable, Weight 14 ounces, for Patrolmen.....per pair \$6.00
 " 1—Nickel-Plated, " " 14 " " " 7.15
 " 2—Polished, " " 17 " Prisons..... " 6.00
 " 2—Nickel-Plated, " " 17 " " " 7.15

These Cuffs have one Link and two Swivels. The Lock has three Bolts, each independent of the other, supplied with Stop Catch which is operated with the thumb by a button on the outside of the case and prevents them being locked by the prisoner in a tussle with the officer who is attempting to arrest him.

TOWERS' PERFECT TWISTERS



No. 21

No. 21—Welded Steel Chain, Nickel-Plated, Weight 3 ounces.....each \$1.50
 " 23—Phillips' Patent Police Nippers, Forged Steel, Nickel-Plated, Weight 4 1/2 ounces..... " 1.50



No. 4



No. 5



No. 1

- No. 4369—
- " 5117—
- " 1143—
- " 5169—

Outside diam
 No. 4368—S

Size
 No. 904—Jap

KEY RINGS AND CHAINS



No. 4889



No. 5117



No. 1143



No. A54



No. 100 and 101

RICH LEWIS & CO
1877

KEY CHAIN RINGS

Length, 5½ inches.

	Per doz.
No. 630—Polished Steel, with Screw Fastening	\$2.40
" 5371—Nickel Steel Chain, with Snap and Ring	0.00
" 5373—Gilt Steel Chain, with Snap and Ring	1.00

KEY CHAINS

Length, 20 inches.

	Per doz.
No. 100—Steel, Nickel-Plated	\$1.10
" 101—Aluminum	2.30
" 11356—Polished Steel Chain, Straight Link, Heavy, with 1½ inch Split Ring and Leather Button Loop	1.00
" 5752—Polished Steel Chain, Twisted Link, with Fancy Key Ring and Leather Button Loop	1.50
" 6489—Polished Steel Chain, Light Double Link, with 1½ inch Split Ring, and Steel Button Loop	0.50
" A54—Nickel-Plated Steel Chain, Twisted Link, with Snap and Leather Button Loop	4.90

KEY RINGS

	Per gross,
No. 4889—Gilt, round Steel, Split, Assorted on Dozen Cards	\$5.00
" 5117—Polished Steel, Split, with Bone Labels, Assorted on Dozen Cards	3.30
" 1143—Nickel-Plated Flat Steel, with Patent Lock, Assorted on Dozen Cards	10.00
" 5169—Polished Flat Steel, Split, Decorated on Dozen Cards	4.00

SPLIT RINGS

Outside diameter	¾	⅞	1 inch.
No. 4388—Steel Polished, per gross	\$0.50	0.60	0.80

MAGNETS



Size	2	3	4	5	6 in.
No. 904—Jap'd Red, per doz.	\$0.70	1.00	1.80	2.80	4.00

SPECTACLES



No. 122C—Light Steel Frame, Blue	per doz.	2.50
" 1264—Light Steel Frame, Blue, with Two Screws and Round Sides	per doz.	3.50

HARVESTING TOOLS



3 TINE HAY FORK

No. 97-2	Tine, Cast Steel, Boys' Fork, Balloon Tine	per doz.	\$6.00
" 98-2	" " Hay Fork, Capped Ferrule, Balloon Tine	"	7.00
" 99-2	" " " Bent Han	"	7.50
" 101-2	" " Strapped Ferrule, Capped, Balloon Tin	"	8.50
" 104-3	" " Capped Ferrule, Balloon Tine	"	8.50
" 105-3	" " " Bent Handle	"	9.00
" 107-3	" " Strapped Ferrule, Capped, Balloon Tine	"	9.75
" 108-3	" " " Bent Handle	"	10.25
" 109-3	" " Straw Fork, Capped Ferrule, 14 inch Balloon Tine, Straight Handle	"	10.25
" 113-4	" " Plain Capped Ferrule, 16 inch Balloon Tine, Bent Handle	"	15.75

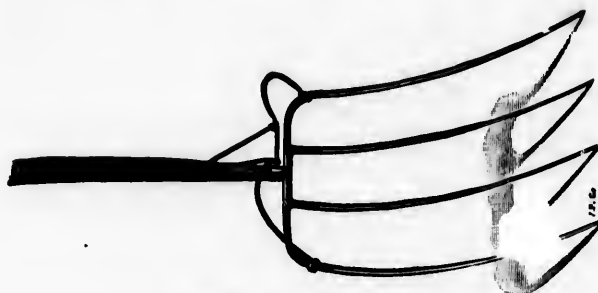

4 TINE FARLEY FORK
With Moveable Back.

No. 215-4	Tine, Cast Steel, Barley Fork, Plain Capped Ferrule, 20 in. Balloon Tine, Bent Handle	Per doz.	17.75
" 115-4	Tine, Cast Steel, Barley Fork, Plain Capped Ferrule, 20 in. Balloon Tine, Bent Handle, with Moveable Back		19.75

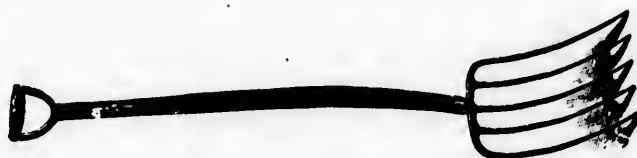

4 TINE D. H. MANURE FORK

No. 120-4	Tine, Cast Steel, Manure Fork, L. H., Capped Ferrule, Balloon Tine, Solid Steel Shank	Per doz.	11.75
" 121-4	" " " Strapped " Capped, Balloon Tine, Solid Steel Shank		13.25
" 122-4	" " " D. H., Capped " Balloon Tine, Solid Steel Shank		13.00
" 123-4	" " " Strapped " Capped, Balloon Tine, Solid Steel Shank		14.25
" 128-5	" " " L. H., Capped " Balloon Tine, Solid Steel Shank		18.00
" 129-5	" " " Strapped " Capped, Balloon Tine, Solid Steel Shank		19.25
" 130-5	" " " D. H., Capped " Balloon Tine, Solid Steel Shank		19.00
" 131-5	" " " Strapped " Capped, Balloon Tine, Solid Steel Shank		20.50
" 132-6	" " " L. H., Capped " Balloon Tine, Solid Steel Shank		21.00
" 133-6	" " " Strapped " Capped, Balloon Tine, Solid Steel Shank		22.50
" 134-6	" " " D. H., Capped " Balloon Tine, Solid Steel Shank		22.00
" 135-6	" " " Strapped " Capped, Balloon Tine, Solid Steel Shank		23.25

No. 124
" 125
" 126
" 127

No. 136
" 137
" 138
" 139

No. 140
" 141

No. 142
" 144

No. 149
" 150

FORKS



4 TINE D. H. MANURE FORK

Acme Double Shank.

No. 124—4 Tine, Cast Steel, Manure Fork, L. H., Capped Ferrule, Balloon Tine, Solid Steel Shank.....	per doz.	\$13.00
" 125—4 " " " " " " Strapped Ferrule, Capped, Balloon Tine, Solid Steel Shank.....	per doz.	14.50
" 126—4 Tine, Cast Steel, Manure Fork, D. H., Capped Ferrule, Balloon Tine, Solid Steel Shank.....	per doz.	14.00
" 127—4 " " " " " " Strapped Ferrule, Capped, Balloon Tine, Solid Steel Shank.....	per doz.	15.75

r doz. \$6.00
 .. 7.00
 .. 7.50
 .. 8.50
 .. 8.50
 .. 9.00
 .. 9.75
 .. 10.25
 .. 10.25
 .. 15.75

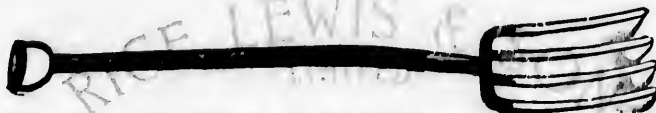

4 TINE D. H. SPADING FORK

No. 136—4 Tine, Cast Steel Spading Fork, L. H., Capped Ferrule.....	per doz.	15.75
" 137—4 " " " " " " Strapped Ferrule, Capped.....	"	17.50
" 138—4 " " " " " " D. H., Capped.....	"	17.00
" 139—4 " " " " " " Strapped " Capped.....	"	18.00

Per doz.
 .. 17.75
 with
 .. 10.75



4 TINE L. H. POTATO FORK

No. 140—4 Tine, Cast Steel Potato Fork, L. H., Capped Ferrule.....	per doz.	12.75
" 141—4 " " " " " " D. H., ".....	"	14.00



4 TINE POTATO HOOK

No. 142—4 Tine, Cast Steel Potato Hook, Round Back.....	per doz.	8.50
" 144—4 " " " " " " Diamond Back.....	"	10.00

Per doz.
 .. 11.75
 .. 13.25
 bank .. 13.00
 .. 14.25
 .. 18.00
 bank .. 19.25
 .. 19.00
 bank .. 20.50
 .. 21.00
 bank .. 22.50
 .. 22.00
 bank .. 23.25



4 TINE MANURE DRAG

No. 149—4 Tine, Cast Steel Manure Drag.....	per doz.	10.50
" 150—5 " " " " " ".....	"	12.50

VEGETABLE SCOOPS

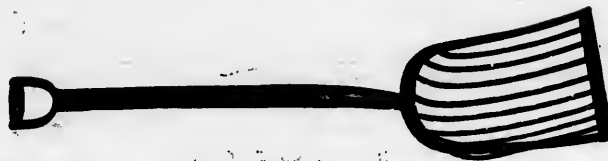

No. 152—10 Tines, Cast Steel Vegetable Scoop, D. H. 16 x 12 $\frac{1}{2}$ inches per doz. \$22.00
 Little Giant, 11 Tines, Malleable Iron Vegetable Scoop, 14 x 12 $\frac{1}{2}$ " " 28.00

HOES



SOLID SOCKET FIELD HOE

No. 153—Cast Steel, Riveted Shank, Field Hoe, 8 x 5 inch per doz. 5.50
 " 154— " Solid Neck, " 8 x 5 " " 7.50
 " 155— " Socket, " 8 x 5 " " 9.00
 " 156— " Neck, Garden Hoe, 6 x 4 $\frac{1}{2}$ " " 7.00
 " 158— " Ladies' 4 $\frac{1}{2}$ x 3 $\frac{1}{2}$ " " 6.50



SOLID NECK TURNIP HOE

No. 160—Cast Steel, Solid Neck, Turnip Hoe, Assorted, 8 to 10 inch Blade per doz. 8.25



SOLID NECK CARROT HOE

SOLID NECK WEEDING HOE

No. 162—Cast Steel, Solid Neck, Carrot Hoe per doz. 7.00
 " 165— " " 4-Tooth Weeding Hoe " 8.25

SOLID NECK TURF EDGERS



No. 161—Cast Steel, Solid Neck, Turf Edger, 9 x 3 inch, L Handle per doz. 13.50

SOLID NECK WEED CUTTERS OR THISTLE SPUDS

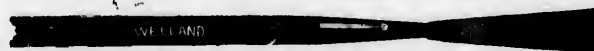

No. 166—Cast Steel, Solid Neck, Weed Cutter or Thistle Spud per doz. 5.00

No. 168—
 " 167—

No. 60—C

No. 169—C

MORTAR HOES

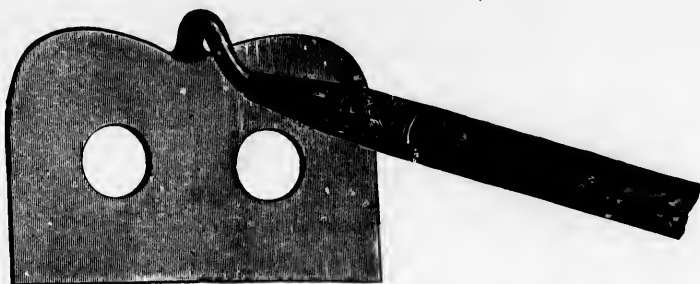

- No. 168—Improved Cast Steel Mortar Hoe, Hammer Finished, Size $9\frac{1}{2}$ x $6\frac{1}{2}$ inches per doz. \$13.50
 " 167—Cast Steel Mortar Hoe, Hammer Finished, Size $9\frac{1}{2}$ x $6\frac{1}{2}$ inches, without Holes " 12.50

ICE CHOPPERS



- No. 60—Cast Steel Ice Chopper or Side Walk Cleaner, L Handle per doz. 12.50

GARDEN SETS

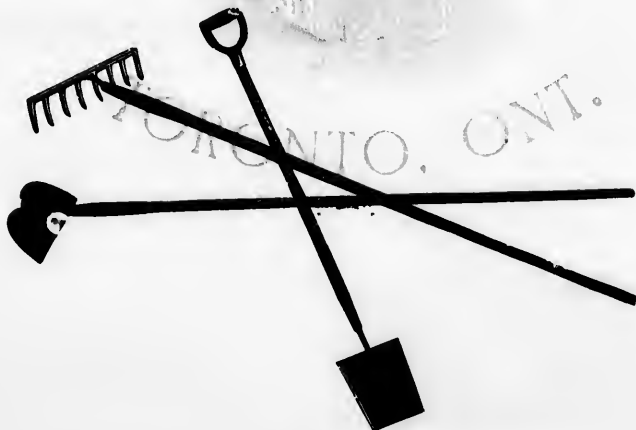

No. 169

- No. 169—Cast Steel Garden Tools (Spade, Hoe, Rake)..... per set 2.50

GARDEN RAKES



MALLEABLE IRON GARDEN RAKES

No. 180—Malleable Iron Garden Rake, Patent Braced Head, 12 Teeth	per doz.	\$6.00
" 181— " " " " " 14 "	"	6.50
" 182— " " " " " 16 "	"	7.00



STEEL GARDEN RAKES

No. 171—Cast Steel Garden Rake, Patent Brace Head, Solid Steel Shank, 10 Teeth, Concave	per doz.	8.75
" 172— " " " " " 12 "	"	9.75
" 173— " " " " " 14 "	"	10.75
" 174— " " " " " 16 "	"	12.00



No. 300

No. 300—Dunn's Lawn Rake, Steel Blade	per doz.	12.00
---	----------	-------



Nos. 20 and 24

No. 20—Gibbs' Lawn Rake, All Steel, 17 1/2 inch Head, 20 Teeth, Reversible, Heavily Tinned	per doz.	8.00
" 24— " " " " " 21 " " 24 "	"	8.70
Ohio Girl—18 inch Head, 20 Coppered Steel Wire Teeth, Heavily Tinned	"	6.00

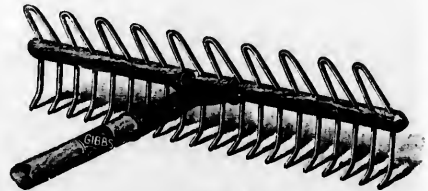

"OHIO GIRL"

No. 1
" 2
" 3
" 4

Length
Extra

Malleab
Spade L

Per doz

Half Mul
" "
Turkey V
" "
CRADLE

HAY RAKES



No. 1—Wood Bow, Straight Handle	per doz.	\$1.20
" 2— " Bent	"	1.35
" 3—Wire Bow, Straight	"	1.25
" 4— " Bent	"	1.40

HANDLES

Polished Fork Handles, Chucked and Bored.

Length.....		4	4½	5	5½	6 ft.
Extra Ash, Hay Fork Handles, Straight	per doz.	\$1.20	1.40	1.60	1.80	2.00
" " " Bent	"	1.45	1.65	1.85	2.10	2.35
" Barley " "	"			2.00	2.25
" Manure " Long, Bent	"	1.75
" " " Short without D. Top	"	1.10
" " " Complete with D. Top	"	2.00
" Hoe Handles, 4½ feet	"	0.05
" Turnip Hoe Handles, 5 feet	"	1.10
" Rake " 5½ "	"	1.25
" Long Shovel Handles, 4½ feet	"	2.00
" Spade " 4½ "	"	2.00
" D. Shovel " "	"	2.50
" D. Spade " "	"	2.50
Malleable D. Tops, only for Manure Forks	"	1.60
Spade Lifters, Malleable Iron, Wood Handle	"	3.20

FERRULES

Per dozen.....	Hoe	Rake	Hay Fork, Plain	Manure Fork, Plain	Pike Pole Ferrule, 4 x 1½ x 1 inch.
	\$0.90	0.90	0.95	1.10	1.10

GRAIN CRADLES



HALF MULAY



TURKEY WING

Half Mulay, with Iron Braces, without Scythe	per doz.	18.00
" " " Complete with Scythe	"	32.00
Turkey Wing, with Wooden Braces, without Scythe	"	16.00
" " " Complete with Scythe	"	31.00
CRADLE FINGERS	"	1.50

SNATHS



No. 00

No. 00—New Improved Swing Socket, Brass Ferrules.....per doz. \$12.50



PATENT LOOP

Nos.....		1	2	3
Patent Loop.....	per doz.	\$12.00	11.00	10.00



RING AND Z PLATE

No. 1—Ring and Z Plate.....per doz. 11.00



DRIVE RING AND SOCKET

Nos.....		2	3
Drive Ring and Socket.....	per doz.	\$10.00	9.00



DOUBLE RING BRUSH

No. 1—Double Ring Brush.....per doz. 12.00

No. 1-
 " 2-
 " 3-
 " 4-
 " 5-
 " 6-
 " 7-
 " 8-
 " 9-
 " 10-
 " 11-

No. 12-
 " 13-

No. 14-

No. 2-Gr
 " 3-
 " 4-

SCYTHES AND GRASS HOOKS

GRASS SCYTHES



No. 1—Cast Steel Grass Scythes, Narrow Heel	per doz.	\$....
" 2—Princess " " "	"	"
" 3—Tip Top " " "	"	"
" 4—Beard Clipper " " "	"	"
" 5— " " Wide "	"	"
" 6—Climax " " "	"	"
" 7—Damascus " " "	"	"
" 8—Whiting's Pride " " Narrow "	"	"
" 9— " " Wide "	"	"
" 10—Concave " " "	"	"
" 11—Lawn Scythes.....	"	"

\$12.50

CRADLE SCYTHES



No. 12—"Silver Steel" Cradle Scythes, Ground Sharp.....	per doz.
" 13—"Harvest King" " "	"	"

3
10.00

BUSH OR BRUSH SCYTHES



No. 14—Cast Steel Bush or Brush Scythes.....	per doz.
--	----------	------

11.00

3
9.00

GRASS HOOKS



No. 2—Grass or Reaping Hooks, Cast Steel.....	per doz.
" 3— " " " " "	"	"
" 4— " " " " "	"	"

12.00

PENNSYLVANIA LAWN MOWERS



LOW WHEEL

Open Cylinder, Height of Wheels 8 inches.

Cut	14	16	18 inch.
Each	\$17.00	19.00	21.00

HIGH WHEEL

Open Cylinder, Crucible Steel Knives, Height of Wheels 10½ inches.

Cut	17	19 inch.
Each	\$28.00	31.00

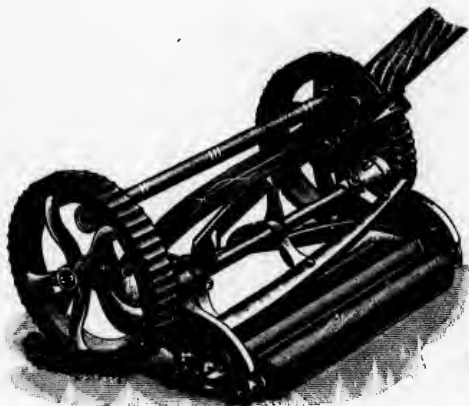

MAXWELL



WOODYATT



PHILADELPHIA

MAXWELL'S HIGH WHEEL LAWN MOWERS

Cut	12	14	16	18 inch.
Each	\$6.00	6.50	7.00	7.50

WOODYATT'S HIGH WHEEL LAWN MOWERS

Open Cylinder, Height of Wheels 10½ inches.

Cut	12	14	16	18	20 inch.
Each	\$0.75	7.00	7.50	8.25	10.00

PHILADELPHIA LOW WHEEL LAWN MOWERS

Cut	10	12	14	16 inch.
Each	\$6.00	6.00	6.00	6.00

25 inch
25 "
30 "
35 "
40 "
W
at an ac
T
walk on
grass or
F



HORSE LAWN MOWERS

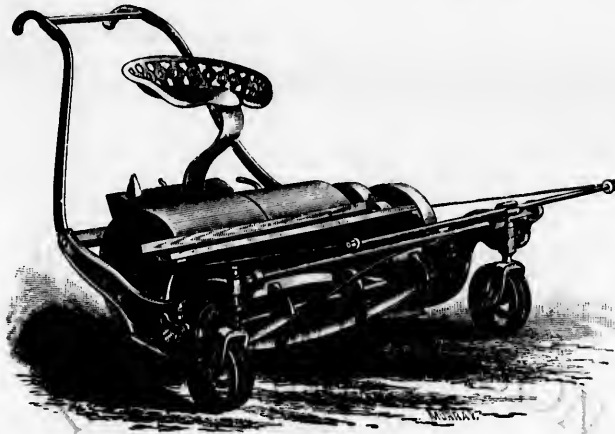

THE NEW EXCELSIOR

25 inch Cut, without Seat or Shafts, Shipping Weight 300 lbs.....	each	\$65.00
25 " with Shafts and Side-draught Attachment, Shipping Weight 300 lbs.....	"	75.00
30 " with Seat, Shafts and Side-draught Attachment, " 610 ".....	"	110.00
35 " " " " " 800 ".....	"	135.00
40 " " " " " 710 ".....	"	170.00

We do not recommend the use of a seat on the 25 inch cut Mower, but we can furnish the same when desired at an additional cost of \$5.00 to the list price of this size Mower.

The New Excelsior Horse Lawn Mower is furnished with Side-draught Attachment that permits the horse to walk only on the cut grass. The Caster Wheels are made in sections to prevent the rolling down of standing grass or marking of lawn. These machines have uniformly given entire satisfaction.

Full directions for setting up accompany each Mower.

LAWN AND GARDEN ROLLERS



No. 1



No. 2

No. 1—20 inches Wide, 20 inches Diameter, Weight 350 lbs.....	each	20.00
" 2—24 " " 20 " " 285 ".....	"	24.00

Rollers of special sizes and weights made to order.

CORN KNIVES AND HOOKS



Barclay Band Knives, Blades 18 inches Long, Riveted Handles..... per doz. \$3.00

CORN HOOKS



EUREKA

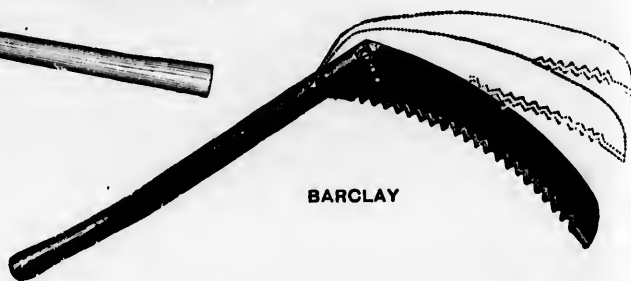

BARCLAY

Eureka Corn Knives..... per doz. 3.20
 Barclay "..... " 5.70

HAY KNIVES



LIGHTNING



HEATH'S



T HANDLE

Improved Lightning Hay Knives, American Pattern	per doz.	12.50
Heath's ".....	"	15.00
T Handle ".....	"	12.00
L Handle ".....	"	12.00
Barclay ".....	"	12.00
".....	"	12.00
".....	"	12.00

GARDEN SHEARS

011 + 0070



No. 137

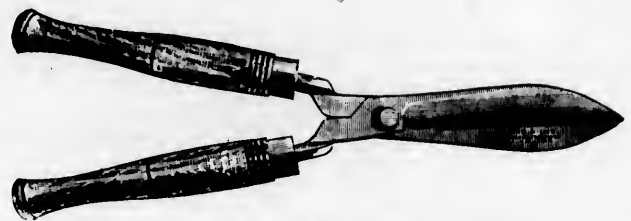

No. 134, GARDEN SHEARS WITH PRUNING NOTCH

Length of Cut	7½	8	8½	9	10	inch.
No. 133—Not Notched	per pair.	\$1.35	1.40	1.50	1.70
" 134—Notched	"	1.55	1.60	1.70	1.90	2.10
" 132—Ladies' Garden Shears, Length of Cut 8 inches.....	per pair.	\$1.50				
Length of Cut		9				inches.
No. 137—Long Handle Border Shears	per pair.	2.55				
" 139— " Grass "	"	2.55				

TREE PRUNERS

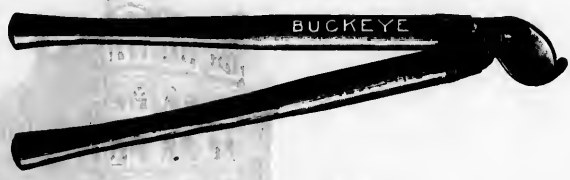

BUCKEYE TREE PRUNERS

Length of Handle.....		26	30	inch.
No. 1—1½ inch Cut.....	each.	1.25	
" 2—2 "	"	2.00	

ENGLISH BRANCH SHEARS

Length of Handle.....		30	36	inch.
No. 131-2—2½ inch Cut.....	each	2.95	
" 131-3—3 "	"	3.35	



WATERS' PATTERN

Waters' Pattern, 6, 8 or 10 feet Handle 740 per doz. 16.00

doz. \$3.00

doz. 3.20
5.70

doz. 12.50
15.00
12.00
12.00
12.00

01170

PRUNING SHEARS

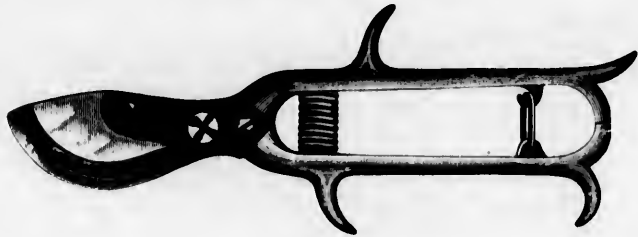

No. 2

No. 2—Pruning and Sheep-Toe Shear, with Spiral Brass Spring, Length 9 inches per doz. \$7.50



No. 1636



No. 7191



No. 7210

Length	7½	8	8½	9 inch.
No. 1636—Black, Steel..... per doz.		\$6.00	0.50	7.10
" 7191— " Forged Steel..... "		6.00	7.10	7.70
" 7210— " "	6.00
Extra Springs for Nos. 1636 or 7191 Shears..... per doz.				0.75

FRUIT GATHERER

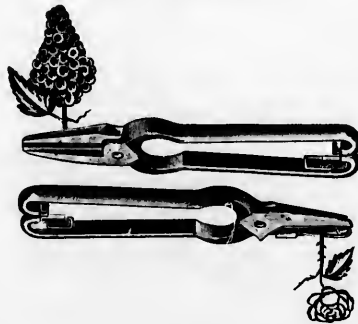

No. 1—Fruit or Flower Gatherer..... per doz. 5.00

Length
No. 11
" 11

Length
No. 3—
" 4—

No. 1002
" 1002
"
"

No. 1003

SHEEP SHEARS

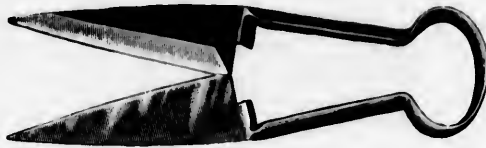

Length.....		11	12 inch.
No. 1500 - Boker's, Bent, Half Polished.....	per doz.	\$3.00	
" 1501 - " " " Better Quality.....			4.50



Length of Blade.....		6	6½ inch.
No. 3 - Bent, Half Polished.....	per doz.	9.00	
" 4 - " " ".....			10.50

GARDEN TROWELS



No. 1002

No. 6

No. 1002 - Forged Steel, Socket, 6 inch Blade, Half Polished, balance of Blade and Socket Blued, Polished Beech Handle.....	per doz.	3.30
" 1002½ - Forged Steel, as No. 1002, only with long Handle, 16 inches.....		3.70
" 6 - Plain Steel, Bright 6 inch Blade.....		1.00
" 2 - Angle Trowel, " 7 " ".....		4.70
" 3 - " " " 5 " " for Pot use.....		2.70

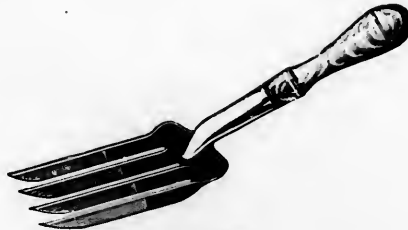

No. 1003½

No. 1003½ - Forged Steel, Socket, 4½ inch Blade, Half Polished, balance blued, polished Beechwood Handle.....	per doz.	4.50
--	----------	-------------

\$7.50

9 inch.
7.10
7.70
.....
0.75

doz. 5.00

GARDEN REELS AND HOOKS

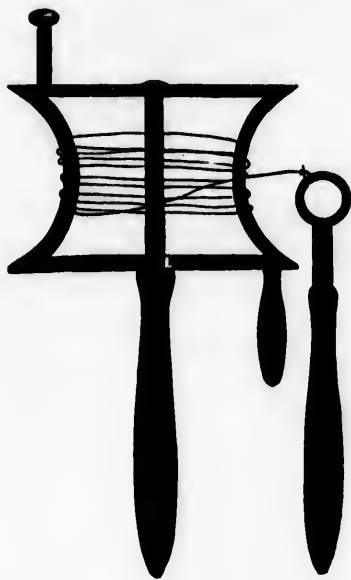

No. 1



No. 2

No. 1—Garden Line Reels, Malleable Iron, Japanned per doz. \$11.50
 " 2— " Hook or Nail Claw, Malleable Iron, Japanned, Wood Handle " 3.00

ORNAMENTAL LAWN VASES



No. 2



Nos. 6 and 7 with Base

No. 2—Vase only, Height 20 inches, Diameter of Top 16 inches each 5.00
 " 3— " " 24 " " 24 " with Handles at Side " 8.35
 " 6—Vase and Base, Height 41 inches, Diameter of Top 16 inches, Width of Base 14 inches..... " 9.15
 " 7— " " 38 " " 38 " " 22 " " 25.00

FOUNTAINS

No. 67—Height 4 feet 6 inches, Diameter of Basin 4 feet each 75.00
 No. 67 Fountain is constructed of Vases Nos. 6 and 7 extended, Ornamental Basin attached at Base.

CHAFF KNIVES

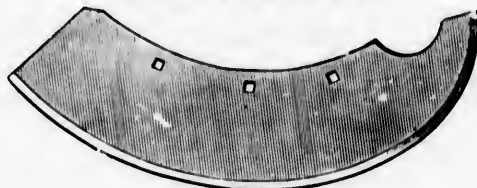

No. 4—Cast Steel.....per doz. \$16.20

CORN PLANTERS



"King of the Field" Corn Planters, with Flexible Iron Drop, Iron Seed Box and Channel.....per doz. \$ 14.00

CORN HUSKERS

STANDARD



No. 1



No. 2

No. 1—Full Leather, Covering Palm and Back of Hand, Nickel-Plated Steel Palm.....per doz. 8.00
 " 2—Same as No. 1 but with Steel Band in place of Full Steel Palm " 7.00



No. 3

No. 3—Leather Palm only, Back Straps, Steel Band as in No. 2per doz. 4.00
 One dozen in a box.

doz. \$11.50
 3.00

each 5.00
 " 8.35
 " 9.15
 " 25.00

each 75.00
 Base.

CORN HUSKERS



No. 2000



No. P



No. E

- No. 2000—Steel Pin, Split Calf, or Kip Stock per doz. \$1.00
 " P—Tinned Steel Pin, Best Calf Strappings " 1.50
 " E— " " Adjustable, can be used over Glove " 4.70
 Nos. 2000 and P three dozen in a Box, No. E one dozen.



No. R



No. O



No. 9

- No. R—Tinned Steel Pin, Heavy Calf Cot, Protected by Steel Rivets per doz. \$2.50
 " O— " " Combination Thumb and Finger Cots, Protected by Steel Rivets 5.50
 " 9— " " Moleskin Stock, Protected by Tinned Steel Rivets per doz. pairs. 10.50
 Nos. R and O one dozen in a Box, No. 9 one dozen pairs.



No. 4RC



No. 21X



- No. 4RC—Tinned Steel Pin, Brown Colored Calf Skin, Protected by Tinned Steel Rivets per doz. pairs. 22.50
 " 21X—Buckle Wrist Bands, No. 2 Calf Stock, Brass Buckles per doz. 1.80
 No. 4RC half-dozen pairs in a Box, No. 21X one dozen bands.

COTTON FLANNEL MITTENS

- No. 81—Best 8 oz. Grey Duck, Tipped Palm and Thumb per doz. pairs. 1.80
 " 70— " 8 " Cotton Flannel, with Double Palm and Thumb " " 2.20
 " 27— " 8 " " Double Palm and Leather Thumb, also Strap on Wrist " " 2.80

HARVEST MITTS

- | Length | | 10 | 11 |
|---|-----------------|--------|------|
| | per doz. pairs. | \$3.20 | 3.70 |
| No. 21—Sheep Skin, with Thumb and Finger, Flesh Side Out | | 4.00 | 4.20 |
| " 22— " Tanned, with Thumb and Finger | | 4.40 | 4.50 |
| " 23— " Heavy, with Thumb and Finger | | 4.80 | 5.30 |
| " 24—Excelsior Waterproof, Chrome Tanned, with Thumb and Finger | | | |
| " 25—Saranac, with Black Top, Thumb and Finger, 11½ inch | per doz. pairs. | \$6.00 | 4.00 |
| " 26—Sheep Skin, without Finger, 10 inch | | | 4.80 |
| " 27—Saranac, " 10 " | | | 7.20 |
| " 28—Harvest Gloves, Sheep Skin, 10 " | | | |

THRESHER OR BINDING MITTS

- | | | |
|---|-----------------|-------|
| No. 10—15 inch, Sheep Skin, with Finger and Thumb | per doz. pairs. | 6.50 |
| " 11—15 " Chrome Body, with Sheep Skin Top, with Finger and Thumb | | 8.50 |
| " 12—17 " All Sheep Skin, Heavy, with Finger and Thumb | | 10.50 |
| " 13—15 " Saranac Body, Sheep Skin Top, with Finger and Thumb | | 15.00 |
| " 14—15 " Sheep Skin, with Buckskin Facing, with Finger and Thumb | | 16.00 |

No. 1
" 4
" 6

No. 20
" 40
" 60

No. 25
" 44
" 64

No. 26
" 45L
" 64
" 65
" 114

SQUARE POINT SHOVELS



211+11075

Patent Plain Back, D Handle.

No. 20D—Jones', Solid Cast Steel, No. 2, Polished	per doz.	\$16.50
No. 20D, Black, \$0.25 net per dozen less.		
" 40D—Burns', Solid Cast Steel, No. 2, Polished	"	15.00
No. 40D, Black, \$0.25 net per dozen less.		
" 60D—Old's, Solid Steel, No. 2, Polished	"	12.50

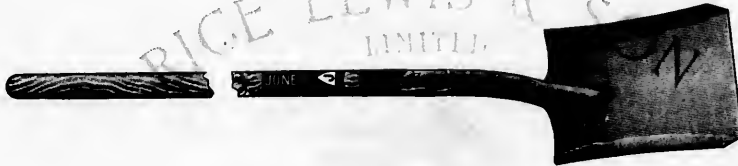

Patent Plain Back, Long Handle.

No. 20L—Jones', Solid Cast Steel, No. 2, Polished	per doz.	16.50
" 40L—Burns', " " " 2 "	"	15.00
" 60L—Old's, Solid Steel, No. 2, Polished	"	12.50

ROUND POINT SHOVELS



Patent Plain Back, D Handle.

No. 25—Jones', Solid Cast Steel, No. 3, Polished	per doz.	17.00
No. 25, Black, \$0.25 net per dozen less.		
" 44—Burns', Solid Cast Steel, No. 3, Polished	"	15.50
No. 44, Black, \$0.25 net per dozen less.		
" 64—Old's, Solid Steel, No. 2, Polished	"	12.50



Patent Plain Back, Long Handle.

No. 26 —Jones', Solid Cast Steel, No. 2, Polished	per doz.	16.50
" 46L—Burns', " " " 2 "	"	15.00
" 64 —Old's, " Steel, No. 2, Polished	"	12.50
" 65 —Old's, " " (Narrow), No. 2, Polished	"	12.50
" 114 —Eley's, Miners' Shovels, Cast Steel, Riveted Back Strap, Polished, Spring Point	"	13.50

D HANDLE SPADES



Patent Plain Back.

No. 24D—Jones', Solid Cast Steel, No. 2, Polished	per doz.	\$16.50
" 43D—Burns', " " " 2, "	"	15.00
" 47 — " Toy Spades	"	11.00
" 63D—Old's, Solid Steel, No. 2, Polished	"	12.50

LONG HANDLED SPADES

No. 24L—Jones', Solid Cast Steel, No. 2, Polished	per doz.	16.50
" 43L—Burns', " " " 2, "	"	15.00
" 63L—Old's, Solid Steel, No. 2, Polished	"	12.50

POST HOLE SPADES



Patent Plain Back, D Handle.

No. 155—Jones', Solid Cast Steel, Polished, 15×5½×6 inch, (Concave).....	per doz.	14.00
--	----------	-------

CLAY SPADES



Patent Plain Back, D Handle.

No. 156—Jones', Solid Cast Steel, Polished, 12½×7 inch.....	per doz.	14.00
---	----------	-------

DITCHING SPADES



No. 154—Jones', Solid Cast Steel, Polished, 15½×7½×5½ inch, (Flat).....	per doz.	14.00
---	----------	-------

No. 11
" 12
" 13
" 14

No. 649
" 650
" 651
" 652

No. 172

No. 3—Cas
" 4—
" 5—
" 6—

DRAINING SPADES



Patent, Solid Plain Back.

z.	\$16.50 15.00 11.00 12.50	No. 151—Jones', Solid Cast Steel, No. 2, Heavy, Polished, 17 x 5½ x 4¼ inches.....	per doz.	\$14.00
		" 152— " " " 3, " " " 17 x 4½ x 3 "	"	14.00
		" 161—Burns', " " " 2, Light, " " 17 x 5¼ x 4¼ "	"	13.00
		" 162— " " " 3, " " " 17 x 4½ x 3 "	"	13.00

RICE LEWIS & SON
LIMITED
ENGLISH DRAINING SPADES



Solid Cast Steel.

z.	16.50 15.00 12.50	No. 649—Argyle & Co.'s, Solid Cast Steel, Strapped, ¾ Bright, 17 x 6 x 3¼ inches.....	per doz.	18.40
		" 650— " " " " Bright, 17 x 6 x 3¼ "	"	25.75
		" 651—A. F. Parkes & Co.'s, Solid Cast Steel, Strapped, ¾ Bright, 18 x 6 x 3¼ inches.....	"	23.00
		" 652— " " " " Bright, 18 x 6 x 3¼ "	"	20.00

POST HOLE SPOONS



Noz.	14.00	No. 172—Cast Steel, Riveted Spoon, Black	per doz.	10.50
------	-------	--	----------	-------

CONCAVE DRAIN CLEANERS

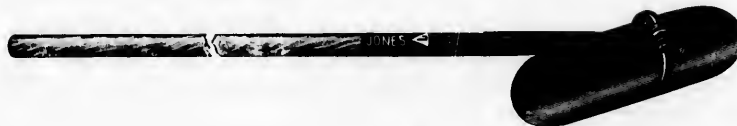

ADJUSTABLE

Noz.	14.00	No. 3—Cast Steel Blade, 3 x 15 inch, with Malleable Iron Socket, made to Push or Pull.....	per doz.	14.35
		" 4— " " 4 x 15 " " " " " " "	"	14.35
		" 5— " " 5 x 15 " " " " " " "	"	14.85
		" 6— " " 6 x 15 " " " " " " "	"	14.35

WIRE STRETCHERS



HERCULES

Hercules Wire Stretchers *170* per doz. \$3.35

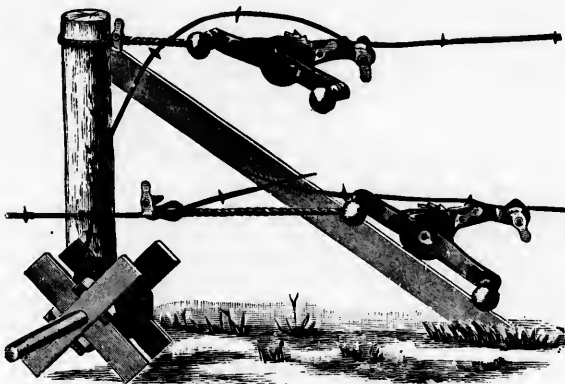

SAMSON

Samson, Wire Stretchers, with Two Handles, Self Adjusting *200* per doz. 12.95

REVOLVING CLOTHES REEL IRONS



No. 1—Japanned, Round Base, 4½ inch Diameter, for 4 arms	per doz.	10.65
" 2—Painted Black, " 5 " " " 4 " Braced	"	16.65
" 3— " Square Base, 4 x 4 inch, " 4 " "	"	16.65

No. 1—St
" 2—W

No. 3—Pa

No. 104—Su

TUBULAR STEEL WHEELBARROWS



DIRT BARROW

No. 4—Tray 15 Gauge Steel, Weight of Barrow 70 lbs., Capacity 8 cubic feet each \$10.75
 " 5— " 14 " " " 78 lbs., " 4 " " " " 13.50



COAL BARROW

No. 7—Tray 14 Gauge Steel, Weight of Barrow 88 lbs., Capacity 4 cubic feet..... each 14.25

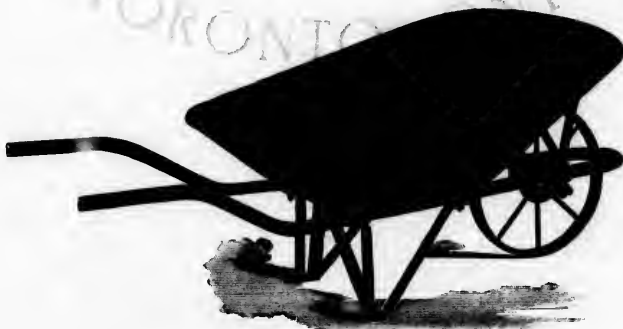

COAL AND COKE BARROW

No. 10—Tray 13 Gauge Steel, Weight of Barrow 100 lbs., Capacity 6 cubic feet each 20.00

z. \$29.65
 32.10

doz. 43.20
 45.35
 47.50

o. 13
 r doz. 10.00
 " 12.75
 es 13 1/2
 r doz. 17.50

STEEL DRAG SCRAPERS



No. 30—Contains about 5 Cubic Feet of Earth, Weight about 70 lbs each \$7.25



No. 31—Contains about 7 Cubic Feet of Earth, Weight about 135 lbs each 9.00
 " 32— " 6 " " 120 " " 8.10
 Made of Solid Sheet Steel, Pressed into Shape.

WHEELED SCRAPER



No. 4—Self Loading and Dumping Cart, carries 11 Cubic Feet of Earth each 54.00
 " 5— " 15 " " " " 63.00
 With Latest Improved Irons and Sand Proof Boxing, No. 4 Weighs about 450 lbs., No. 5, 600 lbs.

No. 6—J

2 1/2 x 8 1/2 inc
 5 1/2 x 8 1/2 "
 2 1/2 x 8 1/2 "
 5 1/2 x 8 1/2 "

Diameter ...
 No. 333—E

Kept in Stock

FOOT SCRAPERS

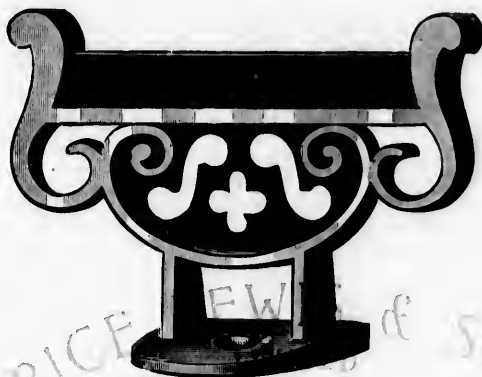

No. 6. Half size cut.

No. 6—Japanned per doz. \$1.80
 Half-dozen in box.

VENTILATING AIR BRICK

With Sliding Plate.



2 1/2 x 8 1/2 inch, With Slide..... per doz. \$4.00
 5 1/2 x 8 1/2 " " " " " " 7.20
 2 1/2 x 8 1/2 " Without Slide..... " " 3.00
 5 1/2 x 8 1/2 " " " " " 4.80

CAST IRON STAIR PLATES

To Screw to Wood Steps.



No. 70—16 1/2 x 8 inch, With Round Nose for Lapping over..... each 0.60
 " 71—33 1/2 x 7 1/2 inch, Flat..... " 1.10

VAULT LIGHT GRATINGS

For Areas, Roofs and Floors.

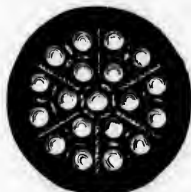

No. 333
 CIRCULAR

Diameter 18 20 24 inch.
 No. 333—Each..... \$7.20 10.80 18.00

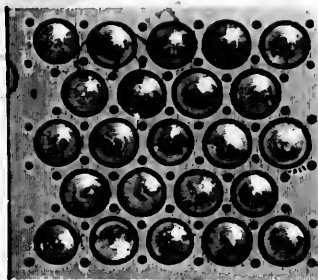

No. 334
 SQUARE

No. 334—Per Square Foot..... 4.80

LIGNUM-VITÆ

Kept in Stock in Sticks 4 to 10 inches in Diameter..... per lb. 0.10

STORE SEATS



No. 50

- No. 50—To Fasten to Side of Counter, Seat and Bracket Folds Close to Counter, Complete with Bracket each \$4.20
 " 55—To Fasten to Floor, with Swivel Seat..... " 1.00



No. 55

REGISTERING TURNSTILES

For Exhibition Purposes.

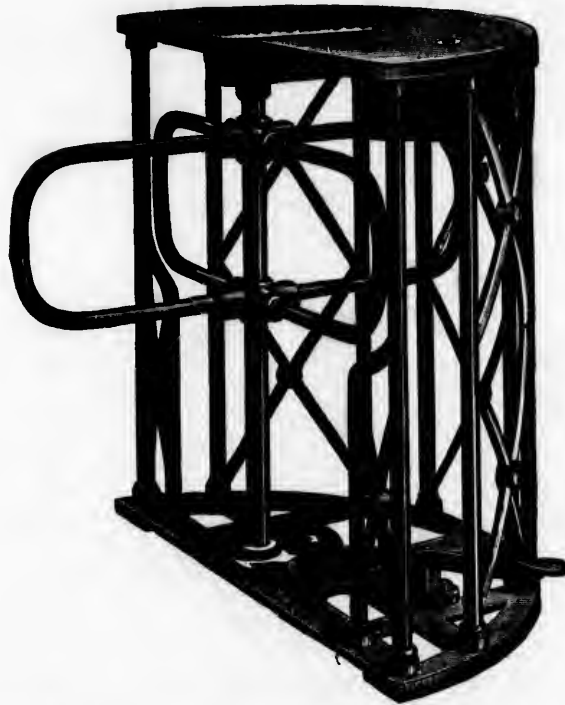

Registering Turnstiles, Complete with Lock, Indicators and Cast Iron Cash Drawer each 144.00

W
 Push, 3
 Pull, 3

Push, 3
 Pull, 3

White

No Admi
 Lavatory
 Ladies
 Gentleme
 No Road
 Size, 10 x
 No Admit

To fasten
 with your foot

FOR DWE
 L

No. 1—Japs
 " 2—Old
 " 3—Bron
 " 4—Solid

DIREC
 lower edge o

ENAMELLED SIGNS



OVAL

White Ground, Blue Letters, Tipped, Hollowed.

Push, 2 x 3 inch.....each \$0.50
 Pull, 2 x 3 "....." 0.50



OBLONG

White Ground, Blue Letters, Tipped.

Push, 3 x 1 1/2 inch.....each \$0.10
 Pull, 3 x 1 1/2 "....." 0.40



OBLONG, OVAL ENDS

White Ground, Blue Letters, Lined and Tipped, Hollowed.

No Admittance	Office	Men
Lavatory	Private	Women
Ladies	Refreshments	Exit
Gentlemen	Fresh To-Day	Please Shut the Gate
No Road	Fire Escape	

Size, 10 x 2 1/2 inch.....each \$0.50
 No Admittance, size 14 x 3 inch....." 0.90



OBLONG, FIGURED ENDS

White Ground, Blue Letters, Lined and Tipped.

Smoking Room	Private Office
Dining Room	Ladies' Toilet
Waiting Room	Men's Toilet
Baggage Room	General Waiting Room
Men's Waiting Room	Lunch Room
Ladies' Waiting Room	Agent's Office
Telegraph Office	No Admittance
Ticket Office	Freight Office

Size, 23 x 3 1/2 inch.....each \$0.80



OBLONG, SQUARE ENDS

White Ground, Blue Letters, Lined and Tipped.

Stick No Bills	Furnished Apartments
Smoking Prohibited	Please Shut the Door

Size, 18 x 3 1/2 inch.....each 0.70

PERPENDICULAR, SQUARE ENDS

White Ground, Blue Letters, Lined and Tipped.

Push	Pull
------	------

Size, 12 x 3 inch, Letters Horizontal or Perpendicular.....each 0.80

LE PAGE'S PATENT LOWER DOOR CHECKS

For Holding Doors Open.

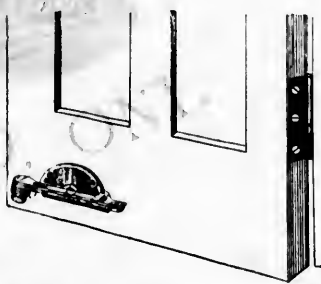
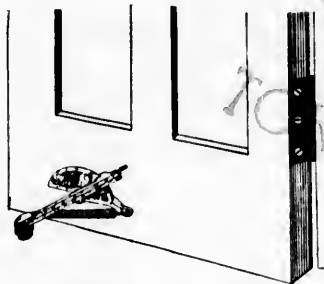

To fasten the door at any point, push down front end of Holder with your foot as above.

To release the door, push down back end of the Holder until you bring it to a horizontal position as above.

FOR DWELLING HOUSES AND LIGHT DOORS

	Per doz.
No. 1—Japanned.....	\$4.20
" 2—Old Copper Finish....	6.00
" 3—Bronze-Plated.....	6.00
" 4—Solid Bronze.....	9.00

FOR BANKS, HOTELS AND MEDIUM DOORS

	Per doz.
No. 5—Japanned.....	\$6.00
" 6—Old Copper Finish....	9.00
" 7—Bronze-Plated.....	9.00
" 8—Solid Bronze.....	12.00

FOR EXTRA HEAVY DOORS

	Per doz.
No. 9—Japanned.....	\$12.00
" 10—Bronze.....	18.00
" 11—Old Copper Finish..	18.00

DIRECTIONS FOR APPLYING.—Numbers 1 to 4, 2 1/2 inches, Nos. 5 to 8, 2 1/2 inches, Nos. 9 to 11, 3 inches from lower edge of check to floor. If to hold on carpet, 1/4 inch lower for all sizes.

WATCHMAN CONTROL CLOCKS

MYER'S

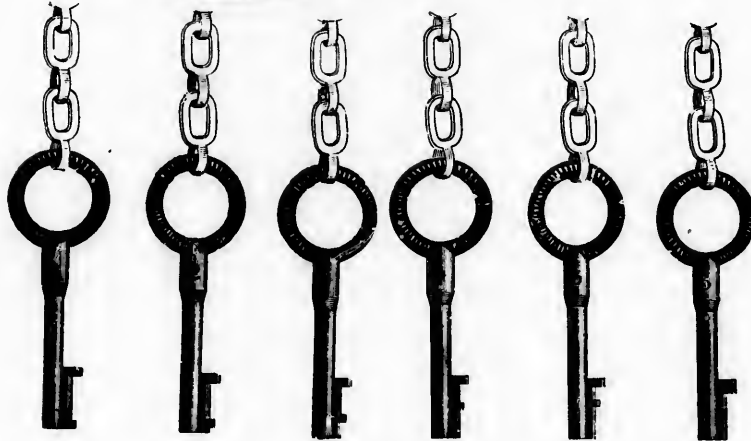
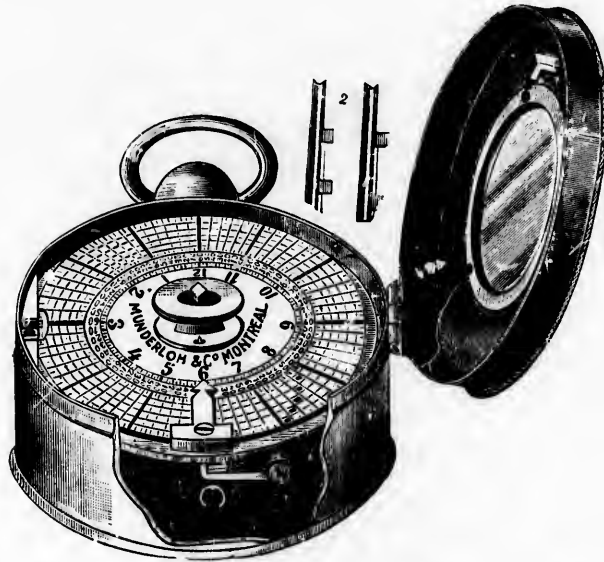

Clock, with Latest Improvements, including 6 Keys, 400 Dials, and Leather Pouch each \$52.50

The newest improvement in the Clock is a small knife attached to the lid, which, on closing, makes an incision in the paper dial, thus showing how often the Clock has been closed, and prevents it from being tampered with without being detected. The Clock is portable, and of simple construction, at the same time a perfect time piece, and of such durable workmanship that it will last a lifetime. Full instructions with each Clock.

No.
they
air t
occe

No. 3
" 3
" 4

with
inches

No. 3
" 4

ROOT'S ACME HAND BLOWER

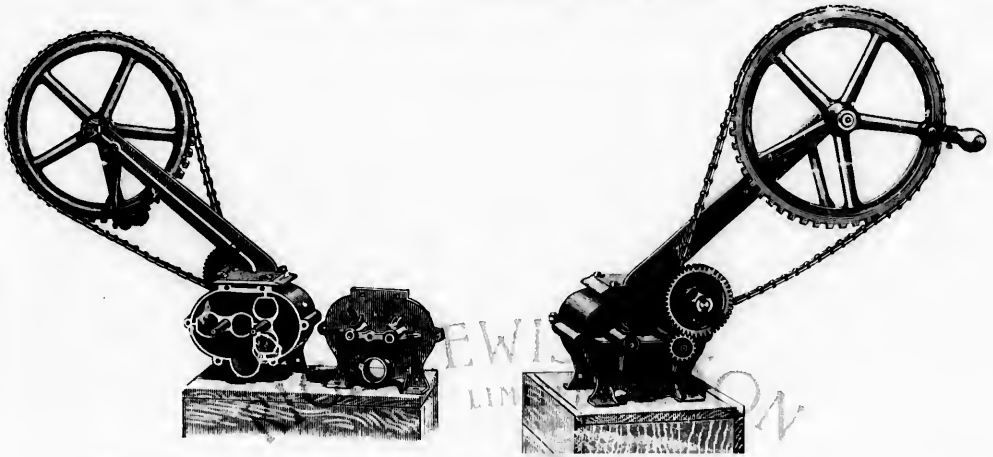

CUT SHOWS REVOLVERS EXPOSED TO VIEW

No. 3

No. 3—Suitable for Ordinary up to Largest Class Fire, gives a blast equal to 60 inch Bellowseach \$25.50

ADVANTAGES.—The Revolvers are enclosed in an iron case, bored out perfectly true, and are dressed so that they keep up continuous contact with each other during the entire revolution, forcing forward and utilizing all the air taken into the case. The shafting is steel, the bearings phosphor bronze, the gears are cut. The Blower occupies a space less than a foot square of floor surface.

ROOT'S ACME POWER BLOWER

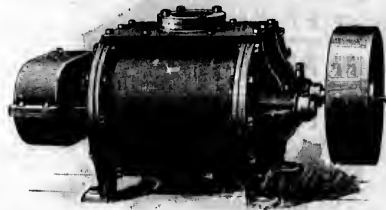

No. 3	—Capacity per Revolution, 172 cubic inches, Outlet 1½ inches, Weight 87 lbs.....	each	\$24.00
" 3½	— " " " 325 " " 2 " " 98 "	"	45.00
" 4	— " " " 648 " " 3 " " 188 "	"	90.00

DIMENSIONS.—No. 3, 10 x 10½ x 16 inches; No. 3½, 10 x 14 x 18 inches; No. 4, 12 x 16 x 26 inches. No. 4 is made with top or side discharge. Pulley on No. 3, 5½ x 1½ inches; pulley on No. 3½, 8 x 2 inches; pulley on No. 4, 10 x 3 inches.

FIRE BED AND TUYERE



For use in Brick Forge.

No. 3	—14½ inches square, 11½ inches deep, weight 63 lbs.....	each	\$6.30
" 4	—18 " " 12 " " 80 "	"	7.50

Per Iron
L. O. Price

BAR IRON AND STEEL

DOMINION SCHEDULE OF EXTRAS IN BAR IRON AND STEEL, ADOPTED JULY 7th, 1897.

Extras per 100 lbs.

BARS.	3/16	1/4	5/16	3/8	7/16	1/2	9/16	5/8	11/16	3/4	7/8	1	1 1/4 in.
Small, Round and Square.....	\$1.25	0.90	0.45	0.35	0.25	0.15	0.15	0.05	0.05
" Flat..... 1/2 inch	1.00	0.75	0.75	0.75	0.75
" "..... 3/4 "	0.75	0.60	0.60	0.45	0.45
" "..... 1 "	0.60	0.45	0.45	0.30	0.30	0.30	0.30	0.30
" "..... 1 to 6 "	0.45	0.35	0.35	0.30	0.30	0.30	0.30	0.30	0.30
Oval.....	0.30	0.15	0.15
Half Oval and Half Round.....	1.00	1.00	0.80	0.80	0.60	0.60	0.45	0.30	0.30	0.30

LARGE ROUND AND SQUARE			
Extras per 100 lbs.			
2 1/4 to 2 3/4 inch....	\$0.05	4 inch....	\$0.60
3 inch.....	0.20	4 1/2 "....	0.75
3 1/2 ".....	0.30	5 "....	1.20
3 3/4 ".....	0.40	5 1/2 "....	1.50
3 7/8 ".....	0.50	6 "....	2.00
		6 1/2 "....	2.50
		7 "....	3.00

LARGE FLAT							
Extras per 100 lbs.							
INCHES.	3 to 6	7	8	9	10	11	12
1/2 and 1 1/8	\$0.15	0.40	0.50	0.60	0.70	0.80	0.90
1/4 to 1	0.25	0.40	0.50	0.60	0.70	0.80
1 1/8 to 2	0.15	0.40	0.50	0.60	0.70	0.80	0.90

CUTTING TO SPECIFIC LENGTHS

When Rolling \$0.10 per 100 lbs. extra. Lengths over 20 feet special.

REGULAR BASE SIZES, NOT EXTRAS

Round or Square Iron.....	3/4 to 2 inches.
Flat Iron.....	1/2 to 4 inches x 1/2 to 1 1/2 "
" ".....	1/2 to 6 " x 1/2 to 1 "

Best refined Horse Shoe Iron \$0.25 on corresponding price of common iron.

EXTRAS ON BAND IRON

No. 10 Gauge.

Size.....	1/2	5/8	3/4	7/8	1 to 6 inch.
Per 100 lbs.....	\$2.00	1.30	0.70	0.50	0.30

Over 7 inches wide at special price but not less than \$0.60 per 100 lbs.

No. 12 Gauge.

Size.....	3/8	1/2	5/8	3/4	7/8	1	1 1/8	1 1/4	1 1/2	1 3/4	2 inch.
per 100 lbs.....	\$.....

HOOP STEEL

Size.....	1/2 x 22	1/2 x 24	5/8 x 20	5/8 x 22	3/4 x 21	7/8 x 19	1 to 1 1/4	1 1/2 to 3 inch.
Per 100 lbs.....	\$.....

DRAWN RODS

Size.....	3/16	7/32	1/4	5/32	5/16	3/8	7/16	1/2 inch
Per 100 lbs.....	\$.....

LOWMOOR IRON

Round or Square.....	1/4	5/16	3/8	7/16	1/2	5/8	3/4	7/8	1 inch.			
Per 100 lbs.....	\$.....			
Round or Square.....	1 1/8	1 1/4	1 3/8	1 1/2	1 3/4	2	2 1/4	2 1/2	2 3/4	3 inch.		
Per 100 lbs.....		
Flat.....	1 x 7	1	1 1/8	1 1/4	1 1/2	1 3/4	2	2 1/4	2 1/2	2 3/4	3 inch.	
Per 100 lbs.....	
Flat.....	1 x 8	1	1 1/8	1 1/4	1 1/2	1 3/4	2	2 1/4	2 1/2	2 3/4	3 inch.	
Per 100 lbs.....	
Flat.....	1 x 1 1/2	1 1/4	2	2 1/4	2 1/2	3	3 1/2	4	4 1/2	5	5 1/2	6 inch.
Per 100 lbs.....

SWEDES AND NORWAY IRON

Round or Square.....	1/4	5/16	3/8	7/16	1/2	5/8	3/4	7/8	1	1 1/8	1 1/4	1 1/2 inch.
Per 100 lbs.....	\$.....
Flat.....	3/8 x 1	1 1/8	1 1/4	1 1/2	1 3/4	2	2 1/4	2 1/2	2 3/4	3	3 1/2	4 inch.
Per 100 lbs.....

897.

1	1 1/4 in.
30	0.30
40	0.40

11	12
0.80	0.90
0.70	0.80
0.80	0.90

3/4 to 2 inches.
to 1 1/4
to 1

1 to 6 inch.
0.90

3/4 2 inch.

1 1/2 to 3 inch.

1/2 inch

1 inch.

3 inch.

2 1/2 2 3/4 inch.

2 1/2 3 inch.

3 3 1/2 4 inch.

1 1/4 1 1/2 inch.

1 1/4 1 1/2 inch.

ANGLE STEEL

Equal Sides.

Size..... 3/8 x 3/4 7/8 1 1 1/8 x 1 1/8 1 1/4 1 1/2 1 3/4 x 1 1/4 1 1/2 1 3/4 2 2 1/4 2 1/2 3 inch.
Price per 100 lbs. \$

Size..... 3/8 x 2 2 1/4 2 1/2 3 3 1/2 4 1/2 x 3 3 1/2 4 5 "
Price per 100 lbs. \$

TEE STEEL

Size..... 1 x 1 x 1/2 1 1/4 x 1 1/4 x 3/8 1 1/2 x 1 1/4 x 3/8 2 x 1 1/2 x 1/4 2 1/2 x 2 1/2 x 5/8 "
Price per 100 lbs. \$

Size..... 3 x 2 1/2 x 5/8 3 1/2 x 3 x 5/8 3 1/2 x 3 x 1/2 4 x 3 x 5/8 5 x 3 x 5/8 "
Price per 100 lbs. \$

SLEIGH SHOE STEEL

Size..... 3/8 x 7/8 1 1 1/8 1 1/4 1 1/2 1 3/4 2 2 1/4 2 1/2 3 3 1/2 4 1/2 x 7/8 1 "
Price per 100 lbs. \$

Size..... 1/2 x 1 1 1/4 1 1/2 1 3/4 2 2 1/4 2 1/2 3 3 1/2 4 "
Price per 100 lbs. \$

Size..... 5/8 x 1 1/2 1 5/8 1 3/4 2 2 1/2 3 3 1/2 x 1 1/2 1 3/4 2 3 3 1/2 4 1 x 3 3 1/2 4 "
Price per 100 lbs. . . \$

* Stocked in 9 and 16 feet lengths, other sizes in 16 feet lengths only.

TOE CALK STEEL

Size..... 1/4 x 5/8 1/2 5/8 x 7/8 1/2 3/4 x 1/2 5/8 3/4 7/8 1 7/8 x 3/4 7/8 1 1/2 x 3/4 7/8 1 "
Price per 100 lbs. \$

TIRE STEEL, ROUND EDGE

Size..... 3/8 x 3/4 3/8 x 3/4 7/8 1 1/4 x 7/8 1 1 1/8 1 1/4 5/8 x 1 1 1/8 1 1/4 1 1/2 "
Price per 100 lbs. \$

Size..... 3/8 x 1 1/4 1 3/8 1 1/4 7/8 x 1 1/4 1 3/8 1 1/2 1/2 x 1 1/4 1 3/8 1 1/2 1 3/8 1 1/4 2 5/8 x 1 1/4 2 "
Price per 100 lbs. \$

SPRING STEEL

Size..... 1/2 x 1/2 to 3/4 1/2 x 3/4 to 1 3/8 x 1 to 1 1/2 3/8 x 3/4 to 7/8 3/8 x 1 to 1 1/2 "
Price per 100 lbs. \$

Size..... 1/4 x 3/8 to 3/4 1/4 x 7/8 to 1 1/4 x 1 1/4 inch and larger.
Price per 100 lbs. \$

ROUND SPRING STEEL

Size..... 1/4 5/16 3/8 7/16 1/2 5/8 3/4 inch.
Price per 100 lbs. \$

CULTIVATOR STEEL

Size..... 1/2 x 3 4 5 6 3/8 x 5 6 7 8 inch.
Price per 100 lbs. \$

HARROW TOOTH STEEL

Size, Square..... 1/8 3/8 1/2 inch.
Price per 100 lbs. \$

MACHINERY STEEL

ROUND

Size..... 3/16 1/4 5/16 3/8 7/16 1/2 5/8 3/4 13/16 7/8 1 1 1/16 1 1/8 1 1/4 1 1/2 1 5/8 1 3/4 inch.
Price per 100 lbs. \$

Size..... 1 7/8 2 2 1/8 2 1/4 2 3/8 2 1/2 2 3/4 3 3 1/4 3 1/2 3 3/4 4 4 1/4 4 1/2 4 3/4 5 5 1/2 6 6 1/2 7 inch.
Price per 100 lbs. \$

SQUARE

Size..... 3/8 7/16 1/2 5/8 3/4 7/8 1 1 1/8 1 1/4 1 1/2 1 5/8 1 3/4 2 inch.
Price per 100 lbs. \$

SHEET CAST STEEL

Sheets 12 inches wide, 6 feet long.

Gauge..... 8 to 20 21 to 26 27 to 30
Price per 100 lbs. \$

SHEET DECARBONIZED STEEL

Sheets 12 inches wide, 6 feet long.

Gauge..... 8 to 20
Price per 100 lbs. \$

BLACK SHEET IRON OR STEEL

Gauge..... 10 and 12 14 17 13 19 20 22 21 26 28
Price per 100 lbs. \$

STEEL PLATE

Thickness..... 3/16 1/4 to 5/8 inch.
Price per 100 lbs. \$

CIRCULAR STEEL HEADS

Size..... 1/4 to 1 1/2 inch.
Price per 100 lbs. \$

CAST STEEL

Thomas Firths & Sons.....	per lb.	\$....
Park's "Black Diamond" Brand.....		".....
" " "Silver" Brand.....		".....

FIRTHS' TWIST DRILL CAST STEEL

In 24 inch Lengths.

Size.....	1/4	17/64	1/32	19/64	5/16	23/64	11/32	29/64	3/8	25/64	19/32	27/64	7/16	21/64	13/32	31/64	1/2	17/32	9/16	19/32	inch.
Per lb.....	\$																				

Size.....	5/8	21/32	11/16	23/32	3/4	25/32	13/16	27/32	7/8	29/32	15/16	1	1 1/16	1 1/8	1 3/16	1 1/4	1 5/16	1 3/8	1 7/16	1 1/2	inch.
Per lb.....	\$																				

R MUSHETS SPECIAL STEEL

Square.....	1/4	5/16	3/8	7/16	1/2	5/8	3/4	7/8	1	1 1/8	1 1/4	1 1/2	inch.
Per lb.....	\$												

Flat.....	1/2 x 3/4	7/8	1	1 1/8	1 1/4	1 1/2	5/8 x 1 1/8	1 1/4	1 1/2	1 3/4	inch.
Per lb.....	\$										

Flat.....	3/4 x 1 1/4	1 1/2	1 3/4	2	7/8 x 1 1/2	1 3/4	1 x 2	inch.
Per lb.....	\$							

DIRECTIONS for treating "R Mushets Special Steel": Heat the Steel before cutting it into lengths as it cannot be cut when cold, it should be worked at fully the same heat as ordinary Lathe Tool Steel. The Tool should be heated at least half its length, gradually but thoroughly, so as to be quite ductile under the hammer, and should be forged and finished off at a good heat, avoid forging it too cold, when forged and shaped the tool should be cooled in the air only, remember that the steel while hot must be kept from water.

TRAM RAILS

For Saw Mill and other Yards.



T Rails, 12 lbs. per yard.....	per 100 lbs.	\$
--------------------------------	--------------	----

Larger sizes supplied to order.

STEEL CHANNELS AND BEAMS

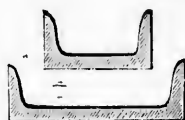

CHANNEL

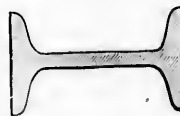

BEAM

STOCK SIZES, WEIGHTS AND LENGTHS

CHANNELS

Size.....	5 x 1 3/4	6 x 2 1/4	7 x 2 1/8	8 x 2 3/4	9 x 2 1/2	10 x 2 1/2	12 x 2 3/8	inch.
Weight per foot..	6 1/2	13	12 1/4	13 3/4	15	15	20 1/2	lbs.
Length.....	30	30	30	30	30	30	30	feet.
Per 100 lbs.....	\$							

BEAMS

Size.....	4 x 2 1/2	5 x 3	6 x 3 3/8	7 x 3 3/8	8 x 4	9 x 4	10 x 4 3/4	10 x 4 3/4	12 x 5	12 x 5	12 x 5	12 x 5	inch.
Weight per foot..	7 1/2	12 1/4	12 1/4	15	18	21	25	30	31 1/4	31 1/4	31 1/4	31 1/4	lbs.
Length.....	30	30	30	30	30	30	30	30	20	22	24	28	feet.

Size.....	12 x 5	12 x 5	12 x 6	12 x 6	12 x 6	12 x 6	15 x 5 1/2	15 x 5 1/2	15 x 5 1/2	15 x 5 1/2	inch.
Weight per foot..	31 1/4	31 1/4	40	43 1/4	40	40	42	42	42	42	lbs.
Length.....	32	36	20	24	28	32	30	20	24	28	feet.

Size.....	15 x 5 1/2	15 x 5 1/2	15 x 5 3/4	15 x 5 3/4	15 x 5 3/4	15 x 5 3/4	15 x 5 3/4	15 x 5 3/4	15 x 5 3/4	inch.
Weight per foot..	42	42	50	50	50	50	50	50	50	lbs.
Length.....	32	30	20	24	28	28	32	36	36	feet.
Per 100 lbs.....	\$									

Size...
Weight...

Size...
Weight...

10...
12...
14...
15...
16...
17...
18...
19...
20...
22...
24...

Size...
Gauge...
Iron...
Steel...
Copper...
Brass...

WEIGHTS AND TABLES

WEIGHT OF HALF ROUND AND OVAL IRON

Size.....	$\frac{3}{8} \times \frac{3}{16}$	$\frac{7}{16} \times \frac{3}{16}$	$\frac{1}{2} \times \frac{1}{4}$	$\frac{5}{8} \times \frac{3}{16}$	$\frac{3}{4} \times \frac{3}{8}$	$\frac{7}{8} \times \frac{7}{16}$	$1 \times \frac{1}{2}$	$1\frac{1}{8} \times \frac{3}{16}$	$1\frac{1}{4} \times \frac{3}{8}$	$1\frac{1}{2} \times \frac{3}{4}$
Weight per lineal foot..	.180	.233	.331	.517	.744	1.	1.32	1.62	2.	3.10s.

WEIGHT OF HALF OVAL IRON

Size.....	$\frac{3}{8} \times \frac{3}{16}$	$\frac{7}{16} \times \frac{3}{16}$	$\frac{1}{2} \times \frac{1}{8}$	$\frac{5}{8} \times \frac{3}{16}$	$\frac{3}{4} \times \frac{3}{16}$	$\frac{7}{8} \times \frac{3}{16}$	$1 \times \frac{1}{4}$	$1\frac{1}{8} \times \frac{3}{16}$	$1\frac{1}{4} \times \frac{3}{16}$	$1\frac{1}{2} \times \frac{3}{8}$
Weight per lineal foot..	.093	.13	.17	.26	.37	.50	.66	.81	1.	1.46 lbs.

STEEL HOOPS AND BANDS

Approximate weights in lbs. per lineal foot.

WIDTH.	$\frac{1}{2}$	$\frac{3}{8}$	$\frac{3}{4}$	$\frac{7}{8}$	1	1 $\frac{1}{8}$	1 $\frac{1}{4}$	1 $\frac{1}{2}$	1 $\frac{3}{4}$	2	2 $\frac{1}{4}$	2 $\frac{1}{2}$	2 $\frac{3}{4}$	3	3 $\frac{1}{2}$	4	4 $\frac{1}{2}$	5	6
B. W. G.																			
10.....	.227	.284	.341	.398	.455	.512	.569	.626	.683	.740	.797	.854	.911	.968	1.025	1.082	1.139	1.196	1.253
12.....	.185	.231	.278	.324	.370	.416	.463	.509	.555	.601	.647	.693	.739	.785	.831	.877	.923	.969	1.015
14.....	.141	.178	.211	.246	.282	.317	.352	.387	.423	.458	.493	.528	.563	.598	.633	.668	.703	.738	.773
15.....	.122	.153	.183	.214	.244	.275	.306	.337	.367	.398	.428	.458	.488	.518	.548	.578	.608	.638	.668
16.....	.110	.138	.165	.193	.221	.248	.276	.303	.331	.358	.386	.412	.439	.467	.494	.521	.548	.575	.602
17.....	.098	.123	.147	.172	.197	.221	.246	.270	.295	.319	.343	.367	.391	.415	.439	.463	.487	.511	.535
18.....	.088	.104	.125	.145	.166	.187	.208	.229	.249	.270	.291	.312	.332	.353	.374	.394	.415	.435	.456
19.....	.071	.089	.107	.125	.142	.160	.178	.196	.214	.232	.250	.268	.286	.304	.322	.340	.358	.376	.394
20.....	.059	.074	.089	.104	.119	.133	.148	.178	.208	.238	.267	.297	.327	.357	.387	.416	.445	.474	.503
22.....	.047	.059	.071	.083	.095	.107	.119	.142	.166	.190	.214	.238	.261	.285	.308	.333	.356	.380	.404
24.....	.037	.046	.056	.065	.074	.084	.093	.112	.130	.149	.168	.187	.205	.224	.241	.261	.280	.299	.318

WEIGHT OF ANGLE STEEL, EQUAL SIDES

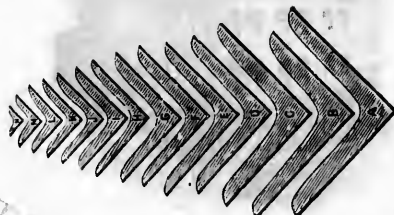

Weight per Foot in Pounds.

Size.....	$\frac{3}{4}$	$\frac{7}{8}$	1	1 $\frac{1}{4}$	1 $\frac{1}{2}$	1 $\frac{3}{4}$	2	2 $\frac{1}{4}$	2 $\frac{1}{2}$	2 $\frac{3}{4}$	3	3 $\frac{1}{2}$	4	5	6 inch.
$\frac{3}{4}$	0.0	0.7	0.8	1.0	1.2
$\frac{7}{8}$	0.8	1.0	1.2	1.5	1.8	2.1	2.5	2.8	3.1
1.....	1.5	1.9	2.4	2.8	3.2	3.7	4.1	4.5	4.9
1 $\frac{1}{4}$	2.4	2.9	3.4	4.0	4.5	5.0	5.5	6.1	7.1	8.2
1 $\frac{1}{2}$	3.4	4.0	4.7	5.3	5.9	6.6	7.2	8.5	9.8	12.3	14.8
1 $\frac{3}{4}$	4.6	5.3	6.1	6.8	7.6	8.3	9.8	11.3	14.3	17.2
2.....	6.8	7.7	8.5	9.1	11.1	12.8	16.2	19.6

WEIGHT OF 100 FEET IRON, BRASS, STEEL AND COPPER WIRE, IN POUNDS

Gauge.....No.	1	2	3	4	5	6	7	8	9	10	11	12	13	14	15	16	17	18	19	20
Iron.....	23.85	21.37	17.78	15.	12.82	10.92	8.58	7.21	5.89	4.75	3.81	3.14	2.39	1.82	1.37	1.12	.89	.69	.47	.32
Steel.....	24.67	21.57	17.94	15.15	12.05	11.	8.00	7.28	5.85	4.80	3.85	3.17	2.41	1.84	1.39	1.13	.90	.61	.47	.33
Copper.....	27.24	24.41	20.3	17.15	14.65	12.47	9.80	8.24	6.63	5.43	4.35	3.59	2.73	2.08	1.57	1.28	1.	.73	.53	.37
Brass.....	25.73	23.06	19.18	16.19	13.84	11.78	9.26	7.78	6.26	5.13	4.11	3.40	2.58	1.96	1.48	1.21	.96	.69	.50	.35

WEIGHT OF ROUND, SQUARE AND FLAT BAR IRON

Rounds		1/4	5/16	3/8	7/16	1/2	5/8	3/4	7/8	1	1 1/8	1 1/4	1 1/2	1 5/8	1 3/4	1 7/8	2	2 1/8	2 1/4	2 1/2	2 3/4	2 5/8	2 3/4	3	3 1/8	3 1/4	3 1/2	3 3/4	3 5/8	3 3/4	4	4 1/8	4 1/4	4 1/2	4 3/4	4 5/8	5	5 1/8	5 1/4	5 1/2	5 3/4	5 5/8	6	6 in. dia.																																																																																																																																																																																																																																																																																																																																																																																																																																																																																																																																																																																																																																																																																																																																																																																																																																																																																																																																																																																																													
1 foot	16 feet	1.63	2.55	3.68	5.0	6.54	8.28	1.02	1.23	1.47	1.72	2.01	2.31	2.61	2.91	3.21	3.51	3.81	4.11	4.41	4.71	5.01	5.31	5.61	5.91	6.21	6.51	6.81	7.11	7.41	7.71	8.01	8.31	8.61	8.91	9.21	9.51	9.81	10.11	10.41	10.71	11.01	11.31	11.61	11.91	12.21	12.51	12.81	13.11	13.41	13.71	14.01	14.31	14.61	14.91	15.21	15.51	15.81	16.11	16.41	16.71	17.01	17.31	17.61	17.91	18.21	18.51	18.81	19.11	19.41	19.71	20.01	20.31	20.61	20.91	21.21	21.51	21.81	22.11	22.41	22.71	23.01	23.31	23.61	23.91	24.21	24.51	24.81	25.11	25.41	25.71	26.01	26.31	26.61	26.91	27.21	27.51	27.81	28.11	28.41	28.71	29.01	29.31	29.61	29.91	30.21	30.51	30.81	31.11	31.41	31.71	32.01	32.31	32.61	32.91	33.21	33.51	33.81	34.11	34.41	34.71	35.01	35.31	35.61	35.91	36.21	36.51	36.81	37.11	37.41	37.71	38.01	38.31	38.61	38.91	39.21	39.51	39.81	40.11	40.41	40.71	41.01	41.31	41.61	41.91	42.21	42.51	42.81	43.11	43.41	43.71	44.01	44.31	44.61	44.91	45.21	45.51	45.81	46.11	46.41	46.71	47.01	47.31	47.61	47.91	48.21	48.51	48.81	49.11	49.41	49.71	50.01	50.31	50.61	50.91	51.21	51.51	51.81	52.11	52.41	52.71	53.01	53.31	53.61	53.91	54.21	54.51	54.81	55.11	55.41	55.71	56.01	56.31	56.61	56.91	57.21	57.51	57.81	58.11	58.41	58.71	59.01	59.31	59.61	59.91	60.21	60.51	60.81	61.11	61.41	61.71	62.01	62.31	62.61	62.91	63.21	63.51	63.81	64.11	64.41	64.71	65.01	65.31	65.61	65.91	66.21	66.51	66.81	67.11	67.41	67.71	68.01	68.31	68.61	68.91	69.21	69.51	69.81	70.11	70.41	70.71	71.01	71.31	71.61	71.91	72.21	72.51	72.81	73.11	73.41	73.71	74.01	74.31	74.61	74.91	75.21	75.51	75.81	76.11	76.41	76.71	77.01	77.31	77.61	77.91	78.21	78.51	78.81	79.11	79.41	79.71	80.01	80.31	80.61	80.91	81.21	81.51	81.81	82.11	82.41	82.71	83.01	83.31	83.61	83.91	84.21	84.51	84.81	85.11	85.41	85.71	86.01	86.31	86.61	86.91	87.21	87.51	87.81	88.11	88.41	88.71	89.01	89.31	89.61	89.91	90.21	90.51	90.81	91.11	91.41	91.71	92.01	92.31	92.61	92.91	93.21	93.51	93.81	94.11	94.41	94.71	95.01	95.31	95.61	95.91	96.21	96.51	96.81	97.11	97.41	97.71	98.01	98.31	98.61	98.91	99.21	99.51	99.81	100.11	100.41	100.71	101.01	101.31	101.61	101.91	102.21	102.51	102.81	103.11	103.41	103.71	104.01	104.31	104.61	104.91	105.21	105.51	105.81	106.11	106.41	106.71	107.01	107.31	107.61	107.91	108.21	108.51	108.81	109.11	109.41	109.71	110.01	110.31	110.61	110.91	111.21	111.51	111.81	112.11	112.41	112.71	113.01	113.31	113.61	113.91	114.21	114.51	114.81	115.11	115.41	115.71	116.01	116.31	116.61	116.91	117.21	117.51	117.81	118.11	118.41	118.71	119.01	119.31	119.61	119.91	120.21	120.51	120.81	121.11	121.41	121.71	122.01	122.31	122.61	122.91	123.21	123.51	123.81	124.11	124.41	124.71	125.01	125.31	125.61	125.91	126.21	126.51	126.81	127.11	127.41	127.71	128.01	128.31	128.61	128.91	129.21	129.51	129.81	130.11	130.41	130.71	131.01	131.31	131.61	131.91	132.21	132.51	132.81	133.11	133.41	133.71	134.01	134.31	134.61	134.91	135.21	135.51	135.81	136.11	136.41	136.71	137.01	137.31	137.61	137.91	138.21	138.51	138.81	139.11	139.41	139.71	140.01	140.31	140.61	140.91	141.21	141.51	141.81	142.11	142.41	142.71	143.01	143.31	143.61	143.91	144.21	144.51	144.81	145.11	145.41	145.71	146.01	146.31	146.61	146.91	147.21	147.51	147.81	148.11	148.41	148.71	149.01	149.31	149.61	149.91	150.21	150.51	150.81	151.11	151.41	151.71	152.01	152.31	152.61	152.91	153.21	153.51	153.81	154.11	154.41	154.71	155.01	155.31	155.61	155.91	156.21	156.51	156.81	157.11	157.41	157.71	158.01	158.31	158.61	158.91	159.21	159.51	159.81	160.11	160.41	160.71	161.01	161.31	161.61	161.91	162.21	162.51	162.81	163.11	163.41	163.71	164.01	164.31	164.61	164.91	165.21	165.51	165.81	166.11	166.41	166.71	167.01	167.31	167.61	167.91	168.21	168.51	168.81	169.11	169.41	169.71	170.01	170.31	170.61	170.91	171.21	171.51	171.81	172.11	172.41	172.71	173.01	173.31	173.61	173.91	174.21	174.51	174.81	175.11	175.41	175.71	176.01	176.31	176.61	176.91	177.21	177.51	177.81	178.11	178.41	178.71	179.01	179.31	179.61	179.91	180.21	180.51	180.81	181.11	181.41	181.71	182.01	182.31	182.61	182.91	183.21	183.51	183.81	184.11	184.41	184.71	185.01	185.31	185.61	185.91	186.21	186.51	186.81	187.11	187.41	187.71	188.01	188.31	188.61	188.91	189.21	189.51	189.81	190.11	190.41	190.71	191.01	191.31	191.61	191.91	192.21	192.51	192.81	193.11	193.41	193.71	194.01	194.31	194.61	194.91	195.21	195.51	195.81	196.11	196.41	196.71	197.01	197.31	197.61	197.91	198.21	198.51	198.81	199.11	199.41	199.71	200.01	200.31	200.61	200.91	201.21	201.51	201.81	202.11	202.41	202.71	203.01	203.31	203.61	203.91	204.21	204.51	204.81	205.11	205.41	205.71	206.01	206.31	206.61	206.91	207.21	207.51	207.81	208.11	208.41	208.71	209.01	209.31	209.61	209.91	210.21	210.51	210.81	211.11	211.41	211.71	212.01	212.31	212.61	212.91	213.21	213.51	213.81	214.11	214.41	214.71	215.01	215.31	215.61	215.91	216.21	216.51	216.81	217.11	217.41	217.71	218.01	218.31	218.61	218.91	219.21	219.51	219.81	220.11	220.41	220.71	221.01	221.31	221.61	221.91	222.21	222.51	222.81	223.11	223.41	223.71	224.01	224.31	224.61	224.91	225.21	225.51	225.81	226.11	226.41	226.71	227.01	227.31	227.61	227.91	228.21	228.51	228.81	229.11	229.41	229.71	230.01	230.31	230.61	230.91	231.21	231.51	231.81	232.11	232.41	232.71	233.01	233.31	233.61	233.91	234.21	234.51	234.81	235.11	235.41	235.71	236.01	236.31	236.61	236.91	237.21	237.51	237.81	238.11	238.41	238.71	239.01	239.31	239.61	239.91	240.21	240.51	240.81	241.11	241.41	241.71	242.01	242.31	242.61	242.91	243.21	243.51	243.81	244.11	244.41	244.71	245.01	245.31	245.61	245.91	246.21	246.51	246.81	247.11	247.41	247.71	248.01	248.31	248.61	248.91	249.21	249.51	249.81	250.11	250.41	250.71	251.01	251.31	251.61	251.91	252.21	252.51	252.81	253.11	253.41	253.71	254.01	254.31	254.61	254.91	255.21	255.51	255.81	256.11	256.41	256.71	257.01	257.31	257.61	257.91	258.21	258.51	258.81	259.11	259.41	259.71	260.01	260.31	260.61	260.91	261.21	261.51	261.81	262.11	262.41	262.71	263.01	263.31	263.61	263.91	264.21	264.51	264.81	265.11	265.41	265.71	266.01	266.31	266.61	266.91	267.21	267.51	267.81	268.11	268.41	268.71	269.01	269.31	269.61	269.91	270.21	270.51	270.81	271.11	271.41	271.71	272.01	272.31	272.61	272.91	273.21	273.51	273.81	274.11	274.41	274.71	275.01	275.31	275.61	275.91	276.21	276.51	276.81	277.11	277.41	277.71	278.01	278.31	278.61	278.91	279.21	279.51	279.81	280.11	280.41	280.71	281.01	281.31	281.61	281.91	282.21	282.51	282.81	283.11	283.41	283.71	284.01	284.31	284.61	284.91	285.21	285.51	285.81	286.11	286.41	286.71	287.01	287.31	287.61	287.91	288.21	288.51	288.81	289.11	289.41	289.71	290.01	290.31	290.61	290.91	291.21	291.51	291.81	292.11	292.41	292.71	293.01	293.31	293.61	293.91	294.21	294.51	294.81	295.11	295.41	295.71	296.01	296.31	296.61	296.91	297.21	297.51	297.81	298.11	298.41	298.71	299.01	299.31	299.61	299.91	300.21	300.51	300.81	301.11	301.41	301.71	302.01	302.31	302.61	302.91	303.21	303.51</

WEIGHTS AND TABLES

WEIGHT OF CIRCULAR BOILER HEADS

Diameter.....	26	28	30	32	34	36	38	40	42	44	46	48	50	54	60	66	70	72	inch.
1/4 inch Thick.....	37	43	50	57	64	72	80	88	98	107	117	127	139	162	199 1/2	241 1/2	271 1/2	287	lbs.
3/8 " " " " " "	47	54	62	71	80	90	100	111	122	134	147	160	173	202	249 1/2	302 1/2	330 1/2	359	"
1/2 " " " " " "	56	65	75	85	96	108	120	133	147	161	176	191	208 1/2	242	299	362 1/2	407 1/2	431	"
5/8 " " " " " "	66 1/2	76	87	98 1/2	112	125 1/2	140	155	171	187	205	223	243	283 1/2	349	422 1/2	475	502 1/2	"
3/4 " " " " " "	75	87	100	113 1/2	128	143 1/2	160	177 1/2	195 1/2	214	234	258	277	323	390	483	543	574 1/2	"

From Steel Plate, 1/4 inch 10.16 lbs., 3/8 inch 12.7 lbs., 1/2 inch 15.24 lbs., 5/8 inch 17.78 lbs., 3/4 inch 20.32 lbs., to the square foot.

GENERAL RULE FOR DETERMINING THE WEIGHT OF ANY PIECE OF WROUGHT IRON

1 Cubic Foot of Wrought Iron.....	480 lbs.	1 Square Inch, 1 foot Long.....	3 1/2 lbs.
1 Square Foot, 1 inch Thick.....	40 " "	1 Square inch, 1 yard Long.....	10 " "

Then to ascertain the weight of any piece of Wrought Iron use the following:

RULE.—Ten times the sectional area in square inches is equal to the weight in lbs. per yard.

WEIGHT OF SHEET IRON PER SQUARE FOOT IN LBS.

U. S. G. Nos.	5	6	7	8	9	10	11	12	13	14	15	16	17	18	19	20	21	22	24	26		
Approximate Decimal.....	.22	.203	.18	.165	.148	.134	.12	.109	.095	.083	.072	.065	.058	.049	.035	.031	.025	.025	.021	.018	.017	.015
Pounds.....	3.77	3.41	3.06	2.71	2.36	2.01	1.66	1.31	1.06	.81	.56	.31	.06	.01	.01	.01	.01	.01	.01	.01	.01	.01

WEIGHT OF SHEET STEEL PER SQUARE FOOT IN LBS.

U. S. Standard Gauge.

U. S. Gauge..... Nos.	10	11	12	13	14	15	16	17	18	19	20	21	22	23	24	25	26	27	28
Approximate Decimal.....	.140	.125	.109	.093	.078	.070	.062	.056	.05	.043	.037	.034	.031	.025	.025	.021	.018	.017	.015
Pounds.....	5.62	5	4.37	3.75	3.12	2.81	2.5	2.25	2	1.75	1.50	1.37	1.25	1.12	1	.875	.75	.687	.625

WEIGHT OF GALVANIZED SHEETS PER SQUARE FOOT IN OUNCES

U. S. Standard Gauge.

U. S. Gauge..... Nos.	15	16	17	18	19	20	21	22	23	24	25	26	27	28	29	30
Ounces.....	47.5	42.5	38.5	34.5	30.5	26.5	24.5	22.5	20.5	18.5	16.5	14.5	13.5	12.5	11.5	10.5

RUSSIA SHEET IRON

Size of Sheets 56 inch x 28 inch.

Russian Gauge..... Nos.	8	9	10	11	12	14
B. W. G. Nos.	25	24	21	23	22	21
Pounds to Sheet.....	8	8 1/2	9	10	11	13

WEIGHT OF SHEET ZINC

Belgian Gauge..... Nos.	6	7	8	9	10	11	12
B. W. G. Nos.	30	29	27	26	25	21	23
Ounces per Square Foot.....	7	8	9	10	11	13	15
Pounds per Sheet, 8 x 3 feet.....	10	11	13	15	17	19	22

WEIGHT OF ONE SQUARE FOOT OF METALS

Thickness Advancing by Sixteenths of an inch.

THICKNESS.	Wrought Iron.	Cast Iron.	Steel.	Copper.	Tin.	Zinc.	Brass.	Gun Metal.	Lead.
	Specific Weight = 1	Specific Weight = .9375	Specific Weight = 1.02	Specific Weight = 1.16	Specific Weight = 1.092	Specific Weight = .910	Specific Weight = 1.052	Specific Weight = 1.052	Specific Weight = 1.48
1/16 inch.....	2.50	2.34	2.55	2.89	2.41	2.28	2.63	2.73	3.71
1/8 " " " " " "	5.00	4.69	5.10	5.79	4.81	4.55	5.26	5.46	7.41
3/16 " " " " " "	7.50	7.03	7.65	8.68	7.22	6.83	7.89	8.19	11.1
1/4 " " " " " "	10.0	9.38	10.2	11.6	9.63	9.10	10.5	10.9	14.8
5/16 " " " " " "	12.5	11.7	12.8	14.5	12.0	11.4	13.2	13.7	18.5
3/8 " " " " " "	15.0	14.1	15.3	17.4	14.4	13.7	15.8	16.4	22.2
7/16 " " " " " "	17.5	16.4	17.9	20.3	16.8	15.9	18.4	19.1	25.9
1/2 " " " " " "	20.0	18.7	20.4	23.2	19.3	18.2	21.1	21.9	29.7
5/8 " " " " " "	22.5	21.1	23.0	26.0	21.7	20.5	23.7	24.6	33.4
3/4 " " " " " "	25.0	23.5	25.5	28.9	24.1	22.8	26.3	27.3	37.1
7/8 " " " " " "	27.5	25.8	28.1	31.8	26.5	25.0	28.9	30.0	40.8
1 foot.....	30.0	28.1	30.6	34.7	28.9	27.3	31.6	32.8	44.5
1 1/16 " " " " " "	32.5	30.5	33.2	37.6	31.3	29.6	34.2	35.9	48.2
1 1/8 " " " " " "	35.0	32.8	35.7	40.5	33.7	31.9	36.8	38.2	51.9
1 1/4 " " " " " "	37.5	35.2	38.3	43.4	36.1	34.1	39.5	41.0	55.6
1 1/2 " " " " " "	40.0	37.5	40.8	46.3	38.5	36.4	42.1	43.7	59.3

NOTES ON STEEL AND IRON

1. The average weight of wrought iron is 480 lbs. per cubic foot. A bar 1 inch square and 3 feet long weighs, therefore, exactly 10 lbs. Hence, To find the sectional area, given the weight per foot :
Multiply by $\frac{3}{10}$
To find the weight per foot, given the sectional area :
Multiply by $\frac{10}{3}$
2. The weight of steel is 2 per cent. greater than that of wrought iron.
To find the sectional area, given weight per foot :
Divide by 3.4
To find the weight per foot, given sectional area :
Multiply by 3.4
3. The centre load at which a bar of wrought iron 1 inch square and 12 inches centre to centre of points of support will give way is very nearly 1 ton (of 2,240 lbs.) For cast iron this ratio is $\frac{3}{5}$ for tension, but becomes variable for compression.
4. The contraction or expansion of wrought iron under changes of temperature is about $\frac{1}{1000}$ of its length, for a variation of 15° Fahrenheit.
The stress thus induced, if the ends are held rigidly fixed, will be about 1 ton (of 2,240 lbs.) per square inch of cross section.
5. The coefficient of expansion of wrought iron for 100° Fahrenheit is 0.00086. Therefore, for a variation in temperature of 125°, a bar of wrought iron 100 feet long will expand or contract 1.025 inches. Conversely, a change in length of 1 inch per 100 feet would be produced by a variation in temperature of 121.5° Fahrenheit.
6. The melting point of iron and steel is about as follows :
Wrought Iron 3000° Fahrenheit.
Cast Iron 2000° " "
Steel 2400° " "
7. The welding heat of wrought iron is 2733° Fahrenheit.

TO TEST STEEL AND IRON

Nitric acid will produce a black spot on steel; the darker the spot the harder the steel. Iron, on the contrary, remains bright if touched with nitric acid.
Good steel in its soft state has a curved fracture and a uniform grey lustre; in its hard state a dull, silvery, uniform white. Cracks, threads, or sparkling particles denote bad quality. Good steel will not bear a white heat without falling to pieces, and will crumble under the hammer at a bright red heat, while at a medium heat it may be drawn to a fine point.

TO FIND THE NUMBER OF SQUARE FEET IN A CIRCLE

Square the diameter and multiply by decimal .7854.

TO RESTORE BURNT STEEL AND WELD IT

Four lbs. white sand, pulverized fine, $\frac{1}{2}$ lb. salamoniac, $\frac{1}{2}$ lb. copperas, $\frac{1}{2}$ lb. rosin, all pulverized and finely mixed, then used as borax.

RECEIPT FOR WELDING STEEL AND IRON

Eight lbs. of sand, 4 oz. salt, 2 oz. copperas, $\frac{1}{2}$ oz. salamoniac, pulverize, mix together, and use the same as any loam.

CASE-HARDENING

Horn, hoof, bone-dust, or shreds of leather, heated together with the article to be case-hardened, in an iron box, to a blood-red heat, then immerse the article in cold water. Some engineers cut up the shreds, etc., fine, and mix them with white wine vinegar and salt.

BRICK-WORK AND MASONRY

Stone-work is estimated by the perch of 25 cubic feet. Brick-work is estimated by the thousand, and for various thicknesses of wall runs as follows:

9 inch wall, 1 brick in thickness,	14 bricks per superficial foot.
13 " " 1 $\frac{1}{2}$ " " "	21 " " "
18 " " 2 " " "	28 " " "
22 " " 2 $\frac{1}{2}$ " " "	35 " " "

WEIGHT OF SKYLIGHT AND FLOOR GLASS PER SQUARE FOOT

Thickness in inches	1 $\frac{1}{8}$	$\frac{3}{8}$	$\frac{1}{2}$	$\frac{3}{4}$	1	1 $\frac{1}{2}$	2
Weight in pounds	1.75	2.62	3.50	5.35	7.00	8.75	14.00

CAPACITY OF CYLINDRICAL CISTERNS

For each Foot of Depth.

Diameter	2	3	4	5	6	7	8	9	10	12	14	15	20	30	feet.
Capacity	21.5	52.9	94.0	146.9	211.5	287.9	376.0	475.9	587.5	846.0	1151.5	1321.9	2350.1	5287.7	gallons.
Weight	196	441	784	1225	1764	2401	3135	3908	4800	7054	9002	11023	19500	44003	pounds.

Ounces
Length
No. in a
N
plate fo

Length
Wire...
Cut AP

Diamete

Len

1
1 $\frac{1}{2}$
2
2 $\frac{1}{2}$
3
3 $\frac{1}{2}$
4
4 $\frac{1}{2}$
5
5 $\frac{1}{2}$
6
6 $\frac{1}{2}$
7
7 $\frac{1}{2}$
8
8 $\frac{1}{2}$
9
10
11
12

Length,
Inches.

1
1 $\frac{1}{2}$
2
2 $\frac{1}{2}$
3
3 $\frac{1}{2}$
4
4 $\frac{1}{2}$
5
5 $\frac{1}{2}$
6
6 $\frac{1}{2}$
7
7 $\frac{1}{2}$
8
8 $\frac{1}{2}$
9
10
11
12

WEIGHTS AND TABLES

LENGTH AND WEIGHT OF BBB IRON TACKS

Ounces.....	1	1½	2	2½	3	4	6	8	10	12	14	16	18	20	22	24
Length.....	1	1½	2	2½	3	4	6	8	10	12	14	16	18	20	22	24
No. in a Pound.....	8885	7025	4865	4080	3005	2135	2145	1715	1375	1155	975	815	815	705	685	525

Numbers given are only approximate, does not include any other kind, and made from standard gauge of plate for each respective size.

AVERAGE NUMBER OF WIRE AND CUT NAILS IN A POUND

Length.....	1	1¼	1½	1¾	2	2¼	2½	2¾	3	3½	4	5	6
Wire.....	870	508	357	285	201	134	112	90	60	43	31	18	11 in lb.
Cut AP.....	850	530	350	230	180	110	100	80	65	40	31	18	12 "

APPROXIMATE WEIGHT OF 100 MACHINE BOLTS

In Pounds, with Square Heads and Nuts, Length Under Head.

Diameter.....	¼	⅜	½	⅝	¾	7/8	1	1¼	1½	1¾	2
Length, Inches.	Lbs.	Lbs.	Lbs.	Lbs.	Lbs.	Lbs.	Lbs.	Lbs.	Lbs.	Lbs.	Lbs.
1.....	8.25	6.13	8.75	12.88	18.75
1½.....	3.50	6.50	6.53	13.91	20.00
1¾.....	3.88	7.00	10.31	14.94	21.37	20.50	38.50
2.....	4.19	7.50	11.00	15.97	22.08	30.50	40.57
2½.....	4.50	8.00	11.88	17.00	24.00	31.50	42.05	65.50	108.00
3.....	4.88	8.50	12.16	18.00	25.31	33.29	44.55	68.81	112.25
3½.....	5.13	9.00	13.14	19.12	26.62	35.08	46.45	72.12	116.50	175.00
4.....	5.44	9.50	14.22	20.18	27.93	36.87	48.35	75.43	121.75	180.00
4½.....	5.75	10.00	15.00	21.25	29.25	38.07	50.25	78.75	126.00	185.00
5.....	6.00	10.50	15.07	22.31	30.56	40.16	52.84	82.00	130.13	190.50
5½.....	6.38	11.00	16.34	23.37	31.87	42.25	55.43	85.37	134.25	196.00
6.....	6.70	11.50	17.01	24.43	33.18	44.04	58.03	88.08	138.38	201.50
6½.....	7.02	12.00	17.07	25.50	34.50	45.84	60.63	91.99	142.50	207.00
7.....	7.00	13.00	19.00	27.63	37.13	49.42	61.88	97.90	151.00	218.00
7½.....	8.30	14.00	20.33	29.75	39.75	53.00	69.13	103.90	159.55	229.00
8.....	8.04	15.00	21.00	31.88	42.38	56.58	73.38	109.99	168.00	240.00
8½.....	9.58	16.00	23.00	34.00	45.00	60.17	77.03	116.00	176.00	251.00
9.....	10.22	17.00	24.58	36.13	47.62	63.69	81.88	122.00	185.00	262.00
9½.....	10.86	18.00	26.17	38.25	50.24	67.21	86.13	128.00	193.65	273.00
10.....	11.50	19.00	27.75	40.38	52.86	70.73	90.38	134.00	202.00	284.00
10½.....	12.14	20.00	29.33	42.50	55.48	74.24	94.61	140.00	210.70	295.00
11.....	12.78	22.00	32.50	46.75	60.72	81.26	103.10	152.05	227.75	317.00
11½.....	14.00	24.00	35.66	51.00	66.00	88.28	111.50	164.10	244.80	339.00
12.....	26.00	38.83	55.25	71.75	95.90	120.08	176.15	261.85	360.00
.....	28.00	42.00	59.50	77.50	102.82	128.57	188.20	278.00	382.00

TANK RIVETS

Number to the Pound.

Length, Inches.	⅜		½		⅝		¾	
	in. Diam.		in. Diam.		in. Diam.		in. Diam.	
	F. & R. H.	C.S.K.	F. & R. H.	C.S.K.	F. & R. H.	C.S.K.	F. & R. H.	C.S.K.
1.....	105	205	103
1½.....	152	172	93
1¾.....	140	147	80	108	50	69	31	46
2.....	125	130	75	94	43	60	28	40
2½.....	103	100	64	75	39	51	23	30
3.....	91	101	50	68	35	47	21	31
3½.....	84	93	49	63	32	42	19	28
4.....	77	85	45	56	31	36	18	24
4½.....	43	42	49	27	31	17	22
5.....	69	40	47	25	31	16	21
5½.....	63	37	42	24	29	15	20
6.....	58	35	41	22	27	14	19
6½.....	54	32	39	21	25	13	18
7.....	50	30	35	20	23	12	17
8.....	48	29	33	19	22	11	16

BOILER RIVETS

Number in a Keg of 100 Pounds.

Length, Inches.	½	⅝	¾	1½	¾	¾
	inch.	inch.	inch.	inch.	inch.	inch.
1.....	690	700	500	450
1½.....	875	725	530	415
1¾.....	800	690	490	380	350	228
2.....	790	650	460	370	320	211
2½.....	720	625	425	357	290	180
3.....	710	595	405	340	271	174
3½.....	690	550	390	325	261	169
4.....	665	530	375	312	257	165
4½.....	630	510	360	297	248	156
5.....	590	500	351	280	237	152
5½.....	555	490	347	280	232	149
6.....	525	475	335	260	219	141
6½.....	500	440	312	242	211	133
7.....	490	410	290	224	203	127
7½.....	430	380	267	212	190	115
8.....	410	350	248	201	180	108
9.....	395	335	241	192	162	102
10.....	326	230	184	153	99

BOILER RIVETS, ALL SIZES, IN STOCK AND MADE TO ORDER

SPECIFIC GRAVITIES

THE FOLLOWING IS A TABLE OF SPECIFIC GRAVITIES

(Water=1.)

Acetic Acid.....	1.05	Ether.....	0.710	Oil, olive.....	0.915
Alcohol, absolute.....	0.792	Glass, flint.....	3.08	Oil, palm.....	0.9
Alcohol, proof.....	0.816	Glass, plate.....	2.70	Oil, rapeseed.....	0.911
Aluminium.....	2.67	Gold.....	19.245	Oil, sperm.....	0.88
Antimony.....	0.71	Gun metal.....	8.46	Oil, whale.....	0.923
Ash, wood.....	0.70	Gutta-percha.....	0.98	Phosphor bronze, cast.....	8.60
Asphalt.....	2.5	Gypsum.....	2.28	Pine, white.....	0.50
Bismuth.....	9.00	Hydrochloric Acid.....	1.2	Pitch.....	1.15
Brass, sheet.....	8.44	India-rubber.....	0.93	Platinum.....	21.522
Brass, wire.....	8.54	Iron, wrought.....	7.78	Plumbago.....	2.27
Cement, Portland.....	1.7	Lead.....	11.36	Sand, quartz.....	2.75
Citric Acid.....	1.22	Lime, quick.....	0.81	Sand, river.....	1.88
Clay.....	1.9	Magnesium.....	1.74	Sea-water.....	1.03
Coal, anthracite.....	1.53	Manganese.....	8.00	Silver.....	10.505
Coal, Newcastle.....	1.27	Mercury.....	13.50	Steel.....	8
Coke.....	0.74	Naphtha.....	0.848	Sulphuric acid.....	1.84
Concrete, in cement.....	2.02	Nickel, cast.....	8.28	Tallow.....	0.91
Concrete, ordinary.....	1.9	Nickel, hammered.....	8.07	Tar.....	1.02
Copper, sheet.....	8.78	Oak, English.....	0.85	Tin.....	7.408
Copper, wire.....	8.9	Oil, castor.....	0.900	Tin, cast.....	7.20
Cork.....	0.24	Oil, linseed.....	0.94	Zinc.....	7
Earth.....	from 1.52 to 2.0	Oil, neatsfoot.....	0.914		

RELATIVE WEIGHTS OF METALS

The weight of bar iron being . . . 1.	The weight of cast iron being . . . 1.	The weight of brass being . . . 1.
Cast iron..... = .95	Bar iron..... = 1.07	Bar iron..... = .92
Steel..... = 1.02	Steel..... = 1.08	Cast iron..... = .86
Brass..... = 1.00	Brass..... = 1.16	Steel..... = .93
Copper..... = 1.16	Copper..... = 1.21	Copper..... = 1.05
Lead..... = 1.48	Lead..... = 1.56	Lead..... = 1.35

EXPANSION OF METALS—(Farady)

The Length of the Bar at 32°=1.

METALS.	At 212°	Expan. per deg. Fah.
Brass.....	1.0019062	.0000106
Copper.....	1.001745	.0000097
Cast Iron.....	1.0011112	.0000082
Steel.....	1.0011860	.0000086
Wrought Iron.....	1.0012575	.000007
Tin.....	1.002	.0000111
Zinc.....	1.002942	.0000163

Almost all bodies expand in equal proportion for each degree between freezing and boiling.

To ascertain the expansion of a body, multiply the dimension of a body by the number of degrees of increase of temperature and then by the expansion per degree.

EXAMPLE.—Required the expansion of a steel rail 30 feet long, with an increase of temperature of 100°.

$$30 \times 100 = 3000 \times .0000086 = 0.198 \text{ foot} = \frac{1}{5} \text{ inch.}$$

SHRINKAGE OF CASTINGS

Patternmakers' rules should be

For Cast Iron	For Brass	For Lead	For Tin	For Zinc
$\frac{1}{8}$	$\frac{1}{16}$	$\frac{1}{8}$	$\frac{1}{16}$	$\frac{1}{16}$ ths.

on an inch longer per lineal foot.

TO FIND THE WEIGHT OF CASTING BY THE WEIGHT OF A PINE PATTERN

Multiply the weight of Pattern

For Cast Iron	For Brass	For Lead	For Tin	For Zinc
by 12.	13.	19.	12.2	11.4

REDUCTION FOR ROUND CORE AND CORE PRINTS

RULE.—Multiply the square of the diameter by the length of the core in inches, and the product by 0.017 is the weight of the pine core, to be deducted from the weight of the pattern.

12 inch
3 feet =
5½ yards
40 rods =
8 furlon
= 32
1 yard =

7.92 incl
100 links
80 chain

6 feet = 1

30½ squar
40 square
4 square
10 square
640 acres
102.40
208.71 feet

1 gallon
avoir
1 gallon o
1 bushel
77.627
A heaped

2 pints =
4 quarts
2 gallons
4 pecks
cubic
1 chaldro
1 cord of

TA

½ kilogr
250 gram
½ kilogr
500 gram
½ kilogr
750 gram
1 kilogr

2
3
4
5
6
7
8
9
10
20
30
40
50
60
70
80
90
100

WEIGHTS AND MEASURES

MEASURES OF LENGTH

12 inches = 1 foot.
 3 feet = 1 yard = 36 inches.
 5½ yards = 1 rod = 198 inches = 10½ ft.
 40 rods = 1 furlong = 7,920 inches = 600 ft. = 220 yds.
 8 furlongs = 1 mile = 63,360 inches = 5,280 ft. = 1,760 yds.
 = 320 rods.
 1 yard = .0005682 mile.

GUNTER'S CHAIN

7.92 inches = 1 link.
 100 links = 1 chain = 4 rods = 66 feet.
 80 chains = 1 mile.

ROPES AND CABLES

6 feet = 1 fathom. 120 fathoms = 1 cable's length.

MEASURES OF SURFACE

144 square inches = 1 square foot.
 9 square feet = 1 square yard = 1,296 square inches.
 100 square feet = 1 square (architect's measure).

LAND

30½ square yards = 1 square rod.
 40 square rods = 1 square rood = 1,210 square yards.
 4 square rods = 1 acre = 4,840 square yards.
 10 square chains = 160 square rods.
 640 acres = 1 square mile = 3,007,600 square yds. =
 102,400 square rods = 2,560 square roods.
 298.71 feet square = 1 acre.

MEASURES OF VOLUME

1 gallon liquid measure = 231 cubic inches, contains 8.339
 avoirdupois lbs. of distilled water at 39.8° Fahrenheit.
 1 gallon dry measure = 268.8 cubic inches.
 1 bushel (Winchester) contains 2,150.42 cubic inches or
 77.627 lbs. distilled water at 39.8° Fahrenheit.
 A heaped bushel contains 2,747.715 cubic inches.

DRY

2 pints = 1 quart = 67.2 cub. in.
 4 quarts = 1 gallon = 268.8 cub. in.
 2 gallons = 1 peck = 16 pints = 8 quarts = 537.6 cub. in.
 4 pecks = 1 bushel = 64 pints = 32 quarts = 8 gals. = 2,150.42
 cubic inches.
 1 chaldron = 36 heaped bushels = 57,244 cubic feet.
 1 cord of wood = 128 cubic feet.

TABLE SHOWING THE REDUCTION OF FRENCH INTO ENGLISH WEIGHTS

		cwt.	qrs.	lbs.	oz.	tons.	cwt.	qrs.	lbs.
1 kilogramme or 1000 grammes	}	=	8½	200 kilogrammes	=	3 3 21
250 grammes		=	2¼		300 "	=
1 kilogramme or 1000 grammes	}	=	1 1½	400 "	=	7 3 14
500 grammes		=	1 10½	500 "	=	9 3 10
1 kilogramme or 1000 grammes	}	=	2 3½	600 "	=	11 3 7
750 grammes		=	4 6½	700 "	=	13 3 3
1 kilogramme	}	=	3 9½	800 "	=	15 3
2 "		=	8 12½	900 "	=
3 "	}	=	11	1000 "	=	19 2 21
4 "		=	13 3½	1015 "	=	1 (or 2240 lbs.)
5 "	}	=	15 6½	2000 "	=	1 19	2 15
6 "		=	17 9½	3000 "	=	2 10
7 "	}	=	19 12½	4000 "	=	3 18	2 26
8 "		=	22	5000 "	=	4 18
9 "	}	=	1 16 1	6000 "	=	5 18 12
10 "		=	2 10 2	7000 "	=	6 17
20 "	}	=	3 4 3	8000 "	=	7 17	1 21
30 "		=	4 3 7	9000 "	=	8 17
40 "	}	=	5 6 5	10000 "	=	9 16	
50 "		=	6 4 4			
60 "	}	=	7 7 7				
70 "		=	8 8 8			
80 "	}	=	9 9 9				
90 "		=	10 10 10			
100 "	}	=	11 11 11				
		=	12 12 12			

LIQUID

4 gills = 1 pint.
 2 pints = 1 quart = 8 gills.
 4 quarts = 1 gallon = 32 gills = 8 pints.
 The Imperial gallon = 277.274 cubic inches, and contains
 10 lbs. of distilled water at 62° Fahrenheit = 1.2003
 Standard gallon

FLUID

60 minims = 1 drachm = 57 grains Troy at 30.8° Fahr.
 8 drachms = 1 ounce = 480 minims = .6501 ounce Troy at
 30.8° Fahrenheit.
 16 ounces = 1 pint = 7680 minims = 128 drachms.
 8 pints = 1 gallon = 61,440 minims = 1,024 drachms = 1 8
 ounces.

MEASURES OF WEIGHT

AVOIRDUPOIS

16 drachms = 1 ounce.
 16 ounces = 1 pound = 256 drachms.
 112 pounds = 1 cwt. = 28 672 drachms = 1,792 ounces.
 20 cwt. = 1 ton = 573,440 drachms = 35,840 ounces =
 2,240 pounds.
 1 pound = 14 ounces, 11 pennyweights, 16 grains Troy, or
 7,000 grains.
 1 ounce = 18 pennyweights, 5½ grains Troy, or 437½ grains.

TROY

24 grains = 1 pennyweight.
 20 pennyweights = 1 ounce = 480 grains.
 12 ounces = 1 pound = 5,760 grains = 240 pennyweights.
 1 Troy pound = .822857 pounds Avoirdupois.
 1 Avoirdupois pound = 1.215278 Troy pound.
 175 Troy ounces = 192 ounces Avoirdupois.

APOTHECARIES'

20 grains = 1 scruple.
 3 scruples = 1 drachm = 60 grains.
 8 drachms = 1 ounce = 480 grains = 24 scruples.
 12 ounces = 1 pound = 5,760 grains = 288 scruples = 480
 drachms.
 The pound, ounce and grain are the same as in Troy
 weight.

METRICAL AND ENGLISH MEASURES

1 metre = 39.37 inches.
 1 kilogram = 2.20473 pounds.
 1 litre = 1 cubic decimetre = .008 quart dry measure.
 1 kilogram per square millimetre = 1.422 pounds per
 square inch.
 2,000 pounds per square inch = 1.406 kilograms per square
 millimetre.
 1 degree Fahrenheit = 1.8 degree centigrade.

EQUATION OF PIPES

It is frequently desirable to know what number of one-sized pipes will be equal in capacity to another given pipe for delivery of steam, air or water. At the same velocity of flow two pipes deliver as the squares of their internal diameters, but the same head will not produce the same velocity in pipes of different sizes or lengths, the difference being usually stated to vary as the square root of the fifth power of the diameter. The friction of a fluid within itself is very slight, and therefore the main resistance to flow is the friction upon the sides of the conduit. This extends to a limited distance, and is, of course, greater in proportion to the contents of a small pipe than of a large. It may be approximated in a given pipe by a constant multiplied by the diameter, or the ratio of flow found by dividing some power of the diameter by the diameter increased by a constant. Careful comparison of a large number of experiments, by different investigators, has developed the following as a close approximation to the relative flow in pipes of different sizes under similar conditions

$$W \propto \sqrt{\frac{d^5}{d+3.6}} \text{ or, } \frac{d^5}{\sqrt{d+3.6}}$$

W being the weight of fluid delivered in a given time, and d being the internal diameter in inches.

The diameters of "standard" steam and gas pipe, however, vary from the nominal diameters, and in apply-

ing this rule it is necessary to take the true measurements, which are given in the following table:

TABLE OF STANDARD SIZES, STEAM AND GAS PIPES

Size, inches	Diameter.		Size, inches	Diameter.		Size, inches	Diameter.	
	Internal.	External.		Internal.	External.		Internal.	External.
1/4	27	40	2 1/2	2.40	2.87	9	8.04	9.02
1/2	30	51	3	3.00	3.5	10	10.02	10.75
3/4	49	67	3 1/2	3.54	4	11	11	11.75
1	62	81	4	4.02	4.5	12	12	12.75
1 1/4	82	105	4 1/2	4.50	5	13	13.25	14
1 1/2	1.04	1.31	5	5.01	5.50	14	14.25	15
1 3/4	1.38	1.66	6	6.00	6.12	15	15.43	16
2	1.61	1.90	7	7.02	7.02	16	16.4	17
2 1/2	2.05	2.37	8	7.98	8.02	17	17.32	18

The table below gives the number of pipes of one size required to equal in delivery other larger pipes of same length and under same conditions. The upper portion above the diagonal line of blanks pertains to "standard" steam and gas pipes, while the lower portion is for pipes of the actual internal diameters given. The figures given in the table opposite the intersection of any two sizes is the number of the smaller sized pipes required to equal one of the larger. Thus, it requires 20 standard 2-inch pipes to equal one standard 7-inch pipe.

TABLE OF EQUATION OF PIPES

STANDARD STEAM AND GAS PIPES																								
Dia.	1/2	3/4	1	1 1/2	2	2 1/2	3	4	5	6	7	8	9	10	11	12	13	14	15	16	17	Dia.		
1	2.60	2.27	4.88	15.8	31.7	52.9	90.9	205	377	620	918	1,292	1,707	2,488	3,014	3,780	4,904	5,927	7,821	8,535	9,717	1		
1 1/4	7.55	2.00	2.05	6.07	14.0	23.3	42.5	90.4	166	273	405	560	770	1,000	1,281	1,682	1,912	2,153	2,263	2,704	2,82	1 1/4		
1 1/2	21.2	9.30	3.20	3.45	6.82	11.4	20.0	44.1	81.1	133	198	278	380	530	649	815	1,070	1,231	1,570	1,837	2,062	1 1/2		
2	54.8	21.0	7.25	2.20	4.23	1.87	1.07	3.00	6.47	11.9	19.0	29.0	40.8	53.8	78.5	95.1	119	155	187	231	290	307	2	
2 1/2	102	30.4	13.6	4.23	1.87	1.07	1.83	3.87	7.12	11.7	17.4	24.4	33.4	47.0	56.9	71.5	92.0	112	138	161	184	21	2 1/2	
3	170	65.4	22.6	7.03	3.11	1.66	1.06	2.12	3.89	6.39	9.48	13.3	20.9	23.7	31.2	39.1	50.0	61.1	75.5	88.0	100	3	3	
4	376	144	49.8	15.5	6.87	3.07	2.21	1.81	3.02	4.48	6.30	8.01	12.1	14.7	18.5	23.9	28.9	35.7	41.0	47.4	4	4	4	
5	680	263	90.9	28.3	12.5	6.70	4.03	1.83	1.65	2.44	3.43	4.60	6.00	8.00	10.0	13.0	15.7	19.4	22.6	25.8	5	5	5	
6	1,110	420	148	40.0	20.4	10.9	6.50	2.07	1.48	2.09	2.85	4.02	4.80	6.11	7.91	9.50	11.8	13.8	15.6	18.4	6	6	6	
7	1,707	650	220	70.5	31.2	16.0	10.0	4.54	2.49	1.51	1.41	1.93	2.71	3.28	4.12	5.34	6.45	7.97	9.31	10.6	7	7	7	
8	2,435	896	322	101.44	23.8	14.3	6.48	3.54	2.18	1.43	1.35	1.83	2.33	2.92	3.70	4.57	5.07	6.00	7.52	8	8	8	8	
9	3,335	1,281	410	137.00	32.5	19.5	8.85	4.85	2.98	1.95	1.37	1.41	1.71	2.14	2.77	3.35	4.14	4.83	5.30	10	10	10	10	
10	4,393	1,688	582	181.80	42.9	25.8	11.7	6.40	3.93	2.57	1.80	1.32	1.21	1.52	1.97	2.38	2.94	3.43	3.01	11	11	11	11	
11	5,642	2,168	747	233	103.55	33.1	15.0	8.22	5.05	3.31	2.32	1.70	1.28	1.20	1.63	1.88	2.43	2.83	3.22	11	11	11	11	
12	7,087	2,723	938	293	129.02	41.6	18.8	10.3	6.34	4.15	2.91	2.13	1.01	1.20	1.20	1.57	1.83	2.20	2.58	12	12	12	12	
13	8,637	3,320	1,140	358	158.81	50.7	23.0	12.6	7.75	5.07	3.50	2.60	1.08	1.53	1.22	1.21	1.49	1.74	1.98	13	13	13	13	
14	10,400	4,070	1,403	438	193	103.02	28.2	15.4	9.48	6.21	4.35	3.18	2.41	1.88	1.50	1.22	1.20	1.44	1.64	14	14	14	14	
15	12,324	4,927	1,698	530	234	125.75	34.1	18.7	11.5	7.52	5.27	3.85	2.92	2.27	1.81	1.48	1.21	1.17	1.35	15	15	15	15	
16	14,478	5,758	1,993	610	274	140.88	40.9	21.8	13.4	8.78	6.15	4.51	3.41	2.60	2.12	1.73	1.42	1.18	1.14	16	16	16	16	
17	17,537	6,738	2,322	724	320	171	103.40	25.0	15.7	10.3	7.20	5.27	3.80	3.11	2.47	2.03	1.60	1.37	1.17	17	17	17	17	
18	20,327	7,810	2,691	840	371	198	110.54	29.6	18.0	12.0	8.35	6.11	4.63	3.60	2.87	2.35	1.92	1.59	1.30	18	18	18	18	
20	26,670	10,240	3,532	1,102	487	260	157.70	38.0	23.0	15.6	10.9	8.02	6.07	4.73	3.70	3.08	2.52	2.08	1.78	1.52	20	20	20	20
24	42,624	16,376	5,044	1,701	778	410	230	113.02	1.38	25.0	17.5	12.8	9.70	7.55	6.01	4.92	4.02	3.32	2.84	2.43	24	24	24	24
30	75,453	28,980	9,993	3,117	1,378	735	443	291	110.07	44.2	31.0	22.7	17.2	13.4	10.7	8.72	7.14	5.88	5.03	4.30	30	30	30	30
36	120,100	46,143	15,902	4,661	2,193	1,172	705	319	175	108.70	60.3	36.1	27.3	21.3	16.9	13.9	11.3	9.37	8.01	6.85	36	36	36	36
42	177,724	63,282	21,531	7,341	3,243	1,734	1,044	473	239	159	104.73	53.4	49.5	31.5	25.1	20.5	16.8	13.9	11.9	10.1	42	42	42	42
48	249,351	85,818	33,020	10,301	4,551	2,434	1,405	603	303	223	140	102.75	56.8	44.2	35.2	28.8	23.5	19.4	16.6	14.2	48	48	48	48

ACTUAL INTERNAL DIAMETERS

que measure:
le:

AND GAS

Diameter.	
Inter- nal.	Exter- nal.
8.01	9.02
10.02	10.75
11	11.75
12	12.75
13.25	14
14.25	15
15.43	16
16.4	17
17.32	18

pipes of one
larger pipes of
The upper
s pertains to
the lower por-
ometers given.
e intersection
er sized pipes
it requires 20
d 7-inch pipe.

16	17	Dia.
18.5359	717	1
363,761	4,282	1 1/2
701,837	2,002	2
83	530	2 1/2
31	269	3
88	161	3 1/2
5	88.0	4
7	41.6	4 1/2
1	22.6	5
3	13.8	6
7	9.31	7
7	6.00	8
14	4.83	9
14	3.43	10
43	2.83	11
83	2.26	12
49	1.74	13
24	1.44	14
-	1.17	15
18	-	16
37	1.17	-
50	1.90	1.16
08	1.78	1.52
32	2.84	2.43
88	5.03	4.90
37	8.01	6.85
9	11.9	10.1
4	16.6	14.2
5	16	17

